

## Purdue University Purdue e-Pubs

---

International Compressor Engineering Conference

School of Mechanical Engineering

---

2006

# Ensuring High Reliability of Reciprocating Compressor with Ball Joint

Tsutomu Nozaki  
*Hitachi Ltd.*

Koichi Sekiguchi  
*Hitachi Ltd.*

Shinichi Sato  
*Hitachi Ltd.*

Gen Konno  
*Hitachi Ltd.*

Follow this and additional works at: <https://docs.lib.purdue.edu/icec>

---

Nozaki, Tsutomu; Sekiguchi, Koichi; Sato, Shinichi; and Konno, Gen, "Ensuring High Reliability of Reciprocating Compressor with Ball Joint" (2006). *International Compressor Engineering Conference*. Paper 1817.  
<https://docs.lib.purdue.edu/icec/1817>

This document has been made available through Purdue e-Pubs, a service of the Purdue University Libraries. Please contact [epubs@purdue.edu](mailto:epubs@purdue.edu) for additional information.

Complete proceedings may be acquired in print and on CD-ROM directly from the Ray W. Herrick Laboratories at <https://engineering.purdue.edu/Herrick/Events/orderlit.html>

## Ensuring High Reliability of Reciprocating Compressor with Ball Joint

Tsutomu NOZAKI\*<sup>1</sup>, Koichi SEKIGUCHI<sup>2</sup>, Shinichi SATO<sup>2</sup>, and Gen KONNO<sup>2</sup>

<sup>1</sup> Mechanical Engineering Research Laboratory, Hitachi, Ltd.  
832-2, Horiguchi, Hitachinaka, Ibaraki 312-0034, Japan  
Tel: +81-29-353-3369; Fax: +81-29-353-3869  
E-mail: tsutomu.nozaki.sx@hitachi.com

<sup>2</sup> Refrigeration & Air Conditioning Division, Hitachi Home & Life Solutions, Inc.  
800 Tomita, Ohira, Shimotsuga, Tochigi 329-4493, Japan  
Tel: +81-282-43-1122; Fax: +81-282-43-1153

### ABSTRACT

Some reciprocating compressors have connecting rods with ball joints to join the crankshaft and the piston. The load of the pressurized gas inside the cylinder directly loads the joint of the piston and the connecting rod. For this reason, it needs to be highly reliable, so it needs to be made of hard material, high-precision spherical surfaces, and a complicated assembling line. Accordingly, the present study estimated an easily assembled ball joint, which ensures reliability.

To ensure the reliability of the reciprocating compressor, the ball joint, which connects the piston to the connecting rod, was optimized by life tests. The tests showed that the ball joint needs an oil path, whose edge does not contact the piston. The oil path is set inside the connecting rod and the face of the outer ball. It also shows that the material of the connecting rod must be harder than that of the piston. That is, the fresh oil is always fed to the ball joint, and this ensures the high reliability of the reciprocating compressor.

### 1. INTRODUCTION

In recent years, the amount of electricity consumed by refrigerators has become one of the highest among household appliances in a consumer's home. Consumers are thus demanding refrigerators with higher efficiency to meet energy-saving regulations [1][2][3][4]. Lower noise levels are also being demanded. For these reasons, compressors with higher efficiencies and lower noise levels must be developed.

Many of the compressors for refrigerators are reciprocating compressors, which have connecting rods to convert the motors' rotation into the pistons' liner motion. In addition, they have joints, which connect the piston to the connecting rod, are directly loaded with pressurized refrigerant. This means that the joint must have high reliability, and there are many studies to maintain the reliability [5].

Some of them have ball joints to connect the pistons and connecting rods. The ball joint can rotate in all directions, that is, the joint can accept errors in right angles, i.e. between a cylinder and a main bearing, between a bearing and a rod in the connecting rod, or between a shaft and a crank pin in a crankshaft. Accordingly, the present study suggests a new ball joint, and found a way to maintain high reliability.

### 2. CONSTRUCTION OF A RECIPROCATING COMPRESSOR

Figure 1 is a cross section of the reciprocating compressor used in this study. This compressor has a low-pressure chamber. At the top of the compressor, there is a pressurizing structure (cylinder and piston, among others), and at the bottom, there is a motor and a crankshaft. The pressurizing structure and DC motor are supported by four springs.

The refrigerant passes from a suction pipe (not illustrated) to the cylinder through a silencer. After the pressure of the refrigerant reaches a certain value, the refrigerant passes out of the compressor through the head cover, discharge silencer (not illustrated), and discharge pipe. The piston is connected to the crankshaft with a connecting rod. The joint connecting the piston and the connecting rod is a ball joint. Figure 2 shows the ball joint. An outer ball and an inner ball of the ball joint are cut to the top and bottom faces. These ball shapes make it easy to assemble the ball

joint. After assembling the ball joint, a connecting-rod-holder is fixed inside the piston for the outer ball, [not to offset the inner ball.

Generally, the pressure from the pressurized refrigerant that loads the top of the piston directly loads the joint connecting the piston and the connecting rod. In addition, it is difficult to maintain the reliability of the joint. So, the reliability was examined by FEM analysis and tests using compressors, and then a way to maintain the reliability of the ball joint was devised according to simulation and test results.

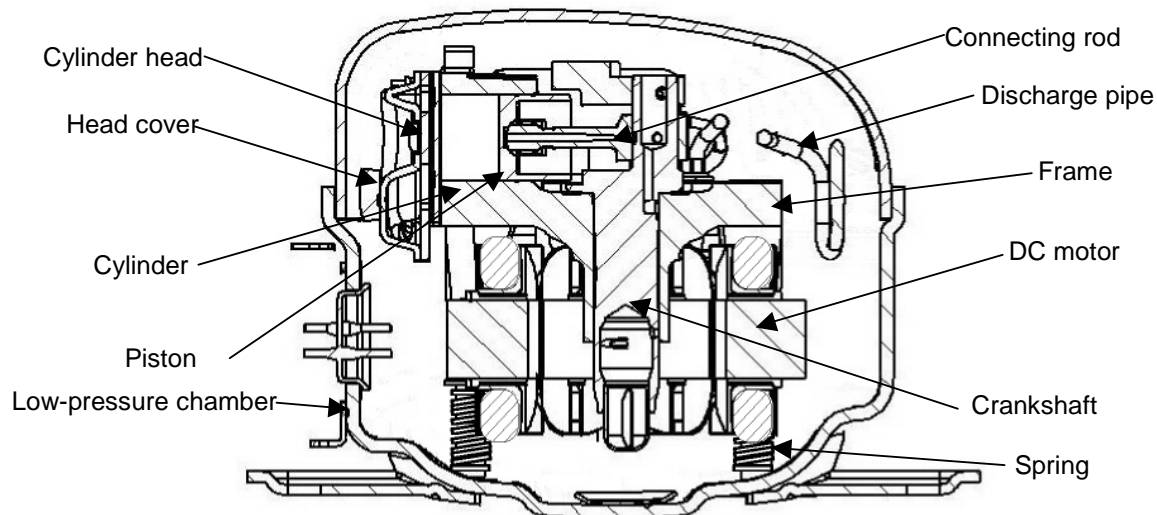

Figure 1: Cross section of reciprocating compressor

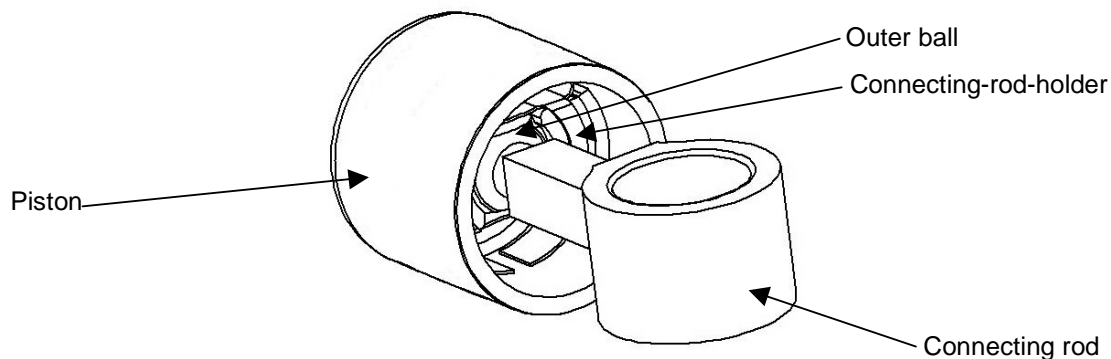

Figure 2: Piston and connecting rod

### 3. METHOD OF RELIABILITY TEST

#### 3.1 Shape of Balls in Ball Joints

Figure 3 is a cross section of the ball joint. The piston and the connecting rod are made of steam-treated iron powder metal. Some connecting rods are nitrified after the steam treatment to examine the combination of the material hardness. Lubricant flows to the lubricant pocket through the lubricant passage. The outer ball of the connecting rod rotates inside the inner ball of the piston. When the surface of the outer ball appears in the lubricant pocket, lubricant clings to the surface of the outer ball and goes through a gap between the outer and inner balls.

Table 1 shows the shape of the outer ball of the connecting rod. Four shapes were tested in this study. Cases A and B are normal spheres. Cases C to E are cut at the top of the connecting rod to avoid the connecting rod's sphere from contacting an edge of the lubricant pocket. In cases B and E, the grooves are carved to discharge lubricant. To examine the materials, cases C and D are the same shape, and made of different materials. Case D is nitrified, but

Case C isn't. In Case C, the piston material is the same as that of the connecting rod, but in case D, the connecting rod is harder than the piston.

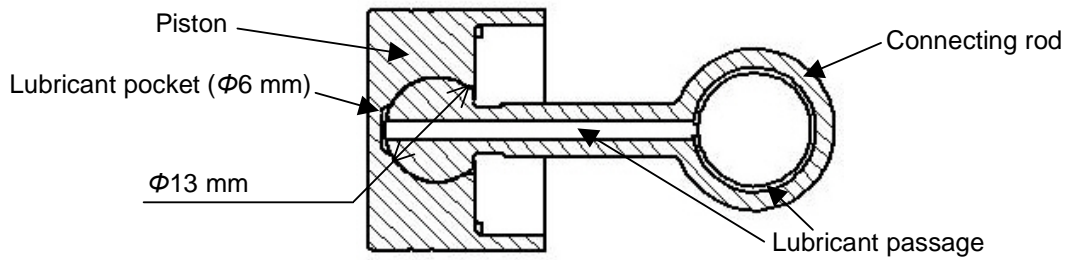
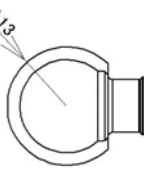
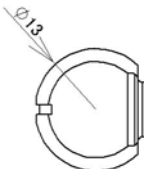
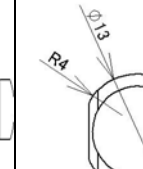
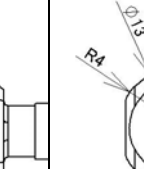
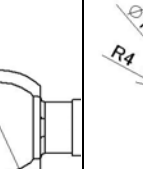

Figure 3: Cross section of ball joint

Table 1: Properties of connecting-rod-outer-balls

	Case A	Case B	Case C	Case D	Case E
Shape	 Φ13 mm sphere	 Φ13 mm sphere with groove	 Φ13 mm sphere with small radius area	 Φ13 mm sphere with small radius area	 Φ13 mm sphere with small radius area and groove
Treatment	Steam treated	Steam treated	Steam treated	Steam treated and nitrified	Steam treated and nitrified

### 3.2 Measuring lubricant flow in ball joint

Lubricant flow around the ball joint is important for maintaining high reliability. However it's difficult to measure the lubricant flow around the ball joint. The ball joint is inside the piston, and it moves inside the cylinder at a high speed. This makes it difficult to measure the lubricant flow around the ball joint. Figure 4 shows a method for measuring the lubricant flow. Before operating the compressor, cotton is set inside the piston to catch the lubricant around the ball joint. After sealing up the cotton with a cap, the compressor is operated for some fixed amount of time. Measuring the weight of the piston before and after operation, and comparing these two weights will show the lubricant flow. The measured cases are Cases A to C and E. These results make it clear that a relationship between the lubricant flow and the shape of the ball joint exists.

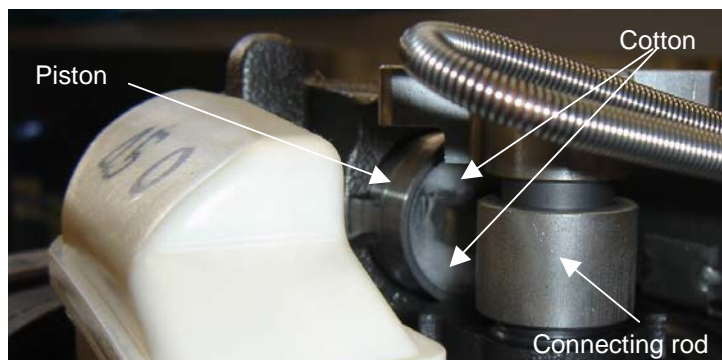

Figure 4: Measuring lubricant flow

**3.3 Measuring Temperatures of Ball Joints**

Measuring the temperatures of the ball joints is difficult in the same way as measuring the lubricant flow. The piston moves so fast that measuring the temperatures with thermocouples is unreliable. The piston movement often breaks the thermocouple.

Measuring temperatures with color-change-crayons doesn't require any cables. The crayon changing color takes place when the temperature of the crayon is higher than it's rating. Figure 5 is an example of measuring the temperature. The crayon is like chalk, and the powder of the crayon is glued on the outer ball of the connecting rod. Figure 5(a) shows the glued crayon powder on the ball joint. After operating the compressor, if the temperature of the ball joint is higher than the temperature of crayon's rating, the crayon powder is melted and changes colors (Figure 5 (b)). The operating conditions for this test are shown as Table 2.

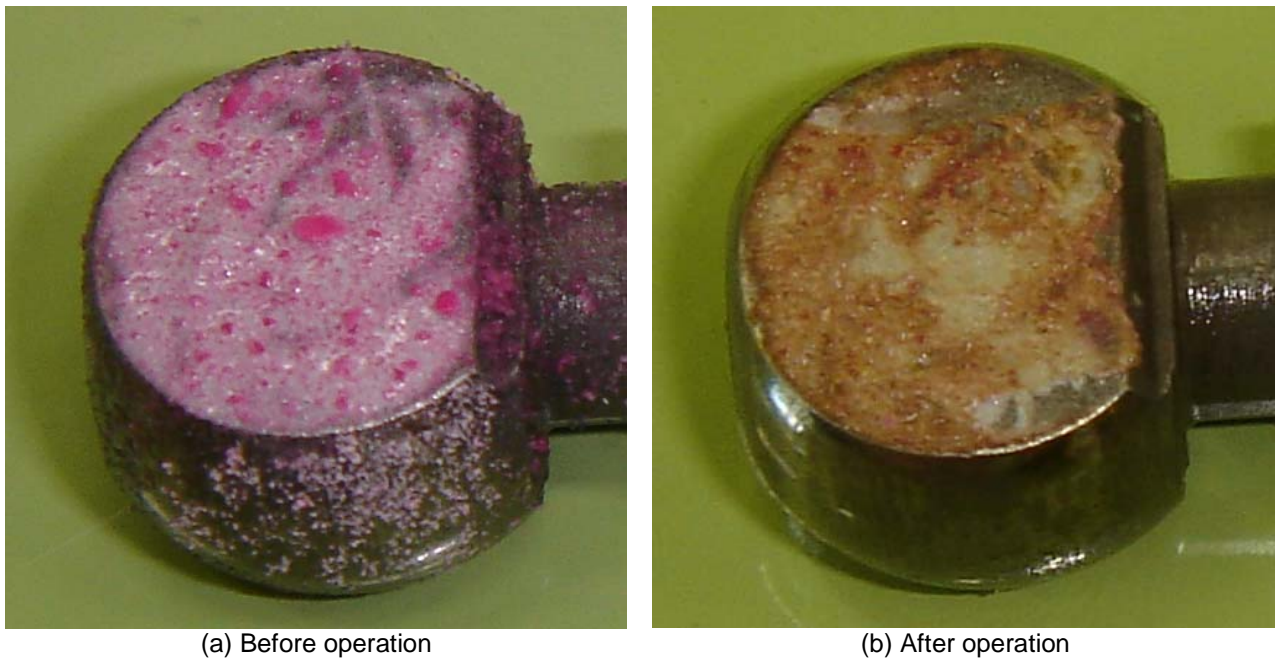

Figure 5: Measuring temperature with THERMO CRAYON

Table 2: Operated condition of measuring ball joint temperatures

	Discharge pressure	Suction pressure	Surrounding temperature
Operational condition	0.902 MPa	0.097 MPa	32 °C

**4. RESULTS AND DISCUSSION**

**4.1 Result of measuring lubricant flow in Ball Joint**

Figure 6 shows the result of measuring the lubricant flow in the ball joint. The horizontal axis shows the narrowest cross section of the lubricant flow area. The left plot is for Case A, the middle is for Case C, and the right is for Case B. The flow area of Case C is larger than that of Case A. This is because of the small radius area of the connecting rod's outer ball. The cut area is crossed to the top and bottom flat faces, and it makes the lubricant flow area. Case B's outer ball is cut groove at the top of the connecting rod, so Case B has the largest lubricant flow area of these three cases.

It is clear from Figure 6 that the lubricant flow is directly proportional to the narrowest cross section of the flow area.

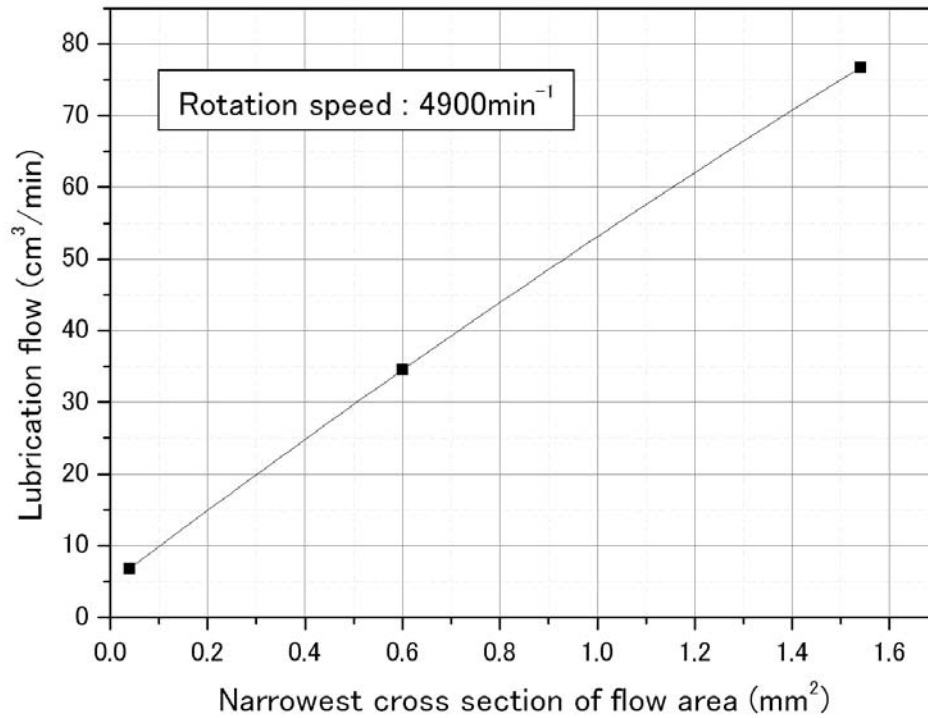

Figure 6: Relationship between lubricant flow and cross section of flow area

**4.2 Result of measuring ball joint temperature**

Table 3 shows the results of measuring the ball joint temperature. The narrowest flow area of each case is written in this table. The temperature for Case A is about 170°C, and it is the highest temperature recorded from the four tested cases. The temperature for Cases B and E, those have the groove at the top of the connecting rod, are about 150°C, and the temperature for Case C is about 160°C.

According to the results in Section 4.1, the larger the lubricant flow area, the more lubricant goes through the ball joint. A large lubricant flow has a large heat capacity, and as a result, it reduces the temperature of the ball joint. High temperature ball joints make lubricant temperatures high, and the load-carrying capacity of the lubricant is decreased. That is, there is a good possibility that the cases with the groove are highly reliable.

Table 3: Result of measuring ball joint temperature

	Case A	Case B	Case C	Case E
Narrowest flow area (mm <sup>2</sup> )	0.04	1.54	0.6	2.14
Temperature of crayon' rating (°C)				
150	Changed	Changed	Changed	Changed
160		Changeless	Changed	Changeless
170	Changed	Changeless	Changeless	
180	Changeless			
190			Changeless	
200	Changeless	Changeless	Changeless	Changeless

### 4.3 Result of accelerated life test

Table 4 shows the results of the accelerated life tests. Two discharge pressures, 0.9 kPa, and 1.7 kPa, are used in these life tests. The discharge pressure is not proportional to the acceleration rate. The higher discharge pressure causes the pressure to overshoot inside the cylinder. That is, the higher the discharge pressure, the larger the accelerating rate and the shorter the testing time becomes.

Comparing Cases A and B, B and C, or D and E, can show a reliability-effect of the connecting rod groove. Case B is more reliable than Case A, and Case E is more reliable than Case D; therefore the connecting rod with a groove is efficient keeping maintaining reliability.

However in the comparison case of B and C, none-groove Case C is more reliable than Case B with a groove. According to the previous section, the lubricant temperature of Case B is 10°C lower than that of Case C, so the cause of this result is another factor. The difference between Case B and C is the shape of the connecting rod. Case B has a non-small radius area, but the top of the Case C connecting rod is cut at a 4mm radius. For Case B, the sharp edges, which are the edge of the groove and the edge of the lubricant pocket, are on the ball face. However, for Case C, there aren't any edges at the ball face. It is clear that an edge-less ball joint is efficient keeping maintaining reliability.

When comparing Cases C and D, Case D is more reliable than Case C. Cases C and D are the same shape, but Case D's connecting rod material is different from that of the piston. For Case C, the connecting rod and the piston are made of the same material. However, for Case D, the connecting rod is nitrified and is harder than the piston. That is, it is clear that the nitrified connecting rod is efficient keeping maintaining reliability.

It is clear from the above results that the groove of the connecting rod and the nitrified connecting rod are efficient in maintaining reliability. In particular, Case E, which has both factors, is the most reliable case of these five cases.

Table 4: Results of accelerated life test

Discharge Pressure (MPa)	Case A	Case B	Case C	Case D	Case E
	None-groove Steam treated	With groove Steam treated	None-groove Steam treated	None-groove Steam treated and nitrified	With groove Steam treated and nitrified
0.9	Abrasion (60 hrs.)	Abrasion (24 days)			
1.7		Abrasion (8~14 hrs.)	Abrasion (48~237 hrs.)	Abrasion (14.2 days)	OK (20 days)

### 4.4 Consideration of maintaining reliability of ball joint

In the previous section, it was shown that there are three factors for maintaining the ball joint reliability. However, it is unknown as to the reason why Case E is the best ball joint of the five cases. So, the contact pressure between the outer and inner balls was simulated by FEA software, ABAQUS/CAE version 6.4. The relationship between the contact pressure and the angle of the breaking sphere (Figure 7) is shown in Figure 8. For Figure 8(a), that calls for Cases A and B, the edge of the lubricant pocket and the edges of the top and bottom flat faces is loaded with a little high contact pressure. However, for (b), that calls for Cases C to E, the contact pressure is higher than for the cases in (a), especially for the intersection points of the two edges, the edge of small radius area and the flat face. This result shows that the edge of the small radius area must be smooth and the edges of top and bottom faces must not be sharp when the top of the outer ball is cut.

Figure 9 shows the high-pressure points for each case. For Figure 9(a), the complete sphere, the points of high contact pressure are always at the edge of the lubricant pocket. This means that the edge cannot resist abrasion if the piston isn't hard enough. For Cases A and B, the piston and connecting rod are made of the same material, and this makes the edge of the lubricant pocket abrasion. For Figure 9(b), the points of high contact pressure are at the edge of the sphere, and the points always move as the connecting rod moves. So, the hard connecting rod can resist abrasion, and it corresponds to the result that Case D is better than Case C.

Figure 10 shows the relationship between the mean contact pressure and the angle of the breaking sphere in connection with the relationship between the contact areas and the angle of the breaking sphere. When the angle of the breaking sphere is 25°, the small radius area is smaller than the area of the lubricant pocket, and the result of 25° angle is the same as the result for Case A (without small radius area). This result shows that decreasing the contact area causes an increase in the mean contact pressure. Generally, the product of the contact area and the mean contact pressure is the pressure load at the top face of the piston. However, in Figure 10, we cannot see that the



slope of the mean contact pressure is larger than that of the contact area. This is caused by the complicated shape, the top and bottom faces, and the small radius area.

It is clear from these simulations and the above results that the hard connecting rod with a small radius area and a small angle of the breaking sphere are important in maintaining the ball joint reliability. On the other hand, from the viewpoint of the groove edge, it should be kept from the inner ball of the piston. So, there is an interrelation between the groove width and the angle of the breaking sphere. Sections 4.1 and 4.2 show that the lubricant flow depends on the narrowest lubricant flow area, and the large cross section of flow area is important for not making the ball joint temperature high. So, the highly reliable ball joint must have a connecting rod with a groove and a permissibly small angle of the breaking sphere.

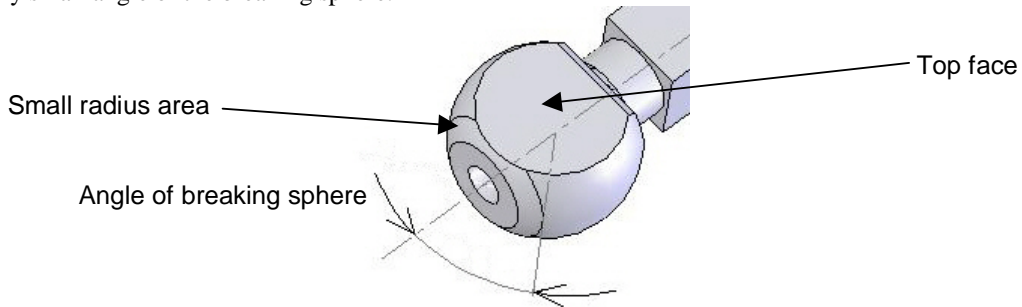

Figure 7: Definition of outer ball's edge angle

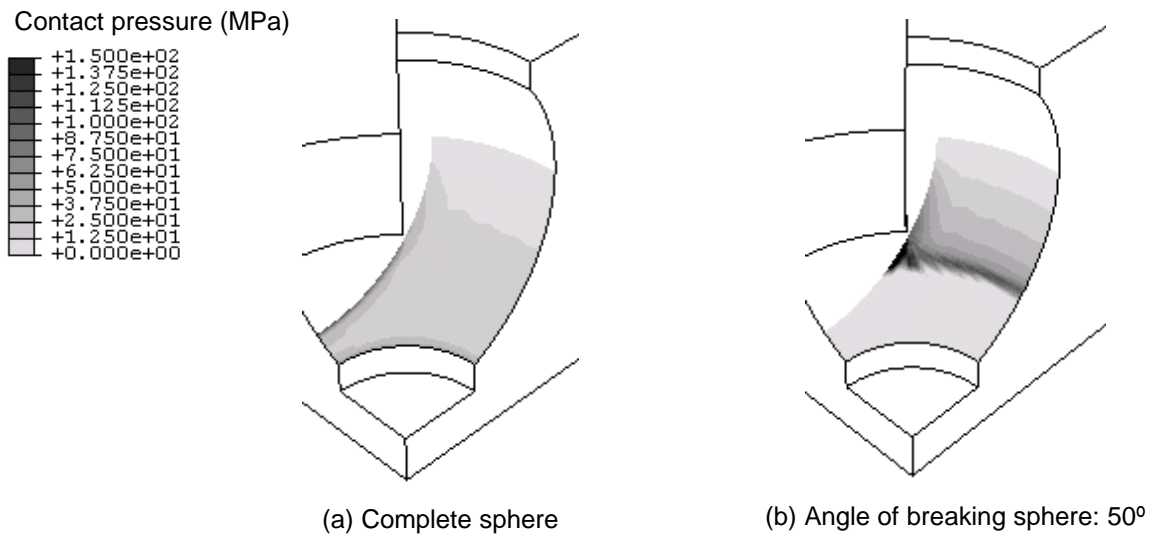

Figure 8: FEA result of piston and connecting rod's outer ball

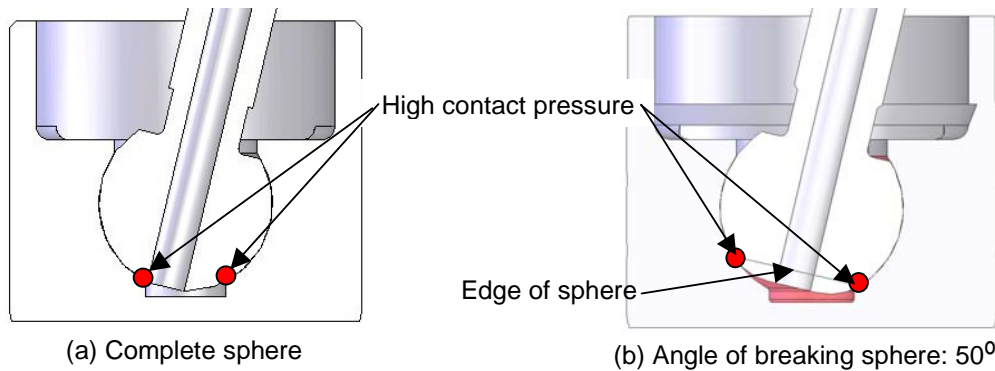

Figure 9: Relationship between lubricant flow and cross section of flow area



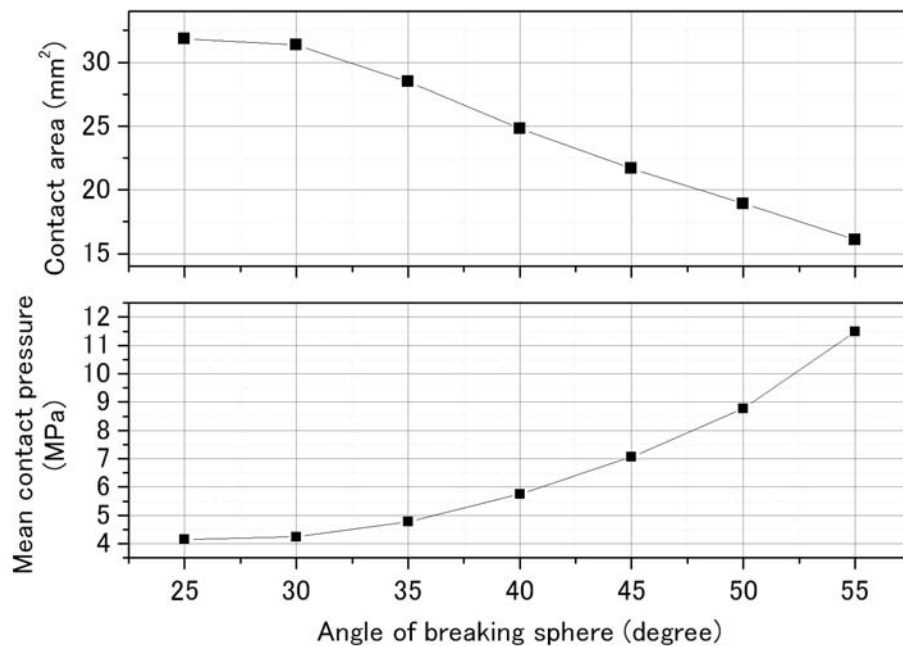

Figure 10: Relationship between contact area, mean contact pressure, and angle of breaking sphere

## 5. CONCLUSIONS

The reliability of the ball joint, which connects the piston to the connecting rod, was optimized by elements tests, life tests, and finite element analysis. The results can be summarized as follows:

- The lubricant flow depends on the cross section of the flow area at the ball joint. Having enough lubricant flowing that is through the groove at the outer ball of the connecting rod keeps the ball joint temperature low and maintains the reliability of the ball joint.
- The smooth small radius area of the outer ball of the connecting rod is needed to part the connecting rod groove edge from the inner ball of the piston, or to part the edge of the lubricant pocket of the piston from the outer ball of the piston. An edge that contacts another ball makes the contact pressure high, and it causes the ball joint to be unreliable.
- The highest contact pressure occurs at the break of the sphere, and it makes the contact pressure of the connecting rod always high. In addition, the nitrified connecting rod, that is harder than the piston, is efficient at maintaining the reliability of the ball joint.

## REFERENCES

- [1] UNEP. Montreal protocol on Substances that Deplete the Ozone Layer. New York: United Nations; 1987
- [2] UNFCCC. Kyoto protocol to the United Nations Frame Convention of Climate Change. New York: United Nations; 1997
- [3] Nozaki, T. and Kato, K., 2002, Evaluation of assembling deformation in reciprocating compressor, Proceedings of 2002 JSRAE Annual Conference: pp. 495-498
- [4] Nozaki, T. and Kato, K., 2003, Evaluation of assembly deformation in a reciprocating compressor, International Conference on Compressors and their Systems: pp. 281-288
- [5] Garland, N. P., and Hadfield, M., 2005, Tribological analysis of hydrocarbon refrigerants applied to the hermetic compressor, Tribology International Vol. 38, No. 4: pp. 732-739