

Purdue University
Purdue e-Pubs

International Compressor Engineering Conference

School of Mechanical Engineering

2006

Magnetizing Method for the Post-Assembly Magnetization of a Hermetic DC Compressor

Chihchung Lo

Industrial Technology Research Institute

Chunchung Yang

Industrial Technology Research Institute

Ann Huang

Industrial Technology Research Institute

Yuchoung Chang

Industrial Technology Research Institute

Follow this and additional works at: <https://docs.lib.purdue.edu/icec>

Lo, Chihchung; Yang, Chunchung; Huang, Ann; and Chang, Yuchoung, "Magnetizing Method for the Post-Assembly Magnetization of a Hermetic DC Compressor" (2006). *International Compressor Engineering Conference*. Paper 1782.
<https://docs.lib.purdue.edu/icec/1782>

This document has been made available through Purdue e-Pubs, a service of the Purdue University Libraries. Please contact epubs@purdue.edu for additional information.

Complete proceedings may be acquired in print and on CD-ROM directly from the Ray W. Herrick Laboratories at <https://engineering.purdue.edu/Herrick/Events/orderlit.html>

Magnetizing Method for the Post-Assembly Magnetization of A Hermetic DC Compressor

Chih-Chung LO*, Chun-Chung YANG, Ann HUANG and Yu-Choung CHANG

Energy & Environment Research Laboratories

Industrial Technology Research Institute

Bldg. 64, 195, Sec. 4, Chung Hsing Rd.

Chutung, Hsinchu, Taiwan, ROC.

Tel: 886-3-5917956, Fax: 886-3-5820250, Email: MarkLo@itri.org.tw

ABSTRACT

A new magnetizing method for the design of post-assembly for a hermetic DC compressor is presented. Assembly of a permanent magnet rotor into the stator core where the permanent magnets have previously been magnetized is a difficult operation. The utility of this approach for the post-assembly magnetization will be demonstrated by a case study, which will use a 4 poles interior permanent magnet motor as a sample of magnetization, and also the predicted performance of the example motor will be validated by experiment.

1. INTRODUCTION

Over the past few years, awareness of environmental problems has grown dramatically worldwide, and tremendous interest has grown in developing the energy conservation technology. The compressor is the device of major power consumption in air-conditioning and refrigeration products. Thus, the manufactures are trying to improve the efficiency of the compressor. As for brushless DC motors are free from exciting loss and rotor copper loss, which is an ideal driving motor to improve the efficiency and has been applied in the compressor gradually (Murakami et al., 1999 and Chen et al., 2004). To distinguish the conventional compressors with induction AC motor, we name the compressors using brushless DC motors as DC compressors.

In a brushless DC motor, permanent is a necessity. Because of perfect magnetic characteristics, rare earth permanent magnet is mainly used. There are some researches on magnetization (Jewell et al., 1993, Zheng et al., 2004 and Zheng et al., 2005). Fig 1 shows the three ways of this step: component magnetization, subassembly magnetization and post-assembly magnetization. And there will be some difficulties when the preceding two ways are used because of the existence of the magnetic forces and ferrous debris during the assembly process.

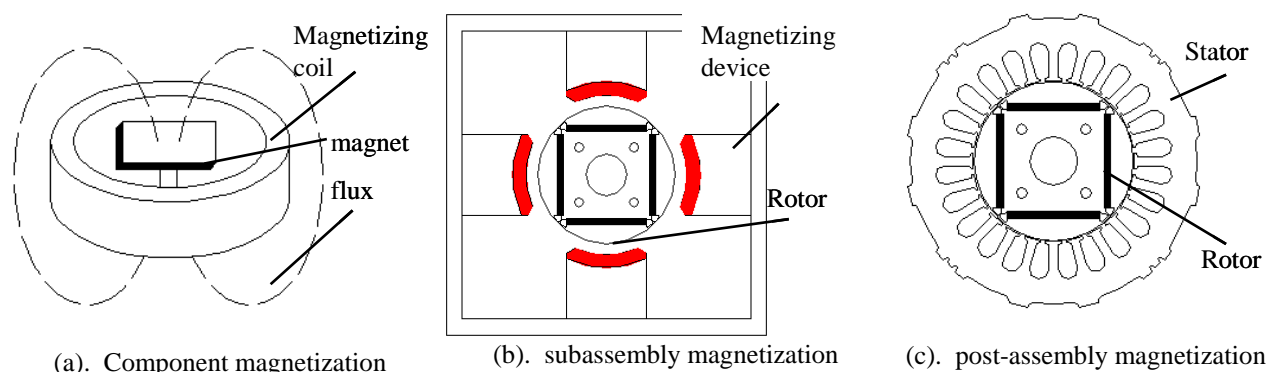

Fig 1. Schematic diagram of component magnetization

Using concentrated-winding as the winding approach for DC brushless motors used for inverted compressors have the advantages of decreasing the motor size and cost, and improving the motor efficiency (Lo et al., 2005). In this study, we will focus on concentrated-winding motor design and analysis.

2. FUNDAMENTAL THEORY MAGNETIZATION

Magnetizing equipment can be classified into two general types: the steady-state and impulse magnetizer. In this study, we applied the capacitor discharge magnetizer. Fig 2 shows the equivalent circuit of the capacitor discharge magnetizer. In a usual arrangement, electric charge is held by a capacitor, and when a silicon controlled rectifier (SCR) is closed on, the electric current is instantaneously flow through the windings, where the magnetizing current instantaneously increases to a peak value.

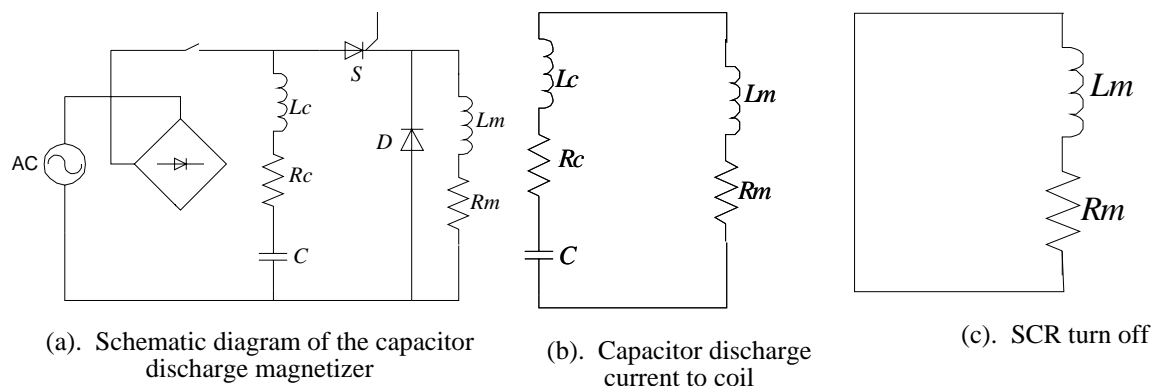

Fig 2. The equivalent circuit of the capacitor discharge magnetizer

The permanent magnet material will be magnetized and got the remanence and coercivity corresponding to the maximum hysteresis loop when an enough big pulse current flows through the coil and makes the magnetic field reach its saturated value (generally 3 to 4 times bigger than the coercivity or 1 to times bigger than the intrinsic one of the permanent) [4-5]. The magneto motive force (MMF) is given by

$$N_c i_c = \sum Hl \quad (1)$$

If magnetization of the permanent magnet material is carried out with a displacement between the magnet axis and the magneto motive force axis, the resultant magnetization is insufficient in quantity, resulting in a reduction of a driving efficiency of a motor and causing an error in detecting a rotational position of a rotor. Thus, the alignment of the magnet axis and the magneto motive force axis is essentially necessary. And, in magnetizing operation, the reluctance torque acts as a rotating force to rotate the rotor, which undesirably causes a shift in position of the rotor to result in insufficient magnetization.

The magnetic reluctance of interior permanent magnet (IPM) motor will be different at rotational position of the rotor. So, the Inductance of IPM motor is function of rotational position of the rotor. In this study, we determined the rotor position by detecting the inductance of motor in magnetizing operation. The paper gives analytical flux distribution to determine the relation between the rotor position and inductance of the motor.

3. FINITE ELEMENT ANALYSIS

In this study, we analyzed and discussed with finite element method (FEM) provided by commercial magnetic field simulation software manufactured by Ansoft Corporation. Fig 3 and fig 4 show the flux distribution at 0 degree position and 45 degree position. The magnetic reluctance is maximum at 45 degree position. So, The inductance of motor is minimum. The stator coils of the motor are connected to supplies an electric current to the stator coils. The magnetizing current supplied to coils of the motor stator is shown in Fig 4.

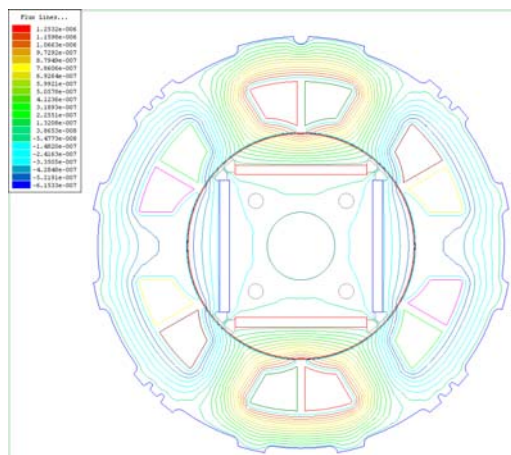

Fig 3. Flux distribution of 0 degree position

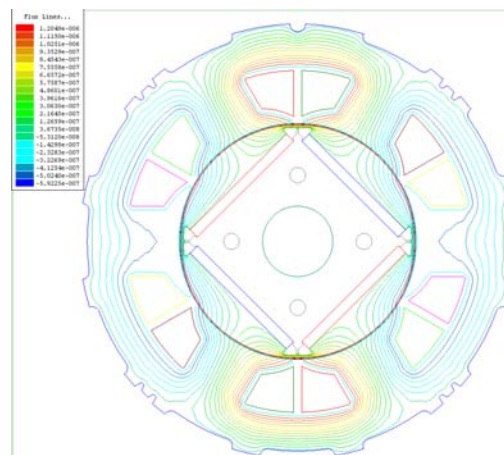

Fig 4. Flux distribution of 45 degree position

When magnetizing, adjusting the relative position of the stator winding and rotor magnetic poles, make sure their axes are overlapped. Fig 5 shows the relation of line inductance and rotor position. The motive device could move the rotor to find minimum inductance. If we find that the inductance of motor is minimum, it fulfils to align the magnet axis with the magneto motive force axis. Then, the magnetizer could supply enough big pulse current to coils of the motor stator to process the magnetization.

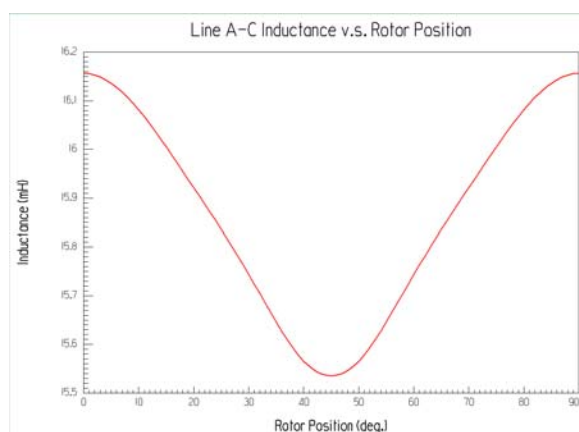

Fig 5. The relation of line inductance and rotor position

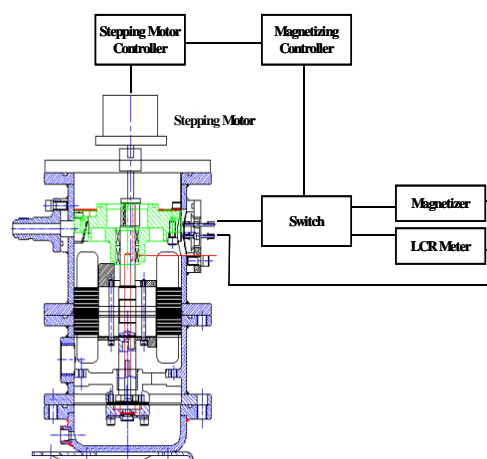

Fig 6. The schematic representation of the apparatus post-assembly magnetization

4. EXPERIMENT AND RESULTS

Fig 6 shows the schematic representation of the apparatus post-assembly magnetization in this study. We measure the inductance by LCR meter to determine the relation of line inductance and rotor position. The magnetizer could supply enough big pulse current to coils of the motor stator.

Three prototype motors, component magnetization, subassembly magnetization and post-assembly magnetization to magnetize the permanent magnets, were manufactured and tested. The flux densities on the rotor surface are measured with tesla meter. Fig 7 and fig 8 show the surface flux density of the rotor and back EMF for different magnetizing method. They can be seen that the surface flux densities and back EMF of three prototype motors, component magnetization, subassembly magnetization and post-assembly magnetization to magnetize the permanent magnets, are consistent.

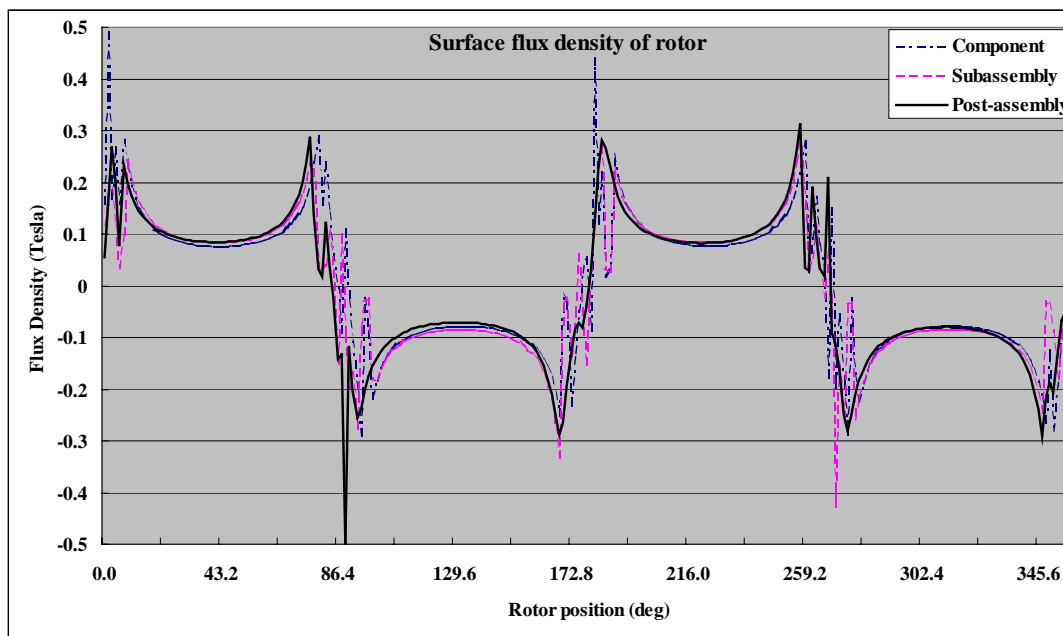

Fig 7. The surface flux density of the rotor for different magnetizing method

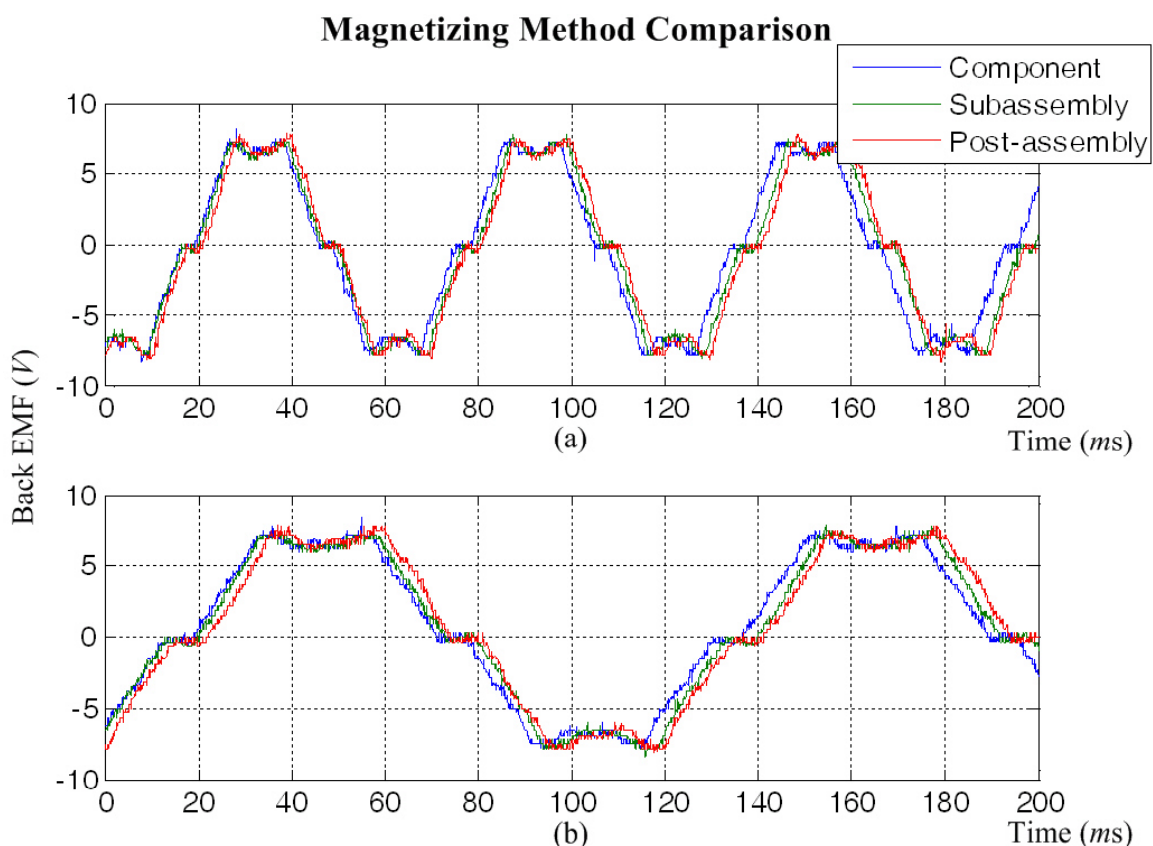

Fig 8. The Back EMF of the rotor for different magnetizing method at different time scale

5. CONCLUSION

For the brushless DC motors used for hermetic DC compressor, we can use component magnetization, subassembly magnetization or post-assembly magnetization to magnetize the permanent magnets. If we provided

with enough magnetizing MMF, the permanent magnets can be fully magnetized among by component magnetization, subassembly magnetization and post-assembly magnetization. The tested motor surface flux density of the component magnetization, subassembly magnetization and post-assembly magnetization are consistent. By contrast, we prefer the post-assembly magnetization in order to avoid the problem of magnetic forces and ferrous debris during the assembly process.

NOMENCLATURE

L_m	Magnetizing coil Inductance [H]	R_m	Magnetizing coil Resistance [Ohm]
L_c	Magnetizer Inductance [H]	R_c	Magnetizer Resistance [Ohm]
C	Magnetizer capacitance [F]	N_c	Magnetizing coil [Turns]
i_c	Magnetizing pulse current [Amps]		
H	Magnetization field strength of each flux path part		
l	The length of each flux path part		

REFERENCES

- H. C. Chen, Y. C. Chang, S. P. Lin, C.M. Huang, Y. C. Chen and K. Y. Liang, 2004, Sensorless Control for DC Inverter-Fed Compressors, *Applied Power Electronics Conference and Exposition, 2004. APEC'04. Nineteenth Annual IEEE*, Vol. 2, p. 1106 - 1110.
- G. W. Jewell and D. Howe, 1993, Impulse Magnetization Strategies for An External Rotor Brushless DC Motor Equipped With a Multipole NdFeB Magnet, 1993, *IEE Colloquium on*, 5 Feb, p. 6/1 -6/4.
- Chih-Chung Lo, Chun-Chung Yang and Hung-Chi Chen, 2005, Anew Motor Design for Hermetic DC Compressor, *IEEE PEDS 2005*, p. 581 – 583.
- H. Murakami, Y. Honda, H. Kiriyama, S. Morimoto and Y. Takeda, 1999, The Performance Comparison of SPMSM, IPMSM and SynRM in Use as Air-conditioning Compressor, in *Proc. IAS'99*, p. 840-845.
- Zheng Ping, Liu Yong, Wang Yan and Cheng Shukang, 2004, Magnetization analysis of the brushless DC motor used for hybrid electric vehicle, *Electromagnetic Launch Technology, 2004 12th Symposium on*, 25-28 May, p. 542 – 545.
- Ping Zheng, Yong Liu, Yan Wang and Shukang Cheng, 2005, Magnetization analysis of the brushless DC motor used for hybrid electric vehicle, *Magnetics, IEEE Transactions on*, Vol. 41, Issue 1, Part 2, Jan. p. 522 – 524.

ACKNOWLEDGMENTS

The authors would like to express gratitude for financial support from the Energy R&D foundation funding provided by the Bureau of Energy, Ministry of Economic Affairs in Taiwan.