

Purdue University
Purdue e-Pubs

International Compressor Engineering Conference

School of Mechanical Engineering

2006

Development of the Compressor for CO₂ Heat Pump with the Single Rotary Mechanism

Hideaki Maeyama

Mitsubishi Electric Corporation

Tetsuhide Yokoyama

Mitsubishi Electric Corporation

Hideto Nakao

Mitsubishi Electric Corporation

Follow this and additional works at: <https://docs.lib.purdue.edu/icec>

Maeyama, Hideaki; Yokoyama, Tetsuhide; and Nakao, Hideto, "Development of the Compressor for CO₂ Heat Pump with the Single Rotary Mechanism" (2006). *International Compressor Engineering Conference*. Paper 1721.
<https://docs.lib.purdue.edu/icec/1721>

This document has been made available through Purdue e-Pubs, a service of the Purdue University Libraries. Please contact epubs@purdue.edu for additional information.

Complete proceedings may be acquired in print and on CD-ROM directly from the Ray W. Herrick Laboratories at <https://engineering.purdue.edu/Herrick/Events/orderlit.html>

DEVELOPMENT OF THE COMPRESSOR FOR CO₂ HEAT PUMP WITH THE SINGLE ROTARY MECHANISM

Hideaki Maeyama^{1*}, Tetsuhide Yokoyama², Hideto Nakao³

¹Mitsubishi Electric Corporation Shizuoka Works
3-18-1, Oshika, Suruga-ku, Shizuoka-City, Japan
Tel: 81-54-287-3112, Fax: 81-54287-3127, Postcode: 422-8528
E-mail: Maeyama.Hideaki@dx.MitsubishiElectric.co.jp

^{2,3}Mitsubishi Electric Corporation Advanced Technology R&D Center
8-1-1, Tsukaguchi-Honmachi, Amagasaki, Hyogo, Japan
²Tel: 81-6-6497-7167, Fax: 81-6-6497-7291, Postcode: 661-8661
E-mail: Yokoyama.Tetsuhide@ak.MitsubishiElectric.co.jp
³Tel: 81-6-6497-7582, Fax: 81-6-6497-7291, Postcode: 661-8661
E-mail: Nakao.Hideto@dr.MitsubishiElectric.co.jp

ABSTRACT

We have developed a new CO₂ heat pump water-heater compressor with a single rotary mechanism. CO₂ refrigerant has different characteristics when compared with refrigerants that we have used before. These characteristics include the operating pressure, the density of the refrigerant, and the speed of sound in the refrigerant. Therefore, during the development of the compressor, there were some issues such as retaining efficiency, oil exhalation amount control, and reliability securing against wear and tear.

To retain efficiency, we minimized the leakage path and optimized the amount of the oil supply to the compression chamber. To control the oil exhalation amount, we enlarged the gas flow path of the motor portion to decrease the speed of the gas flow. To improve reliability, we adopted a coating to the vane surface. Solving issues like these, we were able to commercialize our product.

1. INTRODUCTION

Since the Kyoto protocol was concluded in 1997, the tendency has been to shift to natural refrigerants which don't have issues like the depletion of the ozone layer or global warming. Many natural refrigerants have flammability or toxicity such as Hydrocarbons or Ammonia, and there are many difficulties using them. Among them, in recent years, CO₂ refrigerant is encouraging because it is nonflammable and it has low toxicity. CO₂ refrigerant has a high performance rating in water heating, therefore in Japan, the CO₂ heat pump water-heater was commercialized under the name of "ECO-CUTE". With merits such as conservation of energy, minimal operating cost, and safety, the demand for these systems are increasing by more than 150% per year. Our company started commercial production of the outdoor unit of the CO₂ heat pump water-heater in October 2005. Simultaneously, we developed a CO₂ refrigerant compressor. In this paper, I will describe the development work we did on the single rotary compressor for the CO₂ heat pump water-heater.

2. CHARACTERISTICS OF CO₂ REFRIGERANT

Table.1 shows the characteristics of CO₂ refrigerant and conventional refrigerants. With its environmental characteristics, CO₂ refrigerant is nonflammable and has low toxicity, therefore it can be used safely. However, the operating characteristics have a variety of differences to the other refrigerants. So, to develop a compressor for CO₂ refrigerant, we had to solve issues that were caused by the CO₂ refrigerant's characteristics such as high operating pressure, high density, high speed of sound in the refrigerant gas, and a faster pressure increase due to a high isentropic exponent when it is compressed.

Table.1 The characteristics of CO₂ refrigerant and conventional refrigerants

Refrigerant		HFC	HFC	Natural Refrigerants		
		R22	R410A	Propane	Ammonia	CO ₂
Environmental Characteristics	ODN	0.055	0	0	0	0
	GWP(100years)	1700	1980	3	<1	1
	Toxicity	Low	Low	Low	High	Low
	Flamability	None	None	High	Low	None
Operating *1 Characteristics	Suction Pressure [MPa]	0.58	0.93	0.55	0.52	4.0
	Speed of Sound of suction gas [m/sec]	169	174	205	476	251
	Discharge Pressure [MPa]	2.3	3.5	2.2	2.5	9.5
	Density of discharge gas [kg/m ³]	86	119	47	14	209
	Isentropic Exponent	1.09	1.06	0.99	1.28	1.31

*1
 Evaporating temperature=5
 Superheat of suction gas=5deg
 Discharge pressure is a calculated value when water is heated
 form 17 to 65
 using:
 Ideal opposite flow heat exchanger
 Ideal compressor
 (compressor efficiency=100%)

3. SELECTION OF THE COMPRESSON METHOD

3.1 Selection of Mechanism

When selecting the compression method, at first, we recognized a need for the efficiency due to compression mechanism. To retain the efficiency of the compressor under conditions of CO₂ refrigerant, we had to consider leakage of gas and mechanical loss.

There are two choices to measure against the high differential pressure of CO₂. The first is to stand squarely to the high differential pressure such as a single rotary mechanism. The second is to divide differential pressure into multiple segments, such as a 2-stage rotary and a scroll mechanism. The former needs a drastic improvement of sealing performance at the particular leakage path, but has the advantage of a simple structure and low mechanical loss. The latter doesn't need much segmental sealing performance improvement, but we needed to apply it at multiple leakage points. Moreover it has a complicated structure and high mechanical loss. In total, we think, the efficiency achievement of the former is higher than that of the latter because of the difference of the mechanical loss. Therefore we chose the single rotary mechanism.

Secondly, we had to consider reliability. Each compression method has issues of reliability against the high pressure of CO₂, such as durability around the vane of the rotary mechanism, durability around the swing-guide of the swing rotary mechanism, and the durability of the thrust portion of the scroll mechanism. We could solve them by strengthening the materials of the sliding portion or through structural improvements that reduced pressure loads on the sliding portion. The issues of the rotary mechanism can be solved through these improvements.

3.2 Selection of Shell Type

A previous study of CO₂ refrigerant^[1] showed that if the oil circulation rate in CO₂ refrigerant becomes more than 0.5%, the heat-exchanging ability will be seriously reduced. Therefore, we had to choose a high-pressure shell type that has the oil separating function inside of the enclosure to retain efficiency of the CO₂ refrigeration cycle.

4. STRUCTURE AND THE SPECIFICATION OF THE COMPRESSOR

4.1 Basic Structure

Fig.1 shows the cross section of the single rotary compressor that we have developed. In the basic structure, it is almost the same as a general rotary compressor used in a conventional refrigerant room air conditioner. To adapt it to operate under the high pressure of CO₂ refrigerant, we needed to make some resisting pressure structures in the compressor.

4.1.1 Thick shell and rigid components

To resist the high pressure of CO₂ refrigerant, the compressor enclosure had to be thicker than compressors for conventional refrigerants. We increased the thickness of the compressor shell to more than twice that of a compressor for R410A. The components also need additional resisting pressure structures. For example, we increased the rigidity of the glass-terminal, pipes, and the mechanical components.

4.1.2 Structure avoiding strain

When using a resisting pressure structure, we must consider the strain of the mechanical component caused by the high rigidity of the thick shell. There were a lot of parts that required great accuracy in the compressor. We adopted a “mecha-holder” between the mechanical parts and the thick shell so as not to strain them. The mecha-holder accurately secures mechanical parts indirectly to the thick shell.

4.2 Specification

Table.2 shows the specification of the single rotary compressor for CO₂ refrigerant. It is used in our heat pump water-heater of 4.5kW and 6kW types. The compressor applies a “Joint-lapped” brush-less DC motor^[2] that is used in our compressor installed in the air conditioner of conventional refrigerant.

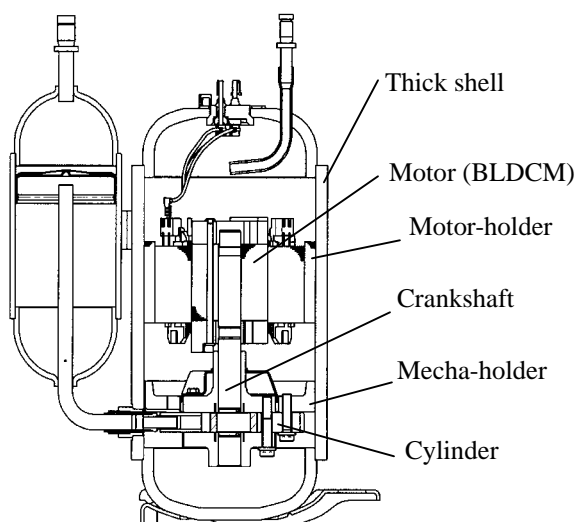

Fig.1 Single Rotary Compressor for CO₂

Table.2 Specification of the CO₂-Single Rotary Compressor

Compressor type	Single Rotary
Displacement	4.5cm ³
Refrigerant	R744 (CO ₂)
Motor	BLDCM (Joint-Lapped Motor)
Usage	HP Water-Heater 4.5kW/6kW

5. IMPROVEMENTS OF THE PERFORMANCE

In adapting CO₂ refrigerant to the rotary compressor, there were some issues in performance caused by the characteristics of CO₂ refrigerant. In this chapter, We'll explain about "Retaining Efficiency", and "Oil Exhalation Amount Control"

5.1 Retaining Efficiency

Among characteristics of CO₂ refrigerant, "high operating pressure", "high speed of sound in the refrigerant gas", "rapid rise in pressure" make it difficult to retain efficiency, because they cause the refrigerant gas to leak relatively easily from the clearance of the mechanism.

Fig.2 shows the rotary mechanism of the compressor. The main leakage path is the radial clearance between the inner diameter of the cylinder and the outer diameter of the rolling-piston. To retain efficiency, we had to reduce the leakage along this path. We were able to make two improvements against this issue.

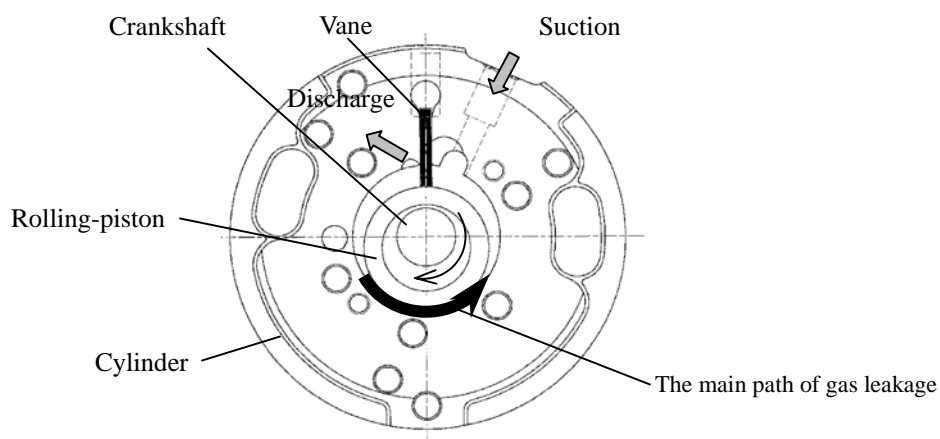

Fig.2 Rotary mechanism

5.1.1 Minimizing the leakage path

To minimize the leakage path, we enlarged the outer diameter of the rolling-piston to that of conventional refrigerants by controlling the accuracy of the parts and the alignment of assembly. Because of the characteristics of CO₂ refrigerant such as a rapid rise in pressure in the compression chamber and the rather low compression ratio, when the crank angle gas pressure reaches to the discharge level considerably earlier than conventional refrigerants. We were able to minimize the radial clearance in a wide range of crank angles using the above method. Fig.3 shows the transition of the radial clearance in a revolution when the compressor is operating under water-heating conditions. From the figure, the mean clearance can be minimized for up to about a half when compared with our compressor for R410A.

5.1.2 Optimizing the amount of the oil supply to improve sealing performance^{[3][4]}

The inside of the rolling-piston has a discharge pressure space. There is also a lot of oil along the oil supply path. We controlled the amount of leaking oil from this space to the compression chamber by optimizing axial direction clearance of the rolling-piston. Fig.4 shows the relation between the axial direction clearance of the rolling-piston and the volumetric efficiency ratio of the compressor. By enlarging the axial direction clearance of the rolling-piston, the oil supply to the compression chamber will increase. Thus improving the sealing performance of the clearance and the volumetric efficiency. But too large a clearance causes an excess of oil and results in a pre-heating of suction gas and an increase in the occupancy of the oil in the compression chamber. So, the volumetric efficiency of the compressor declines. There is an optimized amount of the oil supply to the compression chamber. We chose the optimum oil supply point by controlling the axial direction clearance of the rolling-piston.

5.1.3 Result of improving efficiency

By adopting the measures mentioned above, we improved the efficiency of the compressor. With the compressor, our heat pump water-heater achieved the COP of 4.5 more under the comfortable area condition.

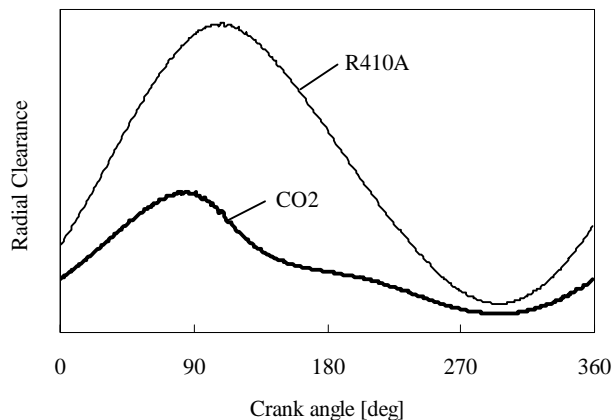

Fig.3 The transition of radial clearance in a revolution (calculated value)

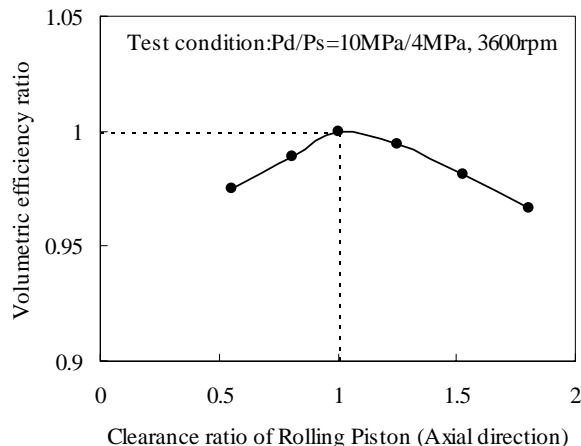

Fig.4 Relation between the axial direction clearance of the rolling-piston and the volumetric efficiency ratio

5.2 Oil Exhalation Amount Control

CO₂ refrigerant gas has a high density and the density difference from the oil is smaller than conventional refrigerants. Therefore, when the refrigerant gas that was compressed in the mechanical section rises up from the underneath of the motor to the upper portion, the oil is easily brought up with the gas. To improve this issue, we added a many-holed “motor-holder” to the outside of the motor. It enlarges the sectional area of the gas flow path of the motor portion, and it decreases the speed of the gas flow. Fig.6 shows the relation between the sectional area of the gas flow path of the motor and the oil circulation rate. Through this measure, we were able to make a sufficient sectional area of the gas flow path of the motor, and were able to reach to 0.1% of oil circulation rate under our standard water-heating condition.

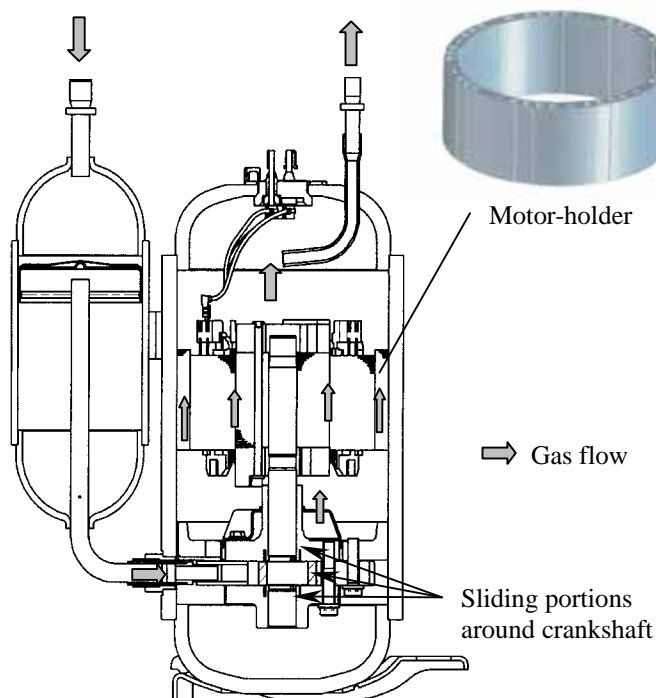

Fig.5 Motor-holder & Sliding parts

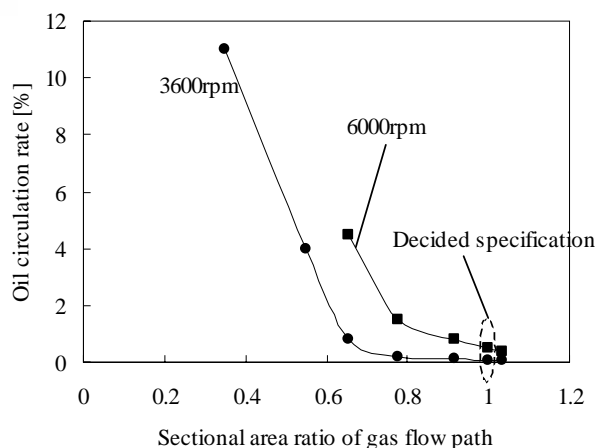

Fig.6 The relation between the sectional area ratio of gas flow path and the oil circulation rate

6. SECURING RELIABILITY

The compressor for CO₂ refrigerant that we newly developed is installed in the heat pump water-heater. A heat pump water-heater needs a longer running duration than a room air conditioner. When there is a high load of long duration on the sliding portion, it is difficult to assure sufficient reliability. Sliding parts in the rotary compressor include the portions around the crankshaft and the portions around the vane.

Sliding portions around the crankshaft are shown in Fig.5, and are under fluid film lubrication. Therefore by utilizing a suitable viscosity of the oil, designing a suitable thickness of the crankshaft, and creating a suitable clearance of the bearing, we can maintain sufficient oil film thickness and secure reliability without much difficulty; even under the heavy load due to high pressure of CO₂ refrigerant.

The sliding parts around the vane are easily conditioned under boundary lubrication. Occasionally, under extreme pressure lubrication, it is very difficult to secure the sliding durability under severe conditions of CO₂ refrigerant. Fig.6 shows loads around the vane. Among the sliding parts around the vane, there can be becomes much severe condition at the suction side of the vane and at the vane tip.

Firstly, to measure the degree of the difficulty, we adapted a vane used in R410A refrigerant whose surface is nitride-processed. We then conducted an examination under CO₂ refrigerant's water-heating conditions. Table.3 shows the result of the examination. We know from the table that the vane used in R410A refrigerant can not resist in the CO₂ refrigerant. Therefore, the compressor for CO₂ refrigerant needs improvement against scratch along the vane side, and needs the improvement against wear at the vane tip.

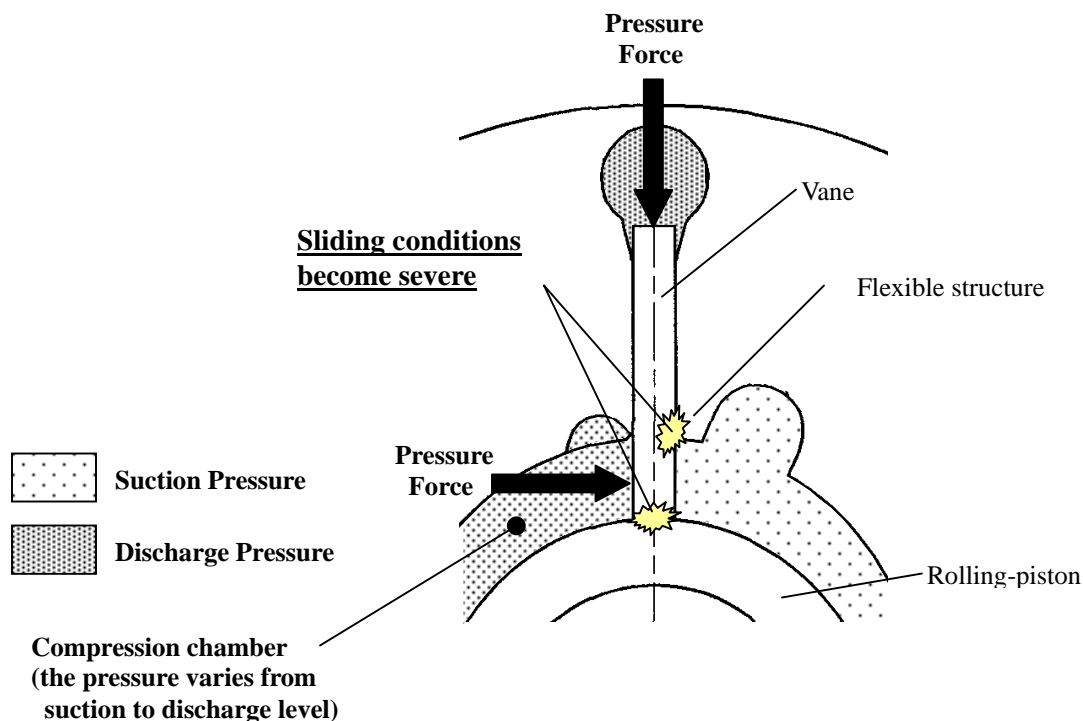

Fig.6 Loads around the vane

Table.3 Result of life test using nitride-processed vane for R-410A in the CO₂ water-heating condition

ITEMS		RESULTS
Sliding parts	Vane side	SCRATCHED in several hours
	Vane slot of cylinder	
	Vane tip	SEVERE WEAR : durability is less than 1/4 of lifetime
	Rolling-piston outer dia.	

6.1 Improvement of Sliding Durability at the Vane Side

When running a rotary compressor, the sliding condition between the cylinder and the vane is severe at the suction and inner side of the vane slot of the cylinder. In order to improve the durability of this section, we added a flexible structure to the cylinder shown as Fig.6. When we added this structure and a large load was applied at the vane slot of the cylinder, the flexible structure bends slightly, and enlarges the contact area of the cylinder and the vane, thus reducing contact pressure. Considering the bend durability of the flexible structure, we applied the structure similar to "Beam of uniform strength" to the flexible structure. Fig.7 shows the relation between the bend stress ratio and the contact pressure ratio of the flexible structure. We controlled them by changing the thickness of the beam. Moreover, we did an FEM-analysis shown as Fig.8, and chose the optimum structure against the contact pressure between the vane and the cylinder, and the bend stress of the beam. We also considered the manufacturing process.

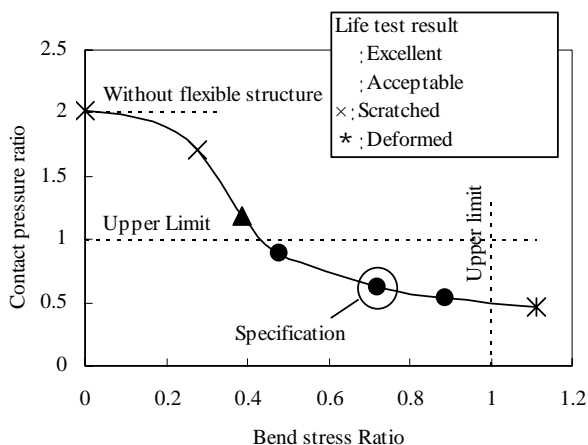

Fig.7 The relation between the bend stress ratio and the contact pressure ratio of the flexible structure

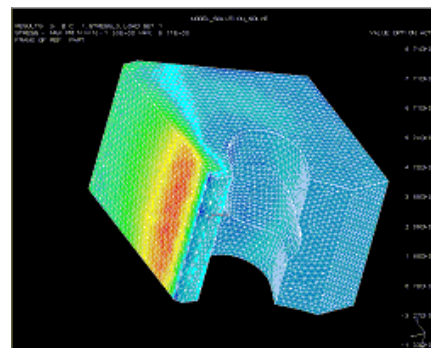

Fig.8 FEM analysis of flexible structure

6.2 Improvement of Sliding Durability at the Vane Tip

Improving durability against sliding at the vane tip was the greatest issue in developing the rotary compressor for CO₂ refrigerant. As mentioned above, we could hardly reach a solution with the diffusion processing such as nitride processing. Therefore we decided to add a coating to the surface of the vane. There are many kinds of coatings, and each coating has its own merits and demerits. We compared various coatings from the viewpoint of "anti-peeling", "reduction of wear of the coating itself on the vane surface", "reduction of wear against the rolling-piston". Table.4 shows the results of the examination. From this result, coatings such as CrN and DLC-Si were considered for using in the single rotary compressor for CO₂ refrigerant. Among them, we chose the DLC-Si coating because it has low friction and the wear of the rolling-piston was minimal. Fig.8 shows the life test results of the coated vane and the nitride-processed vane. The coated vane could function longer than the necessary lifetime established guideline.

Table.4 Results of the examination of various coatings.

Coating	Anti-peeling	Reduction of wear	
		VANE	PISTON
CrN			
DLC	×	-	-
DLC-Si			
WC/C	×	-	-

○ : Excellent
 △ : Acceptable
 × : Poor

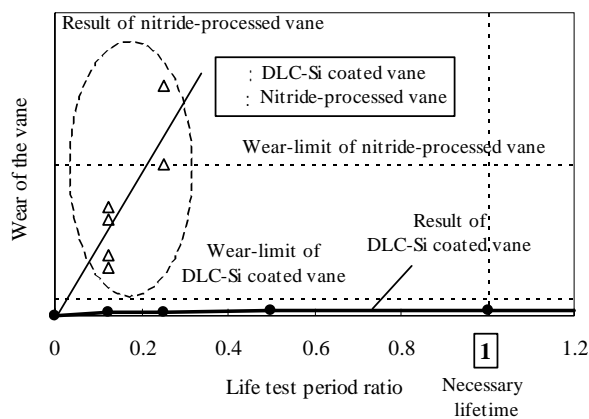

Fig.8 Life test results of the vane

As explained, we applied the DLC-Si coating in the compressor for the first time in the industry. The DLC coating – i.e. “Diamond-Like Carbon” is well known because it is very hard and has a low friction. But DLC also has demerits such as low adhesion strength so it is easy to peel-off. Moreover we could not form a thick coating of film. The DLC-Si coating is the process of forming DLC with Si in it. Adding Si into the DLC improves these issues of the DLC. So the DLC-Si coating has sufficient adhesion strength and sufficient thickness of the film without losing DLC’s merits such as its significant hardness and low friction.

Moreover, by productively minimizing the dispersion of the coating quality, we were able to achieve sufficient durability.

7. CONCLUSION

We were able to establish the specification of the single rotary compressor for CO₂ refrigerant. We were able to solve every issue due to CO₂ refrigerant’s characteristics with this specification.

By minimizing the radial clearance and optimizing the oil supply to the compression chamber, we improved compressor efficiency. With the compressor, our heat pump water-heater achieved the COP of 4.5 more under the comfortable area condition.

By adding a many-holed Motor-holder, we controlled the oil exhalation to 0.1% under our standard water-heating condition.

We established sufficient reliability using the long-duration CO₂ heat pump water-heater by improving the vane side and the vane tip sliding durability.

The single rotary compressor for CO₂ is installed in our heat pump water-heater, and is now in the commercial production.

REFERENCES

- [1] Koyama, S., Ito, D., Lee, S., Kuwahara, and K., Saeki, C., 2005, Experimental Study on Flow Boiling of CO₂-PAG Oil Mixture in Smooth and Micro-fin Tubes, Trans. of the JSRAE, Vol.22, No.4: pp385-393
- [2] Oikawa, T., Tajima, T., Masumoto, K., Akita, H., Kawaguchi, H., Kometani, H., 2002, Development of High Efficiency Brushless DC Motor with New Manufacturing Method of Stator for Compressors, Proceedings of 2002 International Compressor Engineering Conference at Purdue: C12-4
- [3] Yokoyama, T., KODA, T., SEKIYA, S., SASAKI, K., Maeyama, H., 2005, Performance Analysis of Refrigerant Rotary Compressor to Improve Efficiency, Proceedings of the 2005 JSRAE Annual Conference: C304-1
- [4] Hiwata, A., Iida, N., Futagami, Y., Sawai, K., Ishii, N., 2002, Performance Investigation with Oil-injection to Compression Chambers on CO₂-Scroll Compressor, Proceedings of 2002 International Compressor Engineering Conference at Purdue: C18-4