

Purdue University
Purdue e-Pubs

International Compressor Engineering Conference

School of Mechanical Engineering

2002

The Built-In Sensor Bearing to Measure The Shaft Motion Of A Small Rotary Compressor For Air-Conditioning

J. H. Yoon
Carrier Limited Korea

I. S. Hwang
Carrier Limited Korea

H. J. Ahn
University of Virginia

D. C. Han
Seoul National University

Follow this and additional works at: <https://docs.lib.purdue.edu/icec>

Yoon, J. H.; Hwang, I. S.; Ahn, H. J.; and Han, D. C., " The Built-In Sensor Bearing to Measure The Shaft Motion Of A Small Rotary Compressor For Air-Conditioning " (2002). *International Compressor Engineering Conference*. Paper 1515.
<https://docs.lib.purdue.edu/icec/1515>

This document has been made available through Purdue e-Pubs, a service of the Purdue University Libraries. Please contact epubs@purdue.edu for additional information.

Complete proceedings may be acquired in print and on CD-ROM directly from the Ray W. Herrick Laboratories at <https://engineering.purdue.edu/Herrick/Events/orderlit.html>

THE BUILT-IN SENSOR BEARING TO MEASURE THE SHAFT MOTION OF A SMALL ROTARY COMPRESSOR FOR AIR-CONDITIONING

* Jeong-Ho Yoon, In-Su Hwang, Research Engineer, Carrier Ltd., 981-11 Jang Duk-Dong, Gwang San-Ku, Gwang Ju, 506-730 Korea. Tel: +82-62-9580-540 Fax: +82-62-951-9861, E-mail: JeongHo.Yoon@carrier.co.kr; InSu.Hwang@carrier.co.kr *Author for Correspondence

Hyeong-joon Ahn, Research Associate, Dept. of Mech. & Aeros. Eng., University of Virginia, 122 Engineer's way, Charlottesville, Virginia 22904-4746, Tel: 434-924-3498, Fax: 434-982-2246, Email: hja4n@virginia.edu

Dong-chul Han, Professor, School of Mech. & Aeros. Eng., Seoul National University, San 56-1, Shinlim-dong, Kwanak-Ku, Seoul, 151-742 Korea. Tel: +82-2-880-7153, Fax: +82-2-882-3718, E-mail: dchan@amed.snu.ac.kr

ABSTRACT

It is very difficult to measure the shaft motion of the small rotary compressor because of the small space for the sensor mount, high temperature and pressure of compressor, oil mixed with refrigerant, and electromagnetic noise of the motor. This paper detailed the development of a built-in sensor bearing to measure the shaft motion of a rolling piston type compressor for an air conditioner. The built-in sensor bearing is calibrated indirectly through measuring the oil relative permittivity. The shaft motion as well as suction/discharge pressures are measured in both transient and steady state conditions.

NOMENCLATURE

X, Y : Displacement of shaft
 $gain$: Sensor gain

C : Capacitance
 ϵ : Permittivity

INTRODUCTION

In these days, rapid increase of refrigeration and air conditioning system in modern industries bring attention to the urgency of core technology development in this area. The compressor is most important part that determines the entire performance of the refrigeration and air conditioning system. The rotary compressor is most widely used in air conditioning systems for several reasons: continuous and smooth operation, less power consumption as a result of higher efficiency, fewer moving parts leading to greater reliability, lighter weight, more compact size, and quieter operation. However, the usage of alternative refrigerants, and needs for the high efficiency and the long life span make the operating condition of the rotary compressor more severe [1].

Rolling piston type rotary compressors operate on shaft that rotates on an eccentric shaft. Gas enters through a space between the shaft and the cylinder through a suction port. The gas is compressed as the shaft revolves due to the eccentric assembly of the shaft and the cylinder. A discharge port on the opposite side releases the compressed air. High unbalance forces due to both the magnetic pull force by the induction motor and high reaction force from the compressed gas are loaded on the shaft supported by journal bearings. In addition, there were some lubrication problems due to the usage of alternative refrigerants [2] and heat pump application in the winter as well as air conditioner ones in the summer. Therefore, the accurate measurement of the shaft motion in the journal bearing becomes important since it is valuable information to guarantee stable operation of compressor in journal bearings.

It is very difficult to measure the shaft motion of the rotary compressor because of the small space for the sensor mount, high temperature and pressure condition, refrigerant mixed oil, and electromagnetic noise of the motor. There is no literature about the direct measurement of the shaft motion in the journal bearing of a rotary compressor although there was a research on electrical observation of metallic contact between lubrication surfaces [3].

Capacitive sensors are widely used in short-range ultra-precision and control applications because they have higher resolution than other type sensors [4]. Especially, cylindrical capacitive sensor (CCS) had been originally introduced by Chapman [5] for its advantages, which are the insensitivity to geometric errors by the averaging effect and the high resolution with large sensing area. Ahn et al [6] had analyzed the mechanical errors of CCS mathematically, and shown through simulations and experiments that CCS is superior to the probe type sensor in rejecting the geometric errors of a rotor.

This paper detailed the development of a built-in sensor bearing to measure the shaft motion of a rolling piston type compressor for the air conditioner. The built-in sensor bearing is calibrated indirectly through measuring the oil relative permittivity. The shaft motion as well as suction/discharge pressures are measured in various conditions. The experimental results show that the developed built-in sensor bearing can measure the shaft motion not only in steady state but also in transient state.

BUILT-IN SENSOR BEARING

Cylindrical Capacitive Sensor

The greater the ratio of the area of sensor to the distance from the target, the greater the accuracy and resolution of the sensor. In addition, the ratio of sensor area to the characteristic surface finish dimension of the part should be as great as possible to provide the averaging effect [4]. Therefore, the 4-segment CCS is designed to possess the largest sensing area and to use a differential configuration for stability to environmental changes, as shown in Fig. 1 (a). The displacements X , Y of a shaft can be approximated with Eq. (1) of capacities of four sensing electrodes (C_1, C_2, C_3, C_4).

The existing 4-segment CCS is composed of four sensing electrodes, a guarding electrode, and an epoxy resin for insulation, as shown in Fig. 1 (b)

$$\begin{aligned} X &= \text{gain}(C_1 + C_4 - C_2 - C_3), \\ Y &= \text{gain}(C_1 + C_2 - C_3 - C_4) \end{aligned} \quad (1)$$

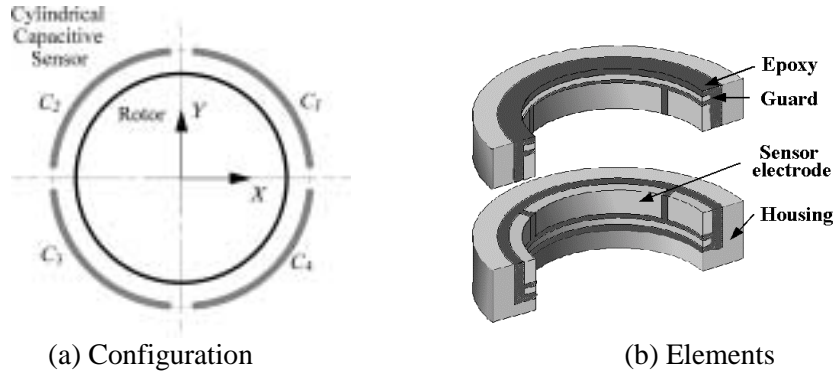

Fig. 1 Cylindrical capacitive sensor

Design of Built-in Sensor Bearing

There are several considerations in the design of the built-in sensor bearing to measure the shaft motion of small rotary compressor for air-conditioning. The built-in sensor bearing is designed based on the CCS that is robust to electro-magnetic noise and has high resolution even with small sensing area.

-The CCS is located in the region of shaft undercut in order to certify the linearity of CCS and to avoid the deformation of the CCS due to the bearing load: The radial clearance of the journal bearing is less than $20 \mu m$ and the orbit radius is less than $10 \mu m$. Since the CCS can guarantee the linearity of sensor within one third of the radial clearance, we need at least the radial clearance of $30 \mu m$ at the location of CCS. There is undercut on the shaft in the middle of the main bearing, which is kind of an oil reservoir for the lubrication. The CCS, jig and bearing are designed to locate the CCS at the location of the undercut of shaft.

-The radial dimension of CCS is designed to account for molding process and wiring: The radial thickness of sensor should be sufficient to endure the cutting force and to minimize the deformation in post-processing.

The radial groove is designed in the outer diameter of the sensor to increase the contact area with the adhesive. In addition, a radial clearance between the sensor and guard is necessary for wiring.

-The angular size and the angular location of sensor segments are determined considering the oil groove of bearing: There is an oil groove inside of journal bearing to provide a sufficient oil supply. Therefore, the CCS is designed so that the oil groove should be passed between sensor segments in order not to injure the sensor segment.

-The some additional shapes of the CCS and the jig should be necessary for the concentric assembly and the insulation among parts after finishing: The shapes of CCS and the jig should be designed to guarantee the concentricity of the CCS and the bearing in assembling parts. In addition, the CCS, jig and bearing should be designed so that each part should be separated and insulated after finishing.

Manufacture of Built-in Sensor Bearing

Roughing of sensor, guard and jig

We make bearing, sensor, guard and jig considering of design consideration, as shown in Fig. 2.

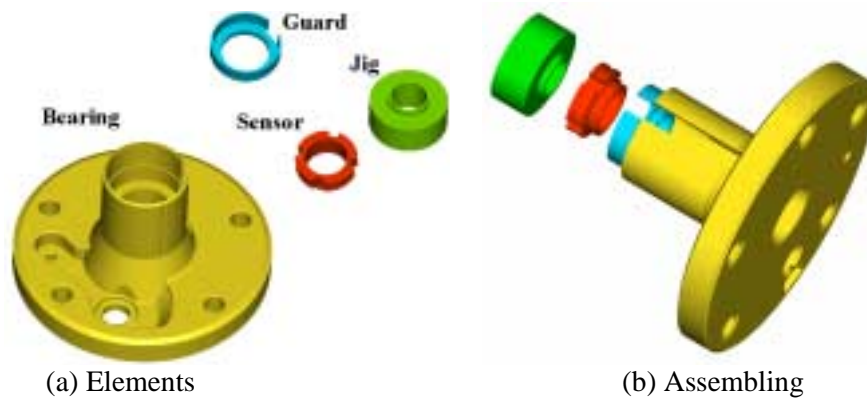

Fig. 2 Bearing sensor, guard and jig

Wiring

The three-coaxial cable for the CCS is made of twisted four Teflon sensor wires, guard shield wire around the sensor wire, and the earthed shield wire around guard wire. The three-coaxial cable is welded to sensor and guard as shown in Fig. 3.

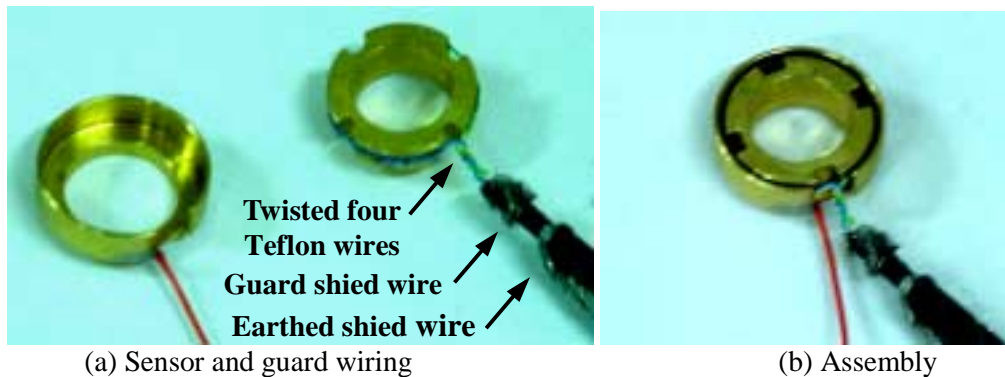

Fig. 3 Wiring of the CCS

Assembling and molding

The three-coaxial cable is welded to CCS. Then, the CCS and jig are molded into the bearing. The CCS is molded into bearing with one-part, heat curing structural adhesive 3M 2214 that provides high-strength bond in high temperature [7]. The characteristics of 3M 2214 are shown in Table. 1.

Table 1 Epoxy adhesive 2214

Recommended heat curing condition			Tensile strength 22.25 (kg/25mm)	Shear strength (kg/cm ² at Temp.)			
Time	Temp.	Pressure		-55°C	24°C	82°C	121°C
60 min.	121°C	0.7kg/cm ²		210	315	315	119

Finishing

The epoxy adhesive in the built-in sensor bearing is cured at high temperature and finished. The finishing built-in sensor bearing is shown in Fig. 4 (a) and the cross section of built-in sensor bearing in Fig. 4 (b). While the sensor, guard and epoxy can be easily found in the cross section of built-in sensor bearing, the jig cannot be distinguished from bearing because the radial clearance between bearing and jig is very small and the material of jig is same as the bearing. Although the wide circumferential gap between sensor segments as shown in Fig. 4 (b) makes resolution of the CCS, these gaps should be so wide that the oil groove can pass through without injuring the sensor segments.



(a) Bearing

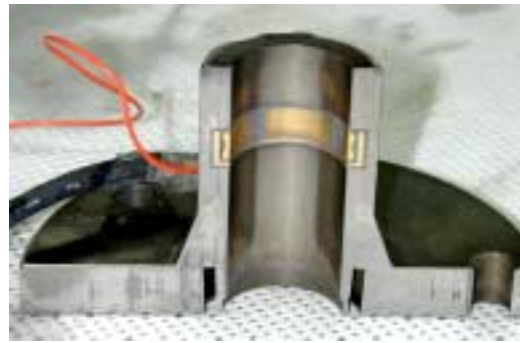

(b) Cross-section

Fig. 4 Built-in sensor bearing after finishing

AMPLIFIER FOR BUILT-IN SENSOR BEARING

The charge transfer method is adopted as a capacitance detecting circuit to avoid interference between the sensor electrodes and to achieve the wide bandwidth. The voltage proportional to unknown capacitance can be obtained with the charge transfer method, which consists of the charge/discharge of unknown capacitance and the integration of the discharged pulse current. Sensor circuit board and sensor amplifier box are shown in Fig. 5.



(a) Circuit board



(b) Amplifier box

Fig.5 Sensor amplifier for detecting capacitance

CALIBRATION OF BUILT-IN SENSOR BEARING

In general, the displacement sensor is calibrated using a X-Y table of the high resolution. However, a X-Y table of sub-micron resolution and accurate adjustment of the squareness are required in this case since the radial clearance between the CCS and the shaft is less than $20 \mu m$ and the orbit radius is about $10 \mu m$. Therefore, it is very difficult to apply general calibration scheme of displacement sensor to built-in sensor bearing.

If the geometric data of the CCS and shaft are exactly known, the simulated and experimental gains of the CCS agree well. Therefore, if the relative permittivity of oil is not changed significantly with the variations of temperature, we calibrate the built-in sensor bearing using the indirect calibration of measuring the relative permittivity of oil. The relative permittivity of oil can be calculated experimentally through the procedure as follows, and Eq. (2). The capacitances of the CCS in four cases are measured: with rotor in the air, without rotor in the air, with rotor in the oil and without rotor in the oil. Substituting the measured capacitances into Eq. (2), the relative permittivity of the oil can be obtained and the resulting relative permittivity is about 1.6.

$$\epsilon_{oil} = \frac{\sum_{n=1}^4 C_n \Big|_{oilrotor} - \sum_{n=1}^4 C_n \Big|_{oilr}}{\sum_{n=1}^4 C_n \Big|_{airrotor} - \sum_{n=1}^4 C_n \Big|_{airr}} \quad (2)$$

The gain of the CCS is simulated within the range of $\pm 10 \mu m$ using the calculated relative permittivity of the oil and geometric data of the built-in sensor bearing and the shaft. The gain of the CCS is about $640 V/mm$ and the CCS has a good linearity in the entire range.

EXPERIMENTS

Experiment Setup

Experiment setups of measuring the shaft motion in both transient and steady states are built to validate the effectiveness of built-in sensor bearing. The average suction/discharge pressure and temperature are controlled and monitored by the enduring tester. Two dynamic pressure sensors for suction and discharge pressures and the built-in sensor bearing for shaft motion are equipped in the bolt shell. The sensors are linked outside of the bolt shell through pressure resistive connector. The measurement data are recorded with digital oscilloscope. The schematic of experimental setup to measure the shaft motion and the suction/discharge pressure is shown in Fig. 6.

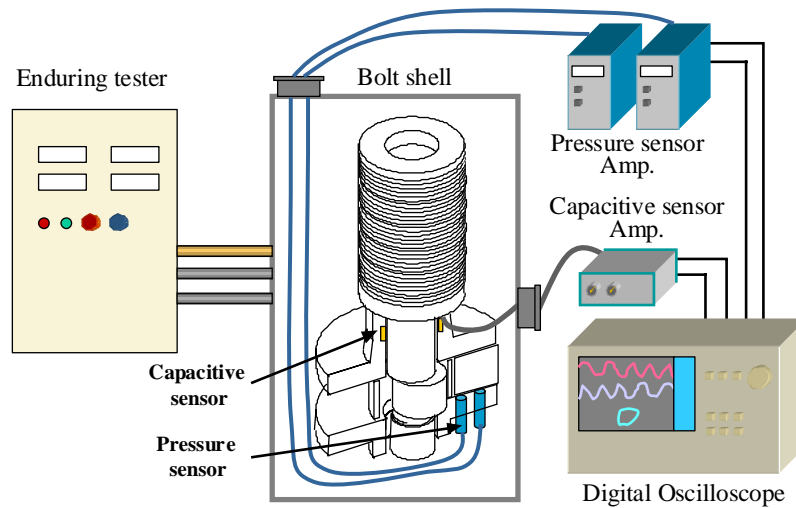

Fig. 6 Schematic of experimental setup

The pressure resistive connector is developed to link the three-coaxial cable of the CCS out of bolt shell without leakage. The schematic of the pressure resistive sensor is shown in Fig. 7 (a) and the photo of assembly in bolt shell in Fig. 7 (b).

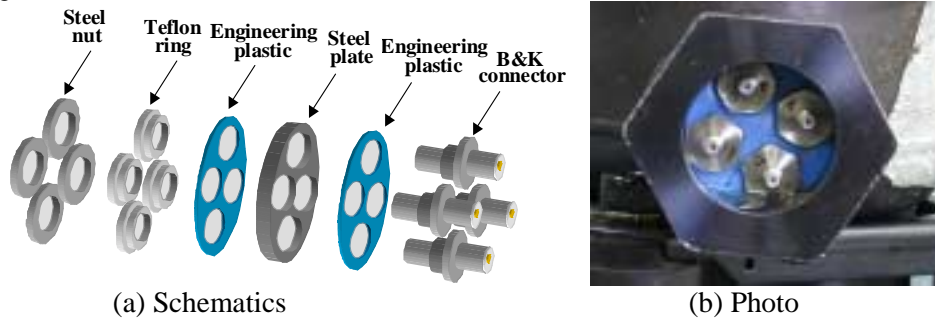

Fig. 7 Pressure resistive connector

Measurement of Transient Response

The condition of 3 minutes on-off

The three minutes on-off states during 30 minutes are shown in Fig. 8. The transient responses of shaft and pressures during on-off states can be detected in this condition. The upper part above zero means suction pressure and the lower one does ten times amplified discharge pressure in the pressure time plot. The shape of pressure in each start is not the same and the pressure is not stabilized yet.

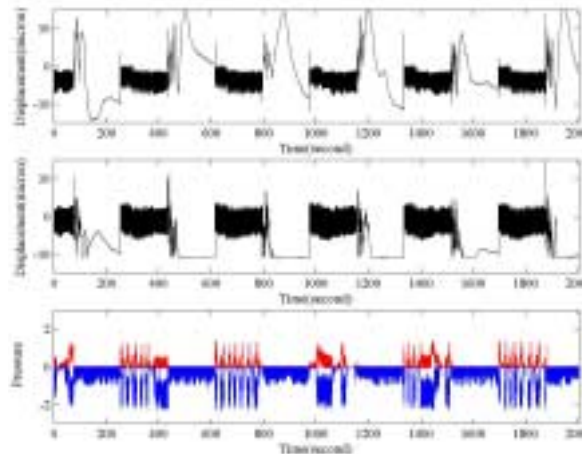

Fig. 8 Transient response of 3 minutes on-off during 30 minutes

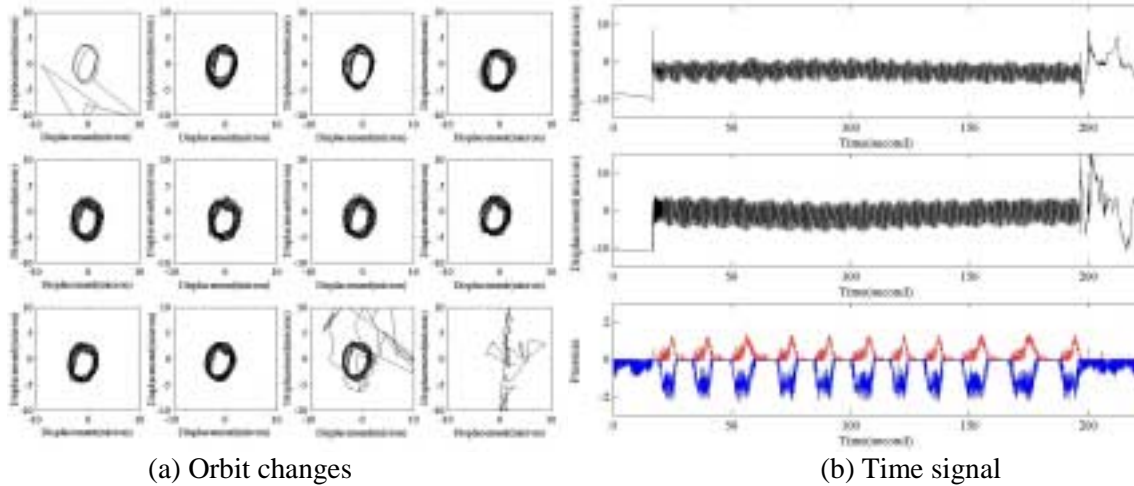

Fig. 9 Transient response during one on-off state

The transient response during one on-off state is zoomed and shown in Fig. 9. The shaft responds sensitively to the variation of the pressures. There seems to be a kind of high frequency noise, which means that there is contact between the shaft and bearing caused by the imperfect construction of oil film in the start-up time. The upper part above zero means suction pressure and the lower part means the ten times amplified discharge pressure in the pressure time plot.

Measurement of Steady State Response

The shaft orbit and suction/discharge pressures are measured in two steady states of maximum delta pressure and maximum pressure ratio. The temperature conditions of two steady states are shown in Table 2. The superheat means that the refrigerant extracts the heat in passing from the accumulator to the compressor. For example, the temperature of refrigerant from the accumulator is 30°F and that of the compressor is 40°F.

Table 2 Two steady-state conditions

	Suction Temperature (°F)	Discharge Temperature (°F)	Suction superheat Temperature (°F)
Maximum delta pressure	30	155	40
Maximum pressure ratio	-15	100	-5

Maximum delta pressure

The shaft orbits are measured several times in maximum delta pressure condition and are shown in Fig. 10 (a). The time responses of shaft and pressures are shown in Fig. 10 (b). The upper part above zero means suction pressure and the lower part means the ten times amplified discharge pressure in the pressure time plot. The discharge pressure from 0.06 to 1.4 second has distinct two peaks in one cycle due to the twice opening of the discharge valve and the shaft responds to the pressure variations directly.

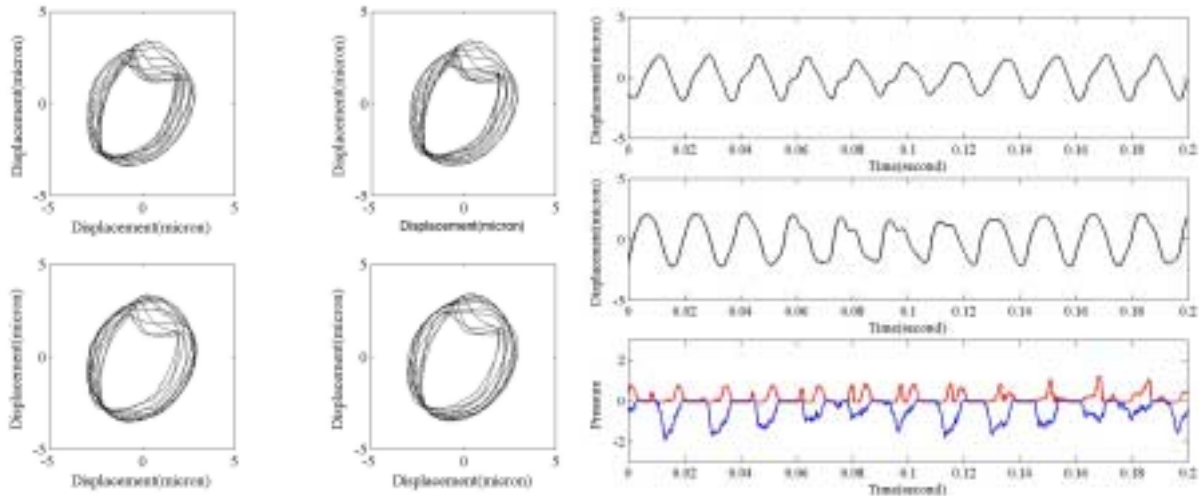

(a) Shaft orbit (b) Time signal
 Fig. 10 Steady state responses in maximum delta pressure condition

Maximum pressure ratio

The shaft orbits are measured several times for the maximum pressure ratio condition and are shown in Fig. 11 (a). The time responses of shaft and pressures are shown in Fig. 11 (b). The suction pressure in one cycle has two peaks and the shaft responds to the pressure variations directly.

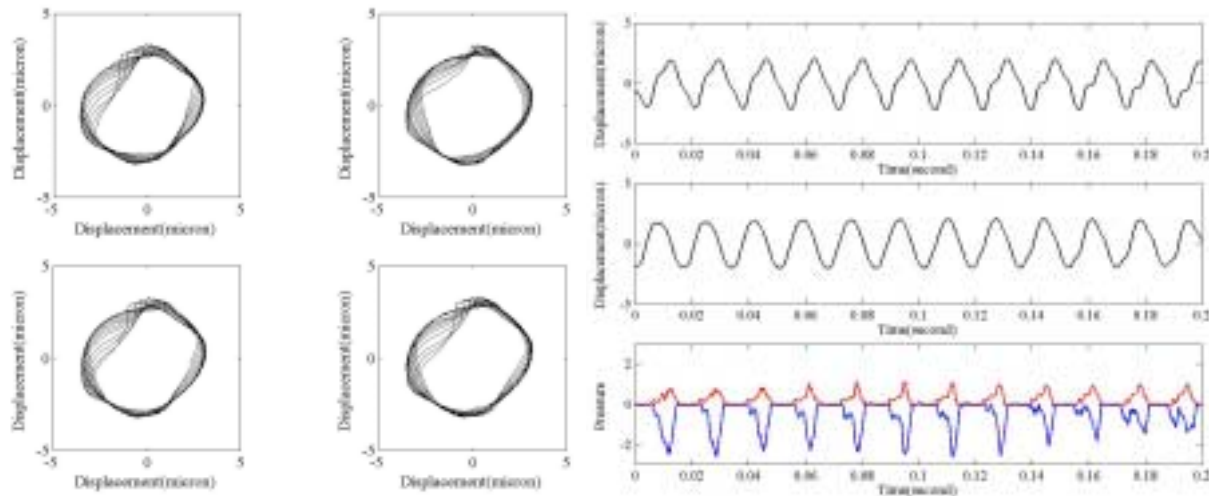

(a) Shaft orbit (b) Time signal
 Fig. 11 Steady state responses in maximum pressure ratio condition

CONCLUSION

In order to measure the shaft motion in the journal bearing of a small rotary compressor, authors develop the cylindrical capacitive sensor that is built in the journal bearing. The built-in sensor bearing is calibrated indirectly through measuring the oil relative permittivity experimentally. The shaft motion as well as suction and discharge pressures are measured in both transient and steady state conditions. The experimental results show that the developed built-in sensor bearing can measure the shaft motion very well not only in steady state but also in transient state. The developed built-in sensor bearing is expected to play a significant role in the design of journal bearing in order to ensure the stable operation of the rotary compressor.

ACKNOWLEDGEMENT

This research was supported by Carrier Ltd., Korea.

REFERENCE

- [1] Padhy, S. K., 1992, "Mathematical Modeling and Experimental Validation of a Rotary Compressor for Dynamics, Lubrication, and Heat Transfer," Ph. D. Thesis, West Virginia University, Morgantown, WV.
- [2] Hayano, M., Fukuda, T., et al., 1996, "Performance Evaluation of 2-cylinder Rotary Compressor for R410a," International Symposium on HCFC Alternative Refrigerants '96, Kobe, Japan.
- [3] Ozu, M. and Itamin, T., 1980, "Some Electrical Observations of Metallic Contact between Lubricated Surfaces under Dynamic Conditions of Rotary Compressor," Proceedings of the 1980 Purdue Compressor technology Conference, pp. 105-111.
- [4] Slocum, A. H., 1992, Precision Machine Design, Prentice-Hall, Inc.
- [5] Chapman, P. D., "A Capacitive based Ultraprecision Spindle Error Analyser," J. of Precision Engineering, Vol. 7, No. 3, July, pp. 129-137.
- [6] Ahn, H.-J., Jeon, S. and Han, D.-C., 2000, "Error Analysis of the Cylindrical Capacitive Sensor for Active Magnetic Bearing Spindles," J. of Dynamic Systems, Measurement, and Control, Trans. of ASME, Vol. 122, pp. 102-107.
- [7] 3M Co., 3M Scotch-Weld Epoxy adhesives Technical data, 3M Adhesives Division.
- [8] Huang, S. M., Green, R. G., Plaskowski, A. and Beck, M. S., 1988, "A High Frequency Stray-immune Capacitance Transducer based on the Charge Transfer Principle," IEEE Transactions on Instrumentation and Measurement, Vol. 37, No. 3, pp. 368-373.