

Purdue University
Purdue e-Pubs

International Compressor Engineering Conference

School of Mechanical Engineering

1996

Self-Adjusting Back Pressure Mechanism for Scroll Compressors

K. Tojo

Hitachi

I. Hayase

Hitachi

Follow this and additional works at: <https://docs.lib.purdue.edu/icec>

Tojo, K. and Hayase, I., "Self-Adjusting Back Pressure Mechanism for Scroll Compressors" (1996). *International Compressor Engineering Conference*. Paper 1356.

<https://docs.lib.purdue.edu/icec/1356>

This document has been made available through Purdue e-Pubs, a service of the Purdue University Libraries. Please contact epubs@purdue.edu for additional information.

Complete proceedings may be acquired in print and on CD-ROM directly from the Ray W. Herrick Laboratories at <https://engineering.purdue.edu/Herrick/Events/orderlit.html>

Self-Adjusting Back Pressure Mechanism for Scroll Compressors

Kenji Tojo

Air Conditioning & Refrigeration Systems Div. Hitachi Ltd.

390, Muramatsu, Shimizu-shi, Shizuoka-ken, 424 Japan

Isao Hayase

Mechanical Engineering Laboratory, Hitachi Ltd.

502, Kandatsu, Tsuchiura-shi, Ibaraki-ken, 300, Japan

ABSTRACT

The scroll compressor incorporates new construction concepts and is quite different from other types of compressor. This unique and simple compression mechanism has a number of advantages such as small size, light weight, high efficiency, long life, and quiet operation. The compliant mechanism is one of the key ways to improve the performance and reliability of scroll compressors. The concept of a back pressure chamber mechanism has been widely adopted to support a scroll member with axial compliance. This paper outlines some results of analytical and empirical investigations used to evaluate the effect of several parameters on the feature of back pressure mechanism and scroll compressor performance.

INTRODUCTION

Energy, resource, and space saving are still major problems in the field of compressors and their applications. Noise and vibration levels under desired operating conditions are also important considerations. To meet these demands, scroll compressors for air conditioners first came onto the market in 1983 /1/,/2/. The scroll compressors used for packaged air conditioners had an excellent reputation for their high efficiency, long life and quiet operation. Following this, scroll compressors for low temperature use and cryogenic use were developed, improving various design points /3/. In recent years, small capacity scroll compressors that can be controlled over a wide range of speeds have become common in household air conditioners /4/.

It is important to reduce leakage, heating loss, and mechanical loss to improve the efficiency and durability of the wide range of scroll compressors. The potential leakage through the axial gap is several times greater than that through the radial gap and its reduction would be a dominant factor in improving compressor efficiency. One method for controlling this leakage is to bias the scroll members together using gas loading with the lowest frictional force and wear /5/,/6/.

ANALYTICAL MODEL

A cross-sectional view of a scroll compressor and an analytical model are shown in Fig. 1 and Fig. 2 respectively. Behind the orbiting scroll, a well-designed back pressure chamber is provided. The back chamber is tapped to the intermediate compression gas pockets through the small passage on the orbiting scroll base plate. Lubricating oil in the compressor shell is supplied into the back chamber to assure the lubrication of scroll members and the driving mechanism. The back chamber is pressurized at an intermediate pressure between the suction and discharge pressures, and this pressure pushes the orbiting scroll toward the fixed scroll thus maintaining the sealing arrangement of compression gas pockets with axial compliance.

In the analytical model, refrigerant gas and lubricating oil in the back chamber are assumed to be mixed homogeneously and to flow in or out through the tapped passage in one of the 6 flow patterns classified in Fig. 3. The oil supply into the back chamber and the volume flow rate through the tapped passage are given respectively by,

$$\frac{d}{dt} v_{db} = \frac{I}{\rho_{ld}} \left(\frac{P_d - P_b}{l_{db}} \right) - \frac{I}{2} \left(\frac{\lambda_{db}}{d_{db}} + \frac{\xi_{db}}{l_{db}} \right) |v_{db}|^2 \cdot \frac{v_{db}}{|v_{db}|} \quad \text{----- (1)}$$

$$\frac{d}{dt} v_m = \frac{I}{\rho_m} \left(\frac{P_b - P_m}{l_m} \right) - \frac{I}{2} \left(\frac{\lambda_m}{d_m} + \frac{\xi_m}{l_m} \right) |v_m|^2 \cdot \frac{v_m}{|v_m|} \quad \text{----- (2)}$$

where, λ_{db} and λ_m are friction coefficients at the passages, and ξ_{db} and ξ_m are friction loss coefficients at the inlet or outlet of the passages.

The mass of the gas and oil in the back chamber are obtained as follows.

$$\frac{d}{dt} G_{bg} = A_{db} \rho_{ld} (\alpha_d - \alpha_b) v_{db} - A_m \rho_m X_m v_m \quad \text{----- (3)}$$

$$\frac{d}{dt} G_{bl} = A_{db} \rho_{ld} (1 - (\alpha_d - \alpha_b)) v_{db} - A_m \rho_m (1 - X_m) v_m \quad \text{----- (4)}$$

The pressure in the back chamber is given by,

$$\frac{d}{dt} P_b = P_b \left\{ \frac{\kappa}{G_{bg}} \frac{T_{bg^i}}{T_{bg}} \frac{dt}{d} G_{bg^i} - \frac{\kappa}{G_{bg}} \frac{dt}{d} G_{bg^o} - \frac{\kappa}{V_{bg}} \frac{dt}{d} V_{bg} \right\} \quad \text{----- (5)}$$

where, α_b , and α_d are solubility of the refrigerant in the lubricating oil, and X_m is the quality

of the mixture in the back chamber.

The pressure in the compression gas pockets are calculated in the same way, considering leakage between neighboring gas pockets and the mist flow in or out through the back pressure passage.

RESULT AND DISCUSSION

The back pressure chamber is connected to the intermediate compression gas pockets during each shaft rotation via the back pressure passages. The pressure change in the compression gas pockets and the back chamber, the mist flow rate through the back pressure passage, and the oil flow rate into the back chamber are shown in Fig. 4. Where $Q_m > 0$, the gas flows from the back chamber to the compression gas pockets. On the other hand, if $Q_m < 0$, the gas flows from the compression pockets to the back chamber. As shown in these figures, a small amount of gas drawing in and out through the back chamber passage expands the pressure line outward during the compression process while the passage is open to the gas pockets.

The characteristics of the back chamber mechanism is affected by several factors which include oil flow rate, effective passage flow area, rotational speed and so on. The effect of supplying oil into the back chamber is shown in Fig. 5 and compare calculated values with measured ones. An increase in the amount of oil supplied into the back chamber corresponds to a higher back pressure level and larger oil content of the mixture in the back chamber. On the other hand, when the oil supply is reduced too far, the sealing performance of the oil drops and its lubricating ability also drops thus leading to lower compressor efficiency and durability. Therefore the amount of oil supplied should be optimized according to the required operating condition.

The relation between rotational speed and the features of the back pressure chamber mechanism is shown in Fig. 6 compared with measured value. As is evident from these figures, the lower the rotational speed is, the bigger the pressure rise in p-v diagram due to increased leakage between neighboring gas pockets and the higher the pressure level in the back chamber are.

CONCLUSIONS

The characteristics of a scroll compressor with a back pressure chamber mechanism was investigated and an analytical model for evaluating several parameters was developed. In this model, the influence of oil flow supplied into the back chamber and the effective flow area of the back pressure passage were both considered. The oil flow rate, effective flow area, and

rotational speed proved to influence not only the average pressure level but also the condition of the oil-refrigerant gas mixture in the back chamber. This analytical model is expected to contribute to further improvements in the efficiency and durability of scroll compressors.

REFERENCES

- /1/ Ikegawa M., Sato E., Tojo K., Arai A., and Arai N., "Scroll Compressor with Self-adjusting Back Pressure Mechanism", ASHRAE Transactions 90(2), (1984).
- /2/ Tojo K., Ikegawa M., Shiibayashi M., Arai N., Arai A., and Uchikawa N., "A Scroll Compressor for Air Conditioners", Proceedings of the International Compressor Engineering Conference (Purdue), (1984).
- /3/ Tojo K., Arata T., Tomita T., Shiibayashi M., and Uchikawa N., "Scroll Compressors for Air Conditioning and Refrigerating", Proceedings of the International Congress of Refrigeration, (1987).
- /4/ Takebayashi M., Sekigami K., Tsubono I., Kousokabe H., Suefuji K., and Inaba K., "Performance Improvement of a Variable-speed Controlled Scroll Compressor for Household Air Conditioners", ASRAHE Transactions, 100(1), (1994).
- /5/ Tojo K., Ikegawa M., Maeda N., Machida S., Shiibayashi M., and Uchikawa N., "Computer Modeling of Scroll Compressor with Self Adjusting Back-pressure Mechanism", Proceedings of the International Engineering Compressor Conference (Purdue), (1986).
- /6/ Bush J. and Elson J. "Scroll Compressor Design Criteria for Residential Air Conditioning and Heat Pump Applications" Proceedings of the International Engineering Compressor Conference (Purdue), (1988).

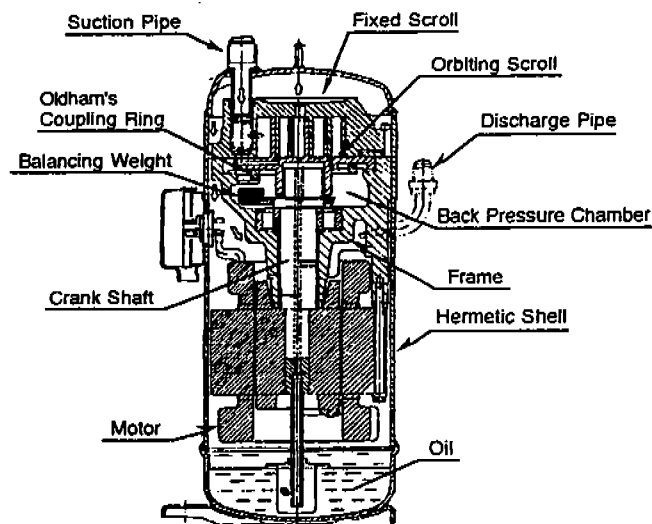

Fig. 1 Scroll compressor

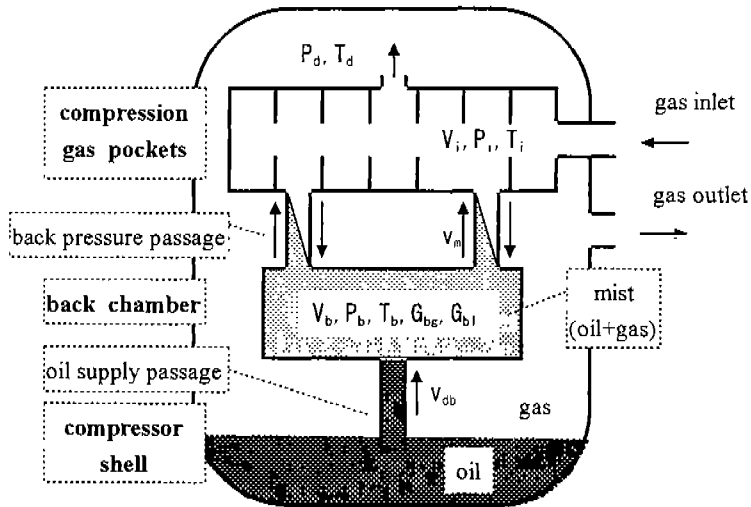

Fig. 2 Analytical model

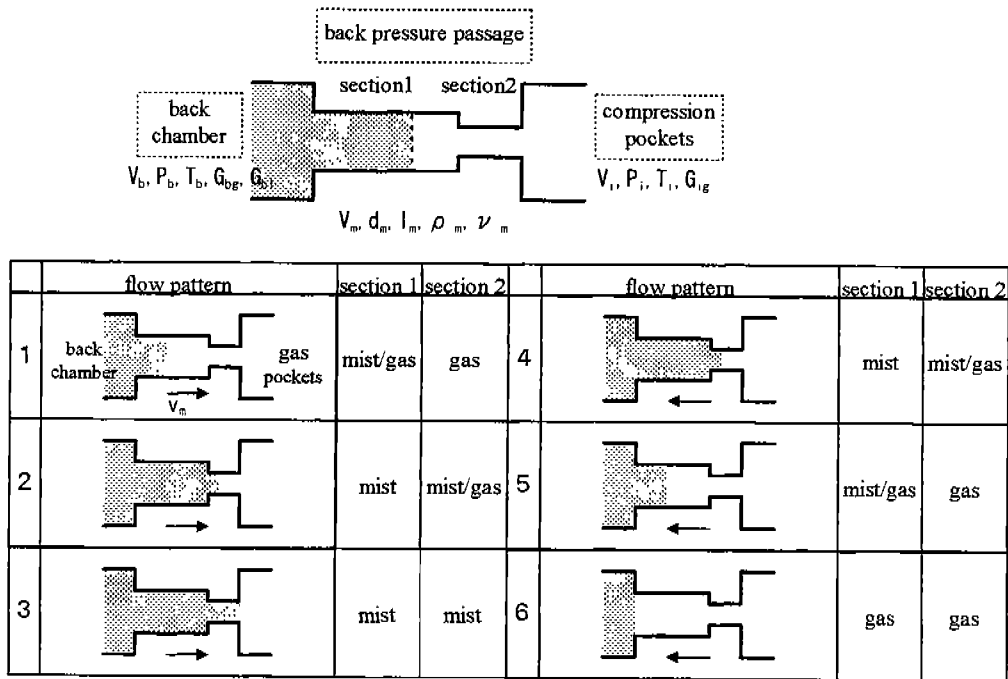

Fig 3. Flow pattern of mist fluid passing through the back pressure passage

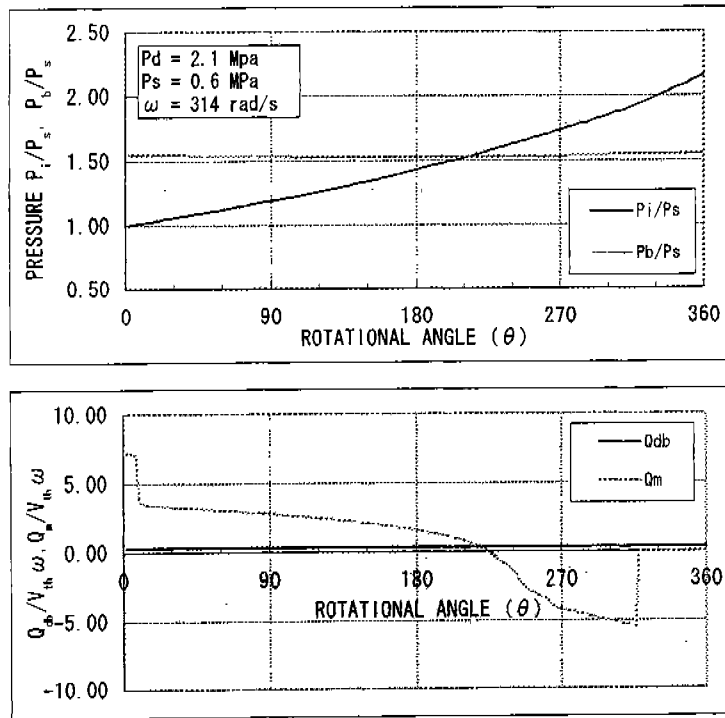

Fig.4 Characteristics of back pressure chamber mechanism

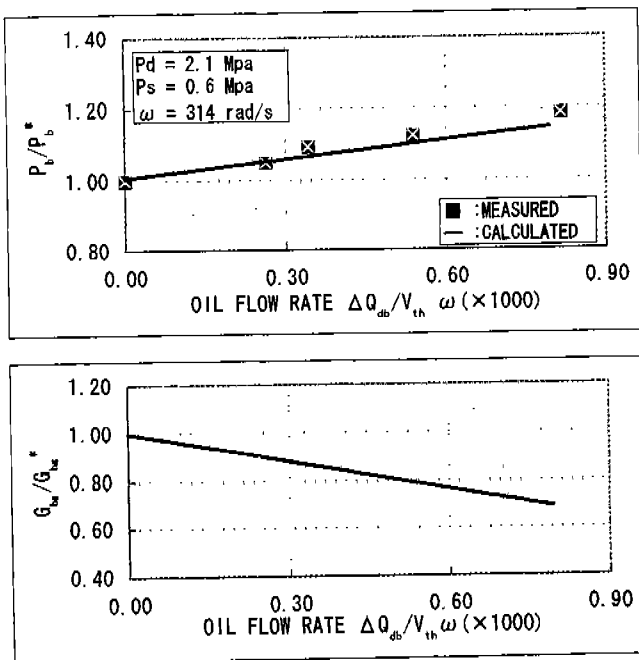

Fig. 5 Effect of oil supplied into the back chamber

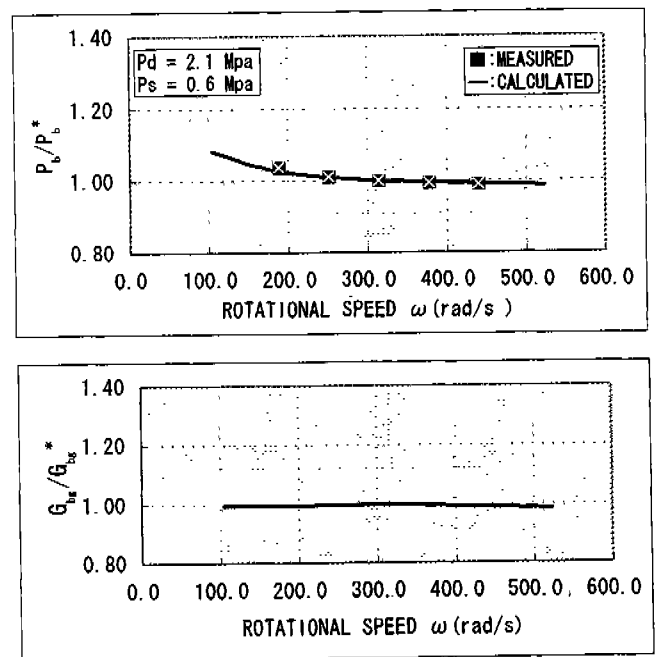

Fig. 6 Effect of rotational speed