

**Purdue University**  
**Purdue e-Pubs**

---

International Compressor Engineering Conference

School of Mechanical Engineering

---

1994

# A Co-Rotating Scroll Compressor for Positive Displacement and Centrifugal Dual-Mode Operations

E. Morishita  
*The University of Tokyo*

M. Sekiya  
*Mitsubishi Electric Industrial Corporation*

O Yatsuki  
*Mitsubishi Electric Industrial Corporation*

Follow this and additional works at: <https://docs.lib.purdue.edu/icec>

---

Morishita, E.; Sekiya, M.; and Yatsuki, O, "A Co-Rotating Scroll Compressor for Positive Displacement and Centrifugal Dual-Mode Operations" (1994). *International Compressor Engineering Conference*. Paper 1054.  
<https://docs.lib.purdue.edu/icec/1054>

This document has been made available through Purdue e-Pubs, a service of the Purdue University Libraries. Please contact [epubs@purdue.edu](mailto:epubs@purdue.edu) for additional information.

Complete proceedings may be acquired in print and on CD-ROM directly from the Ray W. Herrick Laboratories at <https://engineering.purdue.edu/Herrick/Events/orderlit.html>

# A CO-ROTATING SCROLL COMPRESSOR FOR POSITIVE DISPLACEMENT AND CENTRIFUGAL DUAL-MODE OPERATIONS

**Etsuo MORISHITA**

Department of Aeronautics & Astronautics  
Faculty of Engineering, the University of Tokyo  
7-3-1, Hongo, Bunkyo-ku, Tokyo 113, JAPAN

**Mutsuo SEKIYA      Osamu YATSUKI**

Sanda Works, Mitsubishi Electric Corporation  
2-3-33, Miwa, Sanda, Hyogo 669-13, JAPAN

## ABSTRACT

The co-rotating mechanism is utilized for scroll vacuum pump application by one of the authors. It was found that the co-rotating scroll compressor is transformed to a centrifugal compressor by reducing the eccentricity between the two scrolls to zero. The authors propose a co-rotating scroll compressor which works not only as a positive displacement compressor, but also as a centrifugal one in this paper. The multiple scroll wraps are used in the pump section for dynamic balance, which are similar to the impellers of centrifugal compressors. Design eccentricity  $r$  is used for the positive displacement operation, and the eccentricity is used for the centrifugal operation. The basic concept is described, and the preliminary results are shown.

## INTRODUCTION

Scroll compressor applications are now widespread, and not only the orbiting mechanism, but also the co-rotating mechanism can be utilized. One of the authors reported on the co-rotating scroll vacuum pump application<sup>[1]</sup>. The co-rotating mechanism is very simple in structure, and the mechanism seems to be particularly suited to light-load application like fans, blowers and vacuum pumps. One of the authors proposed a scroll fan/blower<sup>[2]</sup>, which utilized the two scroll wraps for the driving and driven scrolls. The two scroll wraps make the rotating parts statically and dynamically balanced. In the co-rotating scroll vacuum pump application, a single wrap scroll is used, and we need a huge balance weight to minimize the vibration from the centrifugal force. The scroll fan/blower has no synchronous mechanism like the Oldham coupling<sup>[2]</sup>, and the driven scroll wrap is directly driven by the driving scroll wrap, i.e., by the traction drive. This technique is also utilized in small oil-flooded co-rotating scroll vacuum pumps. The direct traction drive by the scroll wrap is possible simply because the machine has a light load.

During the course of the co-rotating scroll machine development, one of the authors found that the co-rotating machine can be transformed quite easily to a centrifugal dynamic compressor by reducing the eccentricity between the axes of the driving and driven scrolls. The radial and axial compliant mechanisms are readily applicable also to the co-rotating scroll machine, and, therefore, the eccentricity between the two scrolls is easily changed. In the co-rotating machine, the direction of the radial

compliance does not change during a rotation, and it is rather easy to control the eccentricity.

### PRINCIPLES OF OPERATION

Figure 1 shows the geometric parameters of a balance-type scroll<sup>[2]</sup>. Two scroll wraps are employed to achieve a perfect mechanical balance.

The operating principle is shown in Fig.2. The directions of the rotation are all counter-clockwise in the figure. One of the scrolls is called the driving scroll ( bold line in the figure), and is directly connected with an electric motor. The other scroll is called the driven scroll. No synchronous coupling is employed in the present application, and the driven scroll is driven directly by the wrap of the driving scroll.

The scroll rotates around its own axis, as shown in the top of Fig. 2. The scroll machine is usually employed as a positive displacement machine, and this is shown in the bottom line of Fig. 2. The driving and driven scrolls rotate around their own axes, and both axes are separated by distance  $r (=p/4-t)$ , which corresponds to the crank radius of the orbiting machine. When distance  $r$  is reduced, and the driving and driven scrolls rotate co-axially, and the scroll machine works in the centrifugal dynamic compressor mode. The direction of the flow is reversed in the centrifugal mode. The air is taken from the central port of the machine and discharged outward radially. The direction of the rotation is counter-clockwise, and it does not change in either case. It is known experimentally that the clockwise rotation in Fig.2 causes a mechanical locking of the two scrolls without a proper synchronizing means.

### DESIGN THEORY

The design theory of the rotating balance-type scroll machine was already given by the authors for the positive displacement mode<sup>[2]</sup>. The displacement volume, forces due to gas pumping, the torque, and the seal line length are obtained analytically. This machine experiences the four pulsations during a rotation in the positive displacement mode, while the conventional scroll compressor experiences a single pulsation during a rotation. The pulsations can be modified by increasing the number of wraps of the rotating scroll. The present scroll parameters are shown in Fig.1. The displacement volume is 95.4 cc/rev., and the build-in volume ratio of the machine is one.

The aerodynamic characteristics of the present rotating scroll machine in the centrifugal dynamic mode might be treated in exactly the same manner as the centrifugal pumps and compressors. Specific work  $\Delta W$  done on the fluid is equal to the total enthalpy rise, and is given by the Euler's pump equation as follows:

$$\Delta W = U_2 C_{2\theta} (=h_{01} - h_{02}) \quad (1)$$

where  $U$  is the scroll impeller tip speed,  $C$  is the absolute velocity of the fluid,  $h_0$  is the total enthalpy, the suffix 1 is the inlet, 2 is the outlet, and  $\theta$  is the tangential direction. We assume no inlet swirl velocity here ( $C_{\theta 1} = 0$ ) for simplicity. The tangential component of absolute velocity  $C_{2\theta}$  may be calculated as

follows:

$$C_{20} = \sigma(U_2 - C_{2r} \tan \beta) \quad (2)$$

where  $\sigma$  is the Stodola slip factor<sup>[3]</sup>,  $\beta$  is the impeller blade (scroll wrap) angle measured from the radial direction, and suffix  $r$  is the radial direction. Blade angle  $\beta$  is calculated from the geometry of an involute of a circle, which is employed for the present scroll wrap.

$$\beta = -\tan^{-1} \phi \quad (3)$$

where  $\phi$  is the extension angle of the involute of a circle.  $\phi = 3.5\pi$  is employed in the present application, and, therefore,  $\beta = -84.8$  degrees. The impeller leans strongly forward, and the total enthalpy (total pressure for the present incompressible case) rise increases theoretically as the flow rate increases.

### PRELIMINARY EXPERIMENT

The experimental data was already obtained for the positive displacement mode<sup>[2]</sup>. The results are repeated in Fig. 3. The machine is a dry type, and the efficiency may be satisfactory for a small machine in this class.

The characteristics of the rotating scroll fan/blower in the centrifugal dynamic mode are shown in Fig. 4. The absolute value of the pressure rise (= atmospheric discharge pressure - throttled suction pressure), together with the flow rate, is not so high because the rotational speed is in the same range as that of the positive displacement mode. The result shows that pressure rise coefficient  $\psi (= \Delta P / [\rho U_{20}^2])$ ,  $\Delta P$ : total pressure rise,  $\rho$ : density of air) is nearly constant against flow coefficient  $\phi (= Q / [\pi D^2 U_{20}])$ ;  $D$ : impeller tip diameter,  $Q$ : volume flow rate), and different from the ideal theory. The overall efficiency of machine  $\eta$  (Eff in Fig. 4), including the mechanical and the motor losses, was found to be very low in this range of rotational speed. This is due to the fact that theoretical work  $\Delta W (= Q \Delta P$  for the present incompressible case) done on the fluid itself is very small at the present rotational speed, compared to the losses involved.

### CONCLUDING REMARKS

It was found that the co-rotating scroll machine could be utilized as a centrifugal dynamic compressor, which is usually employed as a positive displacement machine. The operating principle is shown, and basic consideration is given when it operates as a centrifugal compressor. The preliminary experimental data was given. Future work is being considered on the high speed operation of a centrifugal compressor.

### REFERENCES

- [1] Morishita, E. et al, Rotating Scroll Vacuum Pump, 1988 ICEC at Purdue, July 1988, pp.198-205.
- [2] Morishita, E and Kakuda, M., Scroll Fan and Blower (in Japanese), Journal of J.S.M.E.(B), Vol.54 No.498, February 1988, pp.442-445.
- [3] Dixon, S.L., Fluid Mechanics, Thermodynamics of Turbomachinery, Pergamon, 1978, pp.201-208.

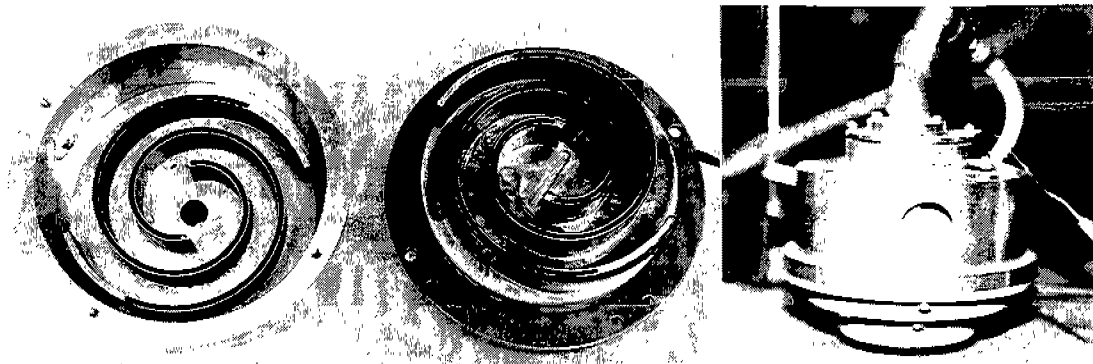
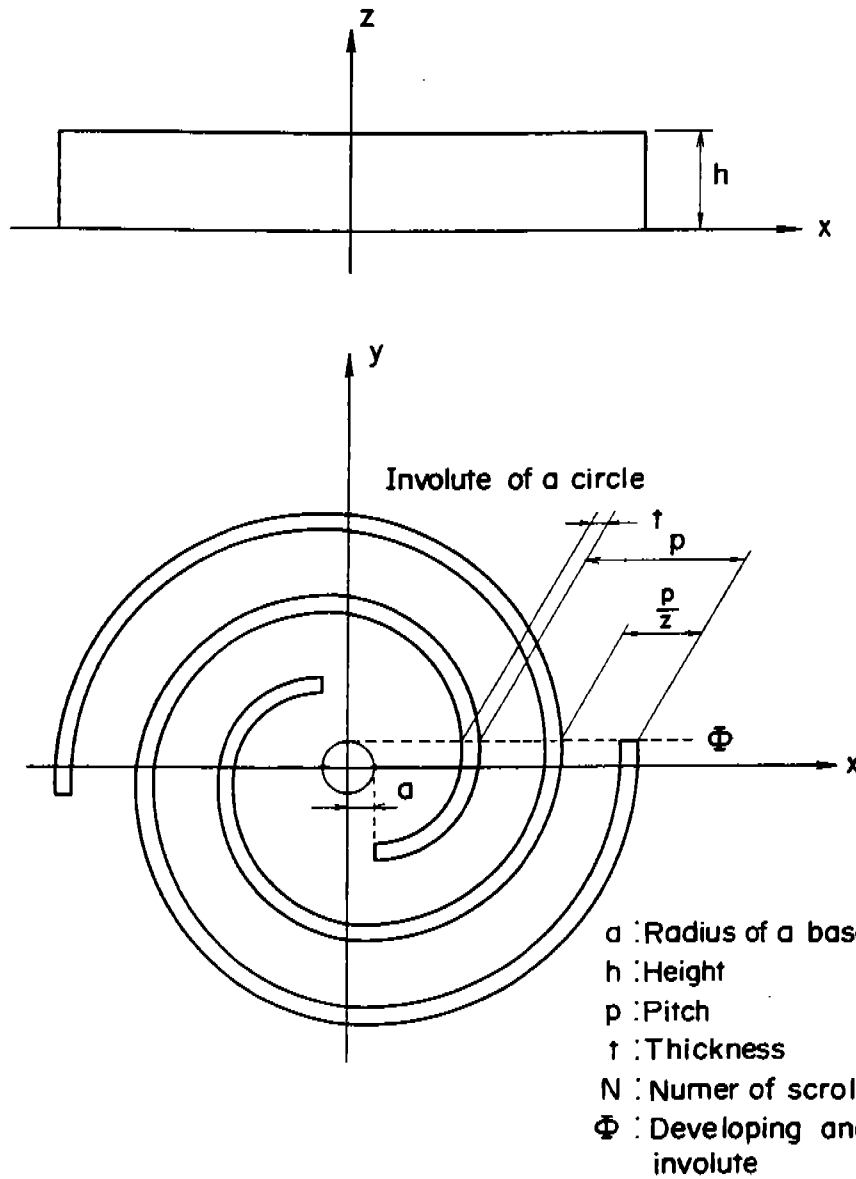

**Fig.1 Geometric Parameters and Prototype**

[Prototype:  $a=15/\pi$  mm  $h=25$ mm  $p=30$ mm  $t=3$ mm  $N=2$   $\pi < \Phi < 3.5\pi$  displacement  $V=95.4$ cc/rev build-in volume ratio=1]

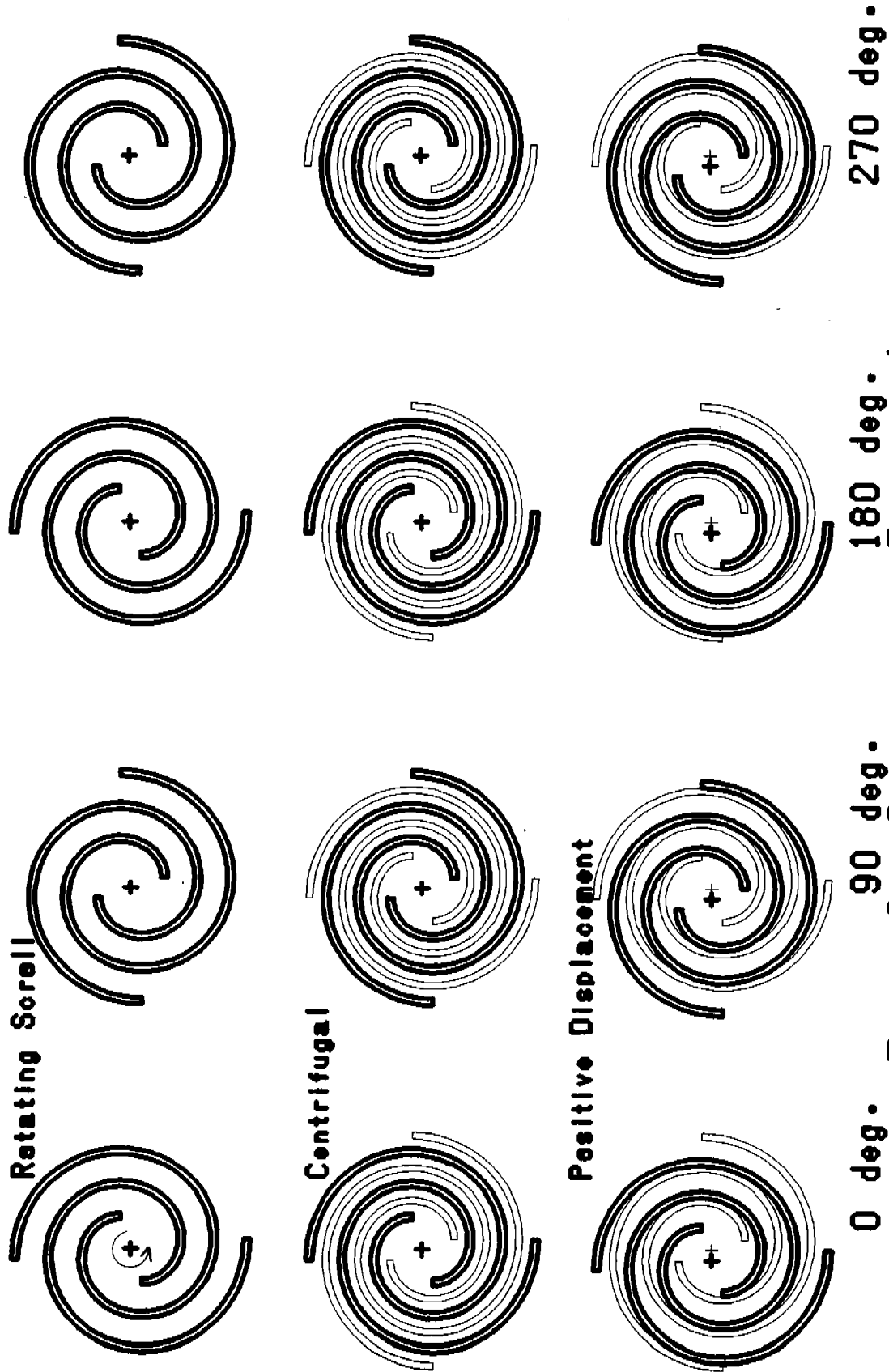

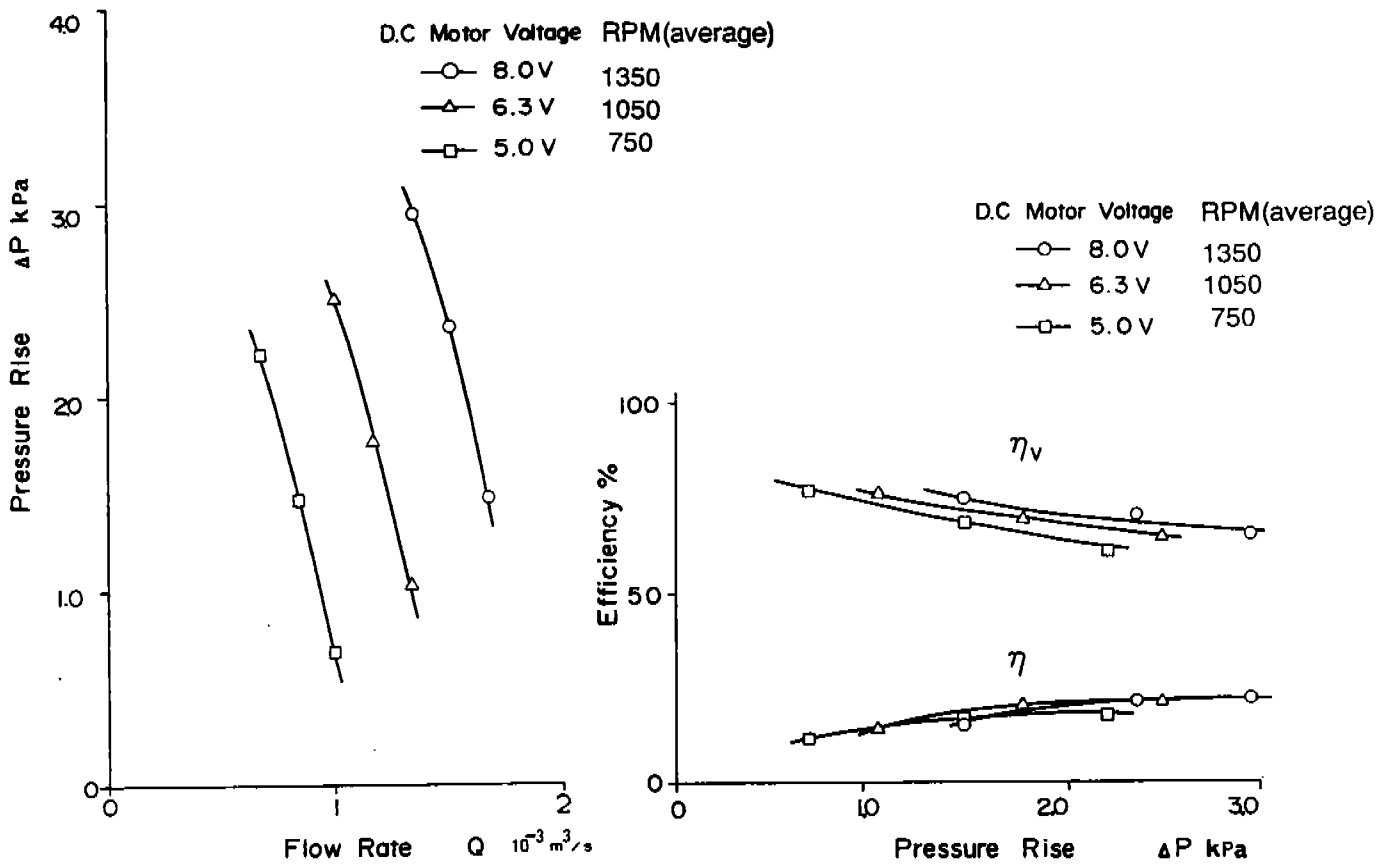

Fig. 3 Positive Displacement Compressor Mode [2]

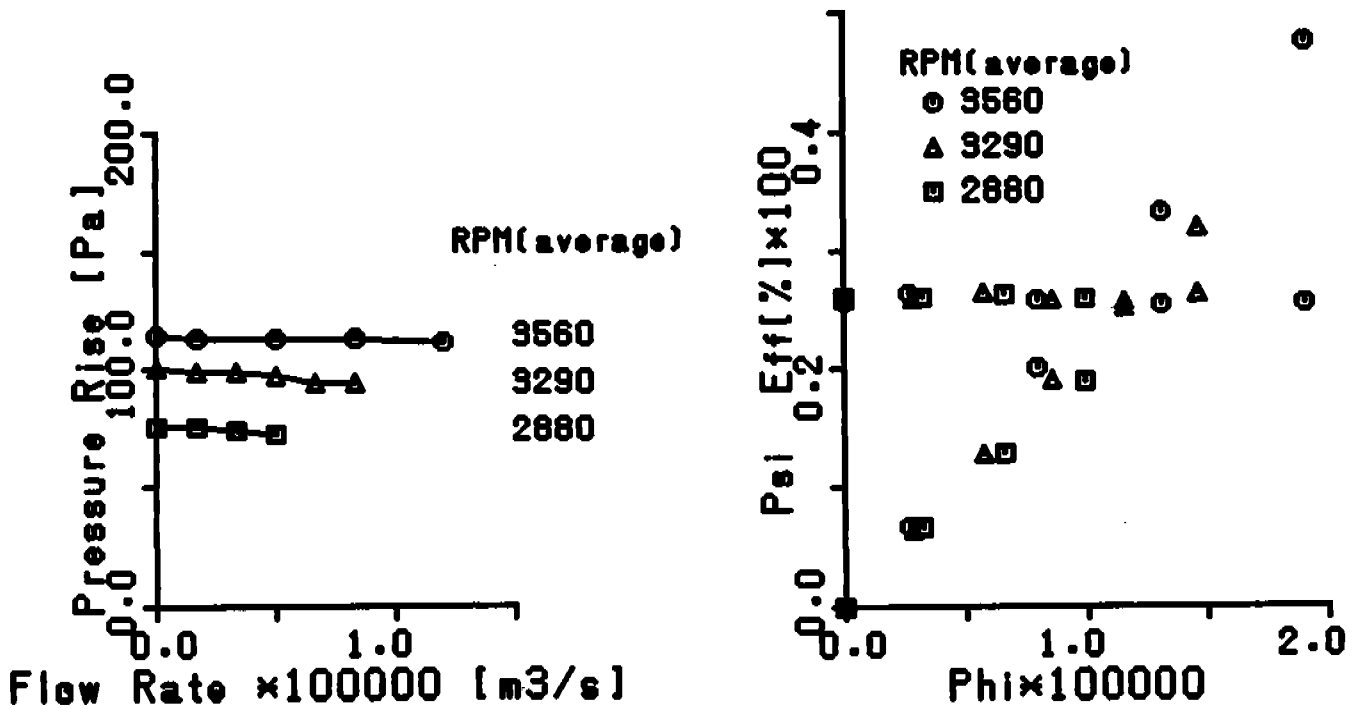

Fig. 4 Centrifugal Compressor Mode