

Purdue University
Purdue e-Pubs

International Compressor Engineering Conference

School of Mechanical Engineering

1992

Journal Bearing Performance in a Scroll Compressor

H. Narumiya

Mitsubishi Electric Corporation; Japan

K. Sakaino

Mitsubishi Electric Corporation; Japan

M. Oide

Mitsubishi Electric Corporation; Japan

Follow this and additional works at: <https://docs.lib.purdue.edu/icec>

Narumiya, H.; Sakaino, K.; and Oide, M., "Journal Bearing Performance in a Scroll Compressor" (1992). *International Compressor Engineering Conference*. Paper 881.

<https://docs.lib.purdue.edu/icec/881>

This document has been made available through Purdue e-Pubs, a service of the Purdue University Libraries. Please contact epubs@purdue.edu for additional information.

Complete proceedings may be acquired in print and on CD-ROM directly from the Ray W. Herrick Laboratories at <https://engineering.purdue.edu/Herrick/Events/orderlit.html>

JOURNAL BEARING PERFORMANCE IN A SCROLL COMPRESSOR

Hiromu NARUMIYA*, Keiju SAKAINO**, Masahiko OIDE**

* Central Research Laboratory

Mitsubishi Electric Corporation

8-1-1 Tsukaguchi Honmachi, Amagasaki, Hyogo 661, JAPAN

Tel.: 81-6-497-7164 Fax: 81-6-497-7291

** Shizuoka Works, Mitsubishi Electric Corporation

ABSTRACT

The load carrying capacities of the main and sub bearings were obtained by mathematical analysis when a main shaft supported by two journal bearings is flexed by the action of plural loads. This analytical method was applied to a typical scroll compressor, and the basic performance of the bearings was calculated at selected frequencies. The misalignment tolerance and optimum bearing clearance ratio of the main and sub bearings were quantitatively evaluated, and meaningful guidelines for bearing design were obtained.

INTRODUCTION

High efficiency, low operating noise and low vibration characteristics have made the scroll compressor⁽¹⁾, together with the screw compressor, leading candidates to succeed today's reciprocating and rolling piston type compressors for many applications. A scroll compressor is typically constructed with a bearing supporting an orbiting scroll outside the two bearings supporting the main shaft. Because the load on the main shaft acts outside of the two support bearings, the load tends to bend the main shaft. In addition, the presence of assembly error in the position of these two bearings (i.e., the main and sub bearings) causes the main shaft to rotate in a twisted manner through the two bearings, so that the main bearing has to operate under extreme conditions.

The use of a roller bearing as the main bearing has been proposed as a means of reducing this twisting of the main shaft, with a ball bearing or needle bearing used for the sub bearing. As a result, there are few examples of journal bearings being used for both the main and sub bearings, and few reports in the literature regarding journal bearings other than one on experimental studies of the edge load⁽²⁾ and another on ways of reducing the bearing reaction force through optimization of a counterweight.⁽³⁾ There are virtually no reports about calculating the effect of bearing performance on overall scroll compressor performance with specific consideration given to the bending of a main shaft supported by journal bearings.

The authors report in this paper on the development of a program to obtain the overall load carrying capacity of the main and sub bearings when a main shaft

supported by two journal bearings flexes due to the load generated when refrigerant gas is compressed, and the action of the centrifugal force generated by the counterweights. This program was applied to a typical scroll compressor to compute the basic performance at selected frequencies, as well as the effect of misalignment of the main and sub bearing axes on bearing performance. Results showed that quantitative evaluation of the optimum bearing clearance ratio and main-sub bearing misalignment tolerance is possible.

ANALYSIS

The construction of the scroll compressor used for this analysis is shown in Fig. 1. The main shaft is supported by the main and sub bearings sandwiching the rotor, with the main bearing above and the sub bearing below. The loads acting on the main shaft include the load acting from the orbiting scroll (or "gas load"), a first centrifugal load 1 produced by the top counterweight 1, and a second centrifugal load 2 produced by the bottom counterweight 2.

Application of the gas load outside of these two bearings results in a relatively high bending moment acting to deform the main shaft. In addition, because of misalignment of the main and sub bearings resulting from assembly error, the main shaft is positioned at an angle to the axis of the main bearing. Therefore, at a low range Sommerfeld number, the oil film reaction force inside the main bearing does not provide the reaction force required in the main bearing, and the main shaft contacts the upper side of the main bearing. It was assumed in this analysis that the insufficient oil film reaction force is compensated for by the edge reaction force in this case, and the combined reaction force—the vector sum of the oil film and edge reaction forces—is the reaction force occurring in the bearing (see Fig. 2). It is therefore possible to quantitatively evaluate the contact force when metallic contact occurs.

The following four assumptions were also made:

- (1) Deformation of the main shaft is an amount for which the beam deflection theory can be applied.

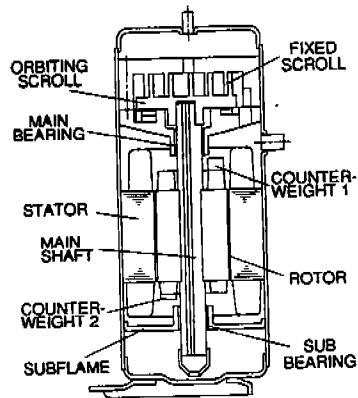

Fig. 1 Construction of the scroll compressor

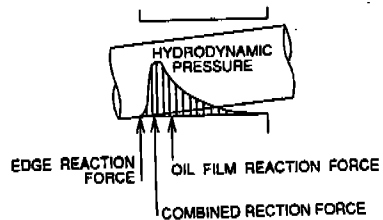

Fig. 2 Definition of the combined reaction force

- (2) Reynolds' equation of incompressible Newtonian fluids can be applied to the bearing oil film.
- (3) The loads acting on the main shaft are synchronous to the rotation and are of constant magnitude.
- (4) Deformation of the bearings can be ignored.

From assumption (3) above, the rotating load is substituted for the static load in this analysis, and an equivalence model in which the direction of shaft rotation is reversed was used.

The first step in this analysis was to compute the deformation of the shaft by applying the finite element method using the one dimensional beam element. The eccentricity ratio of the deformed shaft in both the main and sub bearings was hypothesized, the oil film state was obtained in each bearing, and Reynolds' equation

$$\frac{1}{r^2} \frac{\partial}{\partial \theta} \left(\frac{h^3}{\mu} \frac{\partial p}{\partial \theta} \right) + \frac{\partial}{\partial x} \left(\frac{h^3}{\mu} \frac{\partial p}{\partial x} \right) = 6 \frac{U}{r} \frac{\partial h}{\partial \theta}$$

where:

h: oil film thickness p: hydrodynamic pressure
 μ : oil viscosity U: shaft surface velocity

was applied. Reynolds' equation was then discretized using the finite element method, and the pressure distribution was obtained using the band matrix method. The base pressure (ambient pressure) at both sides of the bearings was defined as the boundary condition of the pressure, and was substituted for any pressure below this level. Because the bearing reaction force obtained from the first calculated pressure distribution does not balance in either magnitude or direction with the external forces acting on the shaft, this calculation is repeated until the magnitude and direction of the three external forces acting on the shaft and the two bearing reaction forces are balanced, by performing a convergence calculation using a Jacobi matrix.

BASIC CHARACTERISTICS OF THE MAIN AND SUB BEARINGS

Application of the analytical method described above to the scroll compressor shown in Fig. 1 is described below. Note that the diameter and bearing width of the main bearing of this compressor is 20 mm, the diameter and bearing width of the sub bearing is 16 mm, and the bearing span is 134 mm.

(1) Basic performance at selected frequencies

The basic performance of the main and sub bearings at selected frequencies from 15 ~ 120 Hz is shown in Fig. 3. The relationship between the positions of the loads acting on the main shaft is shown in Fig. 4. While the gas load is constant at 745 N, the two centrifugal loads increase with the frequency, and the combined

reaction forces of the main bearing and the oil film reaction force of the sub bearing increase in a corresponding manner.

It can be seen from this figure that the oil film reaction force of the main bearing is insufficient at less than 75 Hz, resulting in an edge reaction force, and that the percentage of the combined reaction force accounted for by the edge reaction force increases as the frequency decreases. In other words, the edge reaction force accounts for more than 80% of the combined reaction force at 15 Hz, and the oil film reaction force accounts for less than 20% of the total—an extreme operating condition. Furthermore, when the reaction forces of the main and sub bearings are compared it is found that the contribution of the sub bearing is less than that of the main bearing, and that this tendency is even more pronounced at lower frequencies. Thus, when the loads act outside the bearing span (main bearing) nearest the load become even more extreme.

(2) Affect of misalignment

Bearing performance was computed for those cases in which there is an offset (or "discrepancy") between the center axes of the main and sub bearings, and in which the axis of the sub bearing is at an angle (or "inclination") to the axis of the main bearing. The definitions for this discrepancy and inclination are shown in Fig 5.

The calculated bearing performance for a 30 μm discrepancy at 15 Hz is shown in Fig. 6. When the relative angle between the direction of sub bearing discrepancy and the

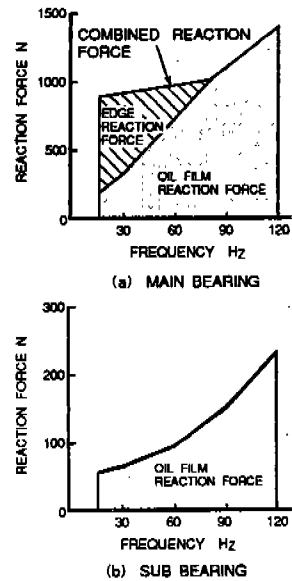

Fig. 3 Basic performance of the main and sub bearings

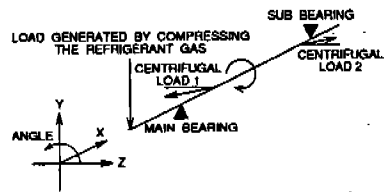

Fig. 4 Relationship between the positions of the loads acting on the main shaft

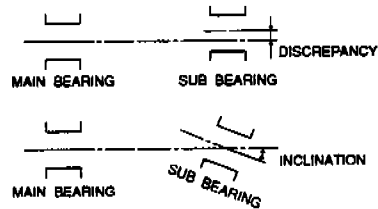

Fig. 5 Definitions for the discrepancy and inclination

direction of the gas load changes, the eccentricity ratio of the main and sub bearings fluctuates. While there always exists the edge reaction force in the main bearing, the magnitude of the oil film reaction force is greatest (270 N) when the direction of discrepancy is 270°, and is least (84.1 N) at 90°. This is because the discrepancy acts to alleviate the inclination of the shaft inside the main bearing in the former case, but has the reverse effect in the latter case. On the other hand, while there is a slight fluctuation in the eccentricity ratio of the sub bearing compared with when there is no discrepancy (0.68 and 0.73 on the upper and lower ends, respectively), it is in a constant state of hydrodynamic lubrication.

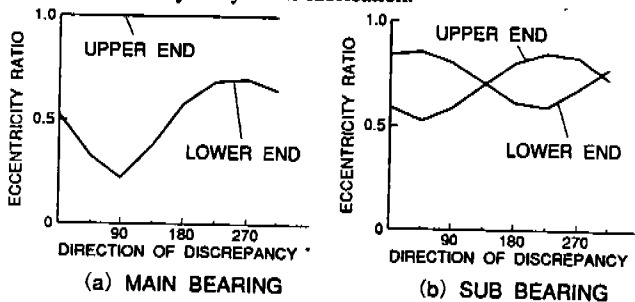

Fig. 6 Calculated bearing performance(1) (30µm discrepancy, 15Hz)

The calculated bearing performance for a 4×10^{-4} rad inclination at 15 Hz is shown in Fig. 7. There is virtually no change in main bearing performance even though the relative angle between the direction of the discrepancy and the direction of the gas load changes. In other words, the discrepancy of the sub bearing has virtually no effect on the main bearing. On the other hand, the eccentricity ratio of the sub bearing varies greatly with the direction of inclination, and becomes rather severe at the lower end at 45° and at the upper end at 225°.

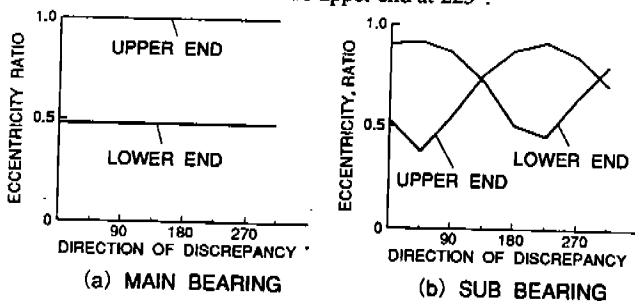

Fig. 7 Calculated bearing performance(2) (4×10^{-4} rad inclination, 15Hz)

The calculated bearing performance for a 30 µm discrepancy at 120 Hz is shown in Fig. 8. Because the centrifugal load l is 1000 N at 120 Hz, greater than the gas load of 745 N, the operating conditions of the main bearing become extreme at the lower end (the rotor end). As a result, the shaft strongly contacts the lower

side of the main bearing when the direction of discrepancy is between 90° and 225° . These conditions are most severe at 90° , at which the eccentricity ratio of the upper end is 0.99. Unlike at 15 Hz, however, the eccentricity ratio of the lower end is normally high in the sub bearing, and a constant hydrodynamic lubrication state is maintained because there is excess load carrying capacity at high speeds.

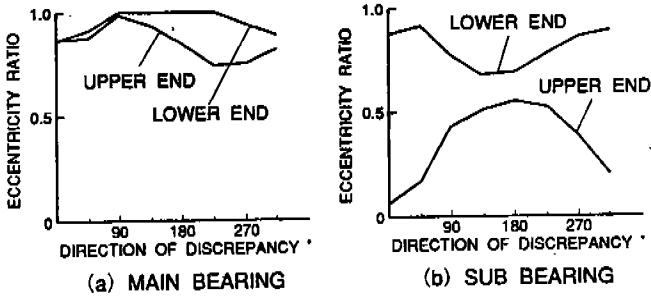

Fig. 8 Calculated bearing performance(1) ($30\mu\text{m}$ discrepancy, 120Hz)

The calculated bearing performance for a 4×10^{-4} rad inclination at 120 Hz is similarly shown in Fig. 9. As at 15 Hz, there is virtually no change in main bearing performance even though there is a change in the direction of discrepancy. On the other hand, the eccentricity ratio of the lower end of the sub bearing is high, as described above. When the direction of discrepancy is 0° and 315° , the eccentricity ratio is 0.95, which means that metallic contact almost occurs.

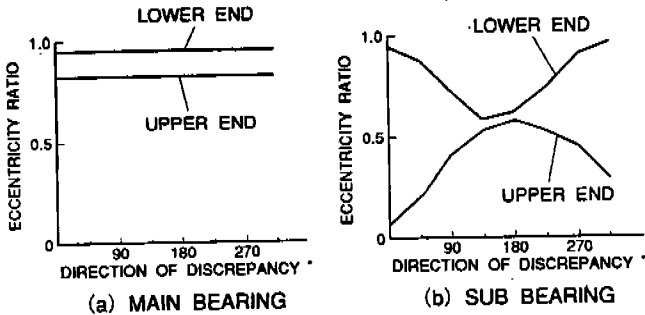

Fig. 9 Calculated bearing performance(2) (4×10^{-4} rad inclination, 120Hz)

DESIGN GUIDELINES FOR MAIN AND SUB BEARINGS

It is necessary to clarify the following three items in the design of main and sub bearings for a scroll compressor.

- (1) Determination of the limits and evaluation of the absolute values of the contact force caused by edge load on the main bearing
- (2) Determination of the tolerances for misalignment of the main and sub bearings

(3) Determination of the optimum bearing clearance ratio

We therefore prepared several graphs based on the basic characteristics described in the previous section to study the above items.

(1) Evaluations using load and velocity

The edge load on the main bearing will increase wear of the main shaft. In general, the amount of wear W can be defined by the equations

$$W = w \cdot F \cdot l = w \cdot F \cdot V \cdot T$$

where:

w : specific wear amount (m^3/Nm) V : sliding velocity (m/s)

F : load (N)

T : total sliding time (s)

l : total sliding distance (m)

If the specific wear amount w is assumed to be constant, the parameter by which the amount of wear W in a given time T can be compared is the product of the load F and the sliding velocity V ($F \cdot V$). If the edge reaction force and circumferential velocity are used as F and V , respectively, the product $F \cdot V$ can be used to evaluate the performance of the main bearing under an edge reaction force. Note that if there is any discrepancy, the magnitude of the edge reaction force will vary according to the angle of the discrepancy, but the complications of this added parameter are avoided here by using the maximum edge reaction force F_{\max} as an index for evaluation of the product $F_{\max} \cdot V$.

The $F_{\max} \cdot V$ values for the main bearing when the clearance ratio and oil viscosity were changed to 1/1000, 1.5/1000 and 2/1000, and to 3, 6, 9 and 12×10^{-3} Pa·s, respectively, to simulate conceivable standard loads are shown in Fig. 10. The parameter used here is the amount of discrepancy, and as this value increases the $F_{\max} \cdot V$ value also naturally increases.

The $F_{\max} \cdot V$ value also decreases as the clearance ratio decreases. This is because the load carrying capacity of the oil film is increased by reducing the clearance ratio when the shaft is inclined to the axis of the main bearing. In addition, the load carrying capacity of the oil film increases when the viscosity is increased and the $F_{\max} \cdot V$ value decreases. In either case, the maximum $F_{\max} \cdot V$ value decreases and the frequency at which the $F_{\max} \cdot V$ value becomes 0 decreases. In other words, we can see from the figure that both the peak height and width decrease.

To use this $F_{\max} \cdot V$ value figure to evaluate main shaft wear and define the tolerance for discrepancy, it is necessary to plot the data from wear tests over the graph. Specifically, by measuring main shaft wear under a varying clearance ratio, viscosity, discrepancy, frequency, and other conditions to determine the suitability of these conditions, and plotting plural good and bad points on the $F_{\max} \cdot V$ value graph, it is possible to obtain the $F_{\max} \cdot V$ values of the tolerance limits. Thereafter, the designer simply needs to select the oil viscosity and discrepancy tolerances so

that the $F_{max} \cdot V$ value is within these tolerances for the intended operating conditions.

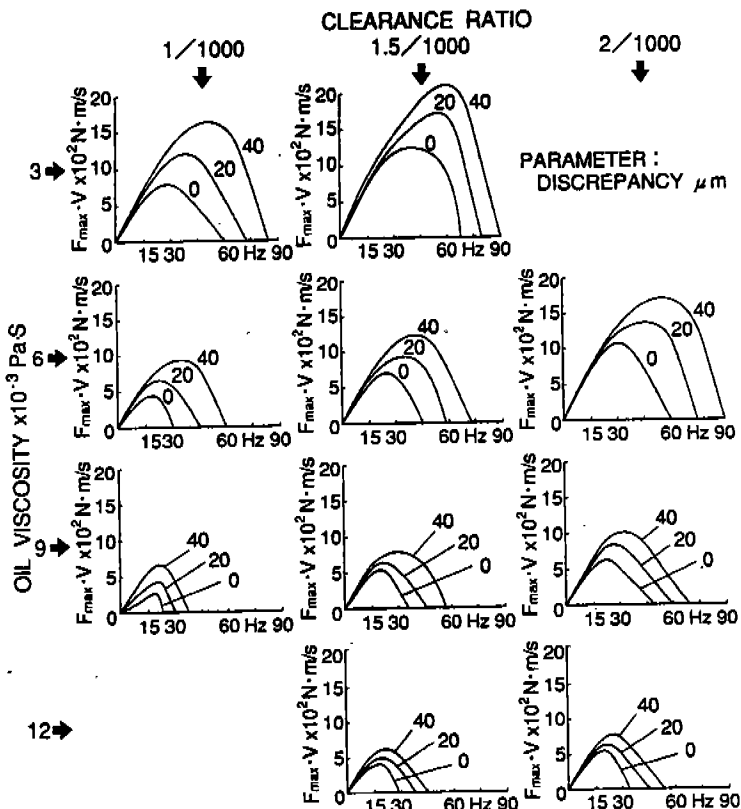

Fig. 10 $F_{max} \cdot V$ values for the main bearing

(2) Tolerance limits for inclination

The limiting factors for sub bearing inclination are shown in Fig. 11. One of these is the occurrence of metallic contact in the sub bearing at 15 Hz. Because metallic contact also occurs in the main bearing at this time, there is the possibility that the main shaft will stop turning. Another factor is the occurrence of metallic contact in the sub bearing at 120 Hz. If the stiffness of the subframe supporting the sub bearing is high, elastic deformation of the subframe cannot be expected to avoid metallic

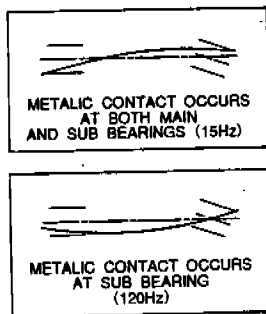

Fig. 11 Limiting factors for sub bearing inclination

contact in the sub bearing, which is then subject to extreme wear and even seizure.

The discrepancy and inclination limits under normal air conditioner operating conditions at a 3×10^{-3} Pa·s viscosity are shown in Figs. 12 and 13 for 15 Hz and 120 Hz, respectively. The relative angle of the direction of discrepancy to the direction of the inclination can be either detrimental (the discrepancy aggravates the inclination) or beneficial (the discrepancy attenuates the inclination) to the bearing. Both Figs. 12 and 13 illustrate the former (detrimental) case. In this case, the tolerance limit of the inclination decreases with an increase in the discrepancy, becoming a straight line rising to the left. This is because a $10 \mu\text{m}$ discrepancy is geometrically equivalent to an inclination of 8×10^{-5} rad.

Note that the tolerance limits (horizontal axis) for discrepancy shown by the three straight lines in Figs. 12 and 13 are the theoretical values for the change in the discrepancy tolerance at a clearance ratio of 1/1000 and 2/1000, assuming a reference discrepancy tolerance of $20 \mu\text{m}$ at a 1.5/1000 clearance ratio. Precise actual values must be obtained experimentally.

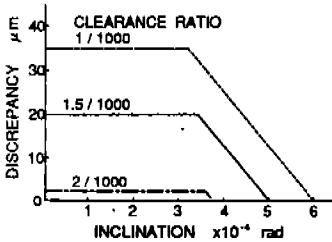

Fig. 12 Discrepancy and inclination tolerance limits(1) (15Hz)

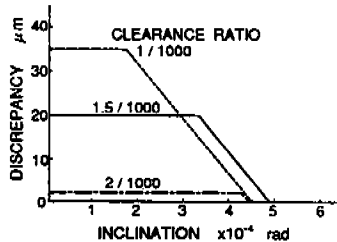

Fig. 13 Discrepancy and inclination tolerance limits(2) (120Hz)

(3) Selecting the clearance ratio

Judging from Fig. 10, it is preferable to keep the clearance ratio as close to 1/1000 as possible in order to keep the $F_{\text{max}} \cdot V$ value small. In addition, it is clear from the discrepancy and inclination tolerance limit graph at 15 Hz (Fig. 12) that a clearance ratio of 1/1000 is best for increasing tolerance. In the discrepancy and inclination tolerance limit graph at 120 Hz (Fig. 13), however, a clearance ratio of 1.5/1000 provides the greatest tolerance to inclination. Therefore, if a certain amount of latitude is allowed in the clearance ratio considering the machine tolerance and ease of equipment assembly, it is preferable to keep this within the range 1/1000 to 1.5/1000.

It should also be noted, however, that this analysis does not consider the squeeze film effect of the oil film, and the optimum bearing clearance ratio might actually be greater than this because the load carrying capacity of the oil film has been slightly underestimated.

CONCLUSIONS

A program for obtaining the overall load performance of main and sub bearings in a scroll compressor was developed, and the analytical method of this program was applied to a small capacity model in this paper. The following conclusions as regards the basic bearing characteristics and bearing design guidelines can be drawn from the results.

- (1) While operating between 15 and 120 Hz, at approximately 75 Hz or less an edge reaction force occurs in the main bearing, and the percentage of the combined reaction force accounted for by this edge reaction force increases as the frequency decreases. Also, the sub bearing constantly maintains a state of hydrodynamic lubrication.
- (2) Discrepancy affects both main and sub bearing performance, and as the relative angle of discrepancy to the direction of the gas load changes, the eccentricity ratio of both bearings changes. Inclination, however, has virtually no effect on main bearing performance, and only changes the eccentricity ratio of the sub bearing.
- (3) In order to evaluate the advance of shaft wear in the main bearing, the tolerance limit F-V value obtained from wear tests needs to be plotted on the F-V chart obtained in this study. The oil viscosity and discrepancy tolerance should be set so that the F-V value of the compressor under actual operating conditions is within these tolerance limits.
- (4) The factor restricting inclination is the occurrence of metallic contact in the sub bearing at 15 Hz and 120 Hz, and the inclination tolerance limits are shown in the tolerances graph in this report.
- (5) The clearance ratio should preferably be within the range 1/1000 ~ 1.5/1000, but this range may be slightly greater because the squeeze film effect of the oil film was not considered in this study.

REFERENCES

- (1) Morishita, et al., Scroll Compressor Analytical Model, Proceedings of the 1984 International Compressor Engineering Conference at Purdue (1984), 487.
- (2) Lane, Laub, Designing for Cantilevered Bearing Loads: Approach to Scroll Design, Proceedings of the 1988 International Compressor Engineering Conference at Purdue (1988), 1.
- (3) Nieter, DeBlois, Counterweighting Scroll Compressor for Minimal Bearing Loads, Proceedings of the 1988 International Compressor Engineering Conference at Purdue (1988), 175.