

Purdue University
Purdue e-Pubs

International Compressor Engineering Conference

School of Mechanical Engineering

1984

Application of Micro -Computer in a Performance Measurement System of Reciprocating Compressors

S. Sun

H. Yuan

Follow this and additional works at: <https://docs.lib.purdue.edu/icec>

Sun, S. and Yuan, H., "Application of Micro -Computer in a Performance Measurement System of Reciprocating Compressors" (1984). *International Compressor Engineering Conference*. Paper 489.
<https://docs.lib.purdue.edu/icec/489>

This document has been made available through Purdue e-Pubs, a service of the Purdue University Libraries. Please contact epubs@purdue.edu for additional information.

Complete proceedings may be acquired in print and on CD-ROM directly from the Ray W. Herrick Laboratories at <https://engineering.purdue.edu/Herrick/Events/orderlit.html>

APPLICATION OF MICRO-COMPUTER IN A PERFORMANCE
MEASUREMENT SYSTEM OF RECIPROCATING COMPRESSORS

Siyang Sun Heping Yuan

Xi'an Jiao-tong University, Xi'an, China

ABSTRACT

This work has developed a system measuring the performance of the reciprocating compressors to acquire accurate experimental data by using micro-computer. The characteristics of this system have made it possible to record seven channel signals simultaneously without being out of phase. The data can be accurately recorded and rapidly analyzed by means of this simple system. Compared the measurements with the computations based on simulating models, satisfactory results have been achieved.

INTRODUCTION

Digital computer has been widely used for simulating the working processes in the reciprocating compressors and optimizing the compressors design. As the mathematical simulation model is an approximation of the complex physical situation, the only way of assessing the reliability of the models is by means of experiments and by comparing computational results with experimental results. Therefore it is very important to accurately record the experimental data. This paper described the gained results through the application of micro-computer in a performance measurement system of reciprocating compressors. To acquire accurate experimental data, various performances were recorded by means of a tape data recorder at small intervals during a working cycle of the compressor. These included the pressure variation in the cylinder with the crank angle, the pressure variation in the plenum chambers, the valve plate displacement, and dead centre of the piston et al. Then the recorded signals were inputted into the micro-computer. Analog-digital conversion, data acquisition, and data analysis were conducted in a disk system. Then the digital results were provided by a printer. The indicated diagram, wave form, and valve displacement and other were graphed by a plotter. Overall procedure was controlled by a programme written in FORTRAN or extended BASIC. The measurements were carried out in a Π ZA-1.5/8 type air compressor. The gained results is satisfactory.

MEASUREMENT SYSTEM

Arrangement of the measurement system is usually dependent on the characteristics of the signals measured. For a working process of the reciprocating compressor, the signals generated in measuring some performance parameters are determinate, and relevant to the rotational speed of the compressor. In order to record the real working processes of the compressor almost without distortion, the measurement system with high accuracy and fast response is necessary. When the measurement results are especially used for assessing the computational reliability of the mathematical models of the working processes in compressors, both the signal wave forms and instantaneous values of the measurement parameters must be given by the measurement system. It is difficult for the conventional measurement (Transducer-Amplifier-Oscilloscope System) to meet the above requirements. In this case a micro-computer controlled system is considered to be realistic.

Main Performance Parameters to be Measured

1. Indicated diagram of the working processes in cylinder
2. Pulsation pressure in the suction plenum chamber
3. Pulsation pressure in the discharge plenum chamber
4. Suction valve plate displacement
5. Discharge valve plate displacement
6. Phase of the piston displacement

All the above six parameters are complex periodic function. Thus they can be expanded into Fourier series. The signal waveform is integral times the waveform of fundamental frequency. As the simulating signals change continuously, it might be possible to decrease the demand for the speed of the data acquisition system.

Compressor and Measurement Point Arrangement

The experiments were conducted in a vertical air compressor, Type Π ZA-1.5/8, with two

cylinders of single acting, and water cooling. For the compressor, air displacement $V=90\text{m}^3/\text{hr}$, discharge pressure $P_d=8 \times 10^5 \text{ N/m}^2$, rotating speed $n=524\text{r.p.m.}$, phase of crankangle $\delta=180^\circ$. In the experiments the real discharge pressure $P_d=5 \times 10^5 \text{ N/m}^2$. The measurement point arrangement is given in Fig.1.

Block Diagram for Measurement System

The system may simultaneously record the multiplex waves and their instantaneous amplitudes during stable operation of a reciprocating compressor. In this case a TEAC SR-20C DATA Recorder was employed. It can simultaneously accommodate seven-channel signals with various speeds for recording and playback. The signals recorded by SR-20 DATA Recorder were inputted into a micro-computer through an analog-digital converter. The instantaneous amplitudes of the waveform were provided by a printer. The signal waveforms were graphed by a plotter. The block diagram is shown in Fig.2.

Data Acquisition and Treatment Method

After the overall measurement system was arranged and connected, the instruments should be switched on and pre-heated to eliminate the zero drift and obtain the reliable data. The compressor having been operated with stability, the wave form for each channel was investigated by means of a cathode ray oscilloscope. The waveform amplitude was properly adjusted, and the disgusting interference signal was eliminated.

The DATA Recorder was started and the data were recorded. The length of the recorded signal sample should meet the requirements of that the total time for recording the signal sample, $T=(50-100)T_p$, where $T_p=60/n$. n was the rotating speed of compressor. In general the lower recording speed in the instrument should not be chosen, even though the lower recording speed may meet the requirements of the signal frequency response. The recording speed $v=9.5\text{cm/sec}$ was employed in the experiments. The speed is located on the middle position of the speed adjuster in the instrument. This is convenient for the subsequent data analysis.

The signals recorded by the tape were stored in the micro-computer through the analog-digital converted. A 12 bit converter was used. The input voltage is ± 2 volts. The sampling frequency is 1 kHz for using six channels. As the signals were inputted into the micro-computer, it was important to choose the tape speed of the recorder. If the playback was conducted with the same speed as recording, 9.5cm/sec , one signal can be acquired at 3.3° intervals of the crankangle rotation. When the playback tape speed decreased to 2.4cm/sec , one signal can be acquired at 0.8° intervals of the crankangle rotation. Thus the acquisition system with lower speed can be used to obtain high sampling accuracy.

It can be seen from the block diagram of the measurement system that the analog-digital converter was worked in the manner of scanning. The scanning time interval between successive channels was $120\mu\text{s}$. Thus the phase of the acquired signals between successive channels was 0.3° (For operating condition of the measured compressor). A specially designed software was used to correct the phase caused by the scanning intervals of the analog-digital converter.

The conversion data were stored in the micro-computer in the form of voltage value. The dimension of pressure and displacement can be converted from the voltage by means of computer software system. The converting correlation was determined by the final calibration. The dimension of pressure can be thus obtained by the calibrating correlation which was inputted in the computer.

Correction to the fundamental line must be done for the measured indicating diagrams, pressure pulsation waveforms, and valve displacement curves. Because the recorded zero potential was not equal to the practical zero pressure (atmospheric pressure) or zero displacement. The zero line drift was caused by the temperature. To keep no difference between the measured signal and real operating condition, the measurement data should be multiplied by a factor k .

RESULTS AND ANALYSIS

Fig.3 shows the measurement curves graphed by the micro-computer controlled plotter. It is clearly indicated that the pressure pulsation in the plenum chamber and the unreasonable motion of the valve plate have influence on the suction and discharge processes. A stiffness spring was consciously employed to obtain the plate oscillation. Thus the relationship between the valve plate motion and the flow pulsation can be investigated. It is indicated in Fig.3 that the high frequency wave of the pressure pulsation in the plenum chamber is generated by the valve oscillation. Furthermore this leads to the pressure variation in suction and discharge processes in the cylinder. For the two-cylinder compressor used in the experiments (alternate angle of crank= 180°), suction and discharge occur two times separately in the plenum chamber for each rotary. Thus two peaks appear in the pulsation pressure curve of the plenum chamber. The phase of the peaks in the graphed curves is rather coincident.

Comparison was made between the simulating curves of the working processes calculated by computer and the measurement curves, as shown in Fig.4.

The mathematical models for simulating the working processes may be written as:

1. Energy equation (1)

$$\frac{dT}{d\theta} = \left[\left(\frac{1}{v} \left(\frac{\partial h}{\partial v} \right)_T - \left(\frac{\partial p}{\partial v} \right)_T \frac{dv}{d\theta} - \frac{1}{v_c} \left(\frac{dm_i}{d\theta} (h_1 - h) \right) + \frac{dQ}{d\theta} - \frac{dm_o}{d\theta} (h_2 - h) = \sum \frac{dm_{op}}{d\theta} (h_p - h) \right] / \left(\left(\frac{\partial p}{\partial T} \right)_v - \frac{1}{v} \left(\frac{\partial h}{\partial T} \right)_v \right)$$

2. Gas state equation (2)

$$\frac{Pv}{RT} = 1 + \sum_{i=1}^n \beta_i(T) \rho_i$$

Here for the working processes of a single stage air compressor, $\sum_{i=1}^n \beta_i(T) \rho_i$ term is negligible.

3. Continuity equation (3)

$$\frac{dm}{d\theta} = \frac{dm_i}{d\theta} - \frac{dm_o}{d\theta} - \sum \frac{dm_{op}}{d\theta}$$

4. Change law of the working volume (3)

$$\frac{dV_c}{d\theta} = \pm F \frac{S}{Z} \left[\sin\theta + \frac{\bar{\lambda} \sin\theta \cos\theta}{\sqrt{1 - \bar{\lambda}^2 \sin^2\theta}} \right]$$

5. Heat transfer equation

$$\frac{dQ}{d\theta} = \frac{1}{\omega} \alpha(\theta) \left\{ [\bar{T}_3(\theta) - T] F_3(\theta) + [\bar{T}_M - T] F_M + [\bar{T}_K - T] F_K \right\}$$

6. Valve plate motion equation

$$\frac{d^2 H_i}{d\theta^2} = \left[\beta_i A_i (P_i - P) - Z P_i' (\Delta H_i + H_i) \right] / M_i \omega^2$$

For easy in modelling computation, one dimension unsteady flow equation system describing the pulsating flow were not introduced into the models. The real pressure pulsation recording values were directly inputted into computer.

The above differential equation system was solved by using the Rung-Kutta numerical method. The variation of the computed pressure in cylinder with the crankangle was graphed into the indicating diagram, as shown by the broken line in Fig.4. The measured indicating diagram was represented by the actual line. Practically the difference between them was very small. The difference between them only occurred in the expansion process due to the difference between the actual clearance and the assumed clearance in the computation. The coincidence between the measurement curve and computational curve indicated not only the validity of the models and the accuracy of the approximate solution, but also the reliability of the microcomputer controlled compressor performance measurement system.

CONCLUSIONS

The compressor performance measurement through a microcomputer controlled data acquisition-analysis system is a very important manner to assess the validity of the modelling computation for the compressor working processes. The

method introduced in the paper is viable. While the microcomputer system acquires the data, the phase among the channels may be completely eliminated by using a designed software system. Thus the data outputted from the various channels are synchronous. The measurement curves are in good agreement with the computed curves.

NOTATION

T	Instantaneous gas temperature in cylinder
θ	Crank angle
v	Instantaneous specific volume of gas in cylinder
V_c	Instantaneous volume of cylinder
P	Instantaneous pressure of gas in cylinder
m	Instantaneous mass of gas in cylinder
m_i	Total mass of gas in cylinder flowed from suction valve
m_o	Total mass of gas flowed out from cylinder through discharge valves
m_p	Mass of gas flowed out through piston and stuffing box
h_1	Specific enthalpy of gas entering cylinder
h_p	Specific enthalpy of leak gas
h_2	Specific enthalpy of gas flowed out from cylinder
h	Instantaneous specific enthalpy of gas in cylinder
Q	Heat transferred to actuating medium
$\alpha(\theta)$	Heat transfer coefficient
$\bar{T}_3(\theta)$	Average temperature on working surface of cylinder
$\bar{T}_M(\theta)$	Average temperature on piston surface
\bar{T}_K	Average temperature on cylinder cover surface
$F_3(\theta)$	Working surface area of cylinder
F_M	Surface area of piston
F_K	Surface area of cylinder cover
H_i	Valve plate lift
β_i	Lift coefficient
P_i	Pressure, in front of valve (i=1), behind valve (i=2)
P_i'	Spring stiffness coefficient
ΔH_i	Spring precompression
Z_i	Number of spring
M_i	Mach number
A_i	Nominal passageway area of valve base; suction valve (i=1), discharge valve (i=2)
$\bar{\lambda}$	Ratio of the rotational radius of

- crank shaft to the length of connecting rod
- F Piston area
- S Piston stroke
- ω Angular velocity of crank

REFERENCES

- (1) Ng, e.H., Tramschek, A.B., MacLaren, J.F.T., Computer Simulation of a Reciprocating Compressor Using a Real Gas Equation of State, Proc. 5th Purdue Compressor Technology Conference, 1980

- (2) Gosney, W.B., Principles of Refrigeration, Combridge University Press, London, 1982
- (3) Plastinin, P.I., Tvachrelidze, A.K., Introduction to Mathematical Modelling of Reciprocating Compressors, Moscow Higher Technical University, Moscow, 1976
- (4) Chang, K.Y., Kerr, S.V., MacLaren, J.F.T., a Versatile Micro-Computer Controlled High Speed Data Acquisition System Applied to Compressors, Proc. 6th Purdue Compressor Technology Conference, 1982

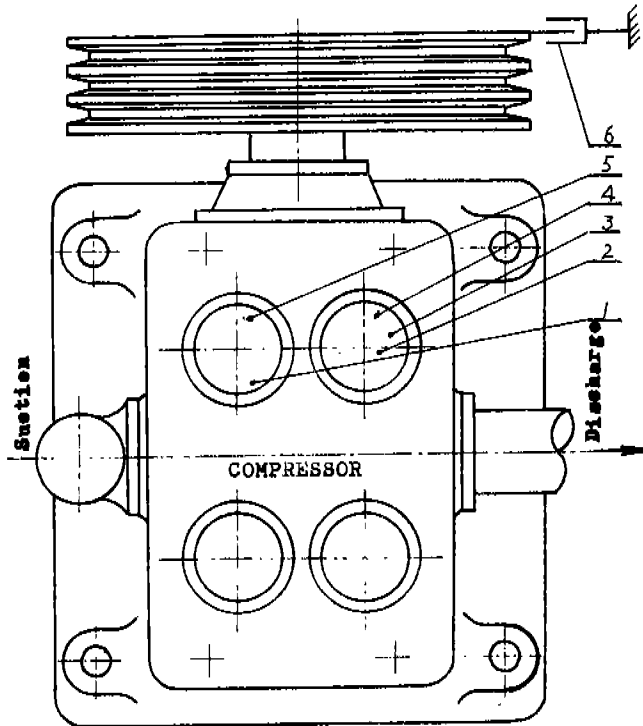

Fig. 1. Measurement point arrangement.

- 1) Pulsation pressure in suction plenum chamber
- 2) Indicated diagram of the working processes in cylinder
- 3) Pulsation pressure in discharge plenum chamber
- 4) Discharge valve plate displacement
- 5) Suction valve plate displacement
- 6) Phase of the piston displacement

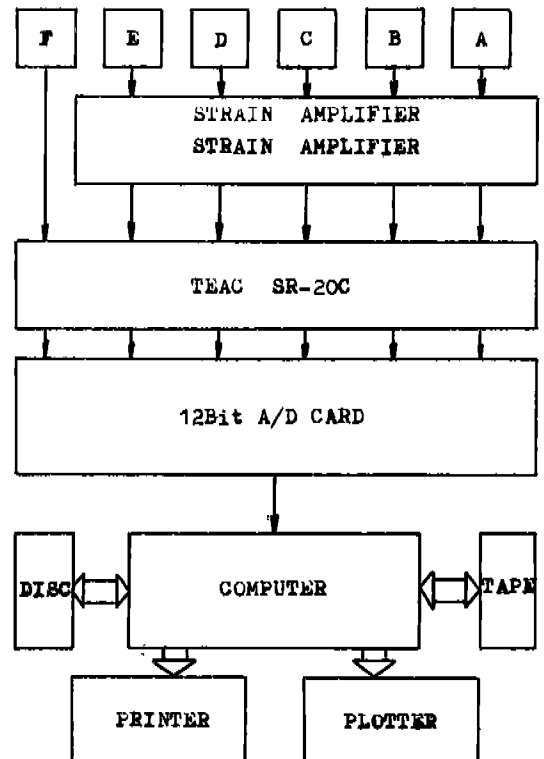

Fig. 2. Block diagram for the measurement system

- A) Pressure transducer for measuring pressure pulsation in suction plenum chamber
- B) Pressure transducer for measuring indicated diagram
- C) Pressure transducer for measuring pressure pulsation in discharge chamber
- D) Inductance transducer for measuring discharge valve displacement
- E) Inductance transducer for measuring suction valve displacement
- F) Light and electric transducer for measuring the dead centre

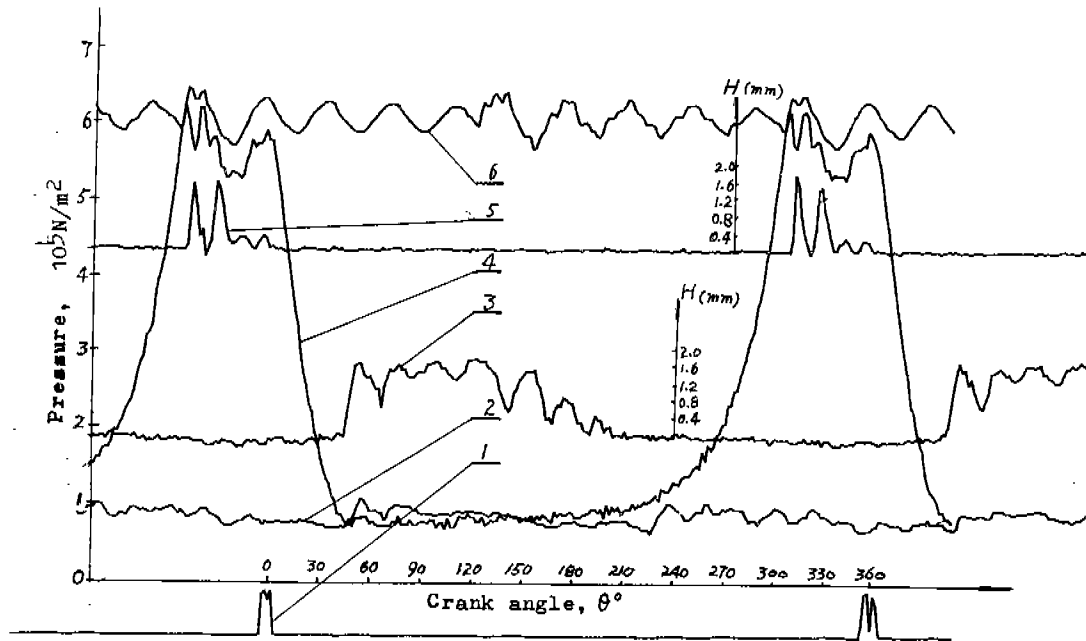

Fig. 3. Measurement curves

- 1) Phase of the piston displacement
- 2) Pulsation pressure in the suction plenum chamber
- 3) Suction valve plate displacement
- 4) Indicated diagram of the working processes in cylinder
- 5) Discharge valve plate displacement
- 6) Pulsation pressure in the discharge plenum chamber

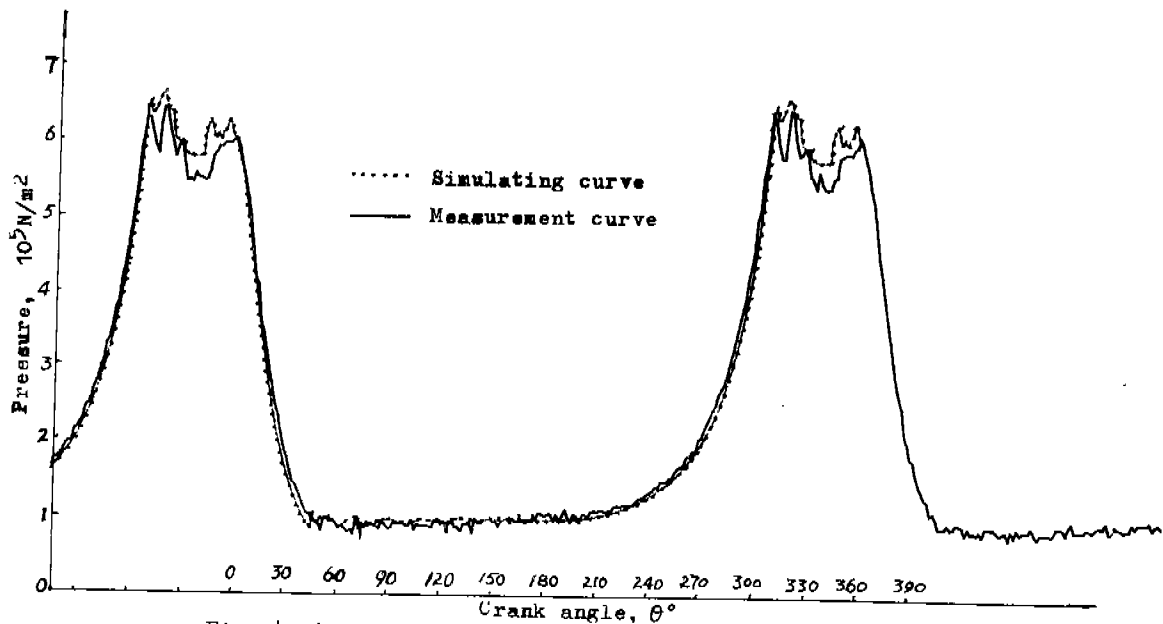

Fig. 4. Comparison was made between the simulating curves of the working processes by computer and the measurement curves