

Purdue University
Purdue e-Pubs

International Compressor Engineering Conference

School of Mechanical Engineering

1982

Motion of Rolling Piston in Rotary Compressor

K. Okada

K. Kuyama

Follow this and additional works at: <https://docs.lib.purdue.edu/icec>

Okada, K. and Kuyama, K., "Motion of Rolling Piston in Rotary Compressor" (1982). *International Compressor Engineering Conference*. Paper 391.

<https://docs.lib.purdue.edu/icec/391>

This document has been made available through Purdue e-Pubs, a service of the Purdue University Libraries. Please contact epubs@purdue.edu for additional information.

Complete proceedings may be acquired in print and on CD-ROM directly from the Ray W. Herrick Laboratories at <https://engineering.purdue.edu/Herrick/Events/orderlit.html>

MOTION OF ROLLING PISTON IN ROTARY COMPRESSOR

Katsumi OKADA, Dr. Research Engineer
Central Research Laboratory
Mitsubishi Electric Corp.
Amagasaki, Hyogo, Japan

and Kimio KUYAMA, Manager
Shizuoka Works
Mitsubishi Electric Corp.
Shizuoka, Shizuoka, Japan

ABSTRACT

This paper describes the behavior of a rolling piston in a rolling piston type rotary compressor under various operating conditions. Kinematic behavior of the rolling piston is discussed with attention to the friction forces acting on the rolling piston and the vane. Emphasis is on the following simulation approach.

- (1) The equation of motion of the rolling piston is solved in conjunction with the equilibrium equations of forces acting on the vane.
- (2) The following three cases of contact between the vane tip and the rolling piston are examined by comparing the ratio of the tractive force to the contacting force with the coefficient of friction.
 - A. Sliding Contact: the rolling piston rubs the vane tip in the same direction as the eccentric shaft rotates.
 - B. Rolling Contact: no sliding between the vane tip and the rolling piston.
 - C. Sliding Contact: the direction of sliding is opposite to that in the state A.

The analysis for a typical refrigerating compressor leads the following results.

- (1) The trajectory of a point on the side surface of the rolling piston looks like a trochoid. It suggests that the rolling piston rotates slowly in the same direction as the eccentric shaft rotates and that the revolution rate of the rolling piston is not constant but varies periodically.
- (2) The friction force at the tip of the vane fluctuates continuously or sometimes its direction abruptly changes. This affects the angular velocity of the rolling piston.

Using this analysis, the kinematic behavior of the rolling piston can be easily predicted under various kinds of dimensions and operating conditions.

INTRODUCTION

The rolling piston in a rolling piston type compressor plays a part of partition between the vane and the rotor. In the design of actual compressor, there is requirement that the wear of the vane tip should be decreased to the minimum. The wear of the vane tip should be affected by the behavior of the rolling piston. However, the behavior of the rolling piston may be very complicated because it is not decided geometrically but ruled by the fluctuating frictional forces acting on the rolling piston.

The behavior of the rolling piston has been interested in by many investigators [1-4]. The authors attempted to analyse the behavior of the rolling piston [1]. The two frictional forces were considered to rule the behavior of the rolling piston. One of them is the Coulomb's frictional force acting on the contacting point between the vane tip and the rolling piston. Another frictional force is the fluid film friction generated within the thin oil film between the rolling piston and the eccentric. The angular velocity of the rolling piston was calculated by solving the equation of motion in conjunction with the two frictional forces. T. Shimizu also analyzed the behavior of a rolling piston with attention to another frictional force; the viscous dragging force between the rolling piston and the cylinder head [2]. These studies were both made with computer aided analyses because of those complexities. P. Pandeya and W. Soedel analyzed kinematics of a rolling piston type rotary compressor with more simple and practical formulae [3]. All the three analyses above mentioned were not confirmed by any experiments. J. Tanizaki, T. Shimizu and T. Shiga performed an experiment to confirm the behavior of the rolling piston [4]. Referring to this experimental results, it is noticed that the rolling piston rotates slowly to the same direction as the eccentric rotates and the angular velocity of the rolling piston is not constant but varies periodically. The similar behavior was already predicted in the reference [1]. It is now considered that the analytical way of study such as the reference [1] may be available to predict the behavior of the rolling piston. This paper describes the behavior of rolling piston under various operating conditions and different dimensions.

NOMENCLATURE

a	Length of vane (m)
b	Thickness of vane (m)
c	Clearance between piston and eccentric (m)
e	Eccentricity of shaft (m)
F_V	Tangential force acting on vane tip (N)
I	Moment of inertia of piston (kgm^2)
L	Length of cylinder (m)
l_c	Length of eccentric (m)
N	Eccentric's revolutions per second (s^{-1})
n	Specific heat ratio of refrigerant gas
P_s	Suction pressure (Nm^{-2})
P_d	Discharge pressure (Nm^{-2})
$p(\theta)$	Pressure in compression chamber at angle θ (Nm^{-2})
P_o	Oil film pressure developed in lubricant beneath inner surface of piston (Nm^{-2})
R	Radius of cylinder (m)
r_o	Radius of piston (m)
r_1	Radius of eccentric (m)
r_2	Radius of vane tip (m)
T_r	Friction torque between piston and eccentric (Nm)
U	Sliding velocity between piston and eccentric (ms^{-1})
$V(\theta)$	Volume of compression chamber at angle θ (m^3)
v	Sliding velocity between vane and piston (ms^{-1})
ω_1	Angular velocity of eccentric (s^{-1})
ω_2	Angular velocity of piston (s^{-1})
ω_3	Angular velocity of concentrated load acting on eccentric (s^{-1})
η	Viscosity of lubricant (Nsm^{-2})
μ_1	Coefficient of friction between vane and slot
μ_2	Coefficient of friction between vane and piston
μ_3	Ratio of tangential force to contacting force at point of contact between vane and piston
ϕ	Sliding/rolling ratio at point of contact between piston and cylinder
χ	Eccentricity of journal in bearing
\mathcal{G}	Eccentric angle of journal in bearing
ψ_1	Angle of oil film existence

MOTION OF ROLLING PISTON

Pressure Acting on Rolling Piston

The cross sectional view of a typical rolling piston type compressor is shown in Fig. 1. Referring to Fig. 1, the volume $V(\theta)$ can be geometrically given as follows:

$$V(\theta) = \frac{L}{2} \left[\left(\theta + \frac{3}{2}\pi \right) R^2 + \left(e \sin \theta + \sqrt{r_o^2 - e^2 \cos^2 \theta} \right) e \cos \theta - r_o^2 \left(\theta + \frac{3}{2}\pi - \sin^{-1} \left[\frac{e \cos \theta}{r_o} \right] \right) \right] \quad (1)$$

where

$$\theta = \frac{\pi}{2} - \omega_1 t \quad (2)$$

Since in the compression stroke the following equation is held, the pressure $p(\theta)$ can be expressed by equation (4).

$$pV^n = \text{constant} \quad (3)$$

$$p(\theta) = P_s \left\{ \frac{\pi(R^2 - r_o^2)L}{V(\theta)} \right\}^n \quad (4)$$

In this paper, it is assumed that the pressure $p(\theta)$ can not be increased over the discharge pressure P_d . Then, the pressure $p(\theta)$ may be

$$p(\theta) = P_d \quad (5)$$

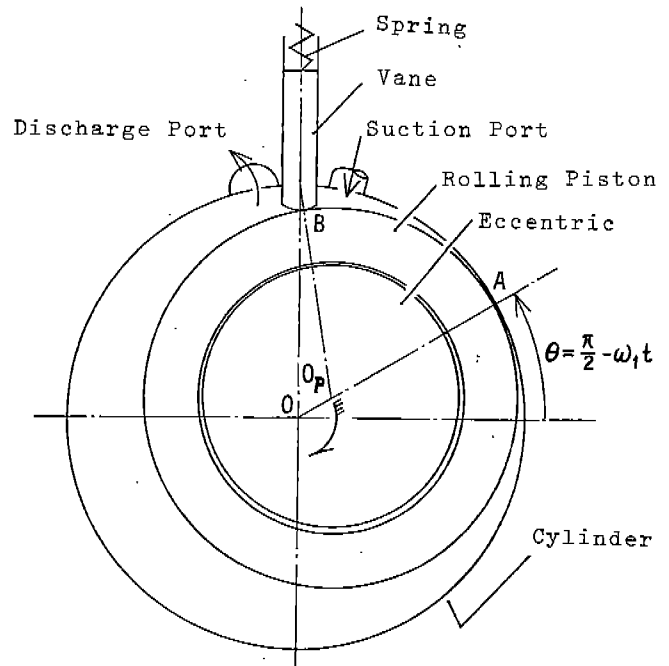

Fig. 1 Cross-section of a typical rolling piston compressor

Pressure Load on Rolling Piston

The load W_p acting on the rolling piston due to the gas pressure distribution, as shown in Fig. 2, is given as follows:

$$\begin{aligned} W_p &= L \{ p(\theta) - p_s \} \overline{AB} \\ &= L \{ p(\theta) - p_s \} \sqrt{2r_o^2 \left\{ 1 - \cos \left[\theta + \frac{3}{2}\pi - \sin^{-1} \left(\frac{e \cos \theta}{r_o} \right) \right] \right\}} \end{aligned} \quad (6)$$

And the argument of $\arg \vec{W}_p$ is given by the following equation.

$$\arg \vec{W}_p = \frac{\theta}{2} + \frac{1}{2} \sin^{-1} \left(\frac{e \cos \theta}{r_o + r_2} \right) + \frac{\pi}{4} \quad (7)$$

Forces Acting on Vane

Many forces act on the vane as shown in Fig. 3. The spring force W_{v1} together with the gas pressure load W_{v2} act behind the vane. The contacting force W_v

and the tangential force F_v act on the top of the vane. The force W_{H3} acting on the side surface of the vane due to the compression pressure is larger than W_{H2} due to the pressure in the inlet chamber. So that the vane should be pressed to the slot wall near the suction port. Then the reaction force W_{H2} and the friction force W_{v4} act on the side surface of the vane.

Another slot wall reaction force W_{H1} and the friction force W_{v5} also act on the tail of the vane. The spring force W_{v1} , the pressure load W_{v2} , the inertia force W_{v3} , the pressure load W_{H3} and W_{H4} can be easily obtained as a function of the angle θ of the eccentric. The other forces, W_{H1} , W_{H2} , W_v and F_v , should be obtained by solving the following equilibrium equation.

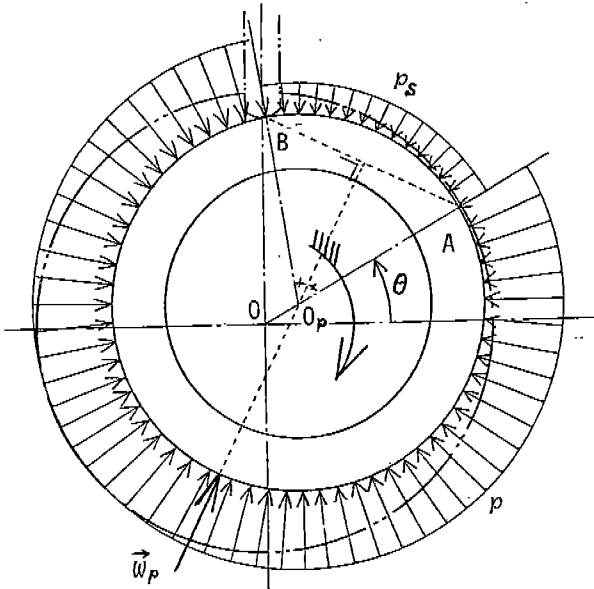

Fig. 2 Pressure distribution on rolling piston

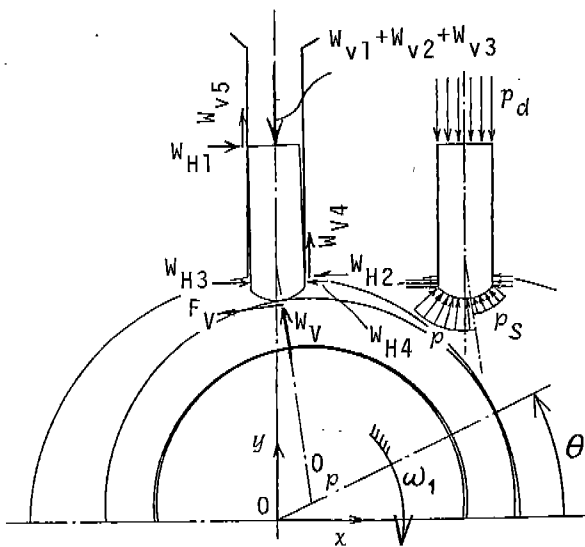

Fig. 3 Forces acting on vane

Equilibrium to the x direction:

$$W_{H1} + W_{H2} + W_{H3} + W_{H4} + \frac{e \cos \theta}{r_o + r_2} W_v + F_v \sqrt{1 - \left(\frac{e \cos \theta}{r_o + r_2}\right)^2} = 0 \quad (8)$$

Equilibrium to the y direction:

$$W_{v1} + W_{v2} + W_{v3} + W_{v4} + W_{v5} - W_v \sqrt{1 - \left(\frac{e \cos \theta}{r_o + r_2}\right)^2} + F_v \frac{e \cos \theta}{r_o + r_2} = 0 \quad (9)$$

Equilibrium of moment about the shaft center o:

$$W_{H1} \{a - r_2 + e \sin \theta + (r_o + r_2) \sqrt{1 - \left(\frac{e \cos \theta}{r_o + r_2}\right)^2}\} + R W_{H2} + \frac{1}{2} (W_{H3} + W_{H2}) \{R - r_2 + e \sin \theta + (r_o + r_2) \sqrt{1 - \left(\frac{e \cos \theta}{r_o + r_2}\right)^2}\} + \left\{ \frac{e \cos \theta}{r_o + r_2} W_v + F_v \sqrt{1 - \left(\frac{e \cos \theta}{r_o + r_2}\right)^2} \right\} \{e \sin \theta + (r_o + r_2) \sqrt{1 - \left(\frac{e \cos \theta}{r_o + r_2}\right)^2} - r_2\} = 0 \quad (10)$$

When the relative motion between the vane-top and the rolling piston is of pure sliding, the following Coulomb's law of friction is considered to be applicable.

$$F_v = \frac{v}{|v|} \mu_2 W_v \quad (11)$$

Where v is the sliding velocity at the vane-piston contacting point. The velocity v is represented as

$$v = \omega_1 e \left\{ 1 + \frac{e}{r_o + r_2} \cos^2 \theta - \sin \theta \cdot \sqrt{1 - \left(\frac{e \cos \theta}{r_o + r_2}\right)^2} \right\} - \omega_1 R \phi \quad (12)$$

Where ϕ is the slipping/rolling ratio at the piston-cylinder contacting point. If $\phi = 0$, the relative motion between the rolling piston and the cylinder is of pure rolling and if $\phi = 1$, the motion is of pure sliding. In practice, the value of ϕ is considered to be $0 \leq \phi \leq 1$. Referring to equation (12), the sliding velocity v will change with ϕ . It can be considered that there are three kinds of relative motion between the vane-top and the rolling piston.

- (1) The rolling piston rubs the top of the vane from the side of the suction port to the side of the delivery port as shown in Fig. 4 (a). This kind of motion will occur when $v > 0$.
- (2) The sliding direction of the rolling piston against the vane is opposite to that in the case of (1) when $v < 0$ as shown in Fig. 4 (b).
- (3) The relative motion between the vane-top and

the rolling piston is of pure rolling when $v = 0$.

In the cases (1) and (2), the contacting force W_V can be obtained as the following equation by substituting equation (11) into equations (8), (9), and (10).

$$W_V = \frac{\begin{vmatrix} C_1 & -C_1 & D_1 \\ 1 & 1 & D_2 \\ C_4 & C_5 & D_3 \end{vmatrix}}{\begin{vmatrix} C_1 & -C_1 & C_2 \\ 1 & 1 & C_3 \\ C_4 & C_5 & C_6 \end{vmatrix}} \quad (13)$$

Where,

$$\left. \begin{aligned} C_1 &= \frac{\cos\theta}{|\cos\theta|} \mu_1 \quad (\cos\theta \neq 0) \\ C_2 &= -\sqrt{1 - \left(\frac{e\cos\theta}{r_o+r_2}\right)^2} + \mu_2 \frac{e\cos\theta}{r_o+r_2} \frac{v}{|v|} \quad (v \neq 0) \\ C_3 &= \frac{e\cos\theta}{r_o+r_2} + \mu_2 \frac{v}{|v|} \sqrt{1 - \left(\frac{e\cos\theta}{r_o+r_2}\right)^2} \\ C_4 &= a - r_2 + e\sin\theta + (r_o+r_2) \sqrt{1 - \left(\frac{e\cos\theta}{r_o+r_2}\right)^2} \\ C_5 &= R \\ C_6 &= C_3(C_4 - a) \\ D_1 &= -(W_{V1} + W_{V2} + W_{V3}) \\ D_2 &= -(W_{H3} + W_{H4}) \\ D_3 &= \frac{1}{2} D_2 (C_4 - a + R) \end{aligned} \right\} (14)$$

In the case of (3), the force W_V is given by the following equation by assuming a value of F_V . The tangential force of F_V may be decided to a suitable

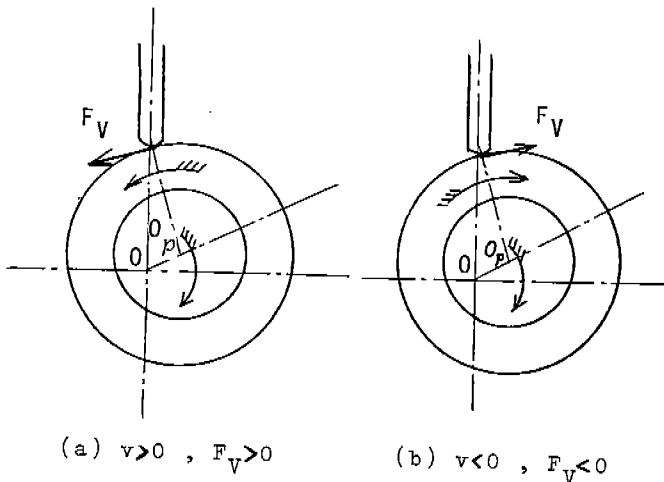

Fig. 4 Two kinds of relative motions between vane and rolling piston

value after the computation of the angular velocity of the rolling piston. The method for the computation of the angular velocity of the rolling piston may be described in the latter chapter.

$$W_V = \frac{\begin{vmatrix} C_1 & -C_1 & D_1' \\ 1 & 1 & D_2' \\ C_4 & C_5 & D_3' \end{vmatrix}}{\begin{vmatrix} C_1 & -C_1 & C_2' \\ 1 & 1 & C_3' \\ C_4 & C_5 & C_6' \end{vmatrix}} \quad (15)$$

Where,

$$\left. \begin{aligned} C_2' &= -\sqrt{1 - \left(\frac{e\cos\theta}{r_o+r_2}\right)^2} \\ C_3' &= \frac{e\cos\theta}{r_o+r_2} \\ C_6' &= C_3'(C_4 - a) \\ D_1' &= D_1 - F_V \cdot C_3' \\ D_2' &= D_2 + F_V \cdot C_2' \\ D_3' &= D_3 + F_V \cdot C_2'(C_4 - a) \end{aligned} \right\} (16)$$

Friction between Rolling Piston and Eccentric

The eccentric and the rolling piston will behave somewhat similar to a journal and a bearing and a similar analysis on journal bearing should be applicable. The bearing loads acting in this case are: (1) pressure load of W_p , (2) contacting force of W_V , (3) tangential force of F_V which is mentioned before, and (4) centrifugal force of F_e . The equivalent angular velocities of journal and bearing are $(\omega_1 - \omega_3)$ and $(\omega_2 - \omega_3)$ respectively, where ω_1 , ω_2 , and ω_3 are the angular velocities of the eccentric, the rolling piston and the concentrated load acting on the eccentric, respectively. The oil film pressure p is given by the following equation.

$$\frac{1}{6\eta} \left[\frac{1}{r^2} \frac{\partial}{\partial \psi} (h^3 \frac{\partial p}{\partial \psi}) + \frac{\partial}{\partial z} (h^3 \frac{\partial p}{\partial z}) \right] = (\omega_1 + \omega_2 - 2\omega_3 - 2\dot{\phi}) \frac{\partial h}{\partial \psi} + 2c\dot{\chi} \cos\psi \quad (17)$$

Referring to the differential equation of (17), the eccentricity χ of the journal, the eccentric angle ϕ and the angle ψ_1 of oil film existence can be obtained by a method of numerical integration, when the bearing load, ω_1 and ω_2 are given as functions of time. Then, the friction torque T_r between the rolling piston and the eccentric is given as follows:

$$T_r = r_1^2 l c \left[-\frac{2\pi\eta U}{c\sqrt{1-\chi^2}} - \frac{3\eta r_1}{c} \left\{ \frac{3\chi^2}{2+\chi^2} (\omega_1 + \omega_2 - 2\omega_3) - 2\dot{\phi} \right\} \int_{\psi_1}^{\psi_1+\pi} \frac{d\psi}{(1+\chi\cos\psi)^2} + \chi(\omega_1 + \omega_2 - 2\omega_3 - 2\dot{\phi}) \right]$$

$$\int_{\psi_1}^{\psi_1+\pi} \frac{\cos\psi}{(1+\chi\cos\psi)^2} d\psi + 2\chi \int_{\psi_1}^{\psi_1+\pi} \frac{\sin\psi}{(1+\chi\cos\psi)^2} d\psi \} \quad (18)$$

Where,

$$U = r_1(\omega_1 - \omega_2) \quad (19)$$

And it is assumed that the half part of the piston-eccentric bearing gap is filled with oil.

Calculation on Angular Velocity of Rolling Piston

The kinetic equation about the center of the rolling piston is represented as follows:

$$r_o F_V + T_R = I \dot{\omega}_2 \quad (20)$$

The solution of equation (20) may be analytically impossible because both variables F_V and T_R are very complicated. So that a method of numerical integration is practically convenient to solve equation (20).

Now assume the ω_2 value be the following ω_o value as an initial value.

$$\omega_o = \omega_1 \left[1 - \frac{R}{r_o} - \frac{e}{r_o} \left\{ 1 + \frac{e}{r_o+r_2} \cos^2\theta - \sin\theta \sqrt{1 - \left(\frac{e\cos\theta}{r_o+r_2} \right)^2} \right\} \right] \quad (21)$$

With this assumption, the relative motion between the rolling piston and the vane is not of sliding but of pure rolling. This kind of state can be continuative when the ratio μ_3 of the tangential force F_V to the contacting force W_V is less than the coefficient of friction μ_2 . However, when the ratio μ_3 grows beyond the coefficient of friction μ_2 , slipping will occur at the vane-piston contacting point.

The F_V values can be obtained by the following numerical calculating method.

- (1) Assuming F_V value to be a constant. Then, the contacting force W_V is calculated by equation (15). Besides, the concentrated load \vec{W}_p acting on the eccentric is evaluated by equations (6) and (7) and the angular velocity ω_3 of \vec{W}_p is computed.
- (2) Calculate the friction torque T_R by equation (18) using the decided angular velocities of ω_1 , ω_2 which is equal to ω_o , and ω_3 .
- (3) The tangential force F_V at the vane-piston contacting point is calculated by substituting the T_R value, which is obtained above, into equation (20).
- (4) If the new obtained F_V value is quite different

to that primarily assumed value, let the new F_V value be the average value of the primarily and the new one. Then continue to the step (1) again.

This flow of calculation is repeated until the difference between the previously obtained value and the new one is considered to be less.

The coefficient μ_3 is calculated by dividing the F_V value, which is obtained above, by the W_V value. It is considered that (1) if μ_3 is less than the coefficient of friction μ_2 , slipping should never occur at the vane-piston contacting point. And then, the angular velocity ω_2 of the rolling piston is represented by equation (21) and (2) if μ_3 is larger than μ_2 , slipping may occur at the vane-piston contacting point. At this state, the angular velocity of rolling piston may be calculated by the following method referring to the kinetic equation (20).

According to the advanced EULER's way of numerical integration, the ω_2 value after a very short time of Δt can be obtained as follows:

$$\begin{aligned} \omega_2(t_1)^1 &= \omega_2(t_o) + \Delta t \dot{\omega}_2(t_o) \\ \omega_2(t_1)^2 &= \omega_2(t_o) + \frac{1}{2}\Delta t \{ \dot{\omega}_2(t_o) + \dot{\omega}_2(t_o)^1 \} \\ &\vdots \\ \omega_2(t_1)^k &= \omega_2(t_o) + \frac{1}{2}\Delta t \{ \dot{\omega}_2(t_o) + \dot{\omega}_2(t_1)^{k-1} \} \end{aligned} \quad (22)$$

Where, $t_1 = t_o + \Delta t$.

EXAMPLE CASES

A typical refrigerating compressor is analysed to demonstrate the applicability of the above analysis. Dimensions of the compressor and operating conditions are shown in Table 1.

Fig. 5 shows some instantaneous positions of the rolling piston with a marked point as the result of calculation using the input-data shown in Table 1. The point sweeps out a trajectory which looks like a trochoid. The trajectory suggests that the rolling piston rotates slowly to the same direction as the eccentric rotates.

Fig. 6 shows abrasive tracks on the cylinder head of a compressor having the same dimensions and operating conditions as shown in Table 1. These tracks are made by hard surface asperities on the rolling piston or by wear debris cut into the clearance between the cylinder head and the rolling piston. The shape of abrasive tracks as shown in Fig. 6 is similar to the analytical trajectory as shown in Fig. 5.

Figs. 7 and 8 show the angular velocity of the rolling piston and the sliding velocity between the vane and the rolling piston, respectively, as

Table 1. DIMENSIONS AND OPERATING CONDITIONS

Symbol		
R	27	mm
r_0	22	mm
r_1	17	mm
r_2	6	mm
a	24	mm
b	5	mm
c	0.011	mm
e	5	mm
L	24	mm
l	14	mm
P_s	0.6	N/mm ²
P_d	2.1	N/mm ²
n	1.1	
η	9×10^{-9}	NS/mm ²
μ_1	0.1	
μ_2	0.1	
ω_1	120π	s ⁻¹

functions of time. Referring to Fig. 8, it is noticed that the relative motion between the vane and the rolling piston is of reciprocating sliding. And the v value is positive between the point a and b which means that the rolling piston rubs the vane-tip from the side of the suction port to the side of the discharge port. Distinct knees at points a and b are found on the curve shown in Fig. 7, which are caused by the change of the vane-piston sliding direction.

This analysis is convenient for predicting the behavior of rolling piston when new dimensions

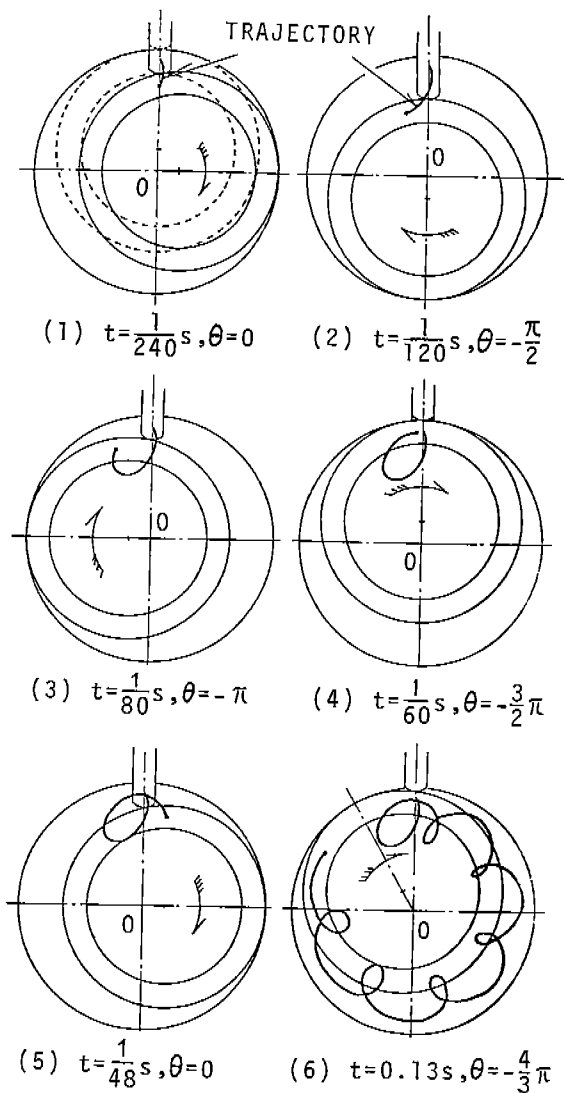

Fig. 5 Trajectory of a point on side surface of rolling piston

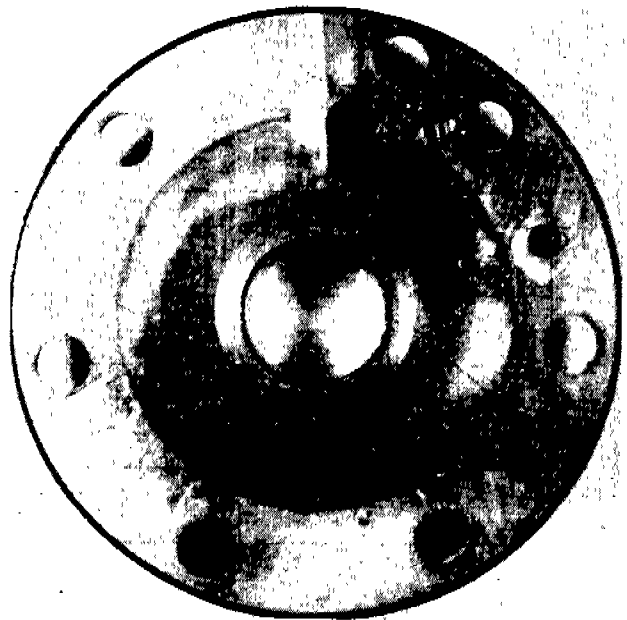

Fig. 6 Abrasive tracks on cylinder head

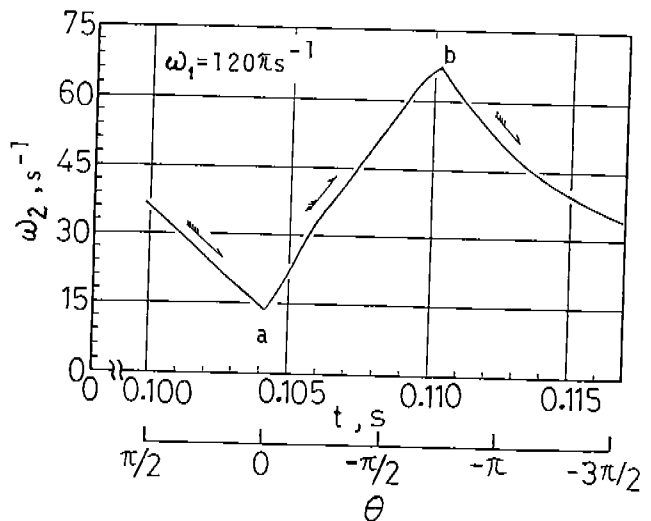

Fig. 7 Angular velocity of rolling piston

of compressor are attempted to be developed. For example, the behavior of rolling pistons of three different types as shown in Fig. 9 is analyzed and the sliding velocities between the vane tip and the rolling piston are calculated as shown in Table 2. Referring to Table 2, type B has the lowest sliding velocity and it is expected that the wear rate of vane tip may be the lowest with type B.

Table 2. CONDITIONS OF CONTACT BETWEEN VANE AND ROLLING PISTON

Type	A	B	C
Maximum Sliding Velocity, m/s	1.1	0.37	1.1
Maximum Contacting Force, N	150	220	85
Friction Loss, W	7.3	1.7	4.5

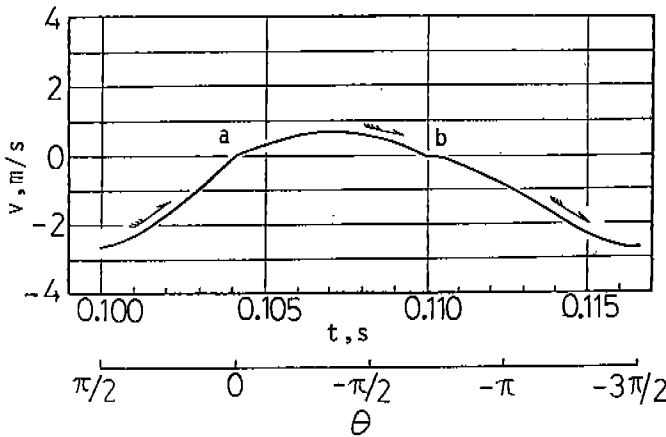

Fig. 8 Sliding velocity between vane and piston

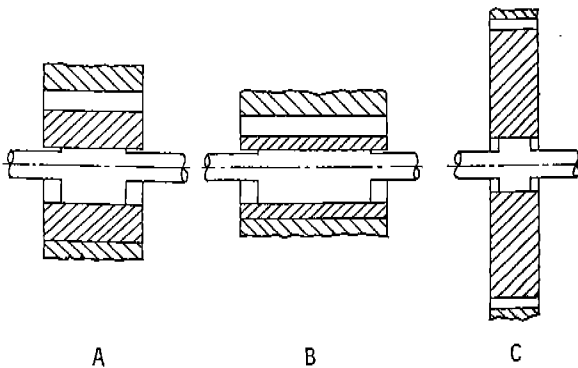

Fig. 9 Cross sections of three example cases

- A : Square piston type
- B : Long piston type
- C : Short piston type

Each of three types has the same volume of compression chamber.

CLOSURE

The behavior of the rolling piston in a rotary compressor has been analyzed and some calculations for examples of refrigeration compressors are demonstrated.

The usefulness of the analytical approach is summarized as follows:

- (1) The behavior of rolling piston can be easily predicted with many kinds of dimensions and operating conditions. At the same time, both the sliding velocities and the contacting forces at all the sliding contacts can be obtained as functions of time.
- (2) Referring to the analyses of many kinds of compressors, appropriate dimensions can be chosen according to the designer's demands.

REFERENCES

- [1] Okada, K. and Kuyama, K., "Analysis on Planetary Motion of the Rolling Piston in a Rotary Compressor", Refrigeration (Japan), 50, 571 (1975), pp.331-337.
- [2] Shimizu, T., "Frictional Loss on Rolling Piston of Air Conditioning Rotary Compressor", Refrigeration, 51, 589 (1976), pp.959-966.
- [3] Pandeya, P. and Soedel, W., "Rolling Piston Type Rotary Compressors with Special Attention to Friction and Leakage", Purdue Compressor Technology Conference (1978), pp.209-218.
- [4] Tanizaki, J., Shimizu, T., and Shiga, T., "Kinematic Analysis of Rolling Piston of Rotary Compressor", Preprint of JSME (Japan), No. 783-2 (1978), pp.120-122.