

Purdue University
Purdue e-Pubs

International Compressor Engineering Conference

School of Mechanical Engineering

1978

Mathematical Model of An Electrodynamic Oscillating Refrigeration Compressor

E. Pollak

F.J. Friedlaender

W. Soedel

R. Cohen

Follow this and additional works at: <https://docs.lib.purdue.edu/icec>

Pollak, E.; Friedlaender, F. J.; Soedel, W.; and Cohen, R., "Mathematical Model of An Electrodynamic Oscillating Refrigeration Compressor" (1978). *International Compressor Engineering Conference*. Paper 273.
<https://docs.lib.purdue.edu/icec/273>

This document has been made available through Purdue e-Pubs, a service of the Purdue University Libraries. Please contact epubs@purdue.edu for additional information.

Complete proceedings may be acquired in print and on CD-ROM directly from the Ray W. Herrick Laboratories at <https://engineering.purdue.edu/Herrick/Events/orderlit.html>

MATHEMATICAL MODEL OF AN ELECTRODYNAMIC OSCILLATING REFRIGERATION COMPRESSOR

Eytan Pollak
Graduate Research Assistant

F. J. Friedlaender
Professor of Electrical Engineering

Werner Soedel
Professor of Mechanical Engineering

Raymond Cohen
Professor of Mechanical Engineering

Ray W. Herrick Laboratories
School of Mechanical Engineering
Purdue University
West Lafayette, Indiana 47907

INTRODUCTION

This paper shows a mathematical simulation model for a one cylinder electrodynamic compressor as shown schematically in Figure 1. This compressor is commonly known as a Doelz compressor. The coil is suspended by two springs and the piston is connected to the coil. The driving force comes from the interaction of the current in the coil with a steady magnetic field which is produced by a permanent magnet. When the coil is connected to an alternating voltage source, the piston and the coil will curve at the input frequency.

There has always been interest in oscillating compressors because the kinematics are so uncomplicated, which seems to make these compressors candidates for low cost designs, and a variety of oscillating compressors, not always on identified principles, has been invented through the years and analyzed.

The analysis that comes closest to the work described here is that by Cadman and Cohen [1,2]. However, their compressor was a two piston double acting unit that did not have certain difficulties that had to be faced in this simulation. For instance, as will be explained, the present case has a floating operating point that is a function of the pressure ratio. This introduces the difficulty that the compressor will reduce its pumping of gas as the pressure ratio increases, much more so than a conventional compressor.

The only other investigation that has to be mentioned is that by Funer [3,4], which is, however, experimental and not concerned with a simulation.

Other papers about oscillating compressors that may be of interest are given in references [5-10].

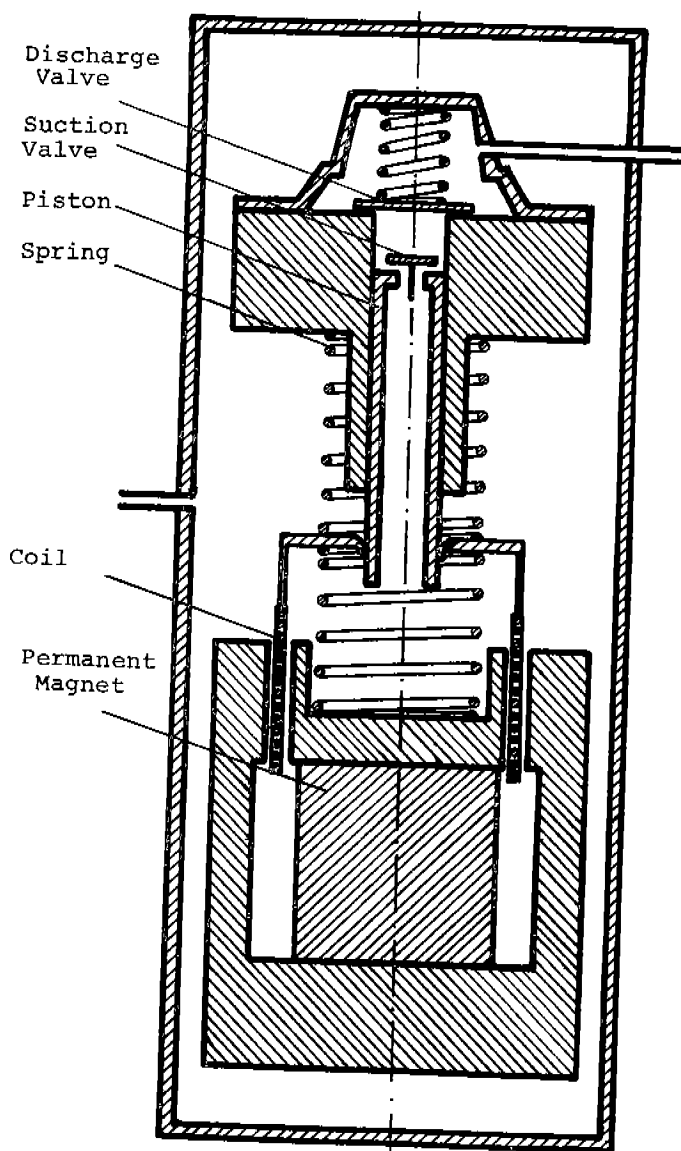

Figure 1. Schematic Drawing of an Oscillating Compressor.

BASIC MATHEMATICAL MODEL

The development of the model starts with a free body diagram of the piston as shown in Figure 2. Acting on the piston is the force due to the combined springs, including the gas effects, and the electrodynamic driving force. The mass of the piston includes a portion of the spring mass and, of course, the driving coil mass. Very important is the fact that at every oscillation energy is removed from the system equal to the work of gas compression and the work that is necessary to overcome piston friction.

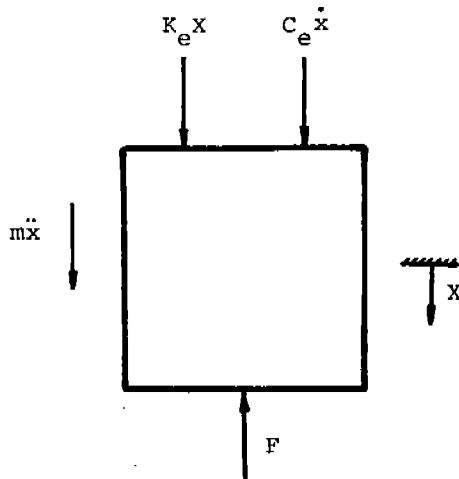

Figure 2. Free Body Diagram.

These various terms are treated in the following, but at present they are lumped together in terms of an equivalent spring constant k_e , an equivalent viscous damping constant c_e and an equivalent mass m_e . The equation of motion that governs the mechanical part of the system is, therefore, given by:

$$m_e \frac{d^2x}{dt^2} + c_e \frac{dx}{dt} + k_e x = F \quad (1)$$

where

$$F = B_e l_e i$$

and where B_e is the effective magnetic flux in $\left[\frac{\text{Web}}{\text{m}^2}\right]$ that is available to act on the coil, l_e is the effective length of coil wire in [m]. The current i in [Amp] is obtained from an electric system equation. The electric circuit can be thought of as consisting of an effective resistance R_e in $[\Omega]$, an effective inductance L_e in [Hz], an effective back electro-magnetic voltage $B_e l_e \dot{x}$ in [V] and a voltage source of constant magnitude V in [V]. This circuit is shown in Figure 3. The circuit equation is:

$$B_e l_e \frac{dx}{dt} + R_e i + L_e \frac{di}{dt} = V \quad (2)$$

These equations can now be solved provided we know what the equivalent parameters are. The definition of the equivalent parameters follows.

Equivalent Damping C_e

Damping in the oscillating compressor can be viewed to come about in three ways. The most important is the work done by the compressor on the gas, which is equal to the area enclosed by an ideal pressure volume diagram. To this the valve losses are added. The final important loss to the vibratory system that has to be described by equivalent damping is the friction loss.

The basic approach to formulate an equivalent damping coefficient is well known [11]. The energy dissipated per cycle E of a harmonically oscillating system is:

$$E = C_e \omega X_0^2 \quad (3)$$

where ω is the frequency of oscillation in [rad/sec] and X_0 is the amplitude of oscillation. From this we get:

$$C_e = \frac{E}{\pi \omega X_0^2} \quad (4)$$

In general, we have

$$E = W + E_v + E_f \quad (5)$$

where W is the work done on the gas and is described by a pressure volume diagram with ideal valves. E_v is the energy dissipated by the valves and E_f is the energy dissipated by system friction.

Note that the concept of equivalent damping depends on the requirement that the system oscillations are at least approximately harmonic. Theoretically, this assumption is justified since the parameters for this type of compressor are such that the system oscillation is controlled by the mechanical springs, which are of course linear. A relatively small nonlinearity is introduced by the gas spring effect, but this is a second order effect when one compares the various spring constants. Experimental work by Funer [3,4] seems to indicate the same, even which he does not report are actual measurement of the entire piston motion. In this work, the authors did measure the voltage and current time history and found both to be sinusoidal for all practical purposes. If the piston motion would have deviated appreciably from harmonic motion, this should have been reflected in the current measurement.

The manufacturer's patent [12] indicated an approximately sinusoidal motion, but it is not known if this based on actual measurements.

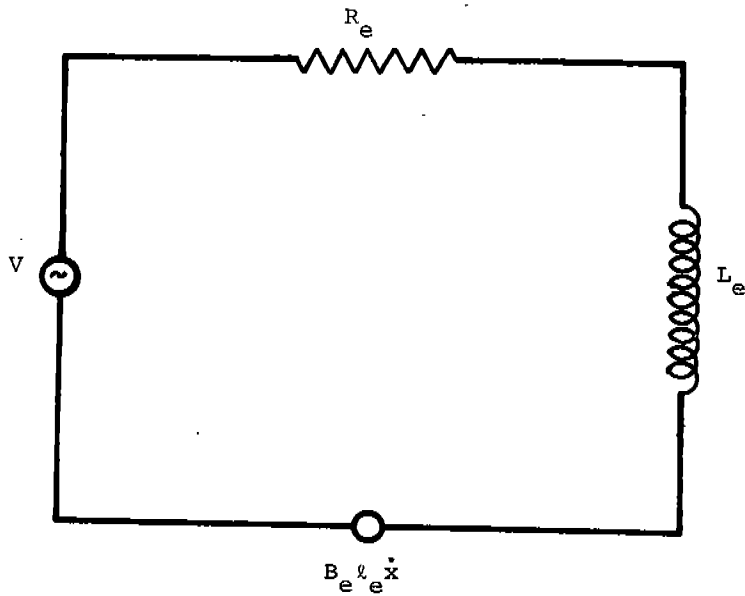

Figure 3. Electric Circuit of the Oscillating Compressor.

1. Work Done on Gas

From basic thermodynamics, we obtain for a typical ideal pressure volume diagram, as shown in Figure 4, the work per cycle as:

$$W = \frac{n}{n-1} p_s V_s \left[\left(\frac{p_d}{p_s} \right)^{(n-1)/n} - 1 \right] \quad (6)$$

where nominal p_s is the suction pressure in $[N/m^2]$ and V_s is the effective intake volume.

It is necessary to express everything in terms of the as yet unknown vibration amplitude X_0 . In order to do this, we have to refer again to Figure 4. The intake volume can then be found as:

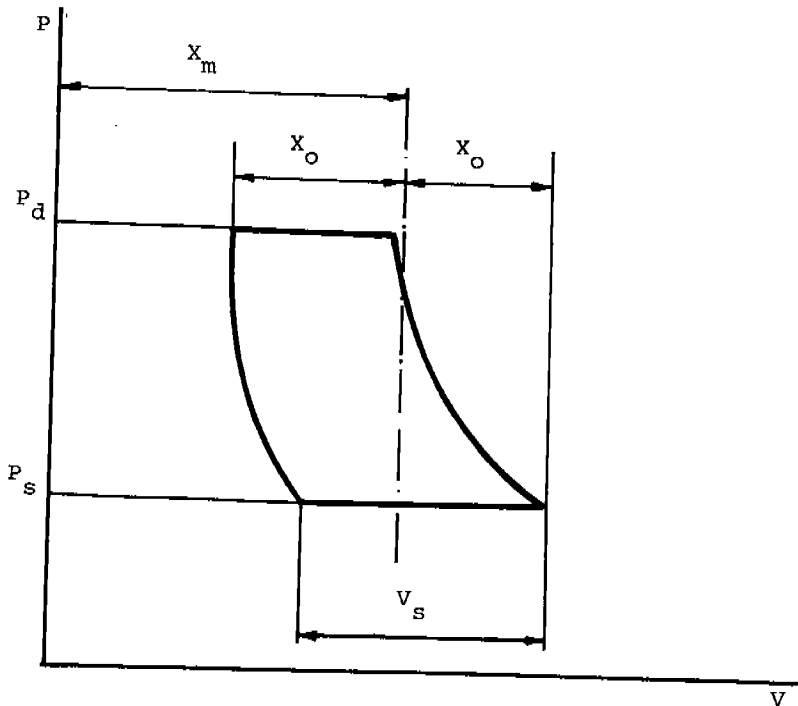

Figure 4. Pressure Volume Diagram

$$V_s = \left\{ \left[1 + \left(\frac{p_d}{p_s} \right)^{\frac{1}{n}} \right] X_o + \left[1 - \left(\frac{p_d}{p_s} \right)^{\frac{1}{n}} \right] X_m \right\} A_p \quad (7)$$

Where A_p is the piston area in $[m^2]$ measured from the top of the cylinder around which the piston is oscillating. Note that X_m will be a function of the preset piston position Z_o when no forces are acting on the piston (see Figure 5) and a bias position Y_o which is a function of the pressure ratio, given by:

$$Y_o = \frac{(p_d - p_s) A_p}{2 (k_1 + k_2)}$$

Note that k_1 and k_2 are the two mechanical spring constants in $[N/m]$.

In general, the work can be written as:

$$W = C_1 X_o + C_2 X_m \quad (8)$$

where

$$C_1 = \frac{n}{n-1} p_s \left[\left(\frac{p_d}{p_s} \right)^{(n-1)/n} - 1 \right] \left[1 + \left(\frac{p_d}{p_s} \right)^{1/n} \right] A_p$$

$$C_2 = \frac{n}{n-1} p_s \left[\left(\frac{p_d}{p_s} \right)^{(n-1)/n} - 1 \right] \left[1 - \left(\frac{p_d}{p_s} \right)^{1/n} \right] A_p$$

Note that for some operating conditions it is possible for the piston to push the

discharge valve out of the way. It is, of course, not possible for the p-V diagram to extend into the negative volume region. The work expression must therefore be modified. The best approximation seems to be to approximate the work expression as:

$$W = \frac{b}{a} (C_1 X_o + C_2 X_m) \quad (9)$$

where Figure 6 defines b and a . The figure shows the work done if the displacing of the valve is ignored. It also shows what happens in reality, namely that once the valve is displaced, no further compression takes place. Because of the valve dynamics, there will be backflow which acts like a re-expansion of gas. How the re-expansion actually looks like depends on many factors, but it is felt that what is covered here is a reasonable approximation.

2. Valve Losses

To find the valve losses in the oscillating compressor we assume that the total energy of the gas is converted into the pressure difference across the valve.

From the Bernoulli equation we can write a general expression for the average

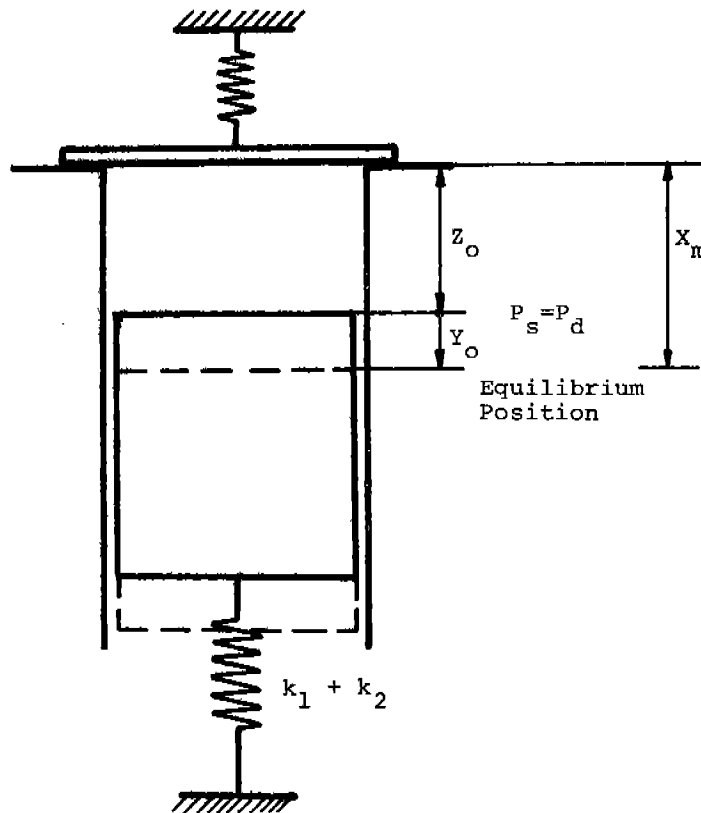

Figure 5. Equivalent System

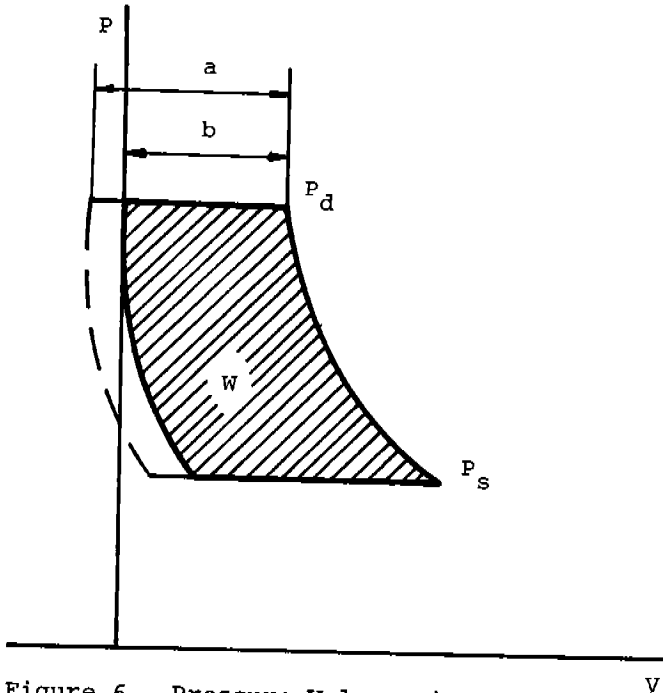

Figure 6. Pressure Volume Diagram for Piston Pushing the Discharge Valve.

pressure drop at the valve as follows:

$$\Delta p = \frac{\rho v^2}{2} \quad (10)$$

where

ρ = density of the gas [$\frac{\text{kg}}{\text{m}^3}$]

v = average velocity of the gas [$\frac{\text{m}}{\text{sec}}$]

The average velocity of the gas flowing through the valve can be expressed as:

$$v = \frac{V}{\Delta t A} \quad (11)$$

where

V = volume of the gas [m^3] being discharged or taken in.

Δt = opening time of the valve [sec]

A = average effective cross actual area of the valve port [m^2]

Then we can rewrite equation (10) using equation (11) as:

$$\Delta P = \frac{\rho V^2}{2 \Delta t^2 A^2} \quad (12)$$

from which the energy lost in the valve per cycle can be expressed as:

$$E = \Delta p \cdot V$$

or finally:

$$E = \frac{\rho V^3}{2 \Delta t^2 A^2} \quad (14)$$

To obtain the total valve loss, we have to add the loss for the discharge valve, E_d , and the loss for the suction valve, E_s .

$$E_v = \frac{\rho_s V_s^3}{2 \Delta t_s^2 A_s^2} + \frac{\rho_d V_d^3}{2 \Delta t_d^2 A_d^2} \quad (14a)$$

The opening time is obtained from the p-v diagram and the fact that the oscillation is sinusoidal.

3. Friction Loss

In order to find the energy dissipated by the friction generated by the stress in the oil between the piston and the cylinder wall we need to solve the Navier-Stokes equation for incompressible flow [15].

Referring to Figure 7 we see immediately that various simplifications are possible. Assuming that the oil film is always of constant thickness around the piston, the equations simplify to:

$$-\frac{1}{\rho} \frac{\partial p}{\partial \xi} + \frac{\mu}{\rho} \frac{\partial^2 u}{\partial z^2} = 0 \quad (15)$$

When u is the flow velocity in [m/sec], p is the pressure in the oil film in [N/m^2], μ is the viscosity of the oil [Nsec/m^2] and ρ is the mass density of the oil in [Nm^2/m^4].

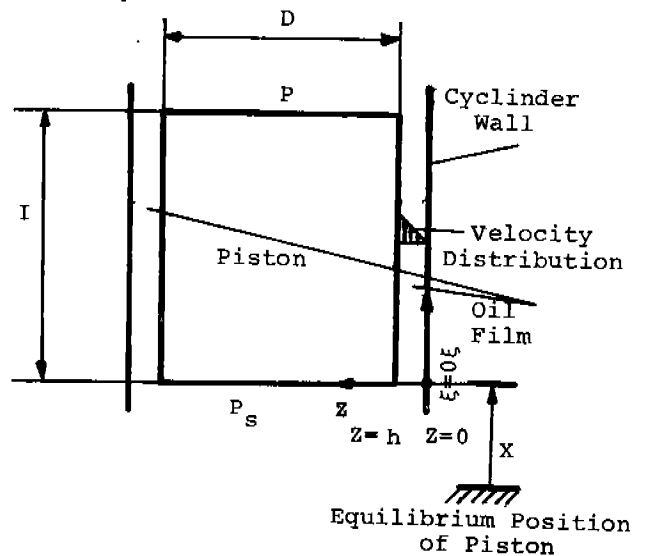

Figure 7. Analysis of the Oil Film

Integrating this equation gives:

$$\frac{d_p}{d\xi} \frac{z^2}{2} = \mu u + A_1 z + A_2 \quad (16)$$

Since at $z = 0$, $u = 0$, but at $z = h$, the flow velocity, u , must be equal to the

piston velocity \dot{x} , we obtain, after evaluations of the integration constants,

$$u = \frac{\dot{x}z}{h} - \frac{hz}{2\mu} \frac{dp}{d\xi} \left(1 - \frac{z}{h}\right) \quad (17)$$

Since the shear stress is:

$$\tau_{xz} = \mu \frac{\partial u}{\partial z} \quad (18)$$

and since we may assume that:

$$\frac{dp}{d\xi} = \frac{p - p_s}{H} \quad (19)$$

where H is the height of the pistons, we get, at $z = a$.

$$\tau_{xz} (z=h) = \frac{\mu \dot{x}}{h} + \frac{h(p - p_s)}{2H} \quad (20)$$

From this we obtain the total force resisting piston motion as:

$$F = B_1 \dot{x} + B_2 \quad (21)$$

where

$$B_1 = \frac{\pi D H \mu}{h}$$

$$B_2 = \frac{\pi D h (p - p_s)}{2}$$

However, when we determine the energy over one cycle of oscillation, the influence of the pressure differential becomes negligible and we obtain:

$$E_f = \frac{\pi^2 D H \mu \omega}{h} x_o^2 \quad (22)$$

Equivalent Spring Constants and Mass

The equivalent spring constant includes the two mechanical springs and the equivalent gas spring constant,

$$k_e = k_1 + k_2 + k_g \quad (23)$$

As we can see from Figure 8, the equivalent spring gas constant can be approximated by, following Cadman [1] in the basic idea, as:

$$k_g = \frac{(p_D - p_s) A_p}{2X_o}$$

However, there is a basic difference to Cadman's work since for this type of oscillating compressor the compressor may not pump but still vibrate between points A and B as shown in Figure 9 and then the spring gas constant can be calculated by the following expression:

$$k_g = \frac{p_s A_p \left\{ \left(\frac{X_m + X_\ell}{X_m - X_\ell} \right)^n - 1 \right\}}{2X_\ell} \quad (25)$$

where X_ℓ is the minimum displacement when the compressor is still pumping, given by:

$$X_\ell = \frac{\{ (P_D/P_S)^{1/n} - 1 \} X_m}{1 + (P_D/P_S)^{1/n}} \quad (25 a)$$

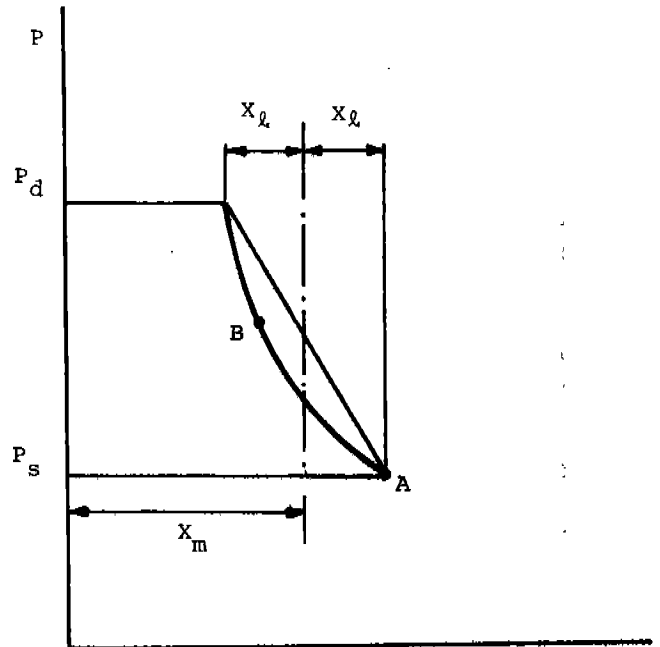

Figure 9. Gas Spring Constant When The Compressor is not pump.

The equivalent mass is simply the mass of the piston, coil plus attachments, with one third of the mechanical spring masses added. The derivation of the one third of spring mass rule is standard form in vibration textbooks [11].

ELECTRICAL MODELING

Despite the fact that the exact analysis of the eddy current and the hysteresis losses are very complicated for the oscillating motor, we can find in the literature [13] that for modeling purposes we can use an equivalent resistance parallel to the coil inductance as shown in Figure 10.

The numerical value for this equivalent resistance will be taken as an average constant resulting from tests done on the oscillating motor [14].

Therefore, from Figure 10, we can write an expression for the total equivalent

series impedance of the circuit in Figure 3 as follows

$$Z_t = R + \frac{\omega^2 L^2 R_L}{R_L^2 + \omega^2 L^2} + j \left(\frac{R_L^2 \omega L}{R_L^2 + \omega^2 L^2} \right) \quad (26)$$

R = coil resistance
 L = coil inductance
 R_L = equivalent
 for iron loss

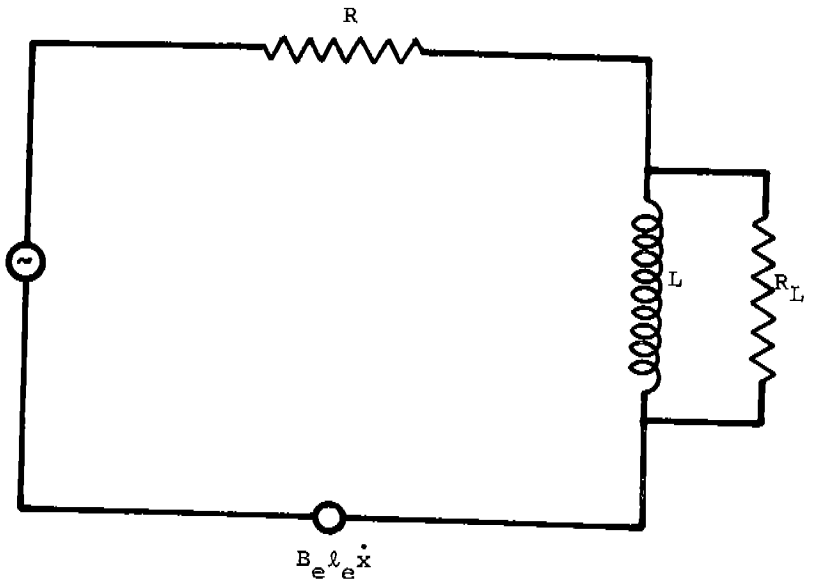

Figure 10. Electric Circuit Modeling the Iron Losses

or, by representing the circuit by an equivalent resistance and equivalent inductance, we get:

$$R_e = R + \frac{\omega^2 L^2 R_L}{R_L^2 + \omega^2 L^2} \quad (27)$$

and

$$L_e = \frac{R_L^2 L}{R_L^2 + \omega^2 L^2} \quad (28)$$

Note that an impedance is a steady state concept based on harmonically varying voltage and current. Since the model of the oscillating compressor is a steady state model based on a harmonic motion assumption and harmonic voltage and current, the impedance expressions are compatible with the model. However, if a transient analysis of, for instance, the start up conditions, is attempted, a careful reappraisal of this method is needed

SOLUTION APPROACH

Describing the input voltage, the current and the displacement as sinusoidal functions we can write, by complex notation, the voltage as:

$$v = V_0 e^{j\omega t} \quad (29)$$

the current

$$i = I_0 e^{j(\omega t - \alpha)} \quad (30)$$

and the displacement

$$x = X_0 e^{j(\omega t - \beta)} \quad (31)$$

The sinusoidal functions for the current and the displacement can be justified by the fact that the system is controlled by the two mechanical springs. Voltage and current were actually measured on the operating compressor prototype and were found to be sinusoidal for all practical purposes. However, in systems where the piston is controlled by the gas (for example, the free piston compressor) this assumption may have to be modified because then the nonlinear effect of the gas compression may influence strongly the behavior of the system.

Substituting these sinusoidal solution functions into Equations 1 and 3, we find the displacement amplitude to be:

$$X_0 = \frac{(V_0 B_e \ell_e)^2}{\Delta^2} \quad (32)$$

and the current amplitude:

$$I_0 = \frac{[(K_e - m\omega^2)^2 + (C_e \omega)^2] V_0^2}{\Delta^2} \quad (33)$$

where

$$\Delta^2 = \Delta_1^2 + \Delta_2^2$$

and

$$\Delta_1 = K_e R_{eq} - m\omega^2 R_e - C_e \omega^2 L$$

$$\Delta_2 = B_e \ell_e \omega + L K_e \omega - m\omega^3 L_e + C_e \omega R$$

and the phase of the displacement and the current are as follows:

$$\beta = \tan^{-1} \frac{\Delta_2}{\Delta_1} - \frac{\pi}{2} \quad (34)$$

and

$$\alpha = \tan^{-1} \frac{\Delta_2}{\Delta_1} - \tan^{-1} \frac{C_e \omega}{k_e - m\omega^2} \quad (35)$$

It must be noted that the equivalent damping and the equivalent spring are functions of the displacement and therefore equation (32) is nonlinear. An iteration process has to be used to calculate the displacement.

A flow diagram of the oscillating compressor simulation program is shown in Figure 11. In the following paragraph the consecutive steps taken by the computer are briefly explained.

First, input parameters are defined which include, basically, two groups of parameters; 1) the operation conditions (pressure ratio, frequency, etc., 2) design parameters (mass, resistance, spring constant, etc.). Next, a value for steady state amplitude X_0 is assumed and the equivalent spring constant and equivalent damping constant are calculated. At this point, the program calculates the piston amplitude by equation (32). If this value is not equal to the initial estimate, the algorithm returns with the new amplitude value to calculate again the equivalent spring constant and the equivalent damping constant.

If the new estimate of the piston amplitude is greater than the mean distance value, then the gas power is calculated by equation (9) and the algorithm starts from the beginning.

If the new value is equal to the previous one, the iteration procedure is terminated. Then the current amplitude and all other information is calculated and printed out (input and output work, losses, efficiency, etc.).

Experimental Investigation

The oscillating compressor was part of a small refrigerating system that included a condenser, evaporator, and a hand regulated expansion valve.

A wattmeter, an ammeter and a voltmeter were used to measure the input power, the current and the voltage input.

Also a voltage regulator and a frequency changer were connected to the compressor.

When the frequency was changed the voltage regulator was adjusted to hold the input voltage constant.

Two thermocouples and two pressure gages were connected to the inlet and outlet of the compressor to measure the pressures and temperatures of the suction and discharge lines.

Operating conditions were changed by changing air flow over the condenser and by adjusting the expansion valve.

Besides measuring wave forms, the purpose of the experimental set up was to obtain measured input power as a function of frequency and operating conditions.

Results and Discussion

For the compressor under investigation, the agreement between theoretical input power and actual input power as functions of frequency, for a given operating condition, is shown in Figure 12. Because of the simplicity of the experimental arrangement, it was difficult to hold the suction and discharge pressures exactly constant, but the scatter as reflected in the experimental points is small.

As we see, the most favorable conditions exist in a very narrow frequency band. Note that the optimum line frequency would be 53 Hz for this particular operating condition. The optimum frequency is a function of both suction and discharge pressure. Figure 13 illustrates this.

In Figure 14, we show the piston amplitude as a function of frequency. In this particular case, the maximum amplitude seems close to the optimum frequency, however, under different conditions and losses, it shifts more to the right of the optimum frequency.

The mass flow as a function of frequency is plotted in Figure 15. As expected, the maximum mass flow occurs at the frequency of maximum amplitude of motion.

Typically, compressors of this type will have reduced mass flow rates with an increase of pressure ratio until there is a pressure ratio where no pumping is possible. This is illustrated in Figure 16 for a pressure ratio of 5.4. This plot agrees in character with the experimental results given by Funer [3] for air, except that Funer plotted delivered volume as a function of pressure ratio.

It is interesting, how the theoretical efficiency changes as we remove the friction loss. This is shown in Figure 17. The theoretical improvement is dramatic at the optimum frequency and indicates one

direction which should be investigated further. Of course, if the line frequency is different, the potential improvement is much reduced.

Figure 18 shows a plot of efficiency as a function of pressure ratio for constant discharge pressure. There seems to be an optimum, for this particular design, at a pressure ratio of about 2.1. This

agrees to some extent with experimental values obtained by Funer [3] on the same compressor, but different line frequency and voltage. Also, he used air and it is not known at which value he kept either the suction or the discharge pressure.

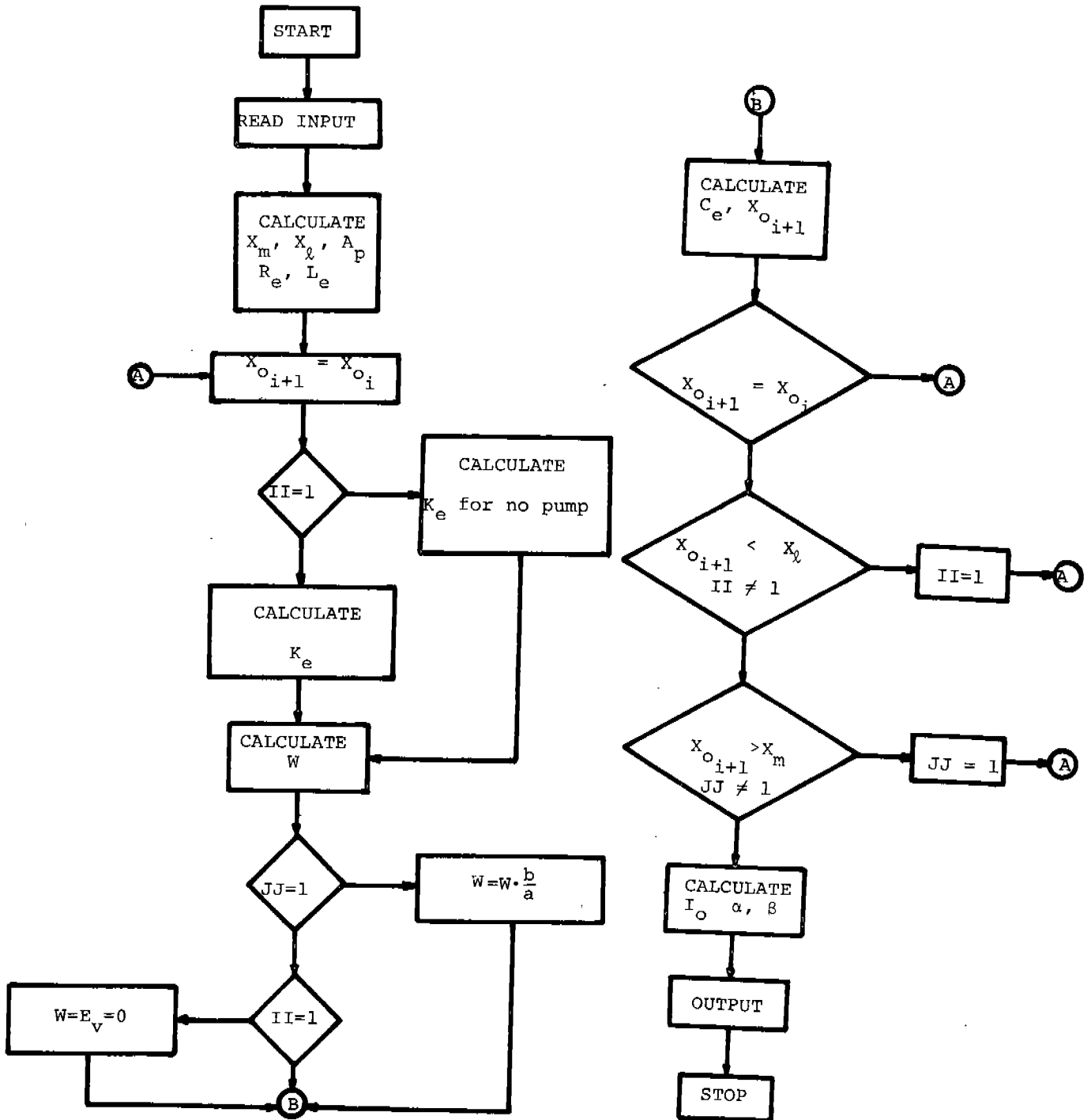

Figure 11. Flow Diagram

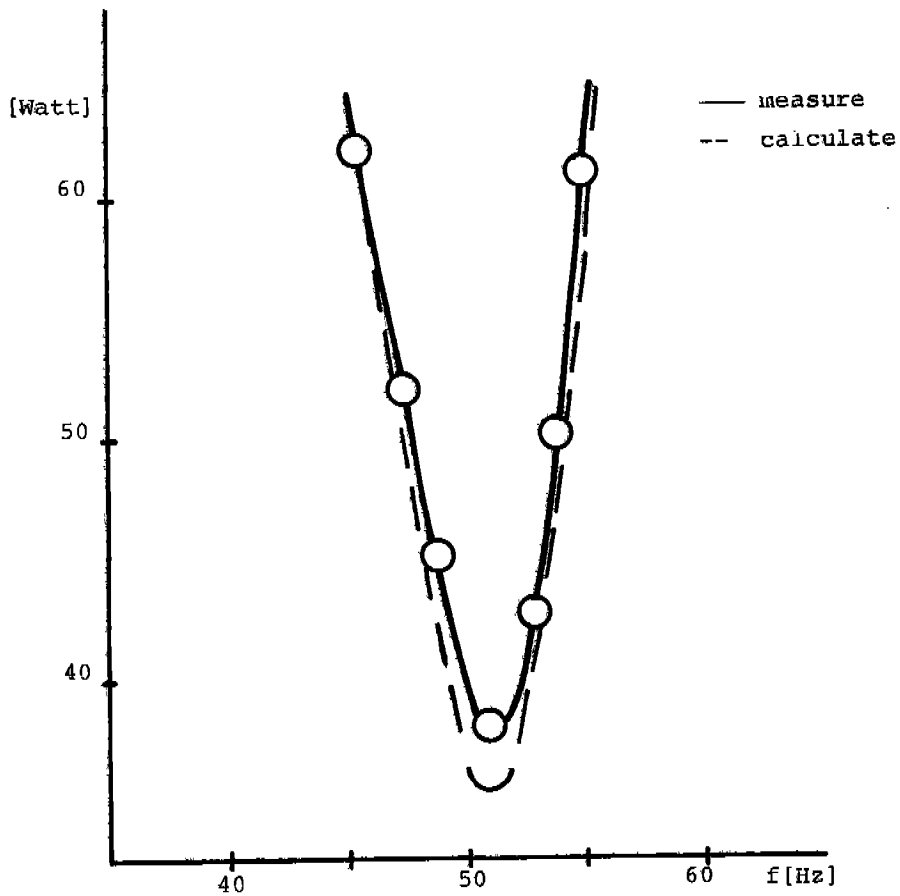

Figure 12. Input Power as a Function of the Frequency

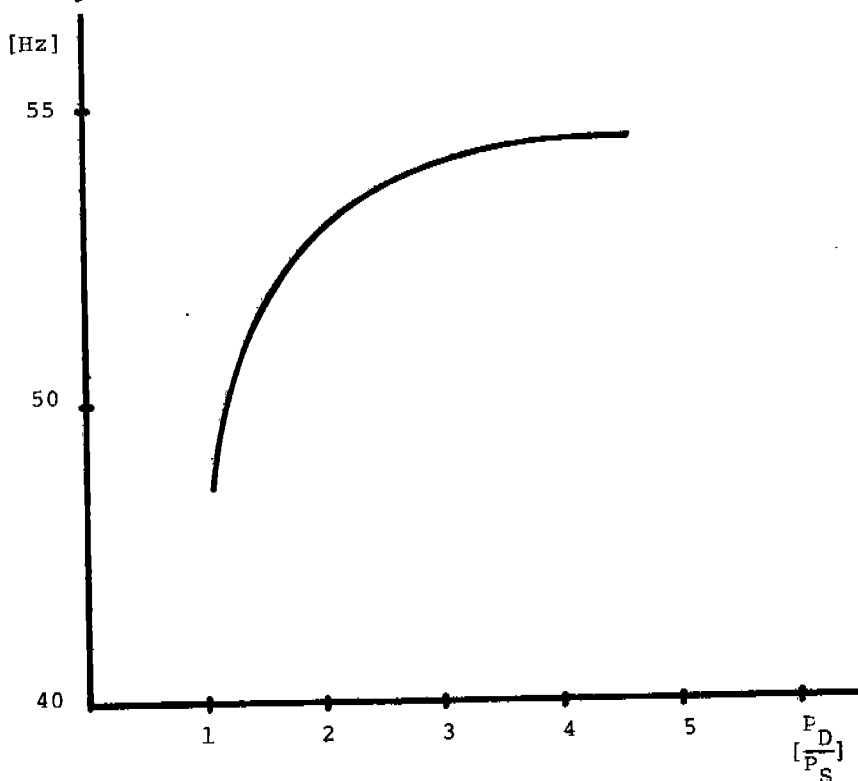

Figure 13. Optimum Frequency as a Function of the Pressure Ratio

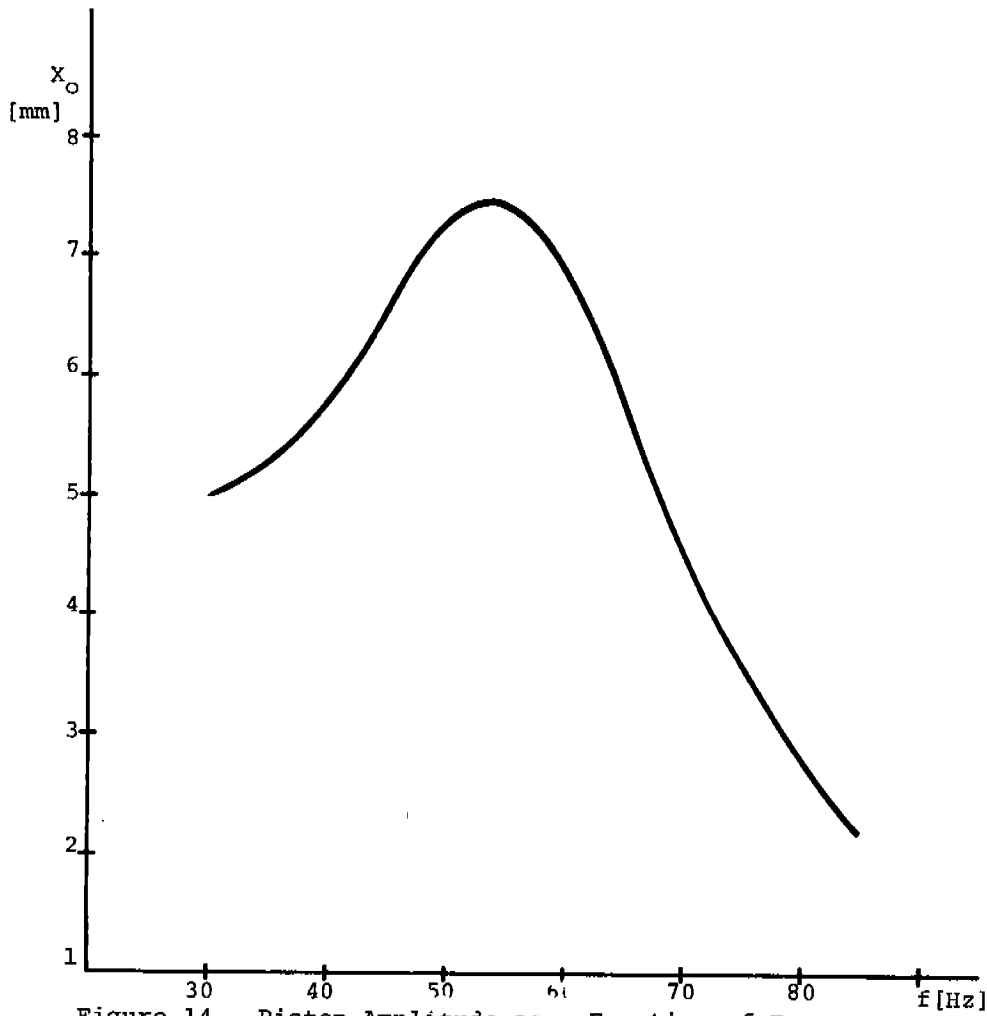

Figure 14. Piston Amplitude as a Function of Frequency

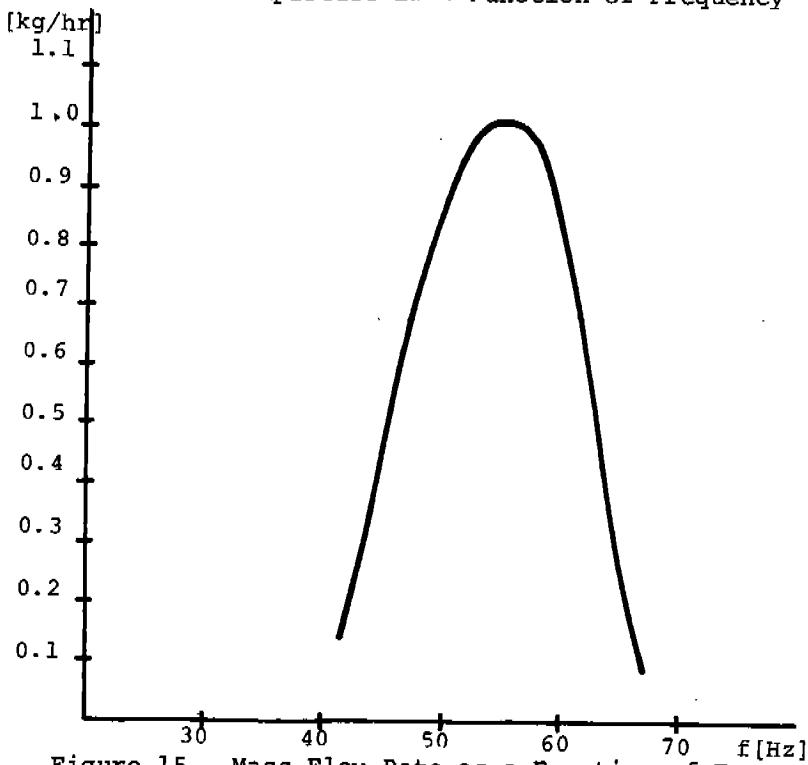

Figure 15. Mass Flow Rate as a Function of Frequency

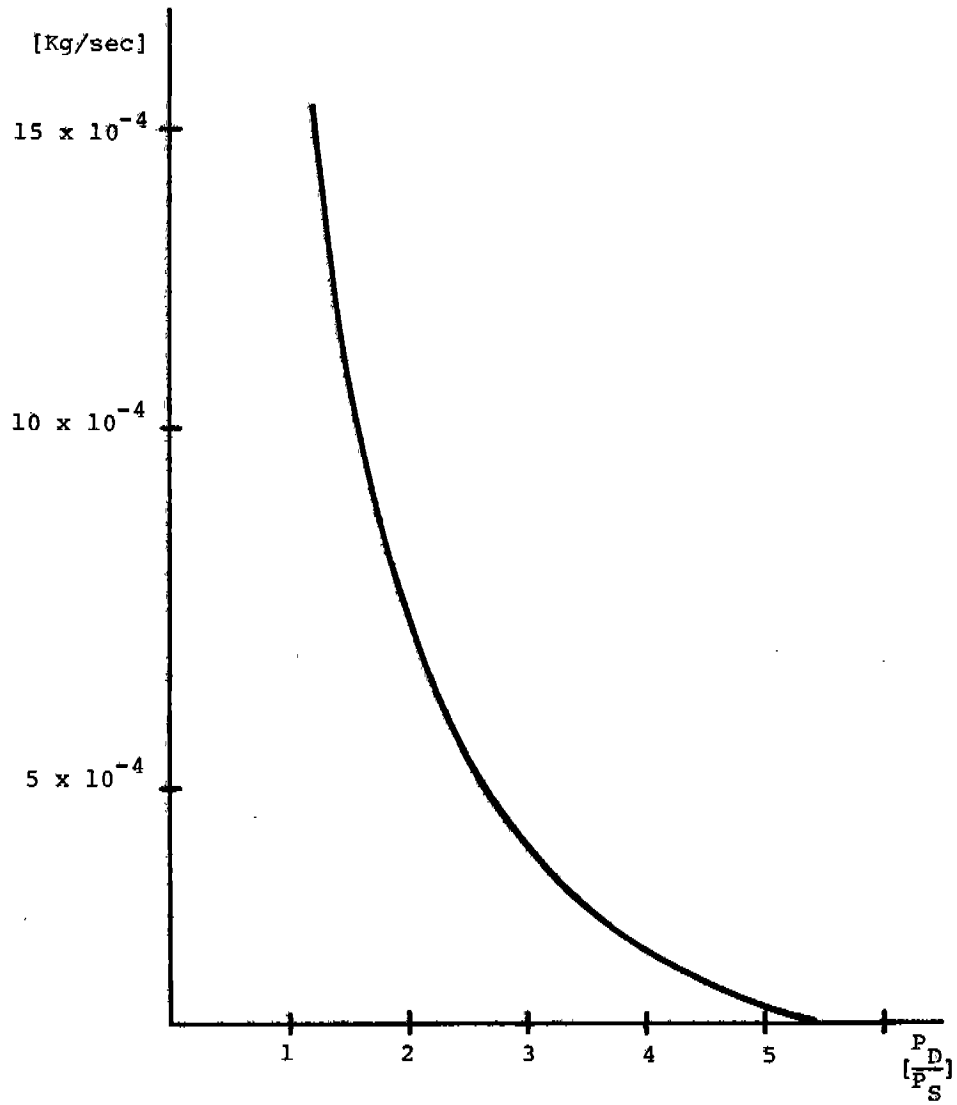

Figure 16. Mass Flow Rate as a Function of Pressure Ratio

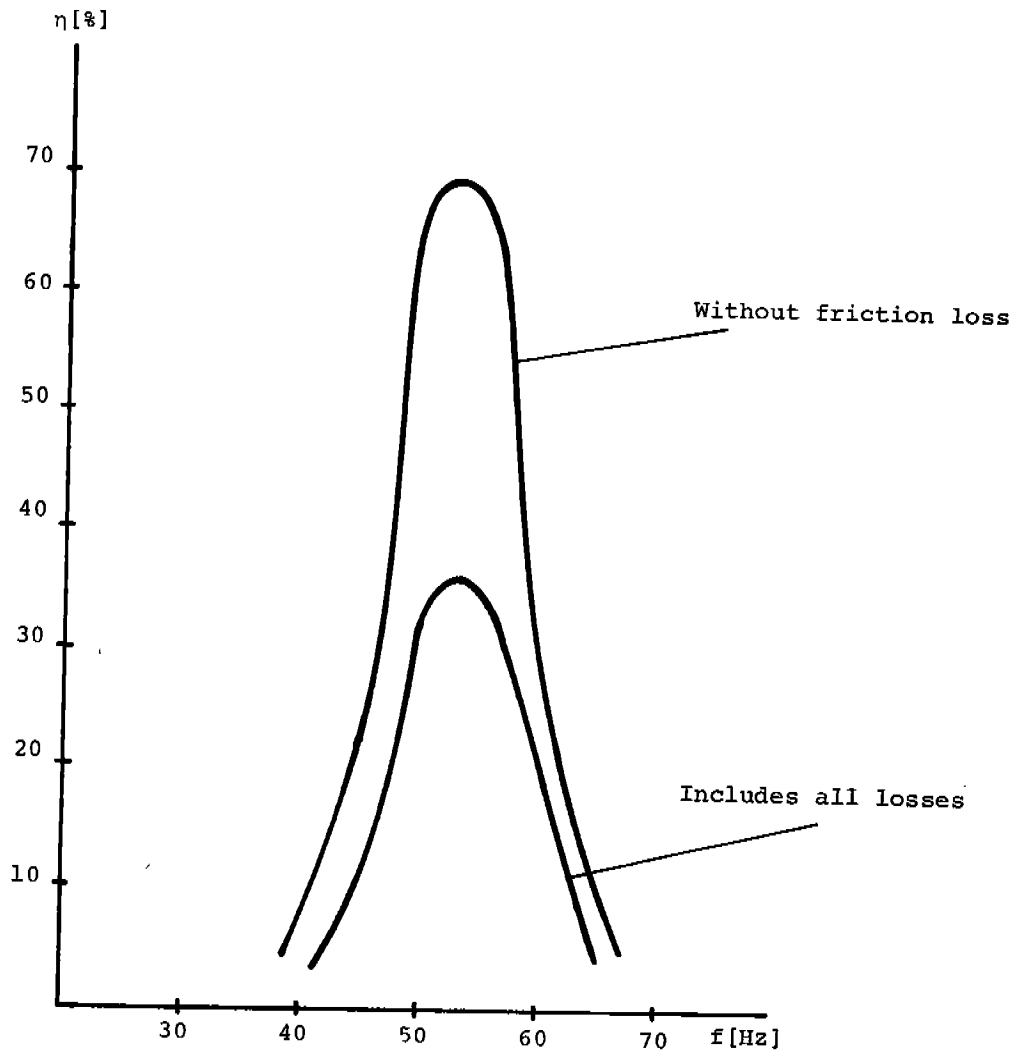

Figure 17. Efficiency as a Function of Frequency

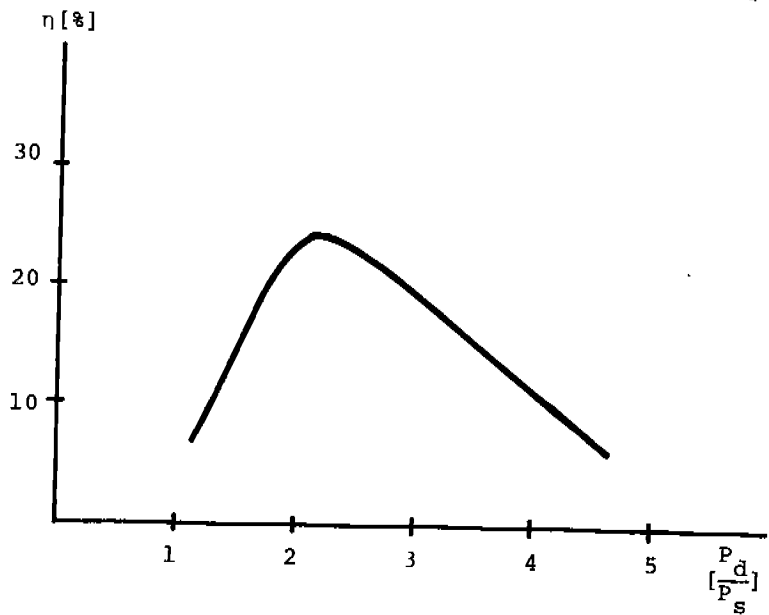

Figure 18. Efficiency as a Function of Pressure Ratio

Conclusion

The following conclusions can be made:

1. The mathematical model that was developed explains certain characteristics of the oscillating electrodynamic compressor. As they were observed through experimental investigations.
2. It is shown that the model can be made to agree with experimentally obtained input power measurements.
3. The efficiency of the system is very sensitive to driving frequency.
4. The compressor is very sensitive to pressure ratio as far as mass flow rate is concerned.
5. For a given design, there seems to be an optimum pressure ratio for maximum efficiency.
6. Just because site forces on the piston are not present does not mean that viscous friction losses between piston and cylinderwall can be neglected. The efficiency at the optimum frequency was shown to be very sensitive to friction loss.
7. The way of modeling the iron losses by an equivalent circuit seems to be reasonable.

References

1. Cadman, R. V., and Cohen, R. "Electrodynamic Oscillating Compressors: Part 1 - Design Based on Linearized Loads", Transactions of the ASME, 1969
2. Cadman, R. V., and Cohen, R. "Electrodynamic Oscillating Compressor: Part 2 - Evaluation of Specific Designs for Gas Loads", Transactions of the ASME, 1969
3. Fuener, V., Tauchmann, R., Schoberl, E., John, R., and Back, K., "Elektronisches Indizieren von Hermetischen Schwingverdichtern" ("Electronical Indication of Hermetic Oscillating Compressors"), Kaeltechnik, Vol. 13, No. 4, April, 1961, pp. 141-149.
4. Fuener, V., John, R., and Tauchmann, R., "Elektronisches Indizieren von Hermetischen Schwingkompressoren" ("Electronic Indication of Hermetic Oscillating Compressors"), Kaeltechnik, Vol. 17, No. 10, October, 1965, pp. 317-322.
5. Schmidt, Th. E., "Schwingverdichter in Kaeltemaschinen" ("Oscillating Compressor in Refrigerations"), Kaeltechnik,

Vol. 8, No. 3, March, 1956, pp. 93-99.

6. Bach, K., "Schwingverdichter" ("Oscillating Compressors"), Kaeltechnik, Vol. 11, No. 8, August, 1959, pp. 262-267.
7. Coates, D. A., and Cohen, R., "Preliminary Study of Free Piston Stability in Electrodynamic Gas Compressor", proceedings of XII International Congress of Refrigeration, Vol. II, pp. 903-914, 1967.
8. Carwen, D. W., "Recent Developments of Oil Free Linear Motor Resonant-Piston Compressors", presented at the Fluids Engineering-Applied Mechanics Conference, Chicago, Illinois, June 16-18, 1968.
9. Yang, Wen-Jei, and Huang, Hung-Sen, "Dynamic Characteristics of Electro-magnetic Compressors", presented at the ASME Winter Annual Meeting, November 16, 1969.
10. Anon., "An Experimental Oscillating Compressor", Journal of Refrigeration, (London), Vol. 7, No. 2, March/April, 1964, p. 33.
11. Thomson, W.T., "Theory of Vibration", Prentice-Hall, 1972.
12. Omura, M., Okuda, Y., Kainuma, H., "Electrical Vibration Type Compressor", U. S. Patent No. 4,027,211, 1977.
13. Slemon, G. R., "Magnetolectric Devices," John Wiley and Sons, Inc., New York, 1966.
14. E. E. Staff M.I.T., "Magnetic Circuits and Transformers," John Wiley and Sons, Inc. New York, 1955.
15. Daily, J. W., Harleman, D. R. F., "Fluid Dynamics," Addison Wesley Publishing Company, Inc., June 1973.