

Purdue University
Purdue e-Pubs

International Refrigeration and Air Conditioning
Conference

School of Mechanical Engineering

2004

Numerical Stimulation of Complex Thermal Systems Involving Multiple Fin-And-Tube Heat Exchangers

Carles Oliet

Universitat Politècnica de Catalunya

Carlos D. Perez Segarra

Universitat Politècnica de Catalunya

Assensi Oliva

Universitat Politècnica de Catalunya

Follow this and additional works at: <http://docs.lib.purdue.edu/iracc>

Oliet, Carles; Segarra, Carlos D. Perez; and Oliva, Assensi, "Numerical Stimulation of Complex Thermal Systems Involving Multiple Fin-And-Tube Heat Exchangers" (2004). *International Refrigeration and Air Conditioning Conference*. Paper 670.
<http://docs.lib.purdue.edu/iracc/670>

This document has been made available through Purdue e-Pubs, a service of the Purdue University Libraries. Please contact epubs@purdue.edu for additional information.

Complete proceedings may be acquired in print and on CD-ROM directly from the Ray W. Herrick Laboratories at <https://engineering.purdue.edu/Herrick/Events/orderlit.html>

NUMERICAL SIMULATION OF COMPLEX THERMAL SYSTEMS INVOLVING MULTIPLE FIN-AND-TUBE HEAT EXCHANGERS

Carles OLIET, Carlos D. PEREZ-SEGARRA, Assensi OLIVA

Centre Tecnològic de Transferència de Calor CTTC,
Laboratori de Termodinàmica i Energètica,
Dept. Màquines i Motors Tèrmics. Universitat Politècnica de Catalunya,
Colom 11, 08222 Terrassa (Barcelona), Spain
Fax: +34-93-739.89.20, Tel. +34-93-739.81.92
E-mail: labtie@labtie.mmt.upc.es, Web page: <http://www.cttc.upc.edu>

ABSTRACT

The aim of this paper is the presentation of a numerical tool (multiCHESS) developed for the analysis of complex thermal systems involving fin-and-tube heat exchangers (with particular interest in air-handling units and engine cooling modules). The research conducted has been focused on the extension of previous fin-and-tube heat exchanger numerical tools (Oliet *et al.*, 2002), (Oliet *et al.*, 2000) in order to take into account the thermal and fluid-dynamic interactions with the rest of the thermal system. After a brief explanation of the numerical procedure implemented, the paper presents illustrative numerical results on situations identified as being basic modules encountered in HVAC and automotive thermal systems: i) fan coupling with a flow resistance; ii) two heat exchangers of different size; iii) ventilating unit; iv) cooling and dehumidifying unit.

1. INTRODUCTION

The industrial concerns on the optimisation of complex thermal systems involving fin-and-tube heat exchangers (air-handling units, engine cooling modules) have promoted the interest of extending previous research work conducted by the authors on such type of heat exchangers. The direct use of CFD has been presented in the open literature to analyse similar applications (Xu *et al.*, 1996), (Matsushima *et al.*, 2000), (Uhl *et al.*, 2001). However, this option is too time-consuming to be used as an industrial rating and design tool, where technical answers including parametric studies, analysis of several lay-outs, etc. are needed within a short time period. Therefore, a 1D-network code capable of linking the actual heat exchanger analysis with other coils, fans, filters, dampers, etc. has demonstrated that it is necessary for industrial purposes. Such a code has been developed to calculate flow distribution, mixing, etc. within intricately flow streams crossing those unit components. Other 1D-simulation tools for the analysis of complex thermal systems have been presented in the literature (Grose and Austin, 2001), (Luo *et al.*, 2003), (Salsbury and Diamond, 2000). From the authors point of view, the currently presented code is a relevant contribution on the coupling of advanced air-cooled heat exchangers modelling with the rest of the system.

2. HEAT EXCHANGER MODELLING

The previous code for heat exchanger simulation (CHESS) has been updated and revised to allow the computation of multi-coil situations. The input data module has been totally renewed to take into account non-uniform air inlet conditions. The output data module has been extended to generate a file that contains the air outlet conditions in a matrix-like form. This information will be fundamental when two heat exchangers hardly have air mixing between each other. The code has also been improved by the introduction of a set of command line arguments that allow CHESS calling by multi-coil procedure in an easy and flexible way.

The input data module has been totally revised to allow the reception of a matrix-like air-side input data, instead of uniform inlet conditions as carried out previously. Each magnitude (temperature, pressure, velocity, humidity) has its own independent grid of values; this feature is very useful when dense matrices are only present in one magnitude (i.e. temperature, when comparing to experimental results obtained by a thermocouple grid). When a multi-stream air-side simulation is carried out, or when multi-block CFD simulation techniques are applied, the data upstream the HEX is organised in zones with their own mesh density and/or air conditions. CHESS input data has been updated to receive this data in a multi-zone and matrix-like form.

The frontal area of the heat exchanger can be (in the most complex case) divided into several rectangular zones (Figure 1). Each zone is related to a flow stream of the air distribution module and will normally have different conditions as compared to other zones. Moreover, non-uniform magnitude (temperature, pressure, velocity and humidity) profiles are expected within each zone. This approach has the necessary complexity and flexibility to allow the calculation of heat exchangers located inside air-handling units and other thermal systems.

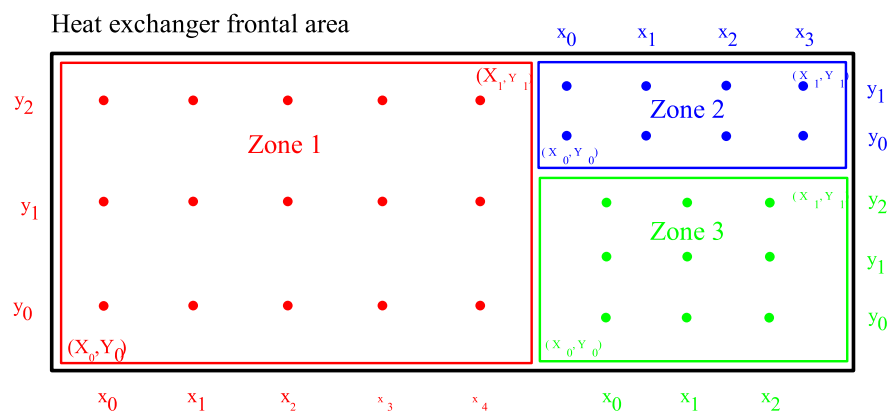

Figure 1: CHESS multi-zone and matrix-like air input data.

The multidimensional approach of multi-coil situations have created the necessity of generating an output file with the air outlet matrix information. It contains the detail of the CHESS grid and temperature, pressure, velocity and humidity matrices. This file will be fundamental for the correct transfer of data between the heat exchanger code and the multi-coil manager. This is specially important when two heat exchangers are very close to each other and direct transfer of matrix-like information is necessary.

The heat exchanger code has also been improved by the introduction of a set of command line arguments. In general, the multi-coil procedure can call CHESS module in an easier and more flexible way. Background execution has been introduced as a possibility; the graphics can then be switched off if multiple calls are present or if the program is sent to run on a remote computer. The quantity of output data and the error exigency can also be controlled at different levels. The possibility of loading previous back-up files have lead to considerable computational time savings.

3. COMPLEX THERMAL SYSTEMS MODELLING

The increased necessity to study the heat exchangers taking into account the surrounding environment, their relation with other elements in complex thermal systems, etc. has led to the development of a 1D-network code (multiCHESS) that couples the simulation of heat exchangers (by CHESS or other codes), fans, filters, etc. with a distribution/mixing subroutine.

The air-flow has been modelled as a series of “air-paths” corresponding to the main elements in the thermal system (HEX blocks, fans, filters, channels, bypasses, etc.). As a consequence, a flexible set of branches and nodes has all the information on the circulation of air flow through the system. A distribution procedure

determines the air flow through each branch and the pressure, temperature and humidity conditions at the nodes. Additional subroutines corresponding to each element will take the information of its flow and the conditions at the surrounding nodes. After calculation, they return the new connection edge conditions (i.e. actual thermal and fluid-dynamic response) to the distribution procedure. Mass flow or pressure boundary conditions can be specified at every node.

Therefore, the first step to simulate a complete air-handling system is to analyse it and to define a set of flow paths and a series of points (Figure 2) where they mix and have common properties (temperature, pressure and humidity). When two physical elements are very close to each other (e.g. heat exchangers), the outlet information of the first element should be passed directly in matrix-like form (without mixing) to the downstream element.

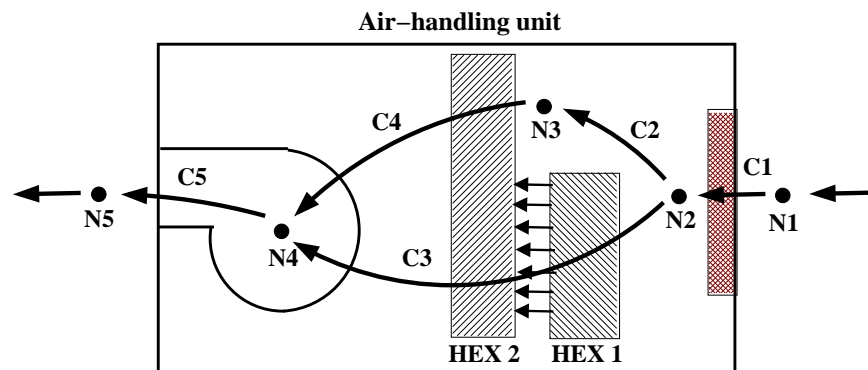

Figure 2: Air handling system sketch with the corresponding multiCHESS topology; example of direct transfer of information between two heat exchangers.

Once the basic topology has been defined, each flow path has to be assigned to one element (or part) of the air-handling system. Boundary conditions must be defined at certain nodes to state the problem correctly: mass flow or pressure conditions can be determined, together with temperature and humidity levels. The elements data-base or specific simulations will provide their fluid-dynamic and thermal behavior, explicitly given by the connection updated edge values. All this information is included in a simple and flexible input data file.

A distribution procedure has been therefore developed for the calculation of the air mass flow circulating through each branch within the system and the pressure at each node. The applied methodology is a unidimensional adaptation of the SIMPLE algorithm to solve Navier-Stokes equations (Patankar, 1980). At the same time, mixing procedures will provide the average temperature and humidity conditions at each node and the corresponding inlet values for the connections that extract air flow from that node. The SIMPLE algorithm obtains iteratively the connection mass flows from the momentum equation, and by modification of the mass conservation equation, determines correction values for pressure and mass flows to accomplish the mass balance. Between SIMPLE iterations, the parameters of each branch are recalculated by every “independent” element calculation procedure, which gets the scalar values at the neighbor nodes and the mass flow from the flow distribution calculator.

4. NUMERICAL RESULTS

4.1 Single fan against a flow resistance

In this section, the couple fan-resistance simulation is presented, as one of the most used fundamental elements in complex thermal systems. For the case with a fan and a resistance located in series in a duct of the same section, the values of the resistance have been varied and the corresponding working points have been obtained (Figure 3). The results are obviously on the fan total pressure curve and are progressively

displaced to lower flow values as resistance is increased. A commercial axial fan has been selected because of the availability of detailed performance information.

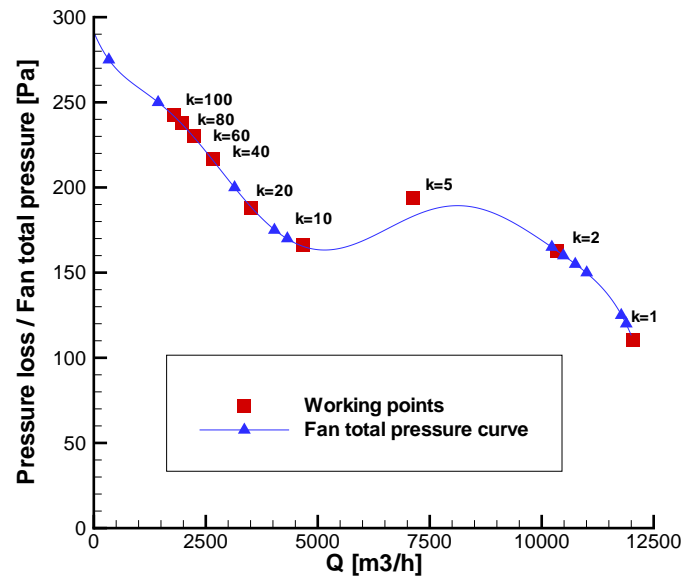

Figure 3: Fan and flow resistance in series: working points varying flow resistance values.

4.2 Two heat exchangers of different size

One of the most complex situations involving heat exchangers in air handling units or engine cooling modules is encountered when two heat exchangers of different size are located very close to each other, thus avoiding air flow mixing between them. In Figure 4 a sketch of this situation and the main air flows involved is presented. The capability of multiCHESS to analyse this case and to define a flow stream formed by two heat exchanger blocks corresponding to different heat exchangers is highlighted in this section. The outlet data of the upstream heat exchanger (HEX 1) is given in matrix-like form (with no mixing) to the corresponding HEX 2 block. The rest of the HEX2 inlet data is formed by the upstream inlet values from the rest of flow streams, considered uniform at this stage.

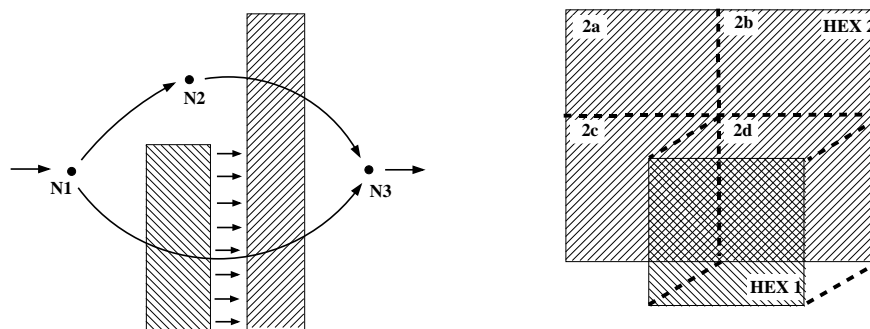

Figure 4: Sketch of the case with two heat exchangers with no mixing between them.

HEX 1 has been defined as a heater and HEX 2 as a cooler and dehumidifier. As long as the heater works with no relevant differences compared to working alone at the same boundary conditions, the attention is

focused on the cooler located downstream. In Figure 5 the inlet and outlet temperature maps are presented, where the influence of the upstream heater can be easily identified. Note that not only temperature and relative humidity is being influenced by HEX 1, but the velocity is also lower in the HEX 2d block because of the introduction of the corresponding additional heater flow resistance.

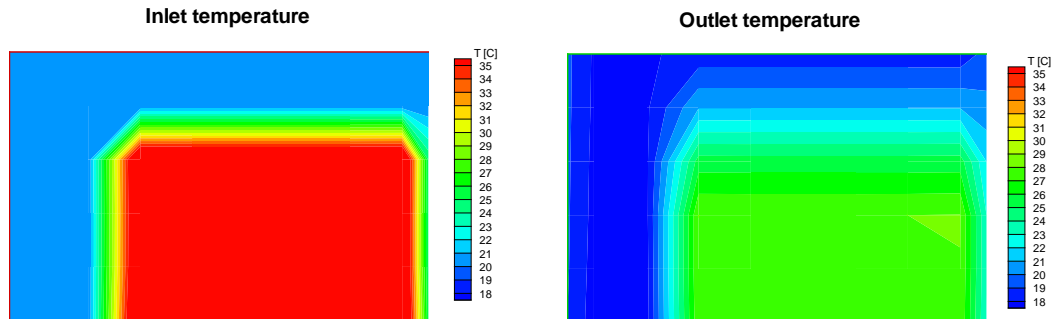

Figure 5: HEX 2 (cooler and dehumidifier): inlet and outlet frontal temperature maps.

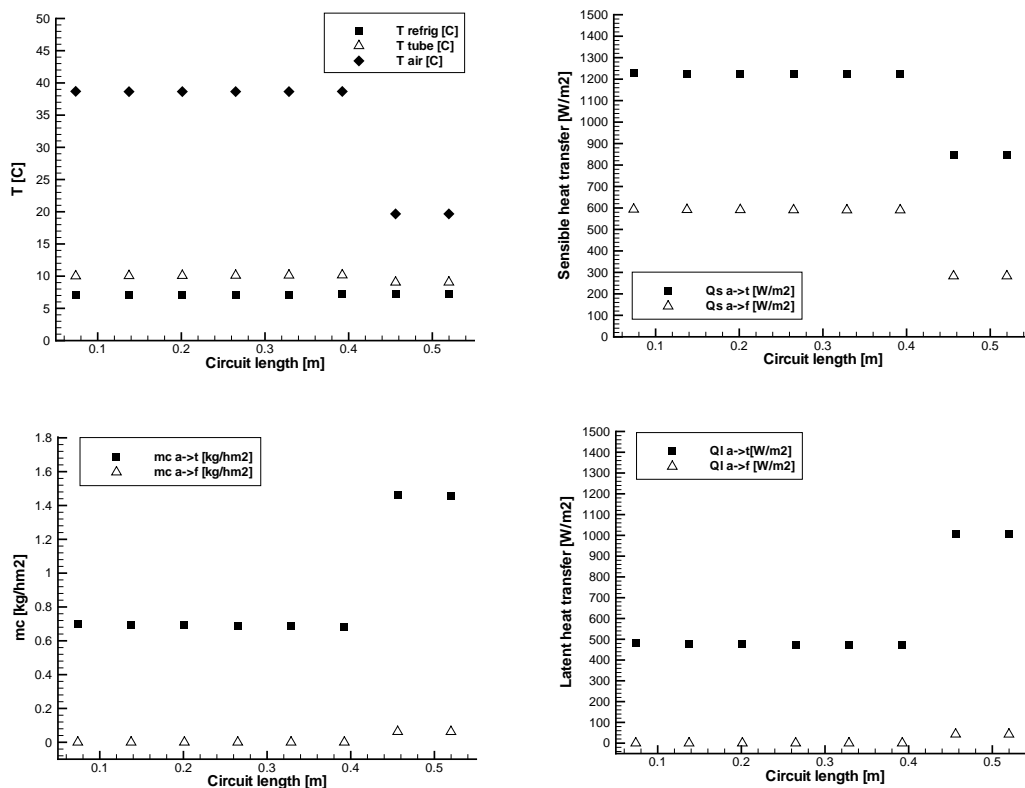

Figure 6: HEX 2 first tube bottom-left: temperature, condensate rate and sensible/latent heat transfer local values.

Figure 6 shows the local temperature, water condensate rate (\dot{m}_c) and sensible/latent heat transfer rate calculated by the numerical code for the bottom-left first tube of HEX2. The information given is highly valuable as it provides local information on the downstream effects introduced by the upstream heater.

Plotted values change drastically after the length of 0.4 m, which is precisely the length of the upstream heater: i) Air temperature and sensible heat transfer drop significantly from 0.4 to 0.5 m, reflecting the air bypass that does not cross the heater; ii) Water condensate and latent heat transfer rates decrease strongly behind the heater, because higher air temperature produces higher fin temperature (even air water content does not change).

4.3 Ventilating unit

In this section, a ventilating unit is simulated using multiCHES. The chosen configuration is formed by two fans and three dampers (Figure 7). Two main flow streams connecting the conditioned space with the outdoors environment are inter-connected by a damper to control the incoming air flow conditions to the room. This is a simplification of a usual configuration for industrial air-conditioning and ventilating units, where the presence of heat exchangers has been avoided in this case.

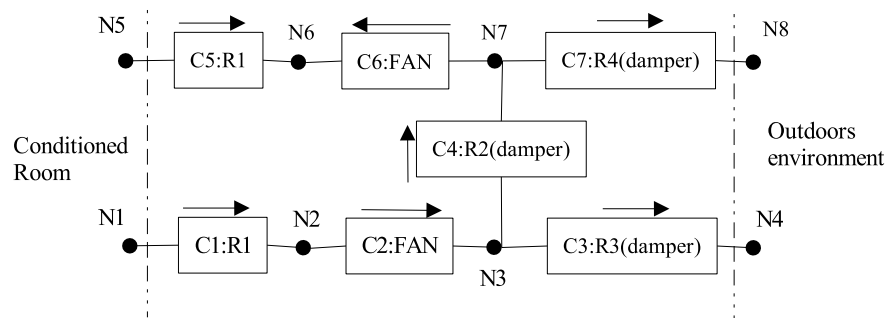

Figure 7: Ventilation system: corresponding net of fans and flow resistances.

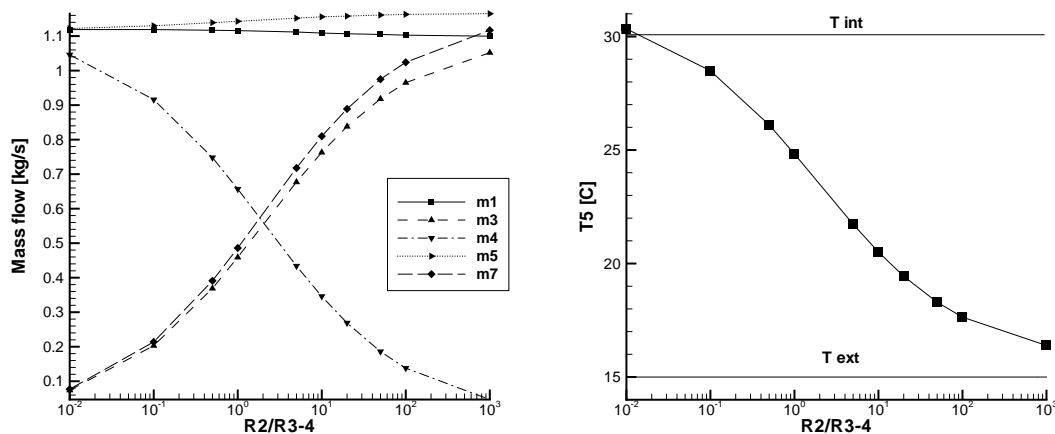

Figure 8: Results for a variable $R2$ damper.

A typical commercial axial fan has been selected for both fans. As an illustrative study, the results obtained by fixing dampers $R1$, $R3$ and $R4$ flow resistances ($R1 = 20$, $R3 = R4 = 1$) and varying damper $R2$ flow resistance are presented in Figure 8. As expected, the higher $R2$ values lead to room incoming conditions closer to outdoor conditions, while low $R2$ values provide incoming states closer to indoor conditions. Although these results are preliminary and only for demonstration purposes, they show the ability of multiCHES to simulate and obtain significant results for the design and control of such complex systems.

4.4 Cooling and dehumidifying unit

In this section, the attention is centred on the pair of heat exchangers (cooler-heater) encountered in the majority of air-handling units, providing some results of a detailed parametric study carried out using multiCHESS.

Both heater and cooler have been taken with the same geometry and circuitry. The coolant mass flow has also been fixed to the same value. The inlet air flow coming into the module has constant temperature and humidity values. Therefore, the variable parameters in this study have been the air inlet velocity (v_{air}), the cooler inlet coolant temperature (T_c) and the heater inlet coolant temperature (T_h). The relative position of the coils regarding the inlet air flow has also been studied: heater plus cooler (h+c) and cooler plus heater (c+h).

Analysing the outlet temperature conditions, their values are much higher for the c+h layout, which indicates that a smaller heater will be sufficient to obtain the same results as h+c arrangement. Therefore, from a thermal point of view, the c+h layout is clearly more efficient for this case. In the same way, the absolute humidity values are studied against cooler coolant inlet temperature for different heater coolant inlet temperature, constantly varying air frontal velocities. The outlet humidity values are lower for the c+h layout, thus having higher dehumidification rates. As expected for this layout, the heater temperature does not affect cooler performance. The outlet temperature conditions for both configurations are shown in Figures 9 and 10.

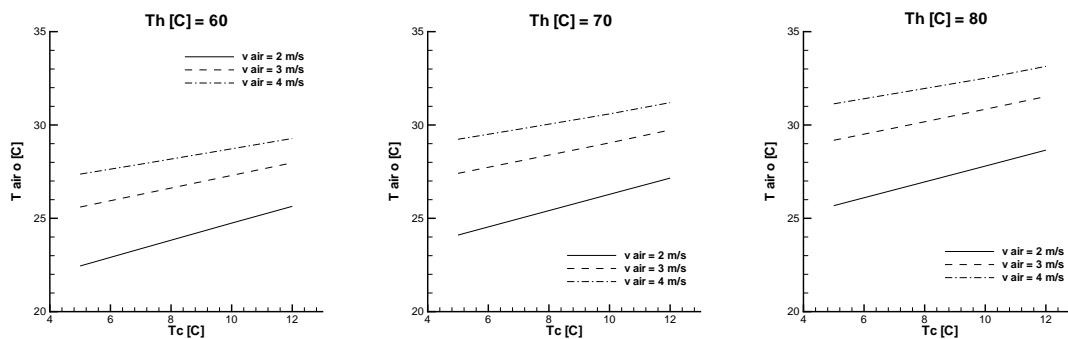

Figure 9: Air outlet temperature conditions for the h+c arrangement.

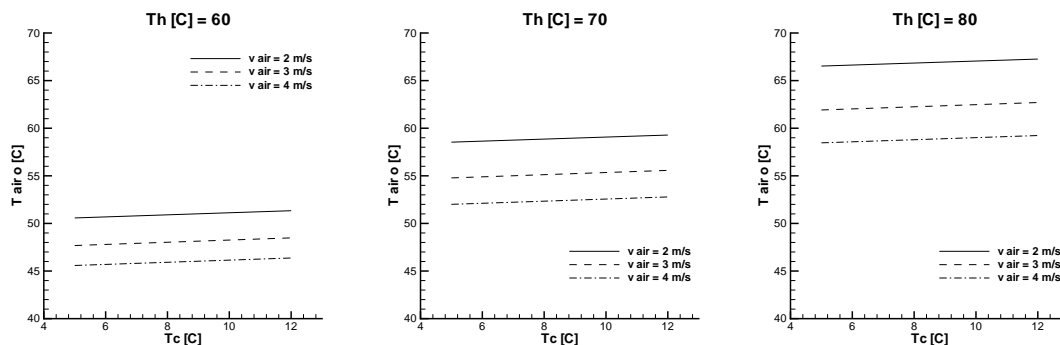

Figure 10: Air outlet temperature conditions for the c+h arrangement.

5. CONCLUSIONS

The modelling of complex thermal systems involving fin-and-tube heat exchangers has been presented providing an overview of some studies performed on basic modules usually encountered in air-handling units, engine-cooling modules, etc. An introduction is provided on the previous fin-and-tube heat exchanger code (CHESS) adaptation to multi-zone non-uniform air inlet data for a later brief explanation of the 1D-network code (multiCHESS) developed to link the simulation of the air-cooled heat exchangers with the rest of the system.

The paper presents illustrative numerical results on situations identified as being basic modules encountered in HVAC and automotive thermal systems: i) fan coupling with a flow resistance; ii) two heat exchangers of different size; iii) ventilating unit; iv) cooling and dehumidifying unit. From these studies, the numerical effort will be focused in the future on the simulation of complete commercial complex systems considering all the components, where systematic parametric studies will be carried out for optimisation purposes. CFD simulation using porous medium approach has also been developed by the authors as the highest level simulation tool to be applied to cases of special interest. Experimental work is also being performed on a heat exchanger testing tunnel to validate these numerical tools.

REFERENCES

- Grose, D., Austin, K., 2001, Coupling of one dimensional and three dimensional simulation models, *The Proceedings of the Vehicle Thermal Management Systems Conference*, SAE: Technical Paper Series 2001-01-1770.
- Luo, X., Guan, X., Li, M., Roetzel, W., 2003, Dynamic behaviour of one-dimensional flow multistream heat exchangers and their networks, *Int. J. Heat Mass Transf.*, vol. 46, no. 4:p. 705–715.
- Matsushima, Y., Takeuchi, T., Kohri, I., 2000, Prediction method of engine compartment air flow using CFD analysis, *JSAE Rev.*, vol. 21, no. 2:p. 197–203.
- Oliet, C., Pérez-Segarra, C., García-Valladares, O., Oliva, A., 2000, Advanced numerical simulation of compact heat exchangers. Application to automotive, refrigeration and air conditioning industries, *Proceedings of the Fifth ECCOMAS Computational Fluid Dynamics Conference*, ECCOMAS: CD-ROM.
- Oliet, C., Pérez-Segarra, C.D., Danov, S., Oliva, A., 2002, Numerical Simulation of Dehumidifying Fin-and-Tube Heat Exchangers. Model Strategies and Experimental Comparisons, *Proceedings of the 2002 International Refrigeration Engineering Conference at Purdue*, Purdue University: CD-ROM paper R5-5.
- Patankar, S., 1980, *Numerical heat transfer and fluid flow*, Hemisphere, Whashington DC, 197 p.
- Salsbury, T., Diamond, R., 2000, Performance validation and energy analysis of HVAC systems using simulation, *Energy Build.*, vol. 32, no. 1:p. 5–17.
- Uhl, B., Brotz, F., Fauser, J., 2001, Development of Engine Cooling Systems By Coupling Cfd Simulation and Heat Exchanger Analysis Programs, *Proceedings of the Vehicle Thermal Management Systems Conference*, SAE: Technical Paper Series 2001-01-1695.
- Xu, Z. G., Gotham, D. H. T., Collins, M. W., Coney, J. E. R., Sheppard, C. G. W., Merdjani, S., 1996, CFD Prediction of Turbulent Recirculating Flow in an Industrial Packaged Air-Conditioning Unit, *HVAC&R Res.*, vol. 2, no. 3:p. 195–214.

ACKNOWLEDGEMENTS

This research work has been partially funded by the European Community under the Fifth Framework Programme, Thematic Programme Energy, Environment and Sustainable Development (“COMHEX” project, contract no. CRAFT-1999-71024).