

**Purdue University**  
**Purdue e-Pubs**

---

International Refrigeration and Air Conditioning  
Conference

School of Mechanical Engineering

---

2000

# Development of Energy Optimal Capacity Control in Refrigeration Systems

A. Jakobsen

*Technical University of Denmark*

B. D. Rasmussen

*Technical University of Denmark*

M. J. Skovrup

*Technical University of Denmark*

J. Fredsted

*Danfoss*

Follow this and additional works at: <http://docs.lib.purdue.edu/iracc>

---

Jakobsen, A.; Rasmussen, B. D.; Skovrup, M. J.; and Fredsted, J., "Development of Energy Optimal Capacity Control in Refrigeration Systems" (2000). *International Refrigeration and Air Conditioning Conference*. Paper 499.  
<http://docs.lib.purdue.edu/iracc/499>

This document has been made available through Purdue e-Pubs, a service of the Purdue University Libraries. Please contact [epubs@purdue.edu](mailto:epubs@purdue.edu) for additional information.

Complete proceedings may be acquired in print and on CD-ROM directly from the Ray W. Herrick Laboratories at <https://engineering.purdue.edu/Herrick/Events/orderlit.html>

# DEVELOPMENT OF ENERGY OPTIMAL CAPACITY CONTROL IN REFRIGERATION SYSTEMS

Arne Jakobsen (aj@et.dtu.dk), Bjarne Dindler Rasmussen, Morten Juel Skovrup  
Dept. of Energy Engineering, Technical University of Denmark  
DK-2800 Kgs. Lyngby, Denmark

Jakob Fredsted, Danfoss Inc., DK-6430 Nordborg, Denmark

As a result of the introduction of variable speed compressors, variable speed fans, and variable speed pumps in a refrigeration system the degree of freedom of the overall control system increases - making energy optimisation by intelligent system control feasible. As a consequence of these new possibilities the ideal control method of a refrigeration system changes from being a number of independent single-input single-output controllers (SISO) to a multiple-input multiple-output system (MIMO).

Furthermore, combining energy optimal capacity control with intelligent fault detection and diagnostics to ensure high performance increases the potential for reduction of running costs.

The above mentioned possibilities are illustrated/investigated by evaluation of the results from the use of a relatively simple system simulation model.

## NOMENCLATURE

N	rpm	Speed or Capacity	Indices	
$T_A$	°C	Ambient temperature	C	Compressor
$T_R$	°C	Cold room temperature	EF	Evaporator fan
$\dot{W}$	kW	Power consumption	WP	Water pump
$\phi_A$	%	Ambient relative humidity	CtF	Cooling tower fan

## INTRODUCTION

The operation of a refrigeration plant is not better than its control and its level of maintenance! Nobody will probably argue against this statement but in many cases proper attention to these issues seems to be lacking. If the temperature of the object that is cooled is within the desired limits, then only rarely more attention will be given to the refrigeration plant. In many cases the power consumption of the compressors (and auxiliary equipment) are not even measured. This means that the operator has no direct indicator of "how well the plant is running" in terms of total power consumption.

Variable speed capacity control of active components (compressors, fans, pumps etc.) is implemented more and more. In some cases the capacity of the auxiliary equipment is adjusted when the plant is commissioned but otherwise kept constant. In some cases the capacity is managed by e.g. PID-control loops, i.e. the condenser capacity is controlled by adjusting fan speed based on a refrigerant pressure measurement. But in nearly all cases the setpoints are kept constant and the implemented controllers are single-input-single-output. The opportunities for overall energy savings having on-line calculation of "system-intelligent" setpoints to all active components are seldom pursued.

For a given refrigeration plant and given cooling and temperature demands, a minimum of the total energy consumption of all active components exists. Two main factors determine how close the operation gets to the optimum: the actual efficiencies of the components and the combination of the actual capacities of the active components. The former is a matter of whether the efficiency of the components lives up to reasonable expectations and adequate maintenance. The other factor is the "system capacity control". To illustrate the degree of freedom (leaving room for optimisation) of the system, let's assume that the actual cooling capacity has to be increased a bit (the object in question is a little too warm). The traditional way is to increase the capacity of the compressor(s). This can be done in many ways, but suppose this can be done continuously for example by adjustment of the speed of the compressor. That is, to a specific marginal extra demand of cooling capacity, a corresponding increment of compressor speed - and also compressor power consumption - exist. The same marginal increase of cooling demand could probably be obtained by increasing the speed of the evaporator fan (in the case of an air-cooler, in the case of a liquid chiller the speed of a pump could be increased). Under most operating conditions lowering the condenser pressure could also increase the cooling capacity. Generally, an increase in any active component will increase the actual cooling capacity - the optimisation problem is to do this in a manner where the total power consumption of all active components are minimised (observing some process and component constraints).

The corrective actions related to minimisation of the overall power consumption is illustrated in Figure 1.

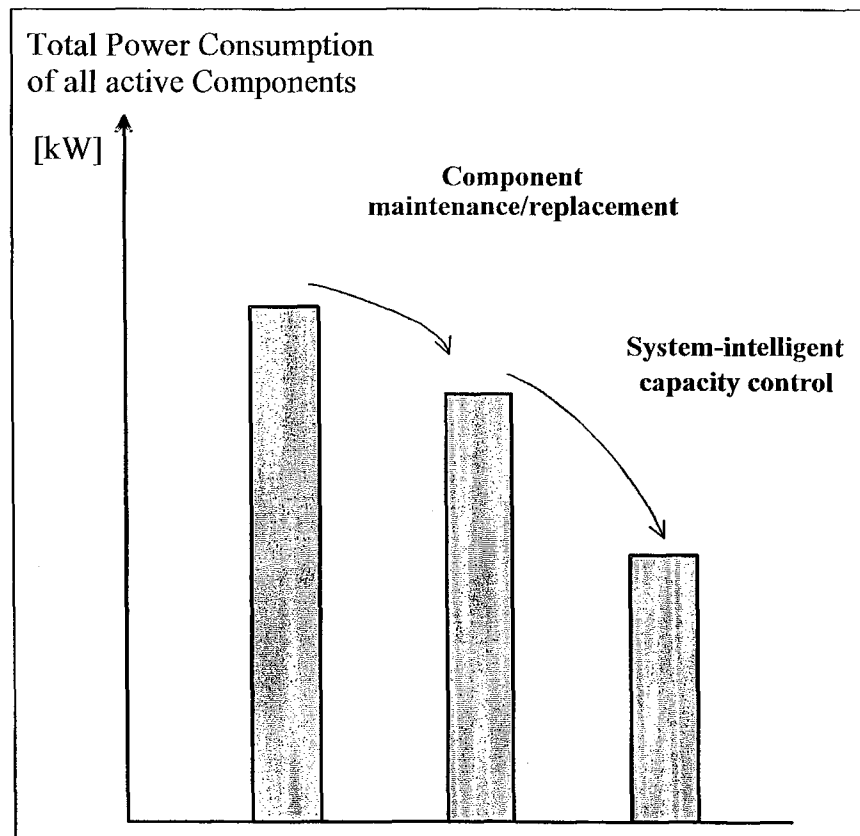

**Figure 1:** Corrective actions reducing the overall power consumption.

In Figure 2, a "flow of decisions" is illustrated based on measurements. The first question, which seems natural to ask, but perhaps is difficult to answer, is: is the operation of the system "close enough" to its optimum? If no, then corrective actions are needed to improve the overall energy efficiency of the system. The corrective actions fall into two major categories. If the efficiencies of the components are less than they could and should be, then maintenance or replacement is needed. Another question - which might be even more difficult to answer - is whether the actual refrigeration capacity is produced by the energy-optimal combination of capacities of all the active components involved.

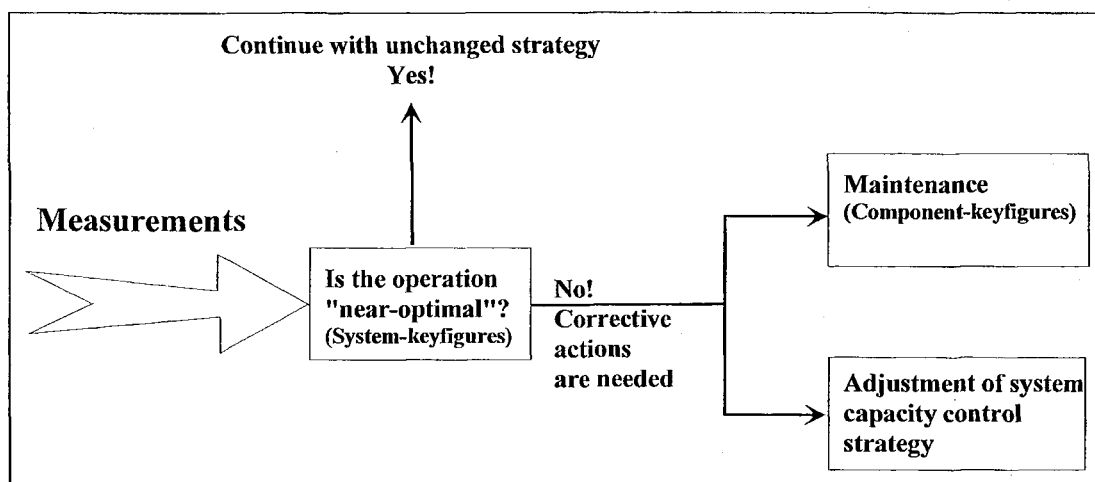

**Figure 2:** Principle "flow" of decisions combining fault detection and energy-optimal control.

In [1] the challenge and potential for introducing variable speed of the active components are treated. The work described in the present paper is a natural continuation of these preliminary investigations.

Malfunctions and faults on commercial refrigeration systems (like other application areas) are most often not discovered before the cooling capacity is reduced to an extent, where temperatures can no longer be maintained. In some cases no action is taken before severe damage on components or frozen fresh food is detected. Until action is taken the refrigeration system often runs with poor efficiency, and in some cases with higher wear on components. Consequently, early detection of operating disturbances and beginning faults is desirable, see [2] and the references therein.

Traditional single-input single-output (SISO) control systems do not take into account, that the vapour compression process is a multi-variable system characterised by strong cross-couplings and non-linearities. Therefore, a (MIMO) system integrating variable capacity control combined with electronic control on other active components, is able to improve the process performance – especially the transient behaviour. Examples of this are illustrated in [3] and [4].

## CASE

In order to illustrate the optimisation problem (challenge) a simple case is treated. The objective, besides getting a feel for the nature of the problem, is also to get an idea of the potential for energy savings (or penalties if the operation is not optimal). The case chosen is depicted in Figure 3, below.

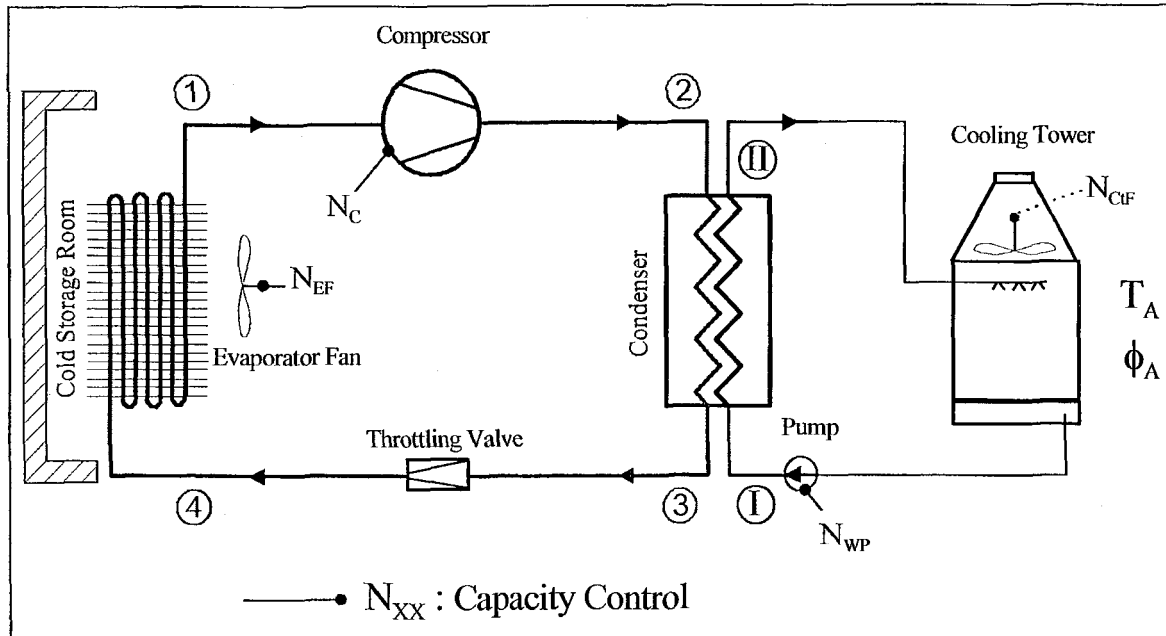

Figure 3: Simple case with four active components.

The case chosen is a cold storage room with an air-cooler. The condenser heat is rejected via a cooling tower. There are four active components involved: the compressor, the evaporator fan, the cooling tower fan and the water pump. In this case, it is assumed that the capacity of all active components can be controlled continuously by means of variable speed. The evaporator superheat is maintained constant by a thermostatic expansion valve, that is assumed to be able to handle the capacity range, i.e. maintain low superheat over the full range of operation.

The design point is:

Cold room temperature	: 5 °C	Cold room load	: 35 kW
Ambient temperature	: 25 °C	Ambient air humidity	: 55 %

## SIMULATION MODEL

Relatively simple system simulation models are developed for both steady state and transient conditions. The former is primarily used for parameter sensitivity investigations, whereas the latter is developed for investigation of control strategies. The steady state model is implemented in EES (Engineering Equation Solver, refer to: [www.fchart.com](http://www.fchart.com)) and the dynamic model is implemented in WinDali (DAE-solver program developed at Department of Energy Engineering, Technical University of Denmark).

The main thermal capacities in the dynamic model are the goods in the cold storage room and the water on the warm side. The refrigerant cycle itself is modelled quasi-static.

Only results using the steady-state system model are shown in this paper. The investigations of actual control strategies are published later-on.

The model of all the active components are assuming a constant component (isentropic) efficiency, which is taken as a model parameter.

## RESULTS

The optimisation control problem can be formulated as following:

$$\begin{aligned} & \text{Min} (\dot{W}_C + \dot{W}_{EF} + \dot{W}_{WP} + \dot{W}_{ClF}) \\ & N_C, N_{EF}, N_{WP}, N_{ClF} \mid T_R = 5,0^\circ\text{C} \end{aligned}$$

The equation above expresses that the total power consumption of all active components must be minimised by variation of the their respective capacities having the constraint that the air in the cold room is 5 °C.

Beside equation solving, EES is capable of doing numerical optimisation and in the case described the key-results for the optimal control operation is:

Optimal Values	$\dot{W}_{TOT}$	$\dot{W}_C$	$\dot{W}_{EF}$	$\dot{W}_{WP}$	$\dot{W}_{ClF}$
kW	10,881	9,277	0,508	0,255	0,842
%	100	85,3	4,7	2,3	7,7

The corresponding evaporation and condensing temperatures are  $-6,6^\circ\text{C}$  and  $31,5^\circ\text{C}$  respectively.

An interesting question is how sensitive the total power consumption is to operation deviating from the optimal point. The results from such a sensitive study are shown the Figure 4, 5, and 6. The capacity of the compressor adapts to keep the cold room temperature at 5,0 °C.

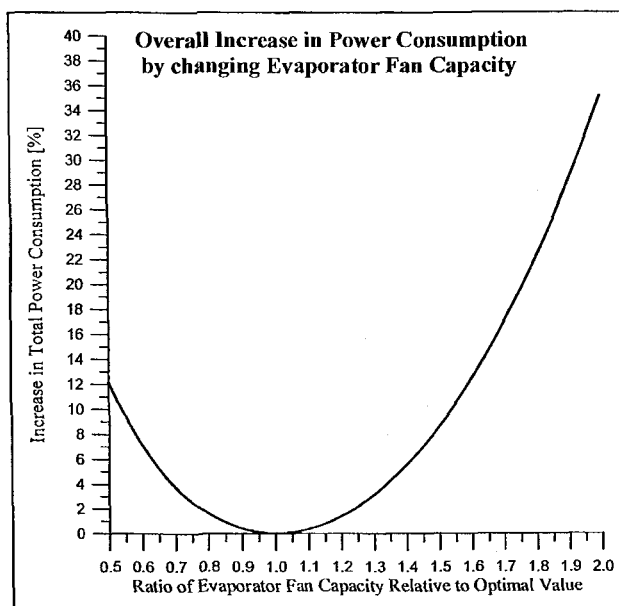

On Figure 4 the overall increase in power consumption is shown changing the evaporator fan capacity away from its optimal value. It is seen that  $\pm 10\%$  deviation results in an increase of less than one percent. But the relationship is quite progressive and it appears that changing the capacity downward by 50 % results in an overall increase of power consumption of approx. 12 %. Doubling the capacity of the fan compared to the optimal value gives an increase of the total power consumption of as much as 35 %.

**Figure 4:** Relative penalty in power consumption by operating the evaporator fan away from optimum.

The corresponding results operating the water pump and the cooling tower fan away from the optimal point are shown below.

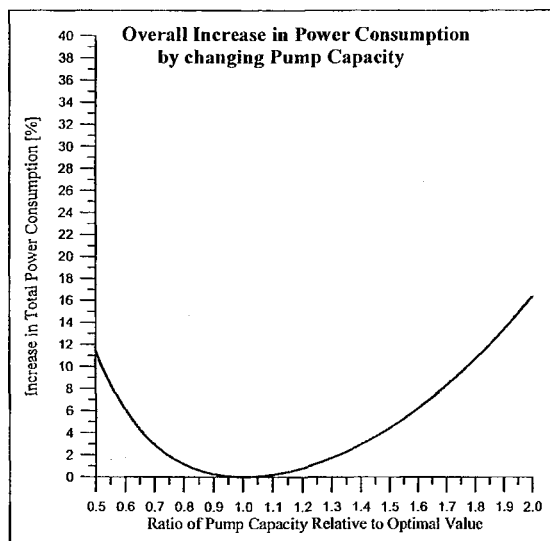

Figure 5: Change of pump capacity.

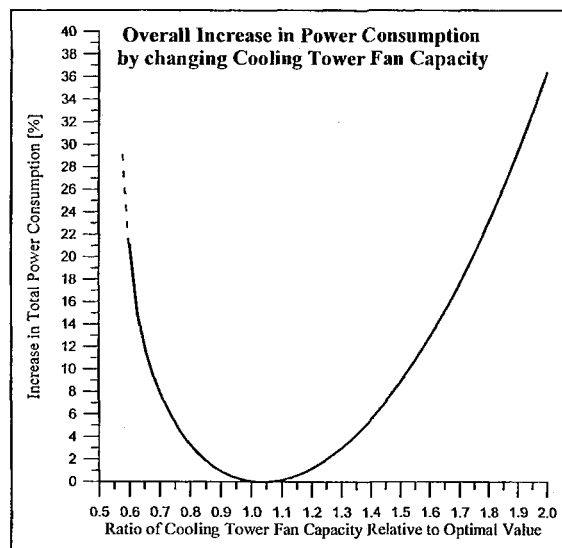

Figure 6: Change of cooling tower fan cap.

The overall conclusion is that the total power consumption is quite insensitive to relatively small deviations of the capacities of the auxiliary equipment from their optimal values. But the relationship is quite progressive, which means that say doubling their capacity leads to significant increase of the total power consumption.

The energy penalty of the traditional control keeping either the capacity of the auxiliary equipment constant or keeping constant evaporation and condensation pressures is illustrated below in Figure 7 and 8.

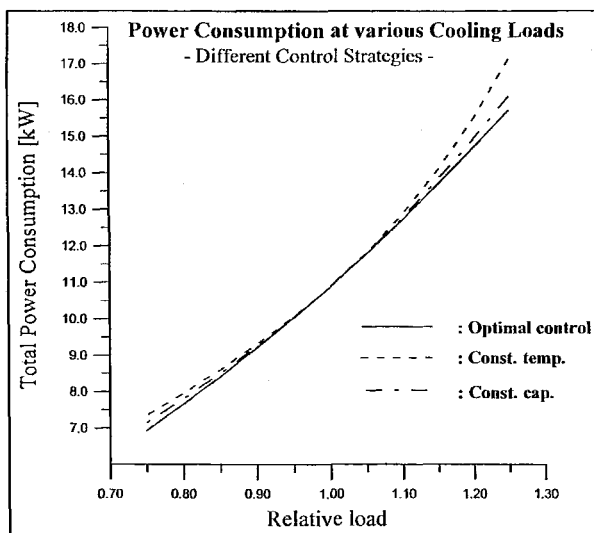

Figure 7: Power consumption at var. loads.

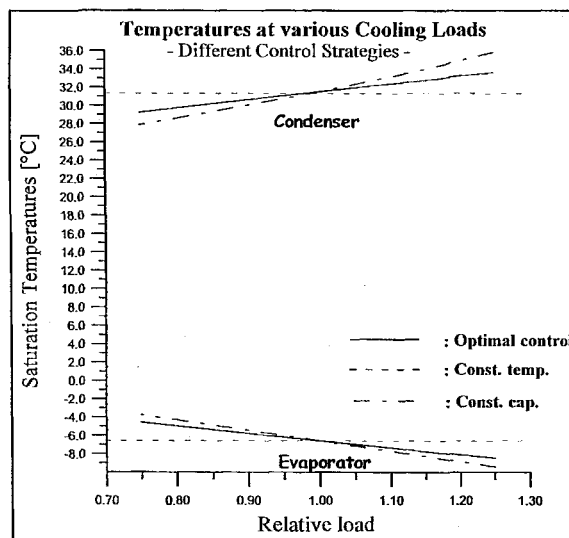

Figure 8: Corresponding saturation temp.

## CONSIDERATIONS ON CONTROL STRUCTURE

To realise the full potential of the variable speed compressor, the right choice of control strategy, becomes vital. As demonstrated in [4], traditional decoupled single-input single-output (SISO) feedback control, will have limited performance in terms of transient behaviour, due to the strong cross couplings between the feedback loops. Instead a multi-variable control strategy is required.

In this paper a control strategy is suggested where a set of “low-level” SISO controllers handle the set point control and one supervisory “high-level” controller takes care of the set point co-ordination to all of the “low-level” control loops. That is, the “system-intelligent” setpoints are calculated at the “high level”. Due to space limitation it is not possible to go into detail with an optimal strategy of calculating these setpoints to the internal process variables indicated below in Figure 9. Introductory investigations indicates that when the operation is changing due to change of cooling load then all setpoints must be adjusted in a way which nearly results in a unchanged relative distribution of power consumption of the active components. This also means that the process setpoints are adjusted such that they are in between keeping them constant and keeping the capacities of the auxiliary equipment constant.

The “low-level” loops are handled by traditional PID-controllers with anti-integration wind-up. One more advanced feature is to equip these PID-loops with algorithms for automatic-tuning, e.g. relay-feedback.

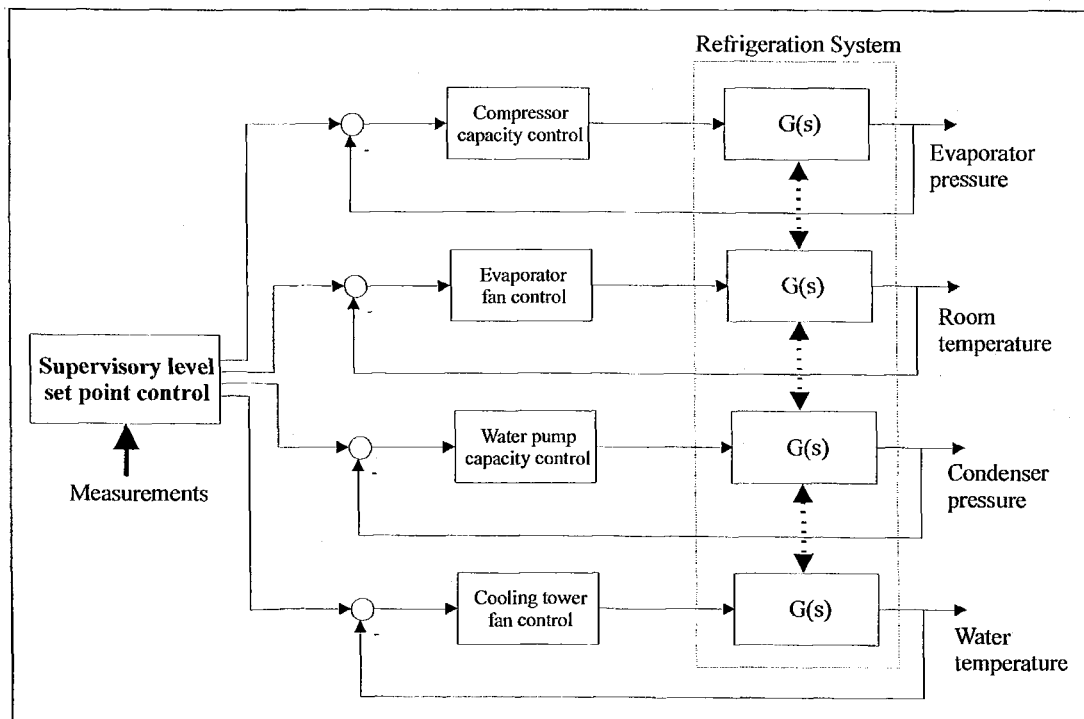

Figure 9: An example of control structure



## CONCLUSIONS

It is argued that significant savings in operation cost are feasible by introduction of control and maintenance actions, which ensures that the system operates close to its energy minimum. The relationship between total power consumption and capacities of the active components is progressive. This means that being "far" from optimum even small adjustments have severe impact on the total power consumption. The timing for focusing on system-intelligent control and diagnostics seems right. In fact we have already a lot of options today, which are not benefited from. Already implemented measurements and equipment could be used more directly in component and system diagnostics. The cost of electronic control is rapidly decreasing, whereas their efficiencies are increasing. The development and implementation of strategies for better performance of the overall system having variable capacity of all active components are only in their infancy.

## FUTURE WORK

A lot of challenging work is in front of us before the problems/possibilities indicated in this paper are fully explored. Some of the tasks are listed below:

- A consistent set of component and system key-figures are developed
- A robust and consistent control/diagnostics structure is developed, tested and evaluated
- Control methods seeking for the system energy optimal combination of capacities of active components are developed, tested and evaluated
- Methods for diagnostics of the state of the components and the corresponding corrective actions are developed, tested and evaluated

## ACKNOWLEDGEMENTS

The Danish Energy Agency finances part of the work.

## REFERENCES

- [1] *Arne Jakobsen; Bjarne Dindler Rasmussen; Energy-optimal speed control of fans and compressors in a refrigeration system. Eurotherm Seminar, July 1998, Nancy, France. 7 pages, pp 317-323.*
- [2] *Mark S. Breuker; James E. Braun: "Evaluating the Performance of a Fault Detection and Diagnostic System for Vapor Compression Equipment", HVAC & R Research, Vol. 4, No. 4, Oct. 1998.*
- [3] *Jakob Fredsted; Jean De Bernardi: "Multi-Variable Control of Vapor Compression Processes", in proceedings 20<sup>th</sup> International Congress of Refrigeration, Sydney, 1999.*
- [4] *He X., Liu S., Asada H.H., Itoh, H., July, 1998, "Multivariable Control of Vapor Compression Systems", HVAC & R Research, Vol. 4, No. 3, ASHRAE, USA.*