

**Purdue University**  
**Purdue e-Pubs**

---

LARS Symposia

Laboratory for Applications of Remote Sensing

---

1-1-1979

# A Merged Satellite Infrared and Manually Digitized Radar Product

Marshall P. Waters

Robert N. Green

Follow this and additional works at: [http://docs.lib.purdue.edu/lars\\_symp](http://docs.lib.purdue.edu/lars_symp)

---

Waters, Marshall P. and Green, Robert N., "A Merged Satellite Infrared and Manually Digitized Radar Product" (1979). *LARS Symposia*. Paper 268.  
[http://docs.lib.purdue.edu/lars\\_symp/268](http://docs.lib.purdue.edu/lars_symp/268)

This document has been made available through Purdue e-Pubs, a service of the Purdue University Libraries. Please contact [epubs@purdue.edu](mailto:epubs@purdue.edu) for additional information.

Reprinted from

**Symposium on  
Machine Processing of  
Remotely Sensed Data**

**June 27 - 29, 1979**

The Laboratory for Applications of  
Remote Sensing

Purdue University  
West Lafayette  
Indiana 47907 USA

IEEE Catalog No.  
79CH1430-8 MPRSD

Copyright © 1979 IEEE  
The Institute of Electrical and Electronics Engineers, Inc.

Copyright © 2004 IEEE. This material is provided with permission of the IEEE. Such permission of the IEEE does not in any way imply IEEE endorsement of any of the products or services of the Purdue Research Foundation/University. Internal or personal use of this material is permitted. However, permission to reprint/republish this material for advertising or promotional purposes or for creating new collective works for resale or redistribution must be obtained from the IEEE by writing to [pubs-permissions@ieee.org](mailto:pubs-permissions@ieee.org).

By choosing to view this document, you agree to all provisions of the copyright laws protecting it.

# A MERGED SATELLITE INFRARED AND MANUALLY DIGITIZED RADAR PRODUCT

MARSHALL P. WATERS III AND ROBERT N. GREEN

National Environmental Satellite Service

## I. ABSTRACT

This paper describes an automated technique which uses digital data from a geosynchronous environmental satellite and conventional meteorological data mapped to the satellite's viewing projection. The technique produces a cloud-top height display with coincident manually digitized radar.

## II. INTRODUCTION

The National Environmental Satellite Service (NESS) of the National Oceanic and Atmospheric Administration (NOAA) operates two environmental satellite systems. These are the third generation of operational polar-orbiting satellites known as the TIROS-N series and the geostationary operational environmental satellites (GOES). The TIROS-N data provide mainly global quantitative products such as vertical soundings of the atmosphere and sea surface temperature. The GOES images the Western Hemisphere providing hard-copy "pictures" every 30 minutes. The GOES data are generally not mapped to standard projections to compare cloud images with other conventional meteorological fields of data. This paper will discuss an automated use of the digital GOES data along with conventional meteorological data mapped to the GOES projection in order to determine if coincident satellite and conventional meteorological data provide useful information not present in each alone and to determine the operational feasibility of providing such a product.

The GOES system consists of two operating satellites, the ground data acquisition station and a centralized data distribution system. The first satellite of this system was the Synchronous Meteorological Satellite (SMS-1), a NASA prototype for the GOES, launched in May 1974.

It was followed by SMS-2 in February 1975, GOES-1 in October 1975, and then GOES-2 in June 1977. The current configuration of the two satellites has SMS-1 (East) at 75°W and GOES-2 (West) at 135°W fixed over the equator at an altitude of about 36,000 km. The two GOES satellites are positioned to provide overlapping and continuous coverage of the Western Hemisphere. These two satellites will henceforth be referred to as GOES-East and GOES-West.

The two GOES satellites provide environmental data from the Earth's disk facing each satellite at periodic intervals, usually every 30 minutes. The environmental data from both satellite systems are routinely processed by NESS into a variety of quantitative and image products which are distributed to users. A complete listing of NESS products can be found in NOAA Technical Memorandum NESS 88<sup>1</sup>.

The primary instrument of the SMS and GOES is the Visible and Infrared Spin-Scan Radiometer (VISSR). The VISSR provides concurrent observations in the infrared (IR) (10.5 to 12.5  $\mu\text{m}$ ) and in the visible (VIS) (0.55 to 0.75  $\mu\text{m}$ ) regions of the spectrum. The VISSR provides a full-disk view every 30 minutes. More frequent scanning can be obtained at the expense of spatial coverage. The VIS channel provides 1-km daytime coverage whereas the IR channel provides 8-km daytime and nighttime coverage.

The VISSR data are processed through the NESS Central Data Distribution Facility as a full-disk image or portions of the full disk known as sectors. These images are routed to Satellite Field Services Stations (SFSS's)--located in Washington, D.C.; Miami, FL; Kansas City, MO; San Francisco, CA; Honolulu, HI; and Anchorage, AK--for analysis and further distribution to National Weather Service (NWS) Forecast Offices and other users.

The VISSR instrument images the Earth by step-scanning a portion of the Earth as the satellite spins on its axis. The VIS and IR data for each scan are converted to digital count values on the spacecraft and then transmitted to ground during the Earth-view portion of the spin cycle. The IR data are expressed as 8-bit count values that can be converted to equivalent blackbody temperatures. The VIS data are expressed as 6-bit count values measuring relative brightness. Information is appended to the data that allows it to be located with respect to the Earth's surface. A complete description of this dual-geostationary satellite system can be found in NOAA Technical Memorandum NESS 64<sup>2</sup>.

This paper describes an automated technique that uses VISSR thermal IR data from GOES-East, upper air analysis information, and manually digitized radar data to produce a cloud-top height and radar display at the same projection in near real-time for operational evaluation by the NWS and NESS.

### III. VISSR DATA BASE (VDB)

The digital VISSR data from both the GOES-East and GOES-West are being processed, real time, into an operational VDB and stored on computer disks. The VISSR data are transmitted to the ground acquisition station during the spacecraft's Earth-view portion of the spin cycle at a data rate of 28 megabits/second. During the space-view portion of the spin cycle, the data are quality-controlled; geographic grid data are inserted into the data stream and then retransmitted back to the spacecraft at a slower, 1.7 megabytes/second, data rate. These retransmitted data are known as the stretched VISSR data.

The stretched VISSR data are normally obtained from each satellite at 30-min intervals. About 18 minutes are required for the VISSR to produce the digital image of the full disk, and 12 minutes are required to recycle the stepping mirror. The GOES-West data are normally acquired at 15 minutes and 45 minutes after the hour, while the GOES-East data are acquired on the hour and half hour.

The VDB is formed by real-time processing of the full-resolution, stretched VISSR data (received in Suitland, MD, via two 7-m dish antennas) onto staging disks and then to the NOAA IBM 360/195 computer. From the receiving antenna, data pass through interfacing electronics to the VISSR ingest computer (VIC), known as sectorizers (GTE IS1000

128 kilobytes). The VIC simultaneously writes the stretched VISSR data to one of two 9-track 1600 bpi tapes and to one of two 22-megabyte disks (one for each spacecraft). The 22-megabyte disk is used to stage the stretched VISSR data as it is being acquired. Each disk has a 1-picture capacity (4-km VIS, 8-km IR resolution). At the end of the last full-disk scan and while the VISSR onboard the spacecraft is recycling to the start position for the next picture, the VIC reads back the staged VISSR data from disk one scan line at a time, processes it into a 13,028-byte buffer area, and then transfers the data to the NOAA IBM 360/195 VDB automatically. The VIC buffer area reads back and processes eight scans of 8-km IR data, two scans of 4-km VIS data, and 21 scans of raw navigation data before transmitting to the NOAA IBM 360/195. A full-disk VISSR picture of the Earth contains 1,821 IR scans but only data from 50°N to 50°S and 50° either side of the satellite's subpoint are stored in the VDB. It normally takes about 1.3 minutes after the last scan line of the VISSR to build an 8-km IR picture in the VDB, and 5.5 minutes for an 8-km VIS with an 8-km IR picture, and 7.5 minutes for an 8-km VIS, 8-km IR, 4-km VIS plus raw navigation. If the disk system fails, the VDB data are produced by reading data from the VISSR ingest tape. Depending on the load of the NOAA IBM 360/195, this ingest normally takes one hour. The VIC and 22-megabyte disk used in this way to ingest the VISSR to the VDB are known as the VISSR Data Handling System (VDHS). The VDHS is shown schematically in Figure 1. Depending on the number of types of data being loaded into the VDB for a given picture time (i.e., 8-km IR only or 8-km IR and 8-km VIS, etc.), it can normally be accessed about 8 minutes after the end of the Earth scan or about 26 minutes after picture start time. Such a large and timely digital data source is unique to satellite environmental data processing.

The VDB physically resides on four disk packs (200 megabytes each) that comprise a portion of the NOAA IBM 360/195 computer facility in Suitland. The data are maintained for 24 hours. After 24 hours, a small portion of the data is archived on magnetic tapes (every 3 hours from 0000 GMT from both spacecraft) for the Environmental Data and Information Service (EDIS); the remaining data are overwritten with current data. The current archive of digital VISSR data began in July 1978 and a more limited archive dates from July 1976.

#### IV. CLOUD-TOP HEIGHT AND RADAR PRODUCT

The Applications Division of NESS has developed a cloud-top height display technique that utilizes upper air analysis fields from the National Meteorological Center (NMC) and IR data from the VDB. Computer printer alphanumeric are used to produce a cloud-top height display by converting each VISSR IR 8-km pixel (IR sample) to temperature, then to height, based on the pressure/height/temperature profile at the given location from the NMC upper air analysis field. The computer printer alphanumeric produce a height display at about 8-km spatial resolution and 5,000-ft vertical resolution for heights at or above the 20,000-ft level.

In addition to the cloud-top heights, manually digitized radar storm detection (SD) codes are also extracted from NMC files and mapped at the GOES-East projection. Thus, both cloud-top heights and radar data are made available at the same projection with both observations made at approximately the same time.

The computer program currently extracts IR data from the VDB for the 2100 and 2200 GMT picture times for two areas of approximately 1,000 km on a side. (The two areas being evaluated are centered near Tulsa, OK, and Roanoke, VA.) A height/temperature profile is then computed for each center latitude/longitude position using the latest NMC upper air data. Each IR pixel temperature value is converted to a height value, coded and stored in a printer-compatible file along with the radar observation SD codes of 2135 and 2235 GMT. The cloud-top height coded values and SD radar code are then printed at the World Weather Building in Camp Springs, MD, and the SFSS in Kansas City. A transparency of background geography allows analysts to use both the satellite and radar data coincidentally. An example of these analyzed fields is shown in Figure 2 with the corresponding visible image shown in Figure 3.

This product is one of the initial digital satellite products being considered for development and use on the Automation of Field Operations and Services (AFOS) system of NWS. The product is being evaluated by personnel of the Synoptic Analysis Branch of NESS, the SFSS's in Washington, D.C., and Kansas City, the Techniques Development Unit of the National Severe Storms Forecast Center in Kansas City, and several regional Scientific Services Division offices of the NWS. The test and evaluation began November 1978 and will continue until May

1979.

The timeliness of meteorological data, either conventional or remotely sensed, is of critical importance to an analyst or forecaster responsible for routine forecasts, severe weather forecasts, and warnings. The cloud-top height display with radar SD codes is evaluated for timeliness of product delivery and usefulness of having the digital cloud-top height data and radar data at the same projection. The current product is produced only once a day at 2310 GMT. At that time, data in the VDB are already over two hours old for the 2100 GMT observation. Even though the VDB data are available at about 2125 and 2225 GMT, the SD data are not available at NMC until about 2200 and 2300 GMT. As a result, only the 2200 GMT data are effectively being evaluated for timeliness.

The machine processing of the product for both test areas at the two picture times requires about 13 seconds CPU on the NOAA IBM 360/105 and about 1.5 to 2.5 minutes elapsed time. The computer printer product has encountered significant delays getting to the hands of the analyst since it has to be separated from other operational jobs also being listed at the same time. Although this method of production, delivery, and display seems adequate for the initial test and evaluation of the technique, it would not provide the timeliness needed by NWS/NESS to support weather warning and watch services. For this reason, the product is being tailored for the NWS all-electronic AFOS system. Using the AFOS system to distribute and display the product would certainly improve its timeliness and require virtually no hand analysis of either the radar or cloud-top height data. However, the volume of satellite data to be communicated via AFOS may be too much for the system to handle. Test and evaluation of the AFOS version of the satellite cloud-top height product has not yet begun. Figure 4 is an example of the cloud-top height data displayed on an AFOS CRT. The maximum dimension of satellite cloud-top height data displayable on an AFOS CRT from the VISSR 8-km data is 113 columns by 69 rows, about 900 km horizontally and 600 km vertically, or about a 2-state area. Current software used to generate the AFOS-compatible CRT display adds about 0.9 CPU second for reformatting the product so that it can be transmitted via AFOS. To transmit the product to the AFOS system through the System Monitoring and Control Center in Suitland and then around the National Digital Circuit to all NWS AFOS sites takes about 12 seconds, assuming about 50 percent cloud cover in the area to be displayed. To cover the contiguous United States with

full-resolution, cloud-top height data from the VISSR is estimated to require 25 such overlapping displays. A contoured cloud-top height product and lower resolution displays are being considered for development.

#### V. PRODUCT EVALUATION

At the time of this writing, the product has undergone only preliminary evaluation by analysts and forecasters. Results to date have been encouraging but far from complete. A discussion of results will be given at the presentation of this paper.

#### REFERENCES

1. Dismachek, D. C., "National Environmental Satellite Services Catalog of Products," NOAA Technical Memorandum NESS 88, U.S. Department of Commerce, NESS, Washington, D.C., June 1977, 102 p.
2. Bristor, C. L., Ed., "Central Processing and Analysis of Geostationary Satellite Data," NOAA Technical Memorandum NESS 64, U.S. Department of Commerce, NESS, Washington, D.C., March 1975, 155 p.

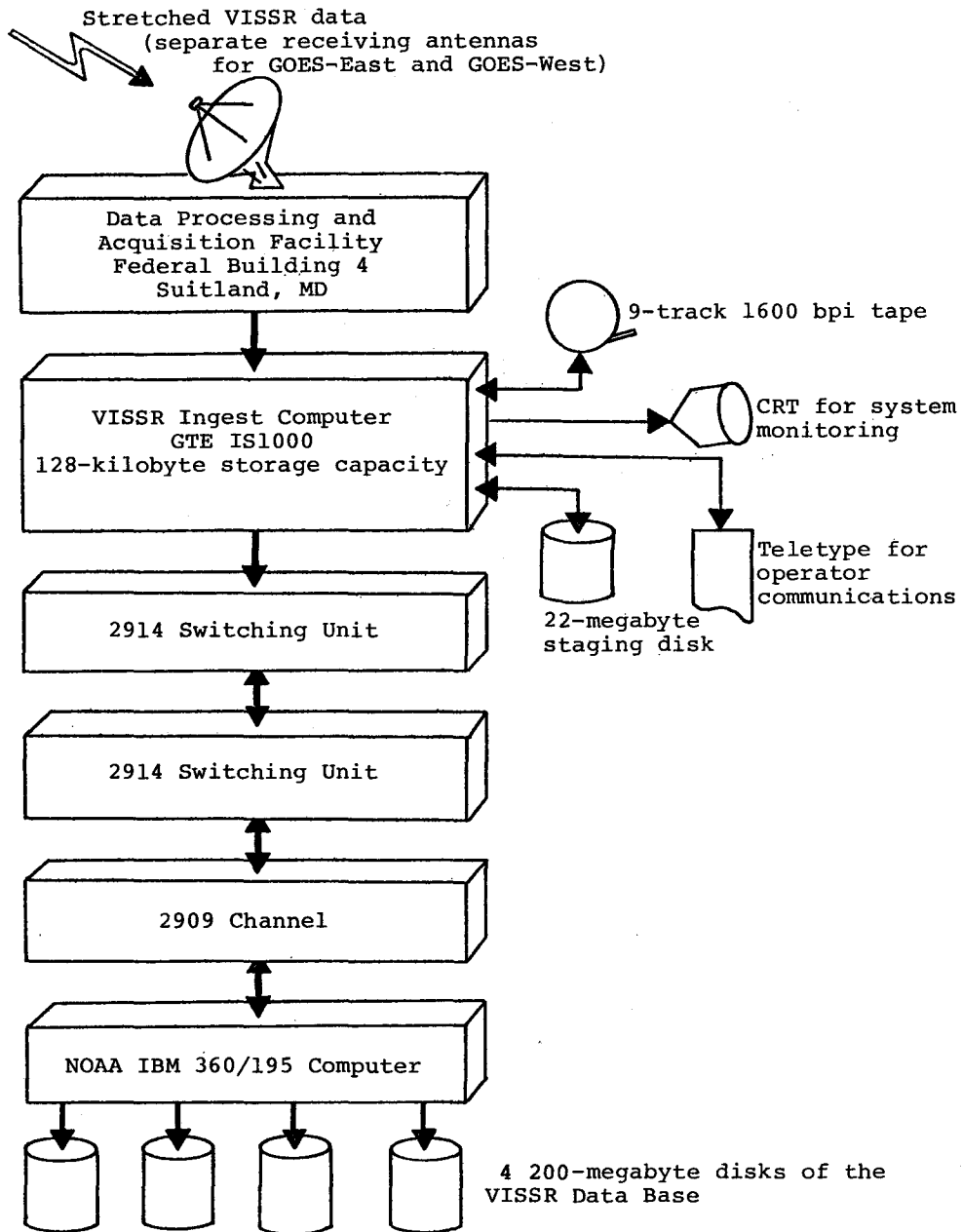

Figure 1. The VISSR Data Handling System used to build the VISSR Data Base. Separate and independent processing of the GOES-East and GOES-West data is handled by separate VISSR ingest computers. Only one data stream is shown.

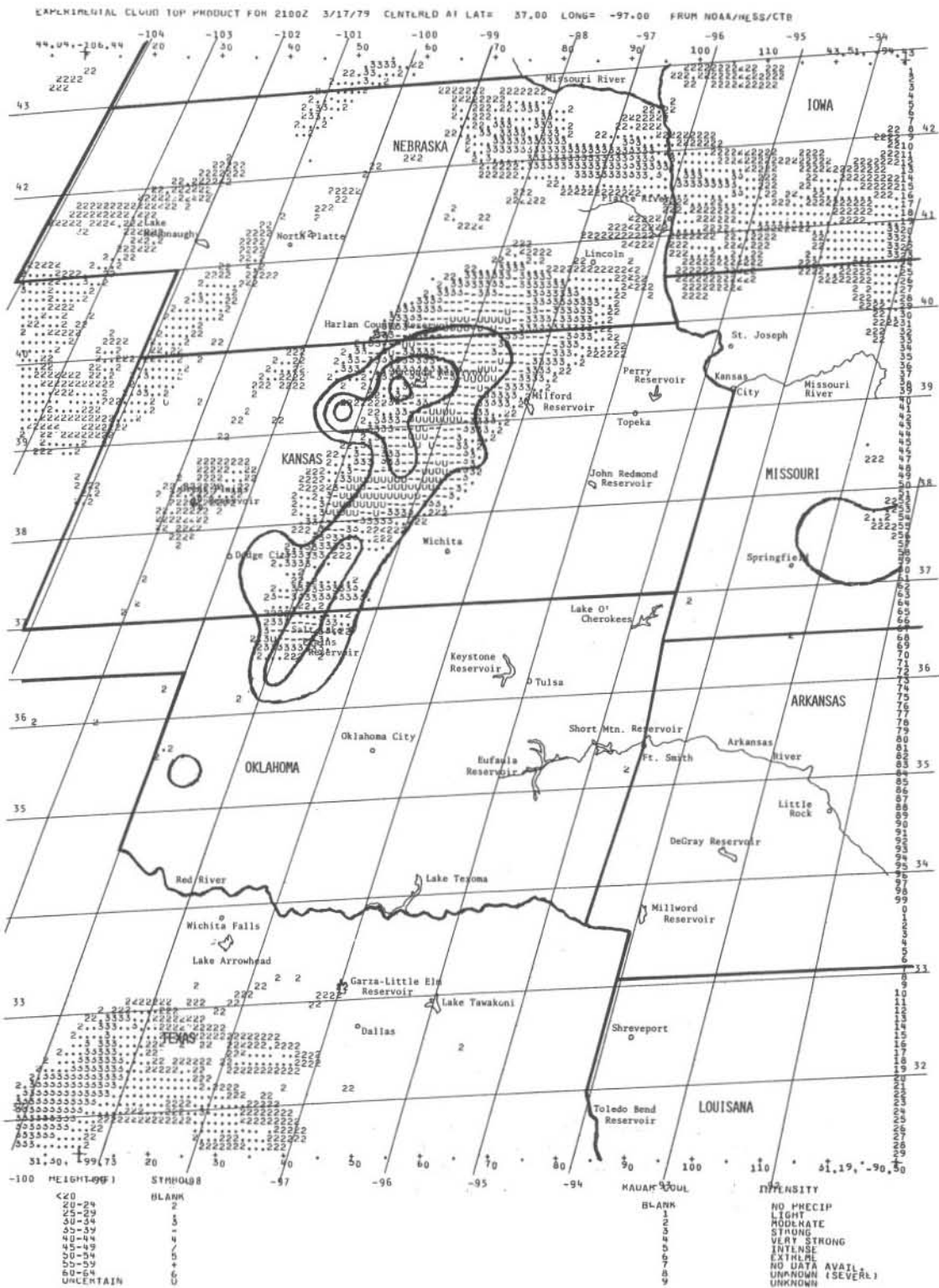

Figure 2. Cloud-top height display from digital IR data taken from GOES-East centered at 37.0N, 97.0W at 2100 GMT on March 17, 1979. Manually digitized radar (SD code) is superimposed and contoured at intensity intervals 1-3-5.



17MR79 11A-1 01783 12393 RA37N102W-A

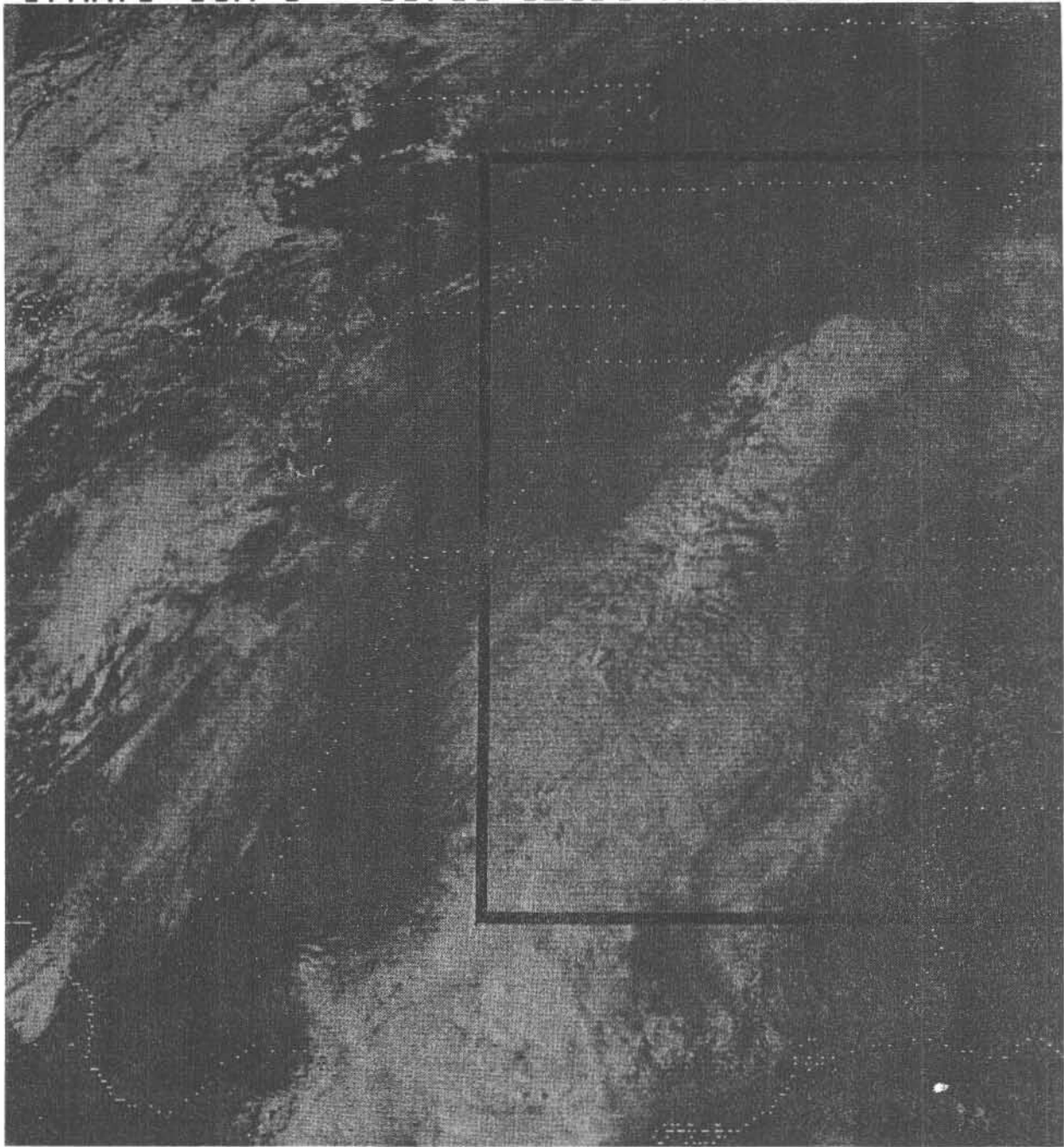

Figure 3. One-kilometer resolution VIS picture taken from GOES-East at 2100 GMT of March 17, 1979, showing bounded test area.



Figure 4. Cloud-top height display from digital IR data taken from GOES-East centered near Wichita, KS, at 2100 GMT of February 7, 1979, as seen on graphics CRT of the AFOS system.