

6-2021

Quantitative Assessment of Sun Louver Design Performance

Alexis Severson

Oklahoma State University, alsever@okstate.edu

Khaled Mansy

Oklahoma State University, khaled.mansy@okstate.edu

Tom Spector

Oklahoma State University, tom.spector@okstate.edu

John Phillips

Oklahoma State University, john.j.phillips@okstate.edu

Jeanne Homer

Oklahoma State University, jeanne.homer@okstate.edu

Follow this and additional works at: <https://scholarworks.umass.edu/btes>



Part of the [Architectural Engineering Commons](#), [Architectural Technology Commons](#), [Construction Engineering and Management Commons](#), [Engineering Education Commons](#), and the [Structural Engineering Commons](#)

Recommended Citation

Severson, Alexis; Mansy, Khaled; Spector, Tom; Phillips, John; and Homer, Jeanne (2021) "Quantitative Assessment of Sun Louver Design Performance," *Building Technology Educator's Society*: Vol. 2021 , Article 10.

DOI: <https://doi.org/10.7275/bhgt-vq57>

Available at: <https://scholarworks.umass.edu/btes/vol2021/iss1/10>

This Paper is brought to you for free and open access by ScholarWorks@UMass Amherst. It has been accepted for inclusion in Building Technology Educator's Society by an authorized editor of ScholarWorks@UMass Amherst. For more information, please contact scholarworks@library.umass.edu.

Quantitative Assessment of Sun Louver Design Performance

 Alexis Severson, Khaled Mansy, Tom Spector, John Phillips, and Jeanne Homer

Oklahoma State University

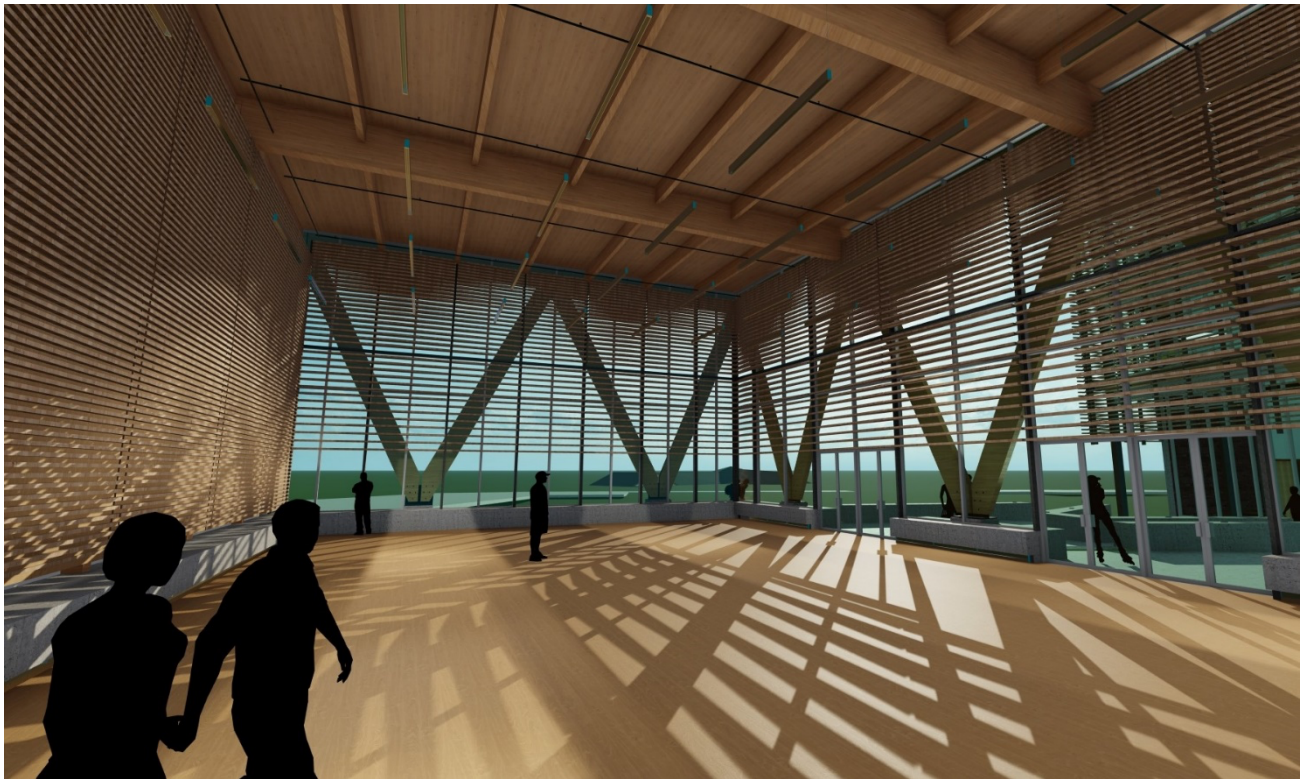

Figure 1. An image of the Multipurpose Space, the inspiration for the research project. The louvers that were tested are along the right side of the image.

Abstract

Conventional wisdom holds that carefully designed exterior louver systems tuned to a building's earth latitude and its glass wall's compass orientations do a better job of regulating sunlight than interior louver systems due to the intuition-friendly observation that exterior systems reflect or shade the sunlight before it ever enters the building. A multi-criteria, multi-variable analysis performed on a 3600 SF multipurpose space came to different conclusions. The results showed that when accounting for such design criteria as carbon footprint, glare, optimal daylighting and solar heat gain of the

interior, tuned exterior louvers perform well against some measures but fared poorly in others, making the decision between types of louver systems a matter of setting performance priorities and aesthetic preference in any given building. This paper summarizes a student's independent research study in which she tested her studio project's arrangement of sun louvers in a large multipurpose space, measuring a number of factors with a goal of determining the best design. Four interdisciplinary faculty collaboratively reviewed her research from architectural, structural, and environmental perspectives. For the analysis, Cove Tool, eQUEST, Tally, and EC3 software were used to test the

performance of various louver layouts. A series of separate studies investigated whether the presence of louvers, their solar orientation, the location of the louvers relative to the glass wall, and louver spacing impacted daylighting and energy performance and carbon footprint reduction. All louver studies were compared to a reference design of exposed non-louvered glass, specified to meet minimum code standards. While some results followed widely accepted logic regarding the design of sun louvers, many differences in performance were either not as dramatic as expected, or positive performance results in one category were offset by negative performance results in another. In the end it is evident in this study that the detailed refinements of ~~were~~ louver design do not dramatically affect daylight, energy, or carbon footprint performance in a way that would provide designers with clear performance directives, in the absence of preset priorities, so such factors as aesthetic intent may ultimately take on a decisive role.

Keywords: Sun Louvers, Carbon Footprint, Daylighting, Energy

Introduction

The design process involves hundreds of small decisions, each based on a number of factors that should be carefully weighed. A lasting trend in architectural design is the layering of sun louvers with glass curtain walls for both aesthetic and functional reasons. Louvers can incorporate meaning into architecture, delight a variety of users, and relate to human scale. They also can reduce glare and heat gain, impact energy use and daylighting levels in a building, and impact carbon footprint. Daylighting and sun louver design involve a balance of these qualitative and quantitative performance factors.

The project used in the study was initially designed in the Comprehensive Design Studio, a studio within the undergraduate curriculum that emphasizes the

integration of systems and performance of design, including daylighting. The project was a community center for homeless youth in Oklahoma City. An important space in the center was a large multipurpose space of 3600 SF which could be used for a variety of activities including exercise, sports, and even fundraising events. As such an important space in the project, the daylighting should be sufficient and uplifting. The multipurpose space was sited prominently within the site and project massing, defining the project's entry courtyard and the first point of interaction with visitors. The multipurpose space had glass curtain walls along two of the sides providing views to a central courtyard that focused on the client and the broader community. To prevent issues with glare and to break up the large expanse of glass, louvers were integrated into the design of the multipurpose space. Because of the overall projects' expressive exterior structural elements, the student made the decision to place the louvers on the interior of the glass, which eventually led to the initial phases of testing. (See Figure 1)

The testing was done in three phases, and operational time was Monday through Friday from 8:00 a.m. until 5:00 p.m. In Phase One of testing, the student set a base design with a curtain wall with glass specified to meet code. As a building within Climate Zone three, the project's vertical fenestration (glass) was required to have a maximum U-value of 0.46. Performance of the curtain wall and curtain wall with louvers were compared using several louver designs of varying physical characteristics, including changes in the placement of the louvers and the orientation of the building. Although the multipurpose space was part of a larger building, it was isolated to focus the scope of the study. Phase Two involved testing refinements to the vertical spacing of the horizontal members. Phase Three then examined the impact of different louver configurations on the carbon footprint of the testing model to test which configuration might perform best overall.

Phase One: Louver Design and Placement

The design intent of the wood louvers was to incorporate the timber structural and wood materials used throughout the community center and to relate it to a human scale in the large multipurpose space. The louvers that were tested were simplified, fully rectangular members, as that afforded greater ease of model variation and testing than the originals, which varied in width along their overall length. (See Figure 2) The louver screen was designed with 2 x 6 pieces of western red cedar, steel angles, and rectangular HSS columns. The louvers covered the entire expanse of the wall (roughly 73.5 feet). The vertical supports of the system were anchored structurally to an interior bench and the roof, and were roughly 26.5 feet in height, while the horizontal louvers started near the ceiling and continued downward to the top of the exterior doors, with a height of around 20.5 feet, measured from the ceiling. The vertical spacing of the louver system varied from top to bottom, starting at four inches toward the ceiling, and ending at nine inches at the bottom. Isolated from its original context and redesigned as a simpler but flexible design, the louver screen is an efficient and constructible model that can be adjusted for many vertical spacing configurations, enabling the testing to optimize for daylighting, glare, and efficiency in any orientation. Standard curtain walls can be used because the louvers were designed as a self-supporting system.

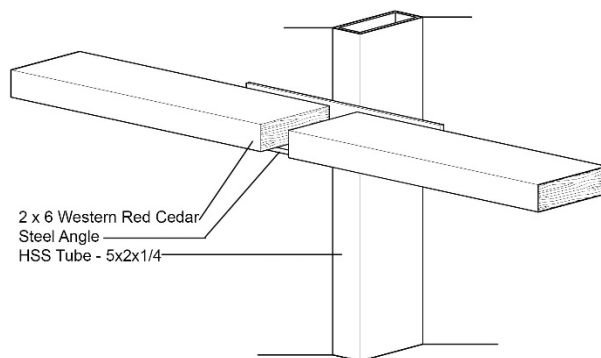

Figure 2. An Axon of the Shading Screen Connection

After the louver base design to be tested was determined, options were tested to determine whether louvers were needed, which solar orientations benefitted from the presence of louvers, and whether the louvers were more effective on the interior or exterior of the curtain wall. Using the Website/Revit Plug-in called cove.tool, the performance tests included the sDA (Spatial Daylight Autonomy), ASE (Annual Solar Exposure), EUI (Energy Use Index), number of LEED points, and the percentage of CO₂ reduction. Cove.tool is an automated performance analysis software that enables the designer to test various environmental aspects of their building, especially in regards to the performance tests listed above.

Spatial Daylight Autonomy (sDA) describes the percentage of a space that gets at least 300 Lux for 50% of its annual occupied hours, with an average of 55% required in order to qualify for LEED points. The higher the sDA, the less electric lighting is needed. Annual Solar Exposure (ASE) is the percentage of the space that gets too much direct sunlight which is generally calculated at 1000 Lux or greater for at least 250 occupied hours per year. ASE should be minimized, as it reveals potential negative impacts of daylight including glare or heat gain. In order to qualify for LEED points, the ASE of a project should not exceed 10%, a difficult percentage to achieve. In comparison, the Energy Use Index (EUI) measures the energy required to operate and sustain a building during occupation and amounts are compared to buildings of similar use and against 2030 performance goals. Units are energy per square foot per year (kBtu/ft²/yr.).ⁱ

The familiar rating system of Leadership in Energy and Environmental Design (LEED), a far broader category than the sDA or ASE, provides a framework for healthy, efficient, & cost-saving “green” buildings. Points on different tiers are earned through the implementation of various green building strategies. The four tiers are: Certified (40-49), Silver (50-59), Gold (60-79), and Platinum (80 and beyond).ⁱⁱ The final result category, CO₂

Reduction, is the percent reduction of carbon emissions a building has in a year. Results are compared to the carbon emission standards set by the 2030 baseline by taking a ratio of the building's emissions to the 2030 baseline, generating a percentage.ⁱⁱⁱ

To test solar orientation, the plan was rotated counter-clockwise through eight different 45-degree intervals, starting at directly east (designated as 0 degrees) and ending at 315 degrees (southeast). In addition, each orientation featured three different louver options—one without the louver screen to act as a control base design, one with the louver placed on the interior of the glass, and one with the louvers on the exterior.

After testing with *cove.tool*, the process was repeated in the energy modeling program *eQUEST*. As a program, *eQUEST* enables the designer to get exact heating, cooling, and daylighting loads using a simplified model of their project. The program generates multiple pages of results, however, the results most relevant to the research were the peak heating and cooling loads, as well as the average daylight illuminance per month of the space. There were 48 models tested in all. (See Figures 3 and 4)

After Phase One testing in *cove.tool* and *eQUEST*, it was clear that adding the louver screen, regardless of its placement on the interior or exterior of the glass, improved daylight performance for every orientation, with the exception of due North (90 degrees), as daylight coming from the North is indirect. Compared to the control base curtain wall without louvers, the models with a louver screen reduced ASE in every orientation by almost 20% (North) to around 70% (East). As certain orientations, such as those in a Southern direction (225, 270, and 315 degrees), have higher amounts of both daylight and glare, the fact that the louvers could decrease the ASE by a reasonably high percentage is important. This shows the designer that the louver design would enable them to orient their glass facades in almost

any direction without worrying about undue amounts of glare. Overall, however, the presence of louvers dramatically reduced the sDA performance and LEED points to below desired levels recommended by *cove.tool*.

Another conclusive result was that in all solar orientations, placing the louvers on the exterior of the curtain wall performed better than the control model with code compliant glass only. The exterior placement not only significantly lowered levels of glare, it also showed consistently lower peak cooling loads than either of the two other options tested, though there are no large differences in peak heating loads. These results demonstrated that adding louvers to the design not only provided aesthetic value, they also worked to make aspects of the wall and building performance more efficient.

However, the results of performance tests on interior louvers were similar to those of the exterior louvers; interior louvers performed just one or two percentage points lower than exterior louvers in *cove.tool*. Since interior louvers do not have to withstand wind loading and weathering, they have the added advantage of entailing predictably lower embodied carbon compared to exterior louvers and reduced maintenance costs.

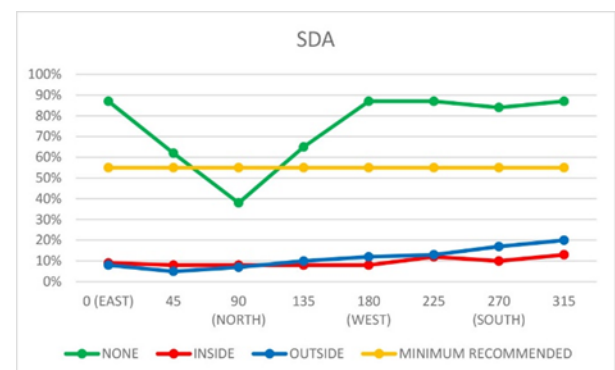

Figure 3. Phase One *cove.tool* testing results

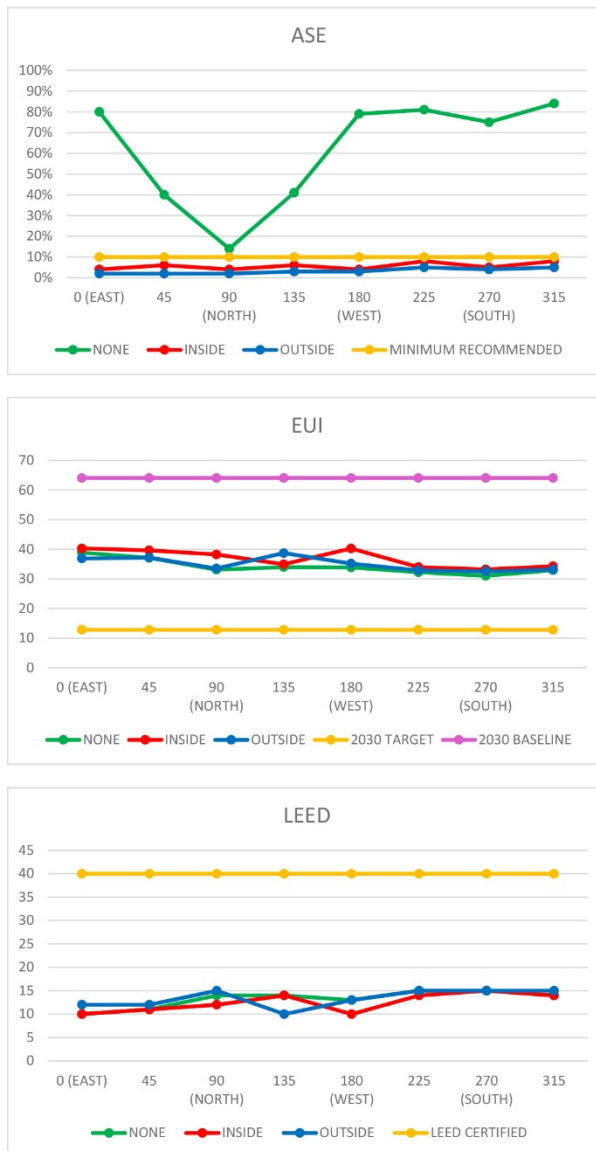

Figure 3, cont. Phase One cov.e.tool testing results.
sDA: Both inside and outside louver options resulted in much lower levels of daylighting than the option with no louvers and much lower than recommended glare levels.
ASE: Much like the *sDA* results, the two options with louvers inside and outside had much lower levels of glare than the option without any louvers. In this case, all louvers performed better than recommended glare levels.
EUI: This result is based on the whole building and system design. The three options tested had fairly similar results, and all performed worse than the 2030 target but better than the 2030 baseline. Louvers did not have much of an impact on *EUI* levels.
LEED: While none of the options tested came close to becoming LEED certified, there were a few variations among the three of them, depending on the orientation.



Fig 4. The peak heating and cooling load results from eQUEST. *Cooling Load*: While the inside and no louver options had similar results, the outside option reduced the peak cooling load for each orientation tested by half. *Heating load*: All three options performed similarly. Having louvers did not impact the heating load.

Phase Two: Louver Spacing

If the differences between inside and outside placement of the louvers are negligible, and all louvers lower the *sDA* and *ASE* percentages, then perhaps the actual spacing of the louvers was a more important determinant. The next series of tests focused on three different equally-spaced versions of the louvers, all placed on the outside of the glass, since it was determined to be the best performing option from Phase One in terms of *sDA*. The three spacing intervals chosen for the tests were all based on an initial module of four inches, which was chosen as the smallest, followed by eight inches, then sixteen inches. Other than the changes made to the louver spacing, the remaining variables remained the same. The model was again rotated through the same

eight orientations as the previous test. Because eQUEST as a whole produces models that are too generalized to properly test more detailed differences such as louver spacing adjustments, cove.tool was used for Phase Two testing. In total, 24 models were tested during this phase.

The compilation of all the results into a spreadsheet (fig. 4) revealed that certain variables impacted the performance of the louver positively in one category, but not in others. (See Figure 4) For example, the largest spacing, 16 inches, performed the best in sDA, for all orientations, including north (90 degrees), with an average of 68%, exceeding the minimum percentage of 55%. However, it was the worst in ASE percentage with an estimated average of 50%. Inversely, of all the options tested, the 4-inch spacing performed the worst in sDA, only meeting or exceeding the 55% minimum in 5 of the 8 orientations. When comparing the options using ASE performance, the four-inch spacing performed the best, letting in the least amount of glare, though none of the options met the 10% maximum allowable glare across all eight orientations. Thus, the trade-off between daylighting, sDA and glare, ASE, reveals an important reason behind the difficulty in prescribing louver systems: with more daylight comes more glare and heat gain.

In the EUI results, all of the tested options – 4 inches, 8 inches, and 16 inches, had similar results, especially in the 90 (north), 135, 180 (west), and 225-degree orientations. As the overall goal of EUI is to have as low a value as possible, the 16-inch spacing performed the best, though only by a few points, and only in four of the orientations, leading the student to conclude that any of the spacings are equally acceptable or unacceptable for reducing energy use, at least in this climate.

LEED points, as a decision criterion, were similarly unhelpful. None of the spacing options generated enough LEED points – 40 – to be considered LEED certified. All of the options generated very similar results, especially across the 90 (north), 135, and 180 (west) degree

orientations. The most LEED points generated belonged to the 16-inch spacing, with an average of 15, though the other two options were within 5 points of that value, at 14 and 13 for the 8-inch and 4-inch spacing, respectively. This again proves that while it is beneficial to add a louver system to the project, the details of the system, such as the spacing, cannot be chosen based off of these quantitative results alone.

In addition to sDA, ASE, EUI, and LEED, carbon dioxide reduction was tested in cove.tool. CO₂ reduction tests showed consistent results among the options in the 90- (north), 135-, 180- (west), and 225-degree orientations. None of the options tested had a higher reduction than 35%, with the 8-inch spacing having the lowest values in the 0 (east) and 45-degree orientations, while the 4-inch option performed the worst in the 270 (south) and 315-degree orientations. The 16-inch spacing had the most consistent set of results.

When compared to the previous phase of testing, which used the base design for the louvers, all of the exterior spacing options tested had higher (therefore, better) sDA performance than the Part One outside option, regardless of orientation. The outside option did have lower ASE percentages better than any of the spacing options, though the 4-in option came the closest.

All of the spacing options tested improve the original shading screen's design, though only in certain categories. Of the three options, there is no clear winner, as they all perform better in different categories. Which spacing option is the best very much depends upon which factor the designer considers more heavily when making decisions, making it difficult once again to determine an answer based on factual results alone.

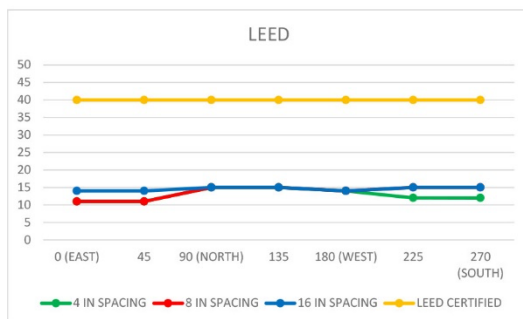
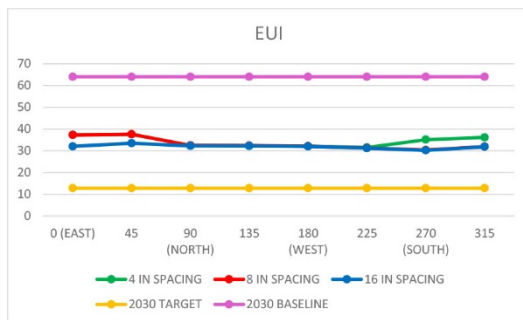
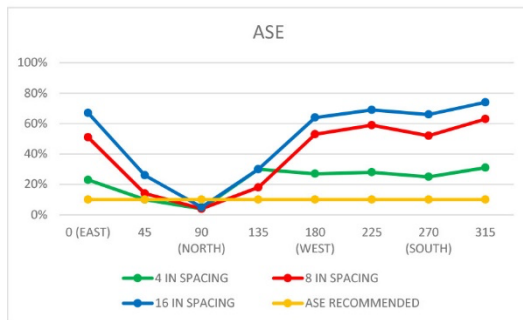
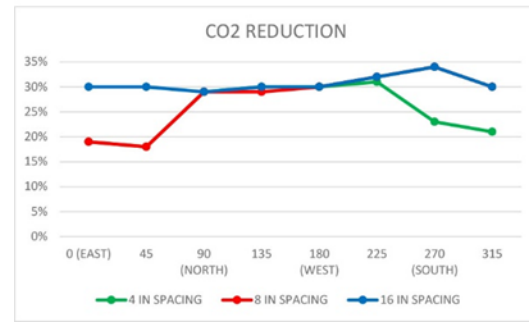
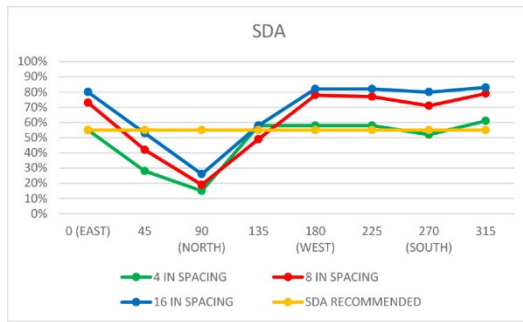

Figure 5. The spacing test results of Phase Two
sDA: Of the three options tested, the 16-inch spacing let in the most daylight and exceeded the recommended percentage in 6 of the 8 orientations tested.
ASE: The 4-inch spacing let in the least amount of glare, but it overall failed to meet the recommended ASE percentage.
EUI: Much like phase one, all three options performed very similarly: better than the 2030 baseline but worse than the 2030 target.
LEED: All three options performed very similarly, lower than LEED certification levels.
CO2 REDUCTION: Of the three options tested, the 16-inch spacing consistently reduced the most CO2, averaging around 30% across each of the tested orientations.

It was also interesting how the EUI was affected by the changes in spacing--the difference in some cases was only a couple of decimal points, but in others it was much greater.

Phase Three: The Carbon Footprint

Since the performance difference between interior and exterior shading devices is negligible, and differences in louver spacing results in distinct trade-offs, the student investigated in Phase Three whether the carbon footprint of the various options would be an influential determinant. Using models created during parts one and two of testing, the Revit Plug-in Tally was used to examine the carbon footprint of five different louver options, selected for their marked differences from one another, as they represent the different extremes of the designed options tested: no screen (none) an interior louver screen (inside), an exterior louver screen (outside), exterior with 4-inch spacing (outside - 4 in spacing), and exterior with 16-inch spacing (outside - 16 in spacing). While Tally is not a difficult program to use, it does require detailed

assemblies for each part of a project; in order to evaluate the carbon footprint, values from a database need to be assigned to each Revit component. Each test produced results in four categories: Life Cycle Stage, CSI Division, Building Element, and Revit Material. An example of one of these results is shown in Figure 5.

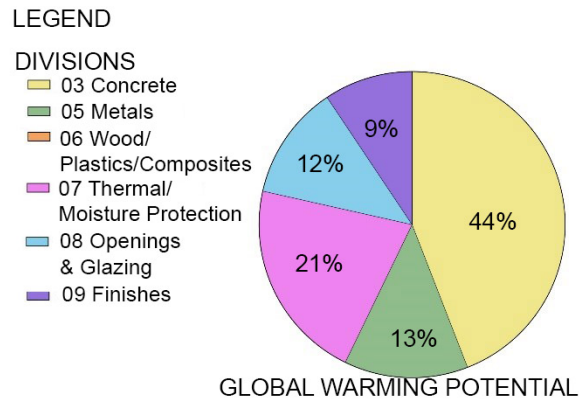

Figure 6. The results per CSI division for the option with the screen on the interior.

Testing the carbon footprint with Tally required careful attention to detail, as every decision had to be identical across all five tests in order to produce accurate results. Aside from the sheer number of decisions to be made, the plug-in was relatively user-friendly, and it was easy to essentially copy and paste material choices across different Revit assemblies within the same file, facilitating the process once the first decisions were made.

Every choice was compiled within a single spreadsheet that was continuously referenced throughout the process in order to ensure identical Tally assemblies, with the only difference as the existence of louvers, the placement of the louvers inside or outside, and the spacing of the louvers within the screen.

Each Tally file was also exported to EC3, another program that looks at the carbon footprint of buildings. As all of the decisions had already been made in Tally, a minimal amount of additional work was needed to generate results in the form of proportional diagrams

showing the total mass and the total embodied carbon of each option tested.

The results gathered from Tally were not as cut-and-dry as what had been expected. For example, the assumption was that the None (no louvers) option would have the lowest carbon footprint across the board, regardless of category, because it required less steel and wood due to the lack of the louver system. Instead, in some of the result categories, the None option had the highest carbon footprint out of all the models tested.

The main consistency between all of the options tested was that the operational energy of the building took up the largest amount of the carbon footprint, more than any other part of the Life Cycle Analysis. This shows that choosing highly efficient systems for basic building functions such as heating and cooling is perhaps more important for determining the overall Carbon Footprint of an option than anything to do with minute differences in louver screen design. That being said, a well-designed screen blocks excess heat and glare, lowering the need for excessive cooling.

The pie charts Tally generates also show marked differences between all of the tested options and their results. Though the total carbon footprint for an option does not change dramatically from result category to result category, the proportions of each part to the whole do. For example, one result category dealt only with the carbon footprint of general building elements: substructure, superstructure, enclosure, and undefined. These larger building elements lump together the more specific results found in the other categories, making it difficult to get a comprehensive understanding of the option tested based on one result alone, as there is no single comprehensive chart that shows decisive results from every single category.

The graphics generated from EC3 for each option were incredibly similar to each other, with only the smallest of

differences between the None option and the options with louver screens. What was consistent across all of the EC3 tests, as well as the results from Tally, was the high impact concrete has on the overall Carbon Footprint of each option, a result irrelevant to louver design.

The carbon footprint of a building project involves a complex equation of variables such as material choices and how far each material must be transported to the project site, the location and context of a project, how it is constructed, and the environmental systems chosen, and a definitive answer is not always reached. It can be difficult to base something as specific as facade design solely on carbon footprint alone--there are just too many variables at play to make any sort of concrete decision.

With all of this in mind, the results among the louver shading screen options were different enough that it did have some impact on carbon footprint, though whether one option should be used over another depends on the priorities of the designer.

Conclusions

Using analytical software cove.tool and eQUEST, initial tests revealed that louvers improved the energy performance over exposed glass, and the placement of louvers on the exterior of the glass reduced the peak cooling load and annual solar exposure (ASE) related to glare, but louvers also reduced spatial daylight autonomy (sDA), which a designer wants to maximize. Overall, however, the differences among placements of the louvers on the exterior of the glass versus on the interior were minimal. Minimal differences were also found testing different louver spacings. Spacing variations of the louvers revealed that the larger the spacing, the

higher the sDA and ASE percentages, and the smaller the spacing, the lower the sDA and ASE percentages. Louver spacing produced mixed results: though certain options performed better in one category, they failed to meet the minimum requirements in others, especially in ASE. There was no clear choice that performed well in all tests, including operational energy use, so ultimately a design decision must be made based on the performance and aesthetic criteria most important to the designer. Finally, five of the leading louver arrangements were tested for their carbon footprint using Tally and EC3 software. The most dominant factor impacting carbon footprint was operational energy, and although louvers can reduce glare and heat gain to reduce cooling load, choosing an efficient system for heating and cooling the building has more significant impact on this number.

In pursuing this research project, the original goal was to find a collection of highest performing design directives for the architect. Many tests later, it is apparent that in terms of daylighting performance and carbon footprint, there is no clear answer, but results challenged time-honored assumptions about louver design, including that louvers should be placed on the exterior of the curtain wall, that louver configuration should change significantly with different orientations, and that the architect's default option should be using louvers over a curtain wall.

So for the architect, once a decision is made to use wood louver screens, aesthetic options can be maximized and explored, knowing in general that the louvers will positively impact ASE, negatively impact sDA, but not impact EUI or carbon footprint dramatically.

ⁱ Cove.tool. Aguirre, Marco, "Energy Use and EUI: Understanding the Terminology." Cove.tool Energy, 12 July, 2021, <http://help.covetool.com/en/articles/2499676-energy-use-and-eui>

ⁱⁱ USGBC, "LEED." Accessed July 15, 2021, <https://www.usgbc.org/leed>

ⁱⁱⁱ Architecture 2030, "The 2030 Challenge." Accessed July 15, 2021, https://architecture2030.org/2030_challenges/2030-challenge/