



A mixed analog/digital shaper for the LHCb preshower

G. Bohner, R. Cornat, Alain Falvard, J. Lecoq, J.Y. Maulat, Pascal Perret, C. Trouilleau

► To cite this version:

G. Bohner, R. Cornat, Alain Falvard, J. Lecoq, J.Y. Maulat, et al.. A mixed analog/digital shaper for the LHCb preshower. Workshop on Electronics for LHC Experiments 5, Sep 1999, Snowmass, United States. pp.274-278, 1999. <in2p3-00011587>

HAL Id: in2p3-00011587

<http://hal.in2p3.fr/in2p3-00011587>

Submitted on 14 Feb 2000

HAL is a multi-disciplinary open access archive for the deposit and dissemination of scientific research documents, whether they are published or not. The documents may come from teaching and research institutions in France or abroad, or from public or private research centers.

L'archive ouverte pluridisciplinaire **HAL**, est destinée au dépôt et à la diffusion de documents scientifiques de niveau recherche, publiés ou non, émanant des établissements d'enseignement et de recherche français ou étrangers, des laboratoires publics ou privés.

A mixed analog/digital shaper for the LHCb Preshower

G rard Bohner, R mi Cornat, Alain Falvard, Jacques Lecoq,
Jean-Yves Maulat, Pascal Perret, Cyrille Trouilleau
Laboratoire de Physique Corpusculaire, Clermont-Ferrand
Universit  Blaise Pascal, IN2P3-CNRS
F-63177 AUBIERE Cedex, France
bohner@clermont.in2p3.fr

ABSTRACT

This note describes, first, the experimental and theoretical studies of the LHCb's preshower signals performed with a prototype cell. Four designs of the very front end electronic are then discussed and a choice is proposed.

1 INTRODUCTION

Figures 2 and 1 show the results of the experimental study of the LHCb preshower signal, produced by a minimum ionisation particle (MIP). At this very low energy, dominant effects on the shape are the statistical fluctuations of the photoelectron collection and of the PM gain, so that the signal shape is quite unpredictable. As we have to handle energy down to 5 MIP's with a 0,20 MIP accuracy, we have to take care of this effect. The important points for the following are :

- the fraction of the energy collected during a LHC beam crossing time (25ns) which is found to be $83\% \pm 10\%$ for a MIP signal;
- the error due to fluctuation of the signal itself decrease to 4% for a 5 MIP's signal, corresponding to our trigger threshold;
- the shape fluctuation decreases when the energy increases and becomes negligible at large energy;
- the comparison between experimental data and a simulation is quite good, except about the little secondary signal (figure 1) at 60ns which is due to a cable reflection in our test set-up.

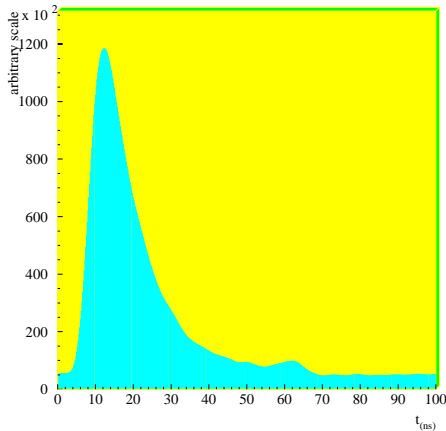

Figure 1: 1000 cosmic events summation

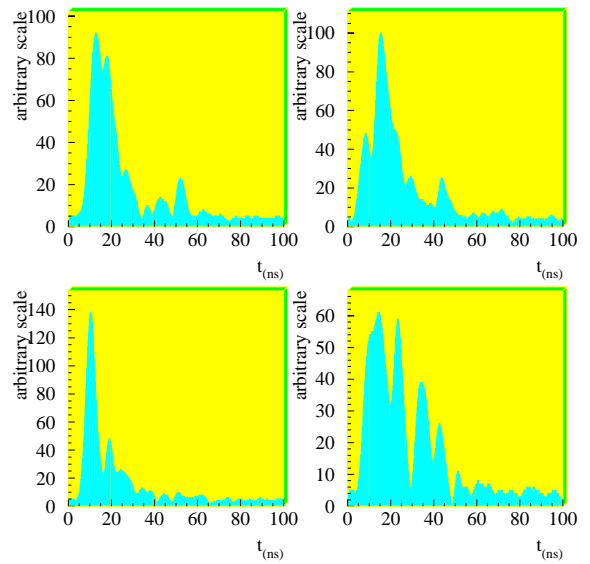

Figure 2: cosmic events

2 ELECTRONIC FUNCTION

As for all the LHC experiences, the frequency of the signals is 40MHz. The number of channels is 6 000, the criterium of cost is decisive. Due to the fact that the signal shape is not constant and the duration greater than 25ns, we have to develop a specific electronic.

The readout electronic of the preshower has two different functions: the trigger and the correction of the energy measured in the calorimeter. Moreover, it takes part in the calibration of the detector.

The 4% resolution of a 5 MIP's signal is precisely the size of the LSB set at 1/5 MIP which should be used as indicated below.

The energy collected in the preshower is a very low

part of the total energy collected by the calorimeter for an electron. It is so necessary to measure it to correct the value observed in the main part of the calorimeter. This is for all the dynamic of the signal. At the moment the maximum energy for an electron of 200Gev is 500 MIP's. The minimal dynamic of the signal is about $5 \times 500 = 2500$. It corresponds to 12 bits. The required accuracy is 1%, corresponding to 7 bits.

We plan to use a 64 channels multianode PM tube. We know that there's some difference of gain between the 64 channels of the PM with a factor as large as 4. The precise studies of these variations remain to be done.

If the first electronic stage is more than 10cm away from the P.M., the signal should be carried on a suitable, carefully adaptable cable. In this case the PM gain correction has to be included in the electronic dynamic range (14 bits).

So we prefer to include the first electronic stages closer to PM tube (the 64 channels); the gain correction can be made very easily by changing the load resistor of each channel and for each PM tube. This advantage involve to have a compact layout including the PM tube and the associated electronic. This electronic will have to include all or just a part of the readout electronic.

3 BASIC CHOICE FOR THE READOUT ELECTRONIC

Two decisive arguments suggest integrating the signal and not only considering its maximum value. On the one hand, we have only an absolute time at our disposal which prevents us to measure the signal at its maximum value, because of its jitter. On the other hand, for the low energy signals, the shape isn't reproducible at all and the integration permit a statistic "pseudo-addition" even for signals of few MIPs.

We have to accept an inaccuracy of one nanosecond when we consider the integration time. To obtain the best precision of the electronic system, the integration time must be as long as possible. The maximum integration time is 25ns since the probability to have two interesting consecutive signals is high. So to integrate the signal during 25ns and then to reset it, we need two bunch crossing. The frequency is divided by two and we have to use two interleaved integrators and one multiplexer by channel which don't raise a lot the price of the system.

As this shaping includes both analog and digital signals we decide to design it in a fully differential way.

We had to design a switched integrator able to come back to ground and with an adequately short integration time at this frequency. This integrator is full differential. It is made from an amplifier with high gain and large bandwidth. To provide a good reset, the differential inputs and outputs are short-circuited with the ground by CMOS switches, as shown on figure 3.

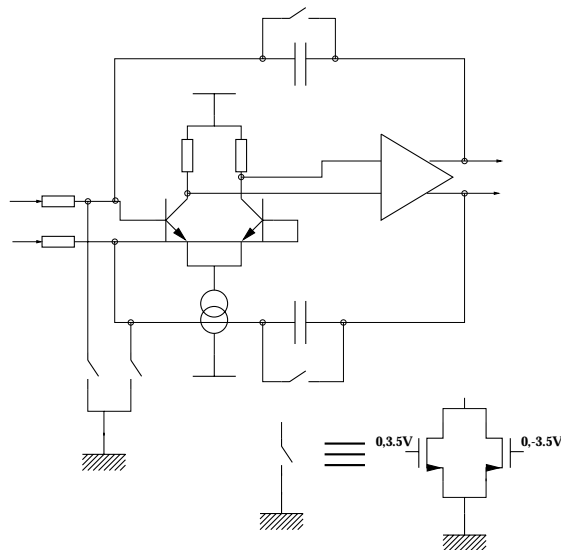

Figure 3: integrator principle

In each design, there's a multiplexing at the output. Here, we choose a differential multiplexer which selects the channel by the switched on off the current generator supplying the selected differential stage, see figure 4.

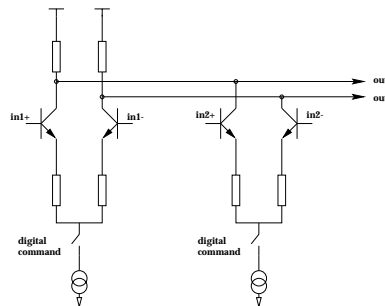

Figure 4: multiplexer principle

The physic signal duration is higher than the bunch crossing period (≈ 70 ns compared to 25ns). To avoid false data and wrong trigger action, there

are two solutions :

1. Erase the data of the periods $n+1$ and $n+2$ if we consider the period n .
2. Measure the collected energy in the preshower with a sufficient precision during the period $n+1$ and $n+2$ and treat the signal with these two results. As in LHCb the probability to have two consecutive signals is not negligible, the solution 1 is excluded.

First of all, we consider that the electronic signals for the period n , $n+1$ and $n+2$, for a signal without pile-up, are proportional with a coefficient α of the order of 15%.

So we have :

$$\text{energie } n = (\text{integrate } n) - \alpha \times (\text{integrate } n - 1)$$

With more precision, α is different according to the circumstances. The α of the period $n+2$ is a little smaller than the α of the period $n+1$. We propose to take the value of α for the period $n+1$ into account. We have obviously a small error when we compute the energy during the period $n+2$. The result is that we loose some triggers during the period $n+2$. Nevertheless, we avoid wrong trigger actions. We will have to measure exactly the effects of this method and check its efficiency. Afterwards, we will have to correct off line the data during this period $n+2$. This point must be discussed according to the tests and the simulations.

4 BASIC DESIGNS

There are mainly four designs with subtraction analogic or digital, with one or two gains.

The first one uses analog subtraction and one gain. We store the integrated value on 25ns in a track and hold, and this value during a second period of 25ns with a second track and hold, at this moment the second track and hold give the value n and the first one give the value $n-1$. Each amplifier subtract the value $n-1$ from the value n , with two different gains (1 and α). At the output of the multiplexer, during a period of 25ns, we have a value corresponding to 83% of the energy collected by the preshower cell during the pevious period. This value is analog and can be digitalyzed with an ADC, see figure 5.

The second one uses analog subtraction and two gains. The same as the last, but we add a gain system, see figure 6.

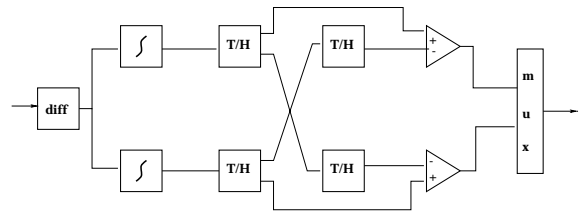

Figure 5: the first design

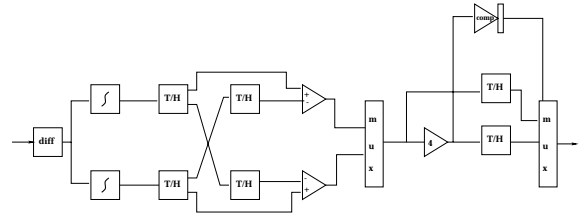

Figure 6: the second design

The third one uses digital subtraction and two gains. It's the basic choice twice copied, see figure 7.

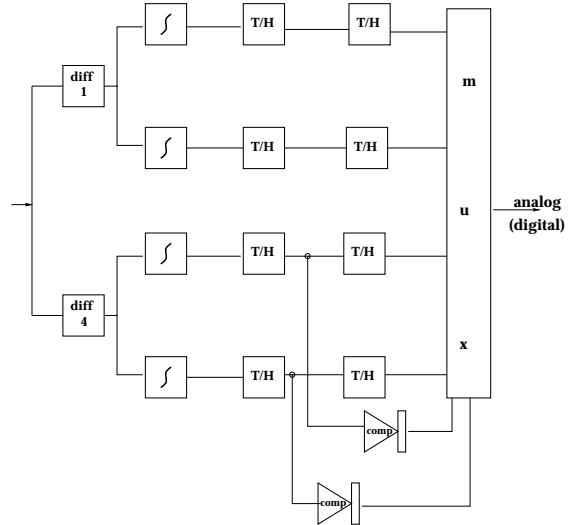

Figure 7: the third design

5 THE MAIN CHOICE

The choice is one gain and digital subtraction. In fact if the subtraction is analog, the α coefficient is a hardware implementation: it's dangerous to choose now this solution because it will be impossible to correct this coefficient. We prefer a digital subtraction to correct precisely the α coefficient by software. One gain is probably sufficient, if two gains are necessary we use the solution of figure7.

The first part is near the detector. see figure 8. There are :

- a first stage to transform common mode to differential mode;
- 2 parallel integrators, one for the bunch-crossing n and another one for the bunch crossing $n + 1$;
- 2 T/H and a 20MHz multiplexer;
- and a buffer to drive a 100 Ω twisted pair.

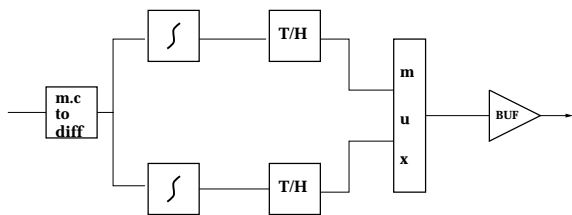

Figure 8: the first part

The second part is at 10m length from the detector cell, see figure 9 :

- a commercial 12 bits converter;
- a digital stage with :
 - a look-up tables for gains and pedestal
 - a converter to a good numerical format, probably 9 or 10bits (floating point)
 - the weighted subtraction
 - the trigger output with a digital comparator (the precise threshold value is adjusted by software).
- a memory to wait the L1 trigger decision and to send the value to the DAQ.

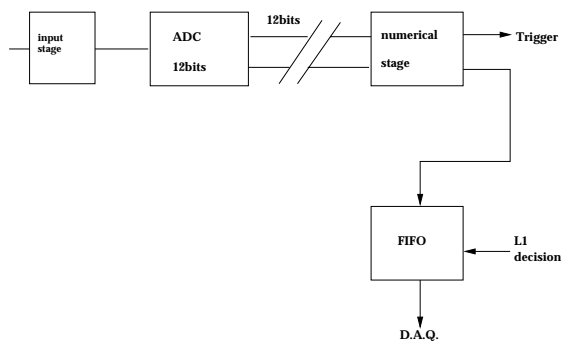

Figure 9: the second part

The first chip, in BiCMOS 0.8 μm technology by AMS has been sent in january. In this, there are : an integrator and a T/H, and a channel with the common mode to differential mode translator, an integrator, a T/H and a clock generator. A second chip was sent in april with a full channel with two gains without subtraction.

6 TEST RESULTS

The first chip is fully tested. The track and hold works very well, in fact a little better than pre-

dicted in simulation. Its dynamic is good and its linearity is found better than 1%, which is the precision of our measurement, see figure 10.

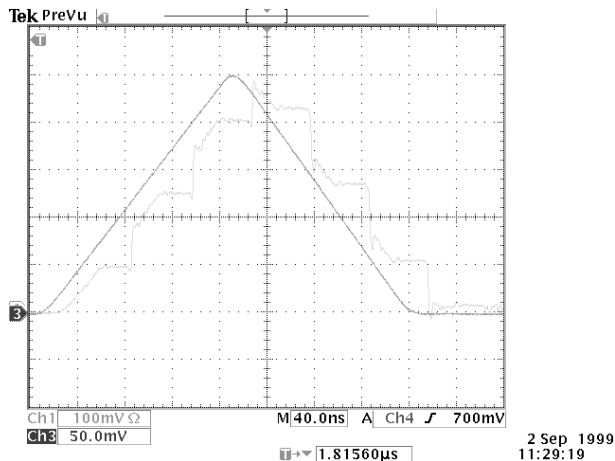

Figure 10: scope reproduction

The clock generator and the input stage which realise the conversion to the differential mode are also working well. The surprise comes with the switched integrator itself which shows a parasitic oscillation (see figure 11). We try to reproduce this oscillation in simulation by retroannotate everything including the test environment. We don't succeed. We measure the gain, it is correct and the reset time is also correct.

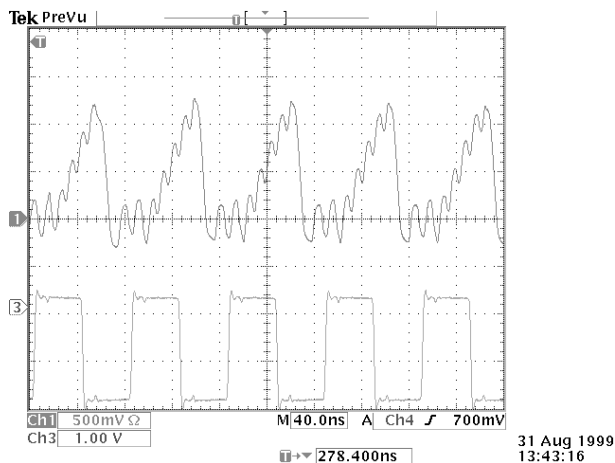

Figure 11: scope reproduction

As all the other cells show better performance than predicted, we think (without proof) that the open loop gain of the operational amplifier is too large. Another design, with a lower gain, was sent to AMS foundry.

The second chip is under test. The integrator is the same and is also unstable, but by decreasing externally its current source to reduce the gain, we obtain a stability sufficient to test the full chip functionality. We will do these test soon.

7 CONCLUSIONS

A mixed analog-digital shaper included T/H was designed for the LHCb preshower. Every functions are working except an oscillation on the integrator. A new integrator design was sent to AMS foundry in september. A full chip and test bench is expected by the end of 2000.

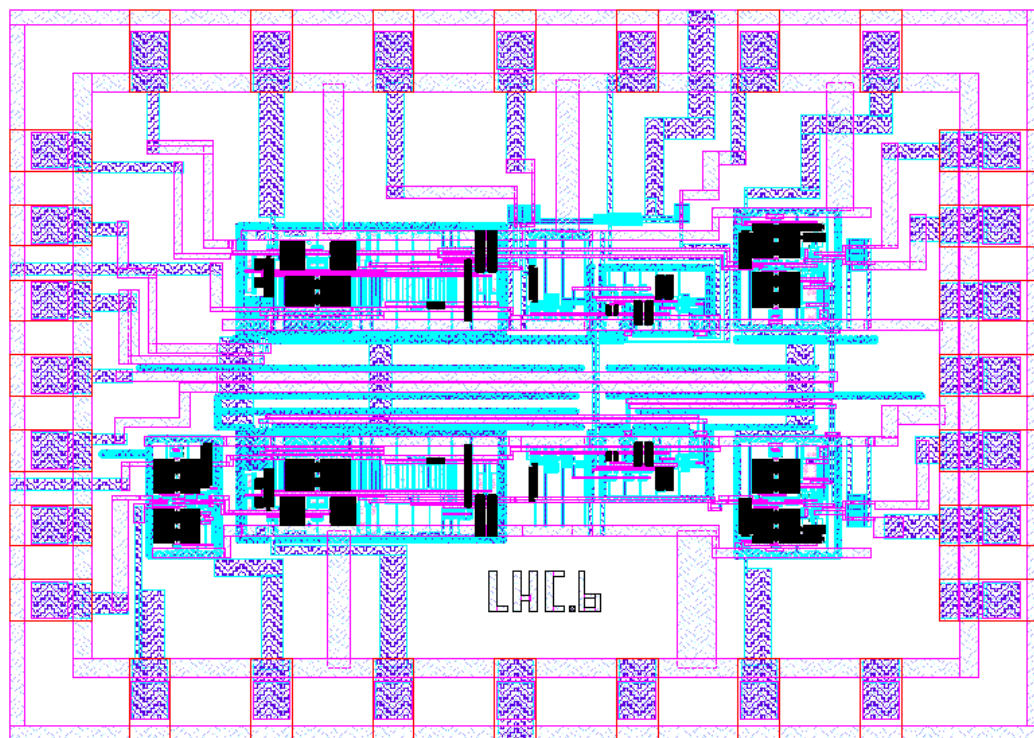

Figure 12: january layout