



Cross-sectional: ELECTRICAL ENGINEERING AND POWER ELECTRONICS

**ELECTROMAGNETIC INTERFERENCES IN TRANSISTOR
CONVERTERS AND METHODS OF INTERFERENCES MITIGATION**

V.K. Gurin¹, V.O. Pavlovskiy¹, O.M. Yurchenko¹, V.I. Senko²

¹*Institute of Electrodynamics of National Academy of Science of Ukraine, Prosp. Peremogy, 56, Kyiv, 03057, Ukraine.*

E-mail: yuon@ied.org.ua

²*Technical University of Ukraine "Igor Sikorsky Kyiv Polytechnic Institute", Prosp. Peremohy, 37 Kyiv, 03056, Ukraine. E-mail: ecampus@kpi.ua*

Abstract: This paper describes the main types of conductive electromagnetic interference that occur in modern high-frequency transistor converters and shows methods for these interferences' mitigation.

A network interference-suppression device which makes it impossible penetration of conductive electromagnetic interference (EMI) from a consumer to a mains and back is introduced. The device also provides the complete galvanic decoupling between the power mains and the consumer. This is achieved through the introduction of an intermediate link between the consumer and the network, the link being powered by a rechargeable battery, and time separation of electrical energy between consumption and transmission cycles due to the special algorithm of charging and discharging the batteries of the consumer. It provides mutual protection of the consumer and the network from all types of conductive EMI, as well as protection of the consumer from possible electric shock.

Keywords: *galvanic decoupling, conductive electromagnetic interference, rechargeable battery.*

1. Introduction

Any electrical device that is connected to the mains is known to generate electromagnetic interference (EMI) in the mains and in the environment [1]. Among such devices, the most common EMI generators are high-frequency transistor converters [2 - 6]. EMI levels generated by such converters may exceed the maximum allowable levels regulated by world standards for electromagnetic compatibility [7, 8]. This may cause to fail the converter itself or other devices connected to the mains.

The power network itself can act as a source of conductive EMI [9], such as differential mode (DM), common mode (CM), or power line disturbances, electrical fast transients that occur due to breaks or short circuits in power lines, lightning surges, human factor, etc. Such cases of power failures can cause great material damage, lead to breakdowns in the insulation of power wires and even to electric shocks.

2. Traditional tools and methods of EMI mitigation in modern transistor converters

The main ways and means of reducing conductive noise and EMI radiation in modern **transistor** converters (TC) include circuitry and design methods of these TC. Circuitry methods include circuit solutions that provide minimum levels of its conductive noise and EMI radiation. Schemes with the so-called "hard" or "soft" switching of TC power switches are a prime example.

In the first of these methods, the switching of the switch is carried out at a full voltage applied to the switch, or during the flow of maximum power current through the switch. In the second method, switching of the switch is performed in a period of time when the voltage on the switch or the current flowing through the switch is close to zero.

Design methods of reducing conductive noise and EMI radiation include rational installation of the TC circuit from the electromagnetic capability (EMC) point of view, correct organization of the path by which the power current is returned to the power supply, proper grounding of functional units and the TC itself.

For example, an effective design means of reducing conductive noise is the correct voltage supply to the power switch from the EMC) point of view, or, in other words, minimizing the inductance of the wires that supply voltage to the switch.

The fact is that, as it was mentioned above, the voltage U_L which occurs at the ends of the conductor when switching current, is equal to:

$$U_L = L \cdot \frac{di}{dt}. \quad (1)$$

At a given change rate of current (it is determined by the switch's speed and the nature of the load), U_L is proportional to the inductance of the conductor.

It is known that the inductance of a conductor is directly proportional to its length and depends on the shape of the conductor: the maximum inductance have round conductors, the minimum inductance - flat conductors when the width of the conductor significantly exceeds its thickness.



From these properties follows another method of reducing conductive interference – under designing the TC it is necessary to place the switches as close as possible to the input voltage terminals, and connect the switches to the voltage source by not round wires, but wide and flat busbars.

For modern types of field-effect transistors and IGBT, this method of applying voltage to the power switches of the TC is the most suitable.

Along with the above methods of reducing interference from TC, power line filters (they are also being called “noise filters” and “EMI filters”) have been widely used. The properties of these filters and their disadvantages are discussed in more detail below.

In practice, in order to increase electrical safety and attenuation introduced into the CM interference at low frequencies, a power transformer which provides galvanic isolation between the primary and secondary windings is being used between the mains and the consumer. The transformer with galvanic isolation between primary and secondary electrical circuits is also being used in modern transistor voltage converters. This technical solution increases the attenuation of CM noise at low frequencies, but is not a radical solution to the problem of isolation between the grid and the consumer at high frequencies due to the parasitic capacitance between primary and secondary windings of the transformer.

3. EMI filters and their disadvantages

To reduce the levels of conductive EMI generated by devices connected to the mains, EMI filters are widely used. Such filters have to meet to a number of specific and often contradictory requirements. The filter operates at a voltage of 220/380 V, the operating current up to hundreds of A, which is being consumed by the TC from the network, flows through the filter, and the voltage drop of industrial frequency (50 or 400 Hz) at the filter terminals should not exceed several volts. At the same time, such a filter must make a large and sufficiently uniform attenuation at frequencies where the noise of the TC can disrupt the normal operation of radio receivers, control and management circuits - from tens of kHz up to tens of MHz and above.

The capacitance of EMI capacitors which are included in the "phase-to-grounded case" circuit, is also subject to mutually opposite requirements. On the one hand, the larger the capacitance, the more attenuation the EMI filter inserts in the noise from the TC at the low-frequency end of the frequency range, which is to be protected. However, this increases EMI filter's leakage current, i.e. the current that can flow in the circuit "ungrounded filter case - ground". This current is a danger to a human when the ungrounded filter case and grounded equipment are touched by a human at the same time. Therefore, the total capacitance of the EMI filter in a circle "phase-to case" is usually limited to 0.02 - 0.05 μ F. It should be noted that the leakage current of the filter reduces the electrical safety of the device that is powered through the filter. It is caused by the fact, that according to an electrical safety standard, the maximum allowable current that can pass through the human body in normal (non-emergency) mode of operation of the electrical installation should not exceed 0.3 mA - for alternating current and 1 mA - for direct current [10].

The use of EMI filters may not always be acceptable in situations where it is necessary to ensure the minimum weight and size, or ultra-low levels of EMI [11-12].

Studies have shown that the attenuation introduced by the EMI filter is limited primarily by its own and mutual parasitic parameters [13], which, in turn, does not provide complete protection against conductive EMI.

The first of the mentioned parameters mainly includes parasitic inductances of filter capacitor's terminals and the parasitic winding capacitance of its inductor (Fig. 1).

Mutual parasitic parameters include inductive and capacitive parasitic coupling between different elements of the same filter, which reduce the attenuation of the filter for noise voltage (Fig. 2).

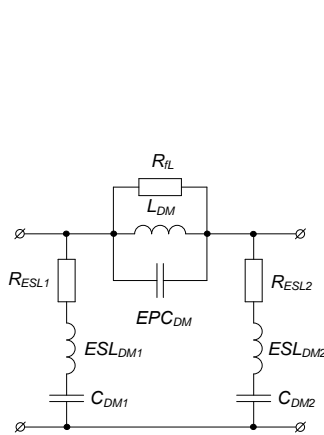

Fig. 1 Own parasitic parameters of EMI filter

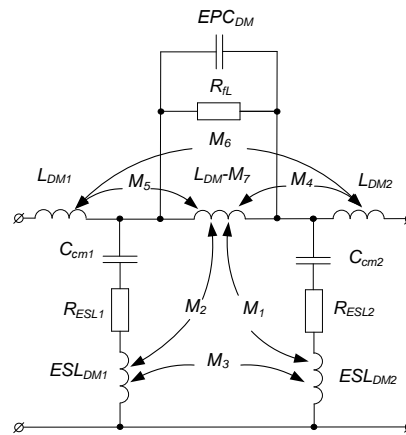

Fig. 2 Mutual parasitic parameters of EMI filter

In fig. 1 and 2: EPC_{DM} - parasitic winding capacitance of the choke; L_{DM} - choke's inductance; $L_{DM1,2}$ - parasitic inductances of input and output conductors of the filter; R_{IL} - equivalent resistance of the choke at its resonant



frequency; R_{ESL} - equivalent resistance of the capacitor at its resonant frequency; ESL_{DM} - parasitic inductance of capacitor's terminals; M_1, M_2 - inductive couplings between parasitic inductances of capacitors terminals and choke's inductance; M_3 - inductive coupling between parasitic inductances of capacitors terminals; M_4 - inductive coupling between parasitic inductances of output conductor of the filter and choke's inductance; M_5 - inductive coupling between parasitic inductances of input conductor of the filter and choke's inductance; M_6 - inductive coupling between parasitic inductances of input and output conductors of the filter; M_7 - inductive coupling between ground plane and filter's choke.

In fig.3 it is showed curves of the transfer factor (in dB) of the filter for CM noise in the frequency range of 100 kHz... 30 MHz [14].

Line 1 shows the transfer factor of the filter with ideal capacitors and an inductor; line 2 - the result of modeling taking into account its own parasitic parameters in the inductor of the noise filter; line 3 - the result of measurements of the transfer factor of the real filter for CM noise.

Fig. 4 shows graphs of the filter transfer factor for DM noise.

In these graphs, line 1 shows the transfer factor of the filter with ideal capacitors and an inductor; line 2 - the result of modeling, taking into account its own parasitic parameters; line 3 - the results of measurements of the transfer coefficient of the filter for DM noise.

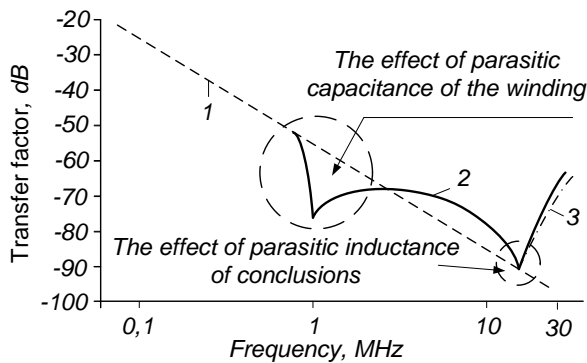

Fig. 3. Transmission ratio graphs
CM noises

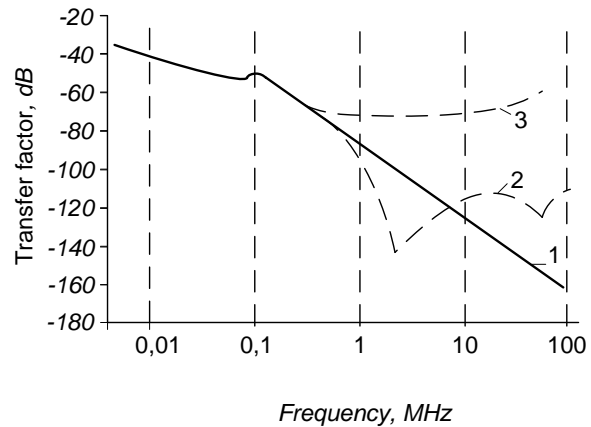

Fig. 4. Graphs of the filter transfer factor for DM noises

In practice, there were situations when the EMI filter itself turned into a source of EMI [15]; such a transformation created additional problems in the design of the filter and its functioning.

Ensuring the permissible level of EMI with the aid of RFI filters is being complicated by the fact that in the absence of RFI filters' grounding the filter can cause the tripping of differential relays [16], and in the relays absence - can cause electric shock or even death.

4. The role of parasitic parameters of transistor converters in generation and propagation of conductive EMI

Fig. 5 schematically shows a power transistor with a collector or drain isolated from the radiator housing (by means of a thermally conductive electrical insulating gasket); this design is found in almost every transistor converter.

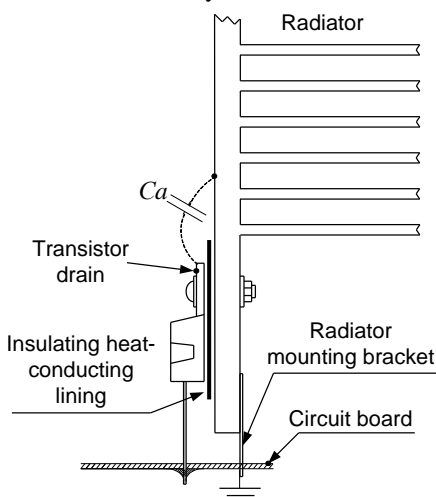

Fig. 5 Power transistor with
grounded radiator

This technical solution provides cooling of the power transistor, but at the same time it forms a parasitic capacitance between the collector or drain of the transistor and ground. A design option is also possible (in high-frequency converters of low and medium power), when the power transistor is installed on a radiator that has no electrical connection with the housing.

The parasitic capacitance C_a consists of two parts. The first part is the parasitic capacitance between the transistor drain and ground, and the second part is the capacitance between the PCB tracks and ground. C_b - includes: parasitic capacitance between the cathode of the diode D_b and ground, as well as parasitic capacitance between consumer and ground. C_c - includes the parasitic capacitance between the printed circuit board and the "ground", the parasitic capacitance between load and the grounded housing. Parasitic capacitance C_a , is one of the main reasons for the formation of a path for CM EMI current.

EMIs can penetrate into switch mode power supply (SMPS) through parasitic capacitances that are formed between the power



contacts of the SMPS and its grounded housing. A simplified diagram of one of these converters is shown in fig.6.

Conductive EMI is divided into two separate subtypes: DM EMI, which acts between the supply and return lines, and CM EMI, which acts between each supply's power line and ground.

The paths of DM EMI and CM EMI at the input of the power supply in a simplified form are shown in fig.7 which also shows the connecting of the LISN network with a spectrum analyzer as an EMI meter, and SMPS.

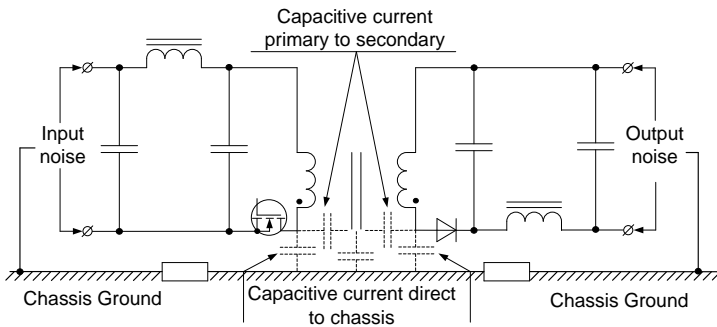

Fig. 6 (CM) the interference is caused by transients through the parasitic capacitor

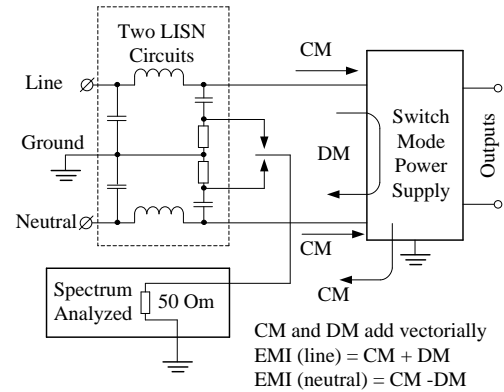

Fig. 7 (CM) and (DM) currents at the input of the power supply system

Modern transistor converters often use galvanic isolation from the network, but this solution does not provide protection against the mutual influence of EMI between the network and the consumer due to the structural interwinding capacitance in the transformer (fig. 6), which plays a major role in transmission high-frequency EMI from the consumer into the mains and vice versa.

Therefore, in practice, a special shielding winding is used to protect the EMI through the parasitic interwinding capacitance of the power transformer (fig. 6), but even such a technical solution does not provide full protection against mutual penetration of the EMI between the network and the consumer.

EMI filters also cannot provide galvanic isolation between the mains and the consumer, because functionally they are a low-pass filter in which the choke winding is connected between the mains and the consumer (fig. 1). In addition, due to parasitic parameters in the EMI filters elements they also cannot provide a complete EMI mitigation at high frequencies.

To radically solve this problem, more sophisticated methods are needed that allow almost complete elimination of EMI while providing a galvanic isolation between the grid and the consumer. One of this methods is described below.

5. An innovative method of providing a complete decoupling between the power mains and the consumer

The proposed technical solution was based on developing an anti-interference device with relay galvanic isolation from the mains, which eliminates direct electrical contact of the network with the consumer, which, in turn, will provide a high level of protection against all types of conductive EMI. The concept of relay galvanic isolation means the absence of conductive connection of the network with the consumer, which is provided by the rupture of the relay contact. This technical solution will protect the consumer from overvoltage and accidents in the grid that may be caused by natural or human factors.

Under the functioning of the device, the consumer which is connected to the mains must continuously receive electricity from the mains and at the same time be protected from the conductive EMI of all types that can be generated by this mains.

This functionality can be achieved due to the lack of conductive connection between the mains and the consumer, and this makes it possible to achieve a high level of protection against EMI and ensure a high level of electrical safety.

The problem is solved by the fact that to ensure a high and continuous level of protection against conductive EMI in the anti-interference device, a complete galvanic isolation is used fig.8.

The complete galvanic isolation is achieved with the aid of controlled switches, which interrupt the path for conductive EMI by the algorithm of the control circuit. To ensure the smooth operation of the consumer, electrical energy storage devices - rechargeable batteries are used.

Description of the anti-interference device components and principle of their operation.

The functional scheme of the proposed anti-interference device fig.8 includes: two-channel charger based on AC/DC converter, which is powered by a standard power supply $V_1 - 220V 50Hz$; switches $K_1 - K_8$, which are controlled by the control circuit, which generates control pulses to switch these switches according to the programmed algorithm.

Switch pairs (K_1K_2 ; K_3K_4 ; K_5K_6 ; K_7K_8) are switched synchronously.



The central part of fig. 8 shows the connection of two batteries (battery 1 and battery 2) which are connected to the AC/DC converter - charger, and to the DC/DC converter through the controlled switching switches K_1-K_8 . Battery 1 and battery 2 allow to provide autonomous transfer of energy to the consumer.

The switch management scheme controls the charge-discharge cycles of the battery1 and battery2 in such a way as to provide galvanic isolation of the grid from the consumer at any time and at the same time maintains a stable transmission of energy from the grid to the consumer.

DC/ DC converter includes an external regulator R_1 which adjusts the output voltage level required by the consumer.

An output voltage stabilizer is connected to the DC/DC converter, the function of which is to set the output voltage level V_2 . Diodes D_1 and D_2 protect against the interaction of battery 1 on battery 2 when they are connected in parallel to the consumer.

From the diagram shown in fig. 8 it can be seen that the anti-interference device is structurally similar to UPS (uninterruptible power supply). The main difference is that the control algorithm of switches provides the complete galvanic isolation between the network and the consumer due to physical ruption of the conductive path between them which is formed by opening the switches in a proper moment of time.

The operation of the anti-interference device fig.8 is to alternately reconnect the batteries between the mains and the consumer according to the algorithm issued by the control circuit (the switch management scheme). This control algorithm allows the charge and discharge cycles of the batteries to be separated in time [17], so that when charging one battery from the mains, the other battery is completely galvanically isolated from the first one, supplying accumulated energy to the consumer.

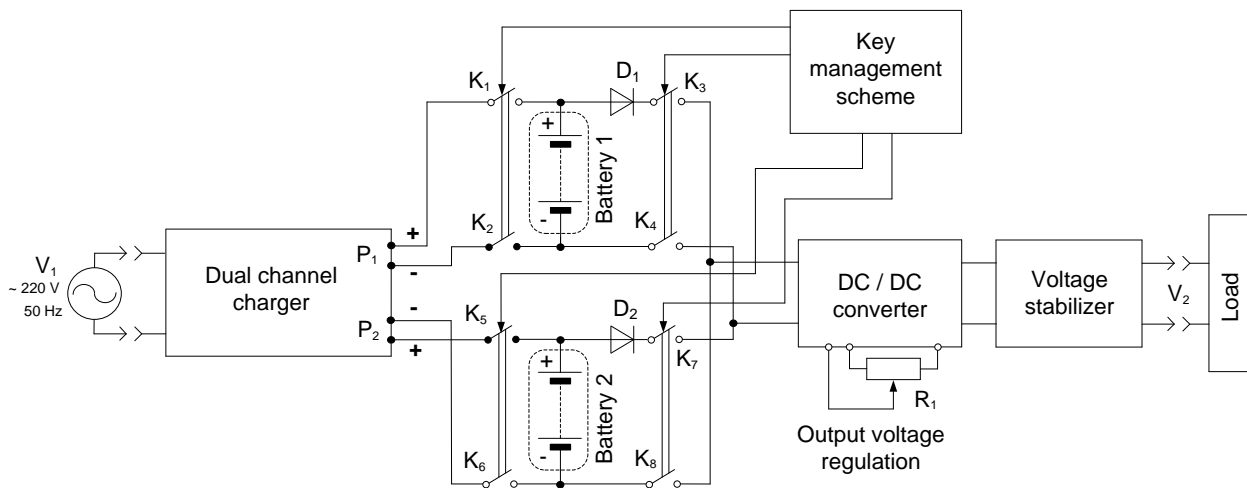

Fig.8 Anti-interference device with complete galvanic isolation

Rechargeable batteries (battery1, battery2) fig.8 are charged independently of each other, and the process of charging is controlled by the switch management scheme. Battery1 and battery2 alternately are being switched between the charger and the consumer by controlled switches $K_1 - K_8$ to provide galvanic isolation between the mains and the consumer at any time, providing a stable and continuous supplying the consumer with electrical energy while charging the battery which needs recharging.

Fig. 9 shows the switching modes of the eight switches K_1-K_8 , which are controlled by the control circuit.

The duration of batteries' charge and discharge is recorded by charge-discharge sensors of battery 1 and 2, and transmitted to the switch control circuit. It depends on consumer's power and is being regulated by the algorithm of switches $K_1 - K_8$ switching. Charge-discharge of battery 1 and 2 occurs according to the algorithms presented below.

At the initial moment of time, when the anti-interference device is not connected to the mains, all switches $K_1 - K_8$ are in the open state, thus ensuring a minimum discharge of the battery 1 and 2 in the standby mode.

Fig. 9 (a) shows mode I at the first moment in time, when the anti-interference device is connected to the mains, the control circuit (switch management scheme) generates the control signal to close the switches $K_1; K_2; K_5; K_6$. In this mode, it is being provided the simultaneous charging of two parallel and independently connected batteries at least up to 95% of the full battery charge, the switches $K_3; K_4; K_7; K_8$ remaining open.

During the period of charging the battery 1 and 2 - (Battery charging mode) the consumer is disconnected from them and does not receive energy until one of the batteries is charged and ready to give out its energy.

There is an inter-commutation pause after the mode I. This is a short-term mode in which one of the batteries is disconnected from the charger before connecting the battery to the consumer. This mode provides the complete galvanic isolation of the consumer from the mains during the time of switching the battery between the consumer and the charger.



After the battery1 or 2 is charged to at least 95% of their capacity, the battery that has reached the 95% charge level faster is the first to be disconnected from the charger and connected to the consumer.

Figure 9 (b) shows mode II for the situation when the battery 1 is first charged. In this mode, the switches K_1 and K_2 are being opened, and after them the switches K_3 and K_4 are closed and the battery 1 begins to give the accumulated energy to the consumer.

The battery gives its energy until discharged to 5% of the battery capacity, then the batteries are reconnected (switches K_5 ; K_6 - open, and K_7 ; K_8 - close) and the consumer begins to receive energy from the battery 2. This mode allows continuous energy transfer to the consumer while providing the complete galvanic isolation from the mains at the time of switches switching.

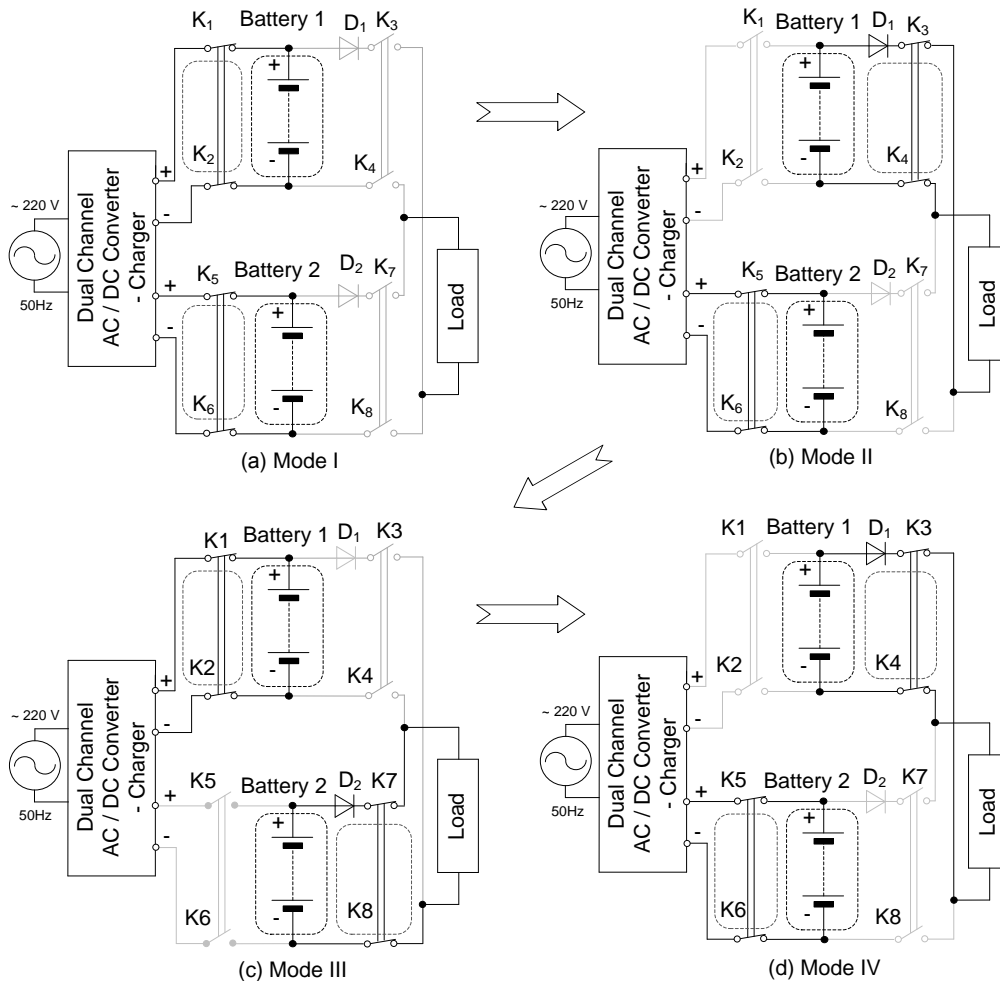

Fig.9 Description of algorithms for controlled switches.

Fig. 9 (c) describes mode III, during which the switches K_1 ; K_2 ; K_7 ; K_8 are closed, and switches K_3 ; K_4 ; K_5 ; K_6 - opened. In this mode, the battery1 is connected to the charger, and the battery2 gives the stored energy to the consumer until discharged to 5% of battery capacity.

After that another mode of inter- commutation pause begins, which is activated before connecting the battery 2 to the charger and the battery 1 to the consumer. In this mode the switches K_1 ; K_2 ; K_5 ; K_6 ; K_7 ; K_8 are open, and K_3 ; K_4 - closed. It allows to provide the complete galvanic isolation between the mains and the consumer at the time of switching the switches between the batteries.

The next mode IV (Fig. 9 (d)), in which the switches K_1 ; K_2 ; K_7 ; K_8 are opened and switches K_3 ; K_4 ; K_5 ; R_6 - closed. In this mode power is transferred again from the battery1 to the consumer, and the battery 2 is being charged from the AC/DC charger connected to the mains.

Thus, the full charge-discharge cycle of battery1 and battery 2 between the mains and the consumer is realized.

Conclusions

Due to use of the proposed anti-interference device, which provides the complete galvanic isolation between the mains and the consumer being connected to the mains, a new technical result is achieved compared to traditional methods of reducing conductive EMI – providing the complete protection against mutual penetration of all types of conductive interference between the main and the consumer, and ensuring a high level of electrical safety, which is



characterized by the absence of current leakage from the ungrounded housing of a device powered by the mains, to the ground.

References

1. Ott, H. W. (2009). *Electromagnetic Compatibility Engineering*. New Jersey: John Wiley & Sons, Inc.
2. Gurin, V.K. (2019). *Improving the effectiveness of noise reduction means in power supply systems with high-frequency transistor converters*. (Candidate's thesis). Institute of Electrodynamics of National Academy of Sciences of Ukraine. Kyiv: 150 p. (in Ukrainian) Available from: http://ied.org.ua/disertac/disert_Gurin.pdf
3. Xu, L., Wang, J., Illindala, M.S. (2013). *EMI Modeling and Characterization for Ultra-Fast Switching Power Circuit Based on SiC and GaN Devices*. (PhD thesis). Ohio State University. Available from: https://etd.ohiolink.edu/apexprod/rws_etd/send_file/send?accession=osu1385983252&disposition=inline
4. Lantsov, B., Eranosyan, C. (2006). Electromagnetic compatibility of switching power supplies: problems and solutions. Part I. *Power electronics*, 4-2006, 58-64. (in Russian). Available from: http://power-e.ru/pdf/2006_04_58.pdf
5. Zagorskiy, V. (2004). Electromagnetic compatibility of switching power supplies and its optimization. Part 1. *Components and technologies*. 2-2004, 30-35. (in Russian). doi:10.0000/cyberleninka.ru/article/n/elektromagnitnaya-sovmestimost-impulsnih-istochnikov-pitaniya-i-ee-optimizatsiya-chast-1
6. Beloturov, V. (2005). Filtration and overvoltage protection modules from Vicor. *Power Electronics*. 2-2005, 104-107. (in Russian). Available from: http://powel.ru/files/library/VicorAC_DC.pdf
7. EN 55022:2014. Information technology equipment - Radio disturbance characteristics - Limits and methods of measurement.
8. IEC 61000-2-4-2002. Electromagnetic compatibility (EMC) - Part 2-4: Environment - Compatibility levels in industrial plants for low-frequency conducted disturbances.
9. Lundmark, M. (2006) *High-Frequency Noise in Power Grids, Neutral and Protective Earth*. Luleå University of Technology.
10. DSTU GOST 12.1.038:2008 "Occupational safety standards system. Electrical safety. Maximum permissible values of pickup voltages and currents".
11. Gurevich, V. (2005). Electromagnetic Terrorism: New Hazards. *Electrical Engineering and Electromechanics*. 4. 81-83.
12. Napp, A., Joosten, S., Stunder, D., Knackstedt, C., Zink, M., Bellmann, B., ... Silny J. (2014) Electromagnetic interference with implantable cardioverter-defibrillators at power frequency. *Circulation*, 129, 441-450. doi: 10.1161/CIRCULATIONAHA.113.003081
13. Wang, S., Chen, R., Van Wyk, J.D. (2005). Developing Parasitic Cancellation Technologies to Improve EMI Filter Performance for Switching Mode Power Supplies. *IEEE Transactions on Electromagnetic Compatibility*, 47(4), 921-929.
14. Gurin V.K.; Pavlovskiy V.O.; Yurchenko O.M. (2012). Self-parasitic and mutual parasitic parameters in power line filters for switching mode power supplies. *Tekhnichna Elektrodynamika*. 2012(2), 119-120. (in Ukrainian) Available from: <http://dspace.nbu.gov.ua/bitstream/handle/123456789/62135/57-Gurvin.pdf?sequence=1>
15. Pavlovskiy V.A. (1990) Power line filter as a source of noise. *Tekhnichna Elektrodynamika*, 1990(5), 65-70. (in Russian) Available from: http://previous.techned.org.ua/index.php?option=com_content&view=article&id=907&Itemid=77
16. Li, C., Liang, J., Wang, S. (2018). Interlink Hybrid DC Circuit Breaker. *IEEE Transactions on industrial electronics*, 65(11), 8677-8686. Available from: <https://ieeexplore.ieee.org/stamp/stamp.jsp?arnumber=8304668>
17. Basin, E.N. (1988). Network rectifier for secondary power supplies with increased conversion frequency. *Radiotekhnika*, 1988(4). 29-31. (in Russian)