



Publication Year	2018
Acceptance in OA @INAF	2020-11-11T11:15:44Z
Title	Design of Cryogenic Phased Array Feed for 4-8 GHz
Authors	NAVARRINI, Alessandro; MONARI, JADER; SCALAMBRA, ALESSANDRO; MELIS, Andrea; CONCU, Raimondo; et al.
Handle	http://hdl.handle.net/20.500.12386/28254

DESIGN OF CRYOGENIC PHASED ARRAY FEED FOR 4-8 GHz

A. Navarrini⁽¹⁾, J. Monari⁽²⁾, A. Scalambra⁽²⁾, A. Melis⁽¹⁾, R. Concu⁽¹⁾, G. Naldi⁽²⁾, A. Maccaferri⁽²⁾, A. Cattani⁽²⁾, P. Ortu⁽¹⁾, J. Roda⁽²⁾, F. Perini⁽²⁾, G. Comoretto⁽³⁾, M. Morsiani⁽²⁾, A. Ladu⁽¹⁾, S. Rusticelli⁽²⁾, A. Mattana⁽²⁾, P. Marongiu⁽¹⁾, A. Saba⁽¹⁾, M. Schiaffino⁽²⁾, E. Carretti⁽²⁾, F. Schillirò⁽⁴⁾, E. Urru⁽¹⁾, G. Pupillo⁽²⁾, M. Poloni⁽²⁾, T. Pisanu⁽¹⁾, R. Nesti⁽³⁾, G. Muntoni⁽¹⁾, K. Zarb Adami^(5,6), A. Magro⁽⁵⁾, R. Chiello⁽⁶⁾, L. Liu⁽⁶⁾, K. Grainge⁽⁷⁾, M. Keith⁽⁷⁾, M. Pantaleev⁽⁸⁾, W. van Cappellen⁽⁹⁾

⁽¹⁾ INAF-Osservatorio Astronomico di Cagliari, via della Scienza 5, Selargius, Italy, alessandro.navarrini@inaf.it

⁽²⁾ INAF-Istituto di Radioastronomia, Bologna, Italy

⁽³⁾ INAF-Osservatorio Astrofisico di Arcetri, Florence, Italy

⁽⁴⁾ INAF-Osservatorio Astrofisico di Catania, Catania, Italy

⁽⁵⁾ University of Malta, Malta

⁽⁶⁾ University of Oxford, Department of Physics, UK

⁽⁷⁾ University of Manchester, Jodrell Bank Observatory, UK

⁽⁸⁾ Onsala Space Observatory, Chalmers, Sweden

⁽⁹⁾ ASTRON, Dwingeloo, The Netherlands

Abstract

We describe the design and architecture of PHAROS2, a cryogenically cooled 4-8 GHz Phased Array Feed (PAF) demonstrator with digital beamformer for radio astronomy application. The instrument will be capable of synthesizing four independent single-polarization beams by combining 24 active elements of an array of Vivaldi antennas.

PHAROS2, the upgrade of PHAROS (PHased Arrays for Reflector Observing Systems), features: a) commercial cryogenic LNAs with state-of-the-art performance, b) a “Warm Section” for signal filtering, conditioning and single downconversion to select a ≈ 275 MHz Intermediate Frequency (IF) bandwidth within the 4-8 GHz Radio Frequency (RF) band, c) an IF signal transportation by analog WDM (Wavelength Division Multiplexing) fiber-optic link, and d) a FPGA-based Italian Tile Processing Module (iTPM) digital backend.

Index Terms – Antennas, digital backend, down-conversion, Phased Array Feed (PAF).

I. PHASED ARRAY FEEDS

Phased Array Feeds (PAFs) are a key technology enabling the next major advancement in radio astronomy. In contrast to multi feeds, the elements of a PAF are densely packed ($\approx 0.5 \lambda$ at the highest design frequency) and combined in weighted sums to form multiple independent beams. The beams and the antenna properties resulting from a PAF equipped with a digital beamformer can be optimized, using frequency-dependent weights, for each of the backend frequency channels (of order ≈ 1 MHz) leading to high antenna aperture efficiencies and low spillover losses for

all the synthesized beams over the entire band. The flexibility of a PAF allows achieving a complete coverage of the available radio telescope Field of View (FoV,) thus increasing the survey speed if compared to a single-pixel feed.

II. PHAROS PHASED ARRAY FEED

PHAROS is a C-band cryogenically cooled low noise PAF with analogue beamformer designed to operate at the focus of a large single-dish radio telescope. Figures 1 and 2 show respectively, a schematic system diagram of PHAROS and a more detailed block diagram of the front-end. Views of the PHAROS PAF and of the dome-shaped vacuum window with array of antennas are shown in Fig. 3. A description of the instrument can be found in [1, 2]. PHAROS consists of a 220-element Vivaldi array cooled at ≈ 20 K along with 24 low noise amplifiers (LNAs) mounted behind the antenna elements. The LNAs are cascaded with low-loss low-thermal conduction RF connections to the analogue beam former designed to operate at ≈ 77 K. The RF signals of the active elements are distributed to the beam formers by passive splitters, while the non-active elements are terminated into 50Ω loads. Four beam former modules are available inside the cryostat, each with 13 RF inputs and 13 individually controllable phase and amplitude control units (PACs), along with 13

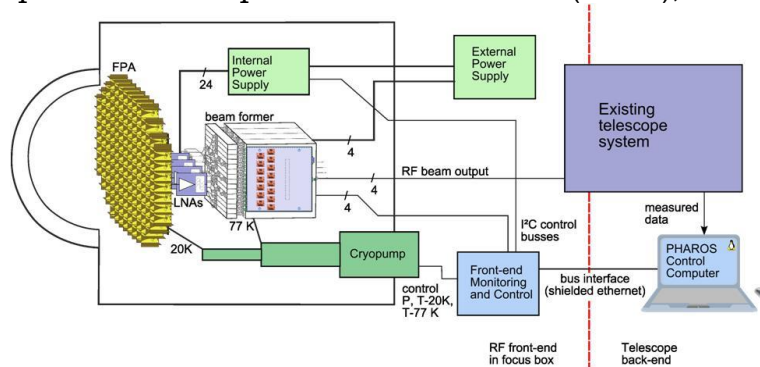

FIG. 1 – PHAROS system diagram.

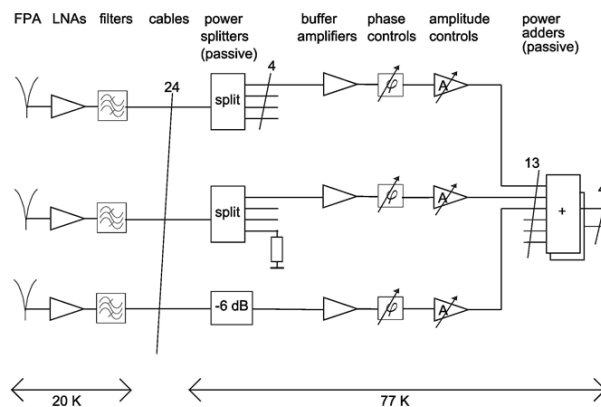

FIG. 2 – PHAROS system diagram showing the analog beamformer components (including buffer amplifier, phase controls, amplitude controls and passive power adders).

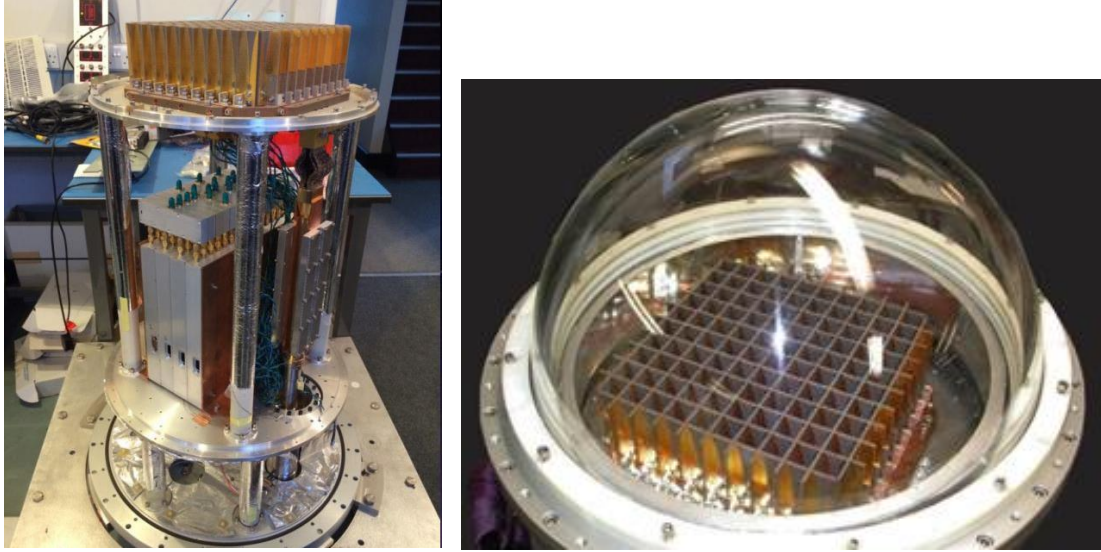

FIG. 3 – View of PHAROS instrument: left) during assembly, right) showing half-dome vacuum window and array of Vivaldi antennas.

amplifiers to compensate for system losses. The last stage of the analogue beam forming system is a 16-way Wilkinson combiner (with three unused inputs). Each analog beam former controls the weights of the amplitude and of the phase from 13 antenna elements to produce a single (compound) one-polarization beam.

III. PHAROS2

PHAROS is being upgraded to PHAROS2, a new PAF with digital beamformer. The latter re-uses part of the existing PHAROS hardware, including the cryostat and the array of Vivaldi antennas. PHAROS2 is under development in the framework of the SKA (Square Kilometer Array) PAF Advanced Instrumentation Program as a collaboration among the following institutions: the National Institute for Astrophysics (INAF, Italy), the Jodrell Bank Observatory (University of Manchester, UK), the Netherland Institute for Radio Astronomy (ASTRON, the Netherland), the Onsala Space Observatory (OSO, Sweden) and the University of Malta (Malta). In PHAROS2 a digital beamformer (at room temperature) replaces the four PHAROS analog beamformers.

The main PHAROS2 capability will be the possibility of digitally forming four independent beams on the sky using 24 antenna elements, each beam covering an instantaneous IF bandwidth of ≈ 275 MHz across 375-650 MHz [3]. We aim at completing and installing PHAROS2 on a large European single-dish radio telescope and carry out the technical validation of the instrument, including antenna efficiency optimization and multi-beaming scientific observations for demonstration of the adopted technologies that may find application in the SKA.

The architecture of PHAROS2 (see schematic layout in Fig. 3) consists of three main blocks: a) the “PHAROS2 cryostat,” to be equipped with new LNAs and possibly a new vacuum window; b) the “Warm Section,” to be

located in the primary focus receiver room, next to the cryostat; c) the “iTPM digital backend,” to be located in the backend room.

The Warm Section (WS) is connected to the digital backend through analog WDM fiber optic links allowing to transport two IF signals over a single fiber.

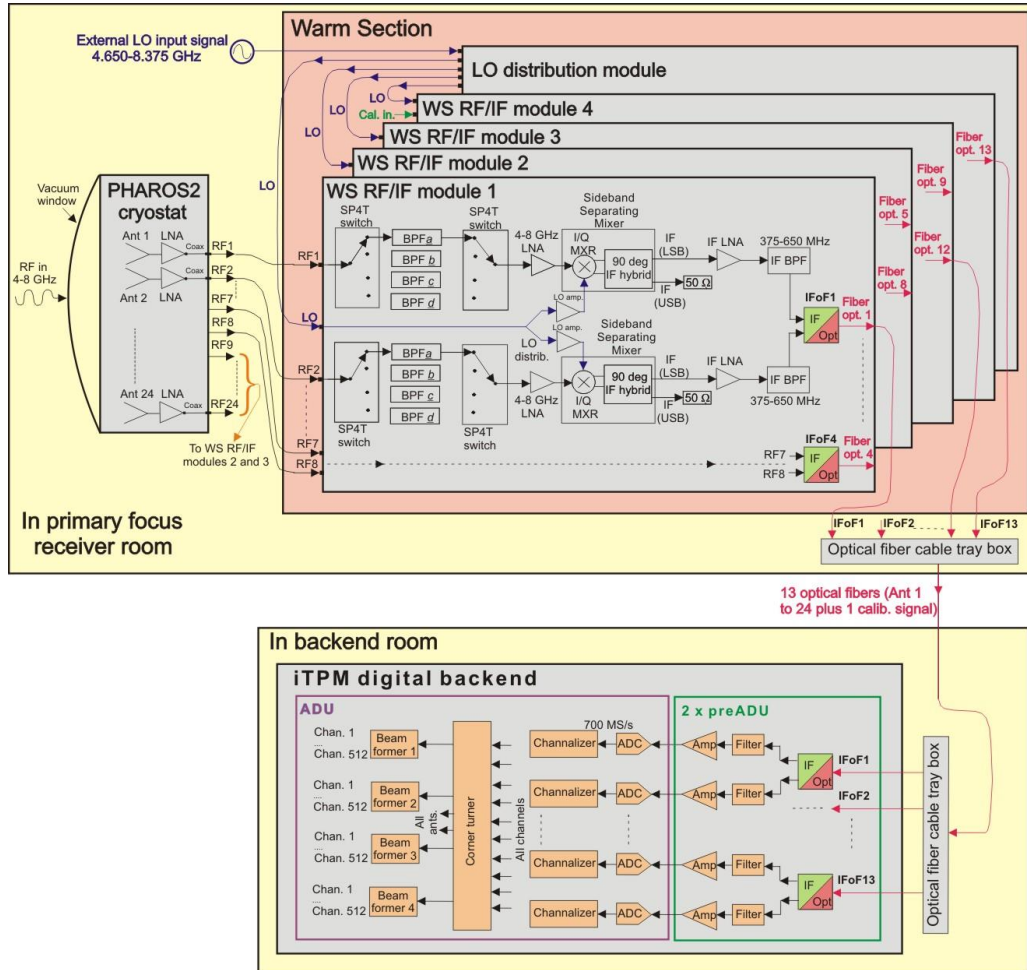

FIG. 4 – Schematic diagram of PHAROS2.

REFERENCES

- [1] J. Simons, J.G. Bij de Vaate, M.V. Ivashina, M. Zulliani, V. Natale, N. Roddis, “Design of a Focal Plane Array system at cryogenic temperatures,” Antennas and Propagation, EuCAP 2006, Nice, France, Nov. 2006.
- [2] L. Liu, K. Grainge, A. Navarrini, “Analysis of Vivaldi array antenna for phased array feeds application,” International Conference on NEMO, IEEE MTT-S, Sevilla, Spain, 17-19 May, 2017, doi 10.1109/NEMO.2017.7964244.
- [3] G. Naldi, G. Comoretto, R. Chiello, S. Pastore, A. Mattana, A. Melis, R. Concu, M. Alderighi, J. Monari, A. Navarrini, F. Schillirò, K. Zarb Adami, “Development of a digital signal processing platform for the Square Kilometre Array,” To be published in Proceedings of URSI-AT RASC Conference, Gran Canaria, Spain, May 28th-June 1st, 2018.