

This is a repository copy of *Luxury Hotel Booking and Scarcity Messages : Does Online Purchase Behavior Matter?*.

White Rose Research Online URL for this paper:
<https://eprints.whiterose.ac.uk/182945/>

Version: Accepted Version

Proceedings Paper:

Banerjee, Snehasish orcid.org/0000-0001-6355-0470 and Pal, Anjan (2020) *Luxury Hotel Booking and Scarcity Messages : Does Online Purchase Behavior Matter?* In: *2020 6th International Conference on Information Management (ICIM)*. International Conference on Information Management, 27-29 Mar 2020 , GBR , pp. 101-105.

<https://doi.org/10.1109/ICIM49319.2020.244678>

Reuse

Items deposited in White Rose Research Online are protected by copyright, with all rights reserved unless indicated otherwise. They may be downloaded and/or printed for private study, or other acts as permitted by national copyright laws. The publisher or other rights holders may allow further reproduction and re-use of the full text version. This is indicated by the licence information on the White Rose Research Online record for the item.

Takedown

If you consider content in White Rose Research Online to be in breach of UK law, please notify us by emailing eprints@whiterose.ac.uk including the URL of the record and the reason for the withdrawal request.

Luxury Hotel Booking and Scarcity Messages: Does Online Purchase Behavior Matter?

Snehasish Banerjee

The York Management School

University of York

York, UK

e-mail: snehasish.banerjee@york.ac.uk

Anjan Pal

School of Communication and Information

Nanyang Technological University

Singapore

e-mail: anjan001@ntu.edu.sg

Abstract—Hotel booking websites commonly use scarcity messages to sell hotels’ vacant room inventory. However, the effects of these messages on consumers’ booking intention still remain unclear. Focusing specifically on luxury hotels, this paper seeks to address three research questions: (1) How do limited-quantity scarcity messages (e.g., “20% discount – Only 1 room left”) differ from limited-time scarcity messages (e.g., “20% discount – Only 1 day left”) in affecting consumers’ luxury hotel booking intention? (2) How do frequent online purchasers differ from occasional online purchasers in their luxury hotel booking intention in response to scarcity messages? (3) Is there an interaction effect between scarcity message format (limited-quantity vs. limited-time) and online purchase frequency (frequent vs. occasional) on consumers’ luxury hotel booking intention? Data came from 96 participants who took part in an online experiment. Results indicate that limited-time scarcity messages induced higher booking intention compared with limited-quantity scarcity messages. Moreover, frequent online purchasers exhibited higher booking intention compared with occasional purchasers. However, the interaction was non-significant. The findings have implications for luxury hotel managers, hotel booking websites, and online consumers. While frequent purchasers getting influenced by scarcity messages is a good sign for marketers, the paper serves to remind the consumers not to become shopaholic in terms of their online buying behavior.

Keywords—*e-tourism, hotel booking, luxury consumption, luxury hotel, online shopping, scarcity message*

I. INTRODUCTION

A. Background

With the proliferation of tourism, demands of hotels continue to rise. In particular, the luxury hotel industry has now firmly established itself as one of the major service industries [1]. Its market globally was approximately USD 154 billion in 2015, and is expected to reach almost USD 195 billion by 2021 [2]. In fact, the global luxury hotels market is expected to grow significantly at least until 2025 due to increasing purchase power of consumers, especially those who are young [3].

Of all the hotel segments, luxury hotels boast of the highest occupancy rate [4]. Nonetheless, these hotels still need to promote their services in order to continually pique consumers’ booking intention. After all, hotel rooms unsold

at a given date cannot be stored for future sale. A commonly used promotional strategy used by hotels—irrespective of whether or not they belong to the luxury segment—is scarcity messaging in the online environment [5].

For the purpose of this paper, scarcity messages refer to promotional notifications on online hotel booking websites that highlight a paucity, and hence trigger a sense of booking urgency among consumers. They work on the principle that the less available something is, the more consumers want it [6]. Scarcity messages positively influence the perceived value and desirability of a product or service [7-9]. Therefore, consumers exposed to scarcity messages tend to show higher booking intention, perhaps almost impulsively regardless of the product or the service at stake, compared with those who do not come across such messages.

Luxury hotels can implement scarcity messaging in at least two frequently used formats: limited-quantity or limited-time. With a limited-quantity scarcity message format (e.g., “only one room left at this price”), they could make a promotional offer available to consumers for a predefined number of rooms. In contrast, with a limited-time scarcity message format (e.g., “only one day left to secure this price”), luxury hotels could make the promotional offer available to consumers for a predefined duration [10].

B. Research Gaps

In this context, two research gaps can be identified. First, the impact of limited-quantity and limited-time scarcity messages on consumers’ luxury hotel booking intention is still unknown. Addressing this research gap is of practical relevance for luxury hotel managers. Compared with economy hotel consumers, those interested in luxury hotels tend to be less sensitive to price and monetary value but are more concerned about experiential and symbolic value [11]. An understanding of how the luxury hotel consumer base responds to promotional offers—in either limited-quantity or limited-time formats—is necessary for marketers in order to develop appropriate scarcity messaging strategies.

Second, the current scholarly understanding of how consumers’ individual differences affect their responses to scarcity messages is limited. To plug this research gap, the current paper specifically focuses on the individual difference of online purchase frequency. Apparently, frequent online purchasers could be persuaded easily by promotional offers. Nonetheless, they are also expected to be highly price-sensitive, and perhaps would leave no stones

returned in actively searching for lower prices [12]. How they would differ from occasional online purchasers in responding to scarcity messages for a luxury service makes for an interesting revelation.

C. Research Questions

Guided by the identified research gaps, this paper seeks to answer the following three research questions (RQs) as pictorially depicted in Fig. 1.

RQ 1: How do limited-quantity scarcity messages differ from limited-time scarcity messages in affecting consumers' luxury hotel booking intention?

RQ 2: How do frequent online purchasers differ from occasional online purchasers in their luxury hotel booking intention in response to scarcity messages?

RQ 3: Is there an interaction effect between scarcity message format (limited-quantity vs. limited-time) and online purchase frequency (frequent vs. occasional) on consumers' luxury hotel booking intention?

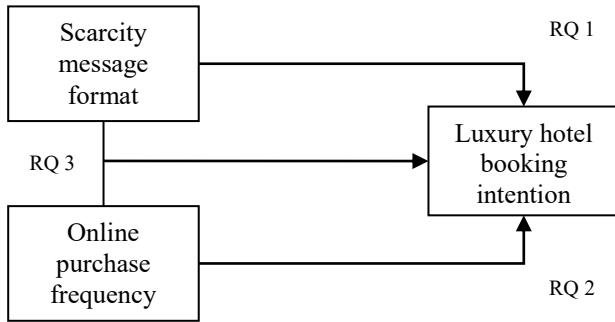

Figure 1. Pictorial representation of the research questions.

To address these three RQs, an online experiment was conducted, the details of which are provided in Section II. Section III thereafter presents the results of the data analysis. Finally, Section IV of the paper concludes with notes on its findings, implications, limitations and directions for future research.

II. METHODS

A. Research Design

A 2 (scarcity message format: limited-quantity vs. limited-time) \times 2 (online purchase frequency: frequent vs. occasional) between-participants factorial experimental design was implemented online. Such a research design has been followed in related works [5, 10]. Scarcity message format was manipulated in the experiment whereas participants' online purchase frequency was captured using a screening question.

Participants were told that they were taking part in market research, and the experimental stimuli were newly designed web-based promotional materials. This was necessary to heighten the contextual importance.

Participants were first asked to imagine that they were looking for a luxury accommodation for their two-night visit to Paris next month. Paris was chosen as the destination

because it is one of the best known and most visited cities of the world [13]. Next, the participants were exposed to the experimental stimuli (cf. Section II, Sub-section B). After exposure to the stimuli, they were required to fill out a questionnaire (cf. Section II, Sub-section C).

B. Experimental Stimuli

The online experiment manipulated scarcity message format. In the limited-quantity condition, the stimulus contained the annotation “20% discount – Only 1 room left” as show in Fig. 2. In the limited-time condition, the stimulus contained the annotation “20% discount – Only 1 day left” as shown in Fig. 3.

It should be noted that the distinction between a limited-quantity (“20% discount – Only 1 room left”) and a limited-time (“20% discount – Only 1 room left”) scarcity message is quite objective. Hence, a pre-test for manipulation check was not necessary [14].

To control for confounding factors, several aspects of the experimental stimuli were held constant. These include, for example, the website interface, the name and the logo of the hotel, the volume of reviews, the average review score, as well as the description of the hotel. A fictitious hotel name and logo was used to control for participants' attitudes and predispositions.



Figure 2. Limited-quantity scarcity message experimental stimulus.



Figure 3. Limited-time scarcity message experimental stimulus.

C. Participant Recruitment and Questionnaire

The invitation for study participation, which contained the URL to the experiment website, was disseminated using social media. The experiment website used a screening question that asked participants how often they had engaged in online shopping per month on average over the last year. The participants could choose one of the following three options: less than once a month, one to four times a month, more than four times a month.

Those who had engaged in online shopping more than four times a month on average were deemed as frequent purchasers. Those who had engaged in online shopping less than once a month on average were deemed as occasional purchasers [15]. However, those who had engaged in online shopping one to four times a month were deemed as moderate purchasers, who were not the focus of this paper.

Eventually, data came from 96 participants: 42 frequent online purchasers, and 54 occasional online purchasers. Of them, 59 were females while the rest were males. The most dominantly represented age group was 18-30 years.

These participants were randomly assigned to one of the two scarcity message format: limited-quantity vs. limited-time. Then, they answered a questionnaire that measured their booking intention for the luxury hotel shown in the experimental stimulus.

Specifically, luxury hotel booking intention was measured by asking the participants their likelihood (1 = very unlikely, 7 = very likely) that they would consider booking their stay at the luxury hotel, they would be happy to book their stay at the luxury hotel, and it would be a possibility for them to book their stay at the luxury hotel. Responses to the three items were averaged to create a composite index, with higher scores indicating greater luxury hotel booking intention (Cronbach's $\alpha > 0.7$).

III. DATA ANALYSIS AND RESULTS

The data were analyzed using a two-way factorial analysis of variance (ANOVA). The two independent variables included scarcity message format (limited-quantity vs. limited-time), and online purchase frequency (frequent vs. occasional). The dependent variable was luxury hotel booking intention.

Prior to the data analysis using ANOVA, homogeneity of variance was checked using Levene's test for equality of variances. The result was almost non-significant ($p = 0.045$). Moreover, the Normal Q-Q plot suggested a reasonable level of normality for luxury hotel booking intention [16].

Table I shows the descriptive statistics, from which two patterns emerge. One, luxury hotel booking intention was relatively higher for limited-time scarcity messages than that for limited-quantity scarcity messages. Two, luxury hotel booking intention was relatively higher among frequent online purchasers than that among occasional online purchasers.

According to the ANOVA results, the main effect of scarcity message format was statistically significant, $F(1, 92) = 9.73$, $p = 0.002$, $\eta_p^2 = 0.096$. Luxury hotel booking intention was significantly higher for limited-time scarcity

messages ($N = 53$, $M = 5.48$, $SD = 1.31$) vis-à-vis limited-quantity scarcity messages ($N = 43$, $M = 4.71$, $SD = 1.55$).

The main effect of online purchase behavior was also statistically significant, $F(1, 92) = 5.59$, $p = 0.02$, $\eta_p^2 = 0.057$. Luxury hotel booking intention was significantly higher among frequent online purchasers ($N = 42$, $M = 5.47$, $SD = 1.40$) vis-à-vis occasional online purchasers ($N = 54$, $M = 4.88$, $SD = 1.48$).

However, no statistically significant interaction effect was detected between scarcity message format and online purchase frequency, $F(1, 92) = 1.674$, $p = 0.199$, $\eta_p^2 = 0.018$.

TABLE I. DESCRIPTIVE STATISTICS

Scarcity Message	Purchase Behavior	Composite Index for Luxury Hotel Booking Intention			
		N	M (SD)	Mdn	Min, Max
LQ	Frequent	22	4.86 (1.51)	4.00	2.67, 7.00
LQ	Occasional	21	4.55 (1.60)	5.00	1.00, 7.00
LT	Frequent	20	6.13 (0.91)	6.00	3.67, 7.00
LT	Occasional	33	5.08 (1.37)	5.00	2.00, 7.00

Note. LQ = Limited-quantity scarcity message, LT = Limited-time scarcity message.

IV. DISCUSSION AND CONCLUSIONS

A. Research Findings

The findings of this paper corresponding to the three RQs are presented below, and pictorially depicted in Fig. 4.

RQ 1: How do limited-quantity scarcity messages differ from limited-time scarcity messages in affecting consumers' luxury hotel booking intention? Limited-time scarcity messages resulted in significantly higher luxury hotel booking intention compared with limited-quantity scarcity messages.

RQ 2: How do frequent online purchasers differ from occasional online purchasers in their luxury hotel booking intention in response to scarcity messages? Frequent online purchasers exhibited significantly higher luxury hotel booking intention compared with occasional online purchasers.

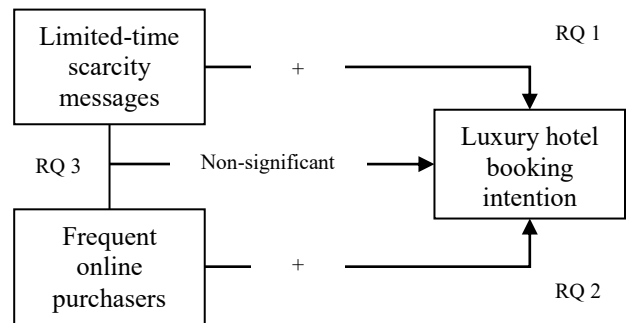

Figure 4. Pictorial representation of the findings for the research questions.

RQ 3: Is there an interaction effect between scarcity message format (limited-quantity vs. limited-time) and online purchase frequency (frequent vs. occasional) on consumers' luxury hotel booking intention? Scarcity message format (limited-quantity vs. limited-time) and online purchase frequency (frequent vs. occasional) did not interact with each other to affect consumers' luxury hotel booking intention. In other words, limited-time scarcity messages resulted in significantly higher luxury hotel booking intention regardless of online purchase frequency. Conversely, frequent online purchasers exhibited significantly higher luxury hotel booking intention regardless of scarcity message format.

B. Discussion of the Findings and Implications

Over the years, scholars have widely explored how limited-quantity and limited-time scarcity messages affect purchase intention in the offline context. But similar research in the online context is relatively scanty.

Recent works, such as [10], nevertheless showed that both limited-quantity and limited-time scarcity messages positively influence consumers' purchase decisions. Works such as [7] found that limited-quantity scarcity messages had a greater effect on the purchase decision for conspicuous products (e.g., mobile phone), but limited-time scarcity messages had a greater effect on the purchase decision for inconspicuous products (e.g., body wash).

Extending the current literature, this paper shows that limited-time scarcity messages work better than limited-quantity scarcity messages in inducing booking intention for luxury hotels. Hence, luxury hotel managers could consider liaising with hotel booking websites to use limited-time scarcity messages as a way to sell the vacant room inventory.

Furthermore, previous research on scarcity messages has studied individual differences such as need for uniqueness [9]. To the best of our knowledge, this is the first study to empirically examine the role played by purchase frequency. While frequent purchasers getting influenced by scarcity messages is a good sign for marketers who look to sweeten deals for consumers by hook or by crook, this paper serves to remind the consumers not to become shopaholic. They should proactively take steps to curb their online spending so as to prevent developing a compulsive buying disorder [17-20].

C. Limitations and Future Work

Three inherent limitations of the paper need to be acknowledged. First, the sample size in each cell of the experimental conditions was not too large. Interested scholars could look to replicate the current experiment with larger samples.

Second, the paper studied luxury hotel booking intention without granularly looking at different categories of luxury hotels such as business hotels, suite hotels, resorts and spas. Further research is needed to check if the current findings could be generalized to all categories of luxury hotels.

Third, the experimental stimuli shown to the participants held the polarity of reviews constant as indicated through the annotation "Review score: 4.5 out of 5 – Based on over 500 customer reviews" (cf. Fig. 2 and Fig. 3). However, it is

possible for luxury hotels to attract less positive reviews. An interesting research direction therefore lies in examining the effect of scarcity messages by varying the aggregated review polarity. Going forward, such a line of investigation could be extended to different products and services beyond luxury hotels.

ACKNOWLEDGMENT

The authors thank Maria Joana for preparing an initial version of the experimental stimuli.

REFERENCES

- [1] Reuters, "Global luxury hotel market analysis 2019 by size, share, trends, segmentation and vendors, industry overview, demand, customer behavior and forecast 2024," 5 February 2019, available at: <https://www.reuters.com/brandfeatures/venture-capital/article?id=80660>
- [2] Zion Market Research, "Worldwide trends in luxury hotels market share will grow usd 194.63 billion by 2021," 7 February 2019, available at: <https://www.globenewswire.com/news-release/2019/02/07/1712085/0/en/Worldwide-Trends-in-Luxury-Hotels-Market-Share-Will-Grow-USD-194-63-Billion-By-2021-Zion-Market-Research.html>
- [3] W. F. Chen, "The perceived cosmopolitan consumption of globally mobile, young consumers from China," *Young Consumers*, vol. 19, no. 4, Nov. 2018, pp. 450-464, doi:10.1108/YC-01-2018-00769.
- [4] S. Jang, and L. Moutinho, "Do price promotions drive consumer spending on luxury hotel services? The moderating roles of room price and user-generated content," *International Journal of Hospitality Management*, vol. 78, Apr. 2019, pp. 27-35, doi:10.1016/j.ijhm.2018.11.010.
- [5] M. Song, B. M., Noone, and R. J. Han, "An examination of the role of booking lead time in consumers' reactions to online scarcity messages," *International Journal of Hospitality Management*, vol. 77, Jan. 2019, pp. 483-491, doi:10.1016/j.ijhm.2018.08.012.
- [6] R. B. Cialdini, *Influence: Science and Practice* (Vol. 4). Boston, MA: Pearson, 2009.
- [7] W. E. Jang, Y. J. Ko, J. D. Morris, and Y. Chang, "Scarcity message effects on consumption behavior: Limited edition product considerations," *Psychology & Marketing*, vol. 32, no. 10, Oct. 2015, pp. 989-1001, doi:10.1002/mar.20836.
- [8] R. Roy, and P. Sharma, "Scarcity appeal in advertising: exploring the moderating roles of need for uniqueness and message framing," *Journal of Advertising*, vol. 44, no. 4, Mar. 2015, pp. 349-359, doi:10.1080/00913367.2015.1018459.
- [9] P. C. S. Wu, and W. K. Lo, "Effects of product scarcity: The mediating role of consumer need for uniqueness and conformity," *International Journal of Business Environment*, vol. 9, no. 1, Jun. 2017, pp. 34-50, doi:10.1504/IJBE.2017.084702.
- [10] J. Guo, L. Xin, and Y. Wu, "Arousal or not? The effects of scarcity messages on online impulsive purchase," in F. H. Nah, and C. H. Tan (eds.), *Proceedings of the International Conference on HCI in Business, Government, and Organizations*, Jul. 2017, pp. 29-40, doi:10.1007/978-3-319-58484-3_3. Cham, Switzerland: Springer.
- [11] Z. Zhang, Q. Ye, and R. Law, "Determinants of hotel room price: An exploration of travelers' hierarchy of accommodation needs," *International Journal of Contemporary Hospitality Management*, vol. 23, no. 7, Oct. 2011, pp. 972-981, doi:10.1108/09596111111167551.
- [12] N. M. Suki, "A descriptive investigation of Malaysian Internet users' adoption of online shopping," *Asia-Pacific Journal of Information Technology and Multimedia*, vol. 3,

- no. 1, 2006, pp. 127-138, available at: <http://ejournal.ukm.my/apjitm/article/view/1268>
- [13] W. K. Tan, "From fantasy to reality: A study of pre-trip planning from the perspective of destination image attributes and temporal psychological distance," *Service Business*, vol. 12, no. 1, Mar. 2018, pp. 65-84, doi:10.1007/s11628-017-0337-6.
- [14] D. J. O'Keefe, "Message properties, mediating states, and manipulation checks: Claims, evidence, and data analysis in experimental persuasive message effects research," *Communication Theory*, vol. 13, no. 3, Aug. 2003, pp. 251-274, doi:10.1111/j.1468-2885.2003.tb00292.x.
- [15] R. Law, "Disintermediation of hotel reservations: The perception of different groups of online buyers in Hong Kong," *International Journal of Contemporary Hospitality Management*, vol. 21, no. 6, Aug. 2009, pp. 766-772, doi:10.1108/09596110910976007.
- [16] B. G. Tabachnick, and L. S. Fidell, *Using Multivariate Statistics* (3rd Edition). New York, NY: Harper Collins, 1996.
- [17] A. S. Suresh, and A. Biswas, "A study of interrelation of psychological factors and demographic variables and its impact on compulsive buying behavior: A marketing perspective," *Journal of Business and Retail Management Research*, vol. 13, no. 3, Apr. 2019, pp. 58-69, doi: 10.24052/JBRMR/V13IS03/ART-06.
- [18] M. Fenton-O'Creevy, S. Dibb, and A. Furnham, "Antecedents and consequences of chronic impulsive buying: Can impulsive buying be understood as dysfunctional self-regulation?," *Psychology & Marketing*, vol. 35, no. 3, Feb. 2018, pp. 175-188, doi:10.1002/mar.21078.
- [19] H. Dittmar, "Compulsive buying—a growing concern? An examination of gender, age, and endorsement of materialistic values as predictors," *British Journal of Psychology*, vol. 96, no. 4, Nov. 2005, pp. 467-491, doi: 10.1348/000712605X53533.
- [20] U. Akram, P. Hui, M. Khan, C. Yan, and Z. Akram, "Factors affecting online impulse buying: Evidence from Chinese social commerce environment," *Sustainability*, vol. 10, no. 2, Jan. 2018, pp. 352: 1-28, doi:10.3390/su10020352.