

Washington University in St. Louis

Washington University Open Scholarship

Mechanical Engineering Design Project Class

Mechanical Engineering & Materials Science

Fall 2021

MEMS 411: ASME Soccer Robot

Braden Arango

Washington University in St. Louis

Brendan Otani

Washington University in St. Louis

Florie Markwell

Washington University in St. Louis

Follow this and additional works at: <https://openscholarship.wustl.edu/mems411>



Part of the [Mechanical Engineering Commons](#)

Recommended Citation

Arango, Braden; Otani, Brendan; and Markwell, Florie, "MEMS 411: ASME Soccer Robot" (2021).

Mechanical Engineering Design Project Class. 175.

<https://openscholarship.wustl.edu/mems411/175>

This Final Report is brought to you for free and open access by the Mechanical Engineering & Materials Science at Washington University Open Scholarship. It has been accepted for inclusion in Mechanical Engineering Design Project Class by an authorized administrator of Washington University Open Scholarship. For more information, please contact digital@wumail.wustl.edu.



Washington University in St. Louis

JAMES MCKELVEY SCHOOL OF ENGINEERING

FL21 MEMS 411 Mechanical Engineering Design Project

ASME Soccer Remote-Operated Vehicle

Design Instructor: Dr. Jackson Potter

Submission Date: Friday, December 10, 2021

This project was based off of a variation of the ASME Soccer Robot Competition, where 5 teams were tasked with creating a soccer robot to compete with. The main objective for each team was to create a remote-controlled robot with an integrated shooting mechanism that was capable of shooting a tennis ball, with accuracy, into a goal. A design process was used to create this robot from scratch, where multiple concepts were created and tested through mock-ups and prototypes to better understand the problem at hand. Throughout this process, three main prototype goals were prioritized: the ability to drive around the field in less than 17 seconds, make 5/10 shots from the mid-line, and capture a ball within 2 seconds 8/10 times. With these goals in mind, as well as multiple user needs listed on page 10, a final prototype was constructed and competed in the competition, winning 3rd place overall. Overall, our prototype achieved two out of the three goals. The shooting mechanism was very efficient with capturing and shooting the ball, but the final product lacked the speed to make it around the field in less than 17 seconds.

ARANGO, Braden

MARKWELL, Florie

OTANI, Brendan

Contents

List of Figures	2
List of Tables	2
1 Introduction	3
2 Problem Understanding	3
2.1 Existing Devices	3
2.2 Patents	5
2.3 Codes & Standards	9
2.4 User Needs	9
2.5 Design Metrics	10
2.6 Project Management	11
3 Concept Generation	13
3.1 Mockup Prototype	13
3.2 Functional Decomposition	15
3.3 Morphological Chart	16
3.4 Alternative Design Concepts	17
4 Concept Selection	20
4.1 Selection Criteria	20
4.2 Concept Evaluation	20
4.3 Evaluation Results	21
4.4 Engineering Models/Relationships	21
5 Concept Embodiment	22
5.1 Initial Embodiment	23
5.2 Proofs-of-Concept	26
5.3 Design Changes	27
6 Design Refinement	27
6.1 Model-Based Design Decisions	27
6.2 Design for Safety	29
6.3 Design for Manufacturing	32
6.4 Design for Usability	33
7 Final Prototype	35
7.1 Overview	35
7.2 Documentation	35
Bibliography	37

List of Figures

1	A robot from the 2010 mid-size Robocup cup soccer league: (Teams RFC Stuttgart and The Tribots) [1]	3
2	Gameplay screenshot of a RoboCup Junior competition: (Team 97% Robotics aka the middle robot) [2]	4
3	The underside of a Roomba: (From Irobot) [3]	5
4	Patent Image for Omnidirectional Wheel [4]	6
5	Patent Images for Soccer and fighting robot, and driving and operating device of the robot [5]	7
6	Additional Patent Images for Soccer and fighting robot, and driving and operating device of the robot [5]	8
7	Gantt chart for design project	12
8	Photograph of Mockup Prototype	13
9	Photograph of Mockup Prototype	13
10	Photograph of Mockup Prototype	14
11	Function tree for ROV, hand-drawn and scanned	15
12	Morphological Chart for ROV	16
13	Sketches of ROV-inator	17
14	Sketches of the bottle	18
15	Sketches of circular ROV concept, the Disc-ick	19
16	Analytic Hierarchy Process (AHP) to determine scoring matrix weights	20
17	Weighted Scoring Matrix (WSM) for choosing between alternative concepts	20
18	The final velocity of the tennis ball after launching using the Conservation of Momentum	22
19	Velocity of an independent wheel based on surface and angular velocity	22
20	Assembled projected views with overall dimensions	23
21	Assembled isometric view with bill of materials (BOM)	24
22	Exploded view with callout to BOM	25
23	A calculation of the reaction forces at the wheels of our soccer robot.	29
24	Heat Map of Risks Listed	31
25	Drawings of design update from four individual spacers to two long spacers, bottom view and front view	32
26	Possible 3D printed part for updated spacer	33
27	Overhead view of final ROV	35
28	Shooting Mechanism and Backboard	36
29	Side view of final ROV	36

List of Tables

1	Interpreted Customer Needs	10
2	Target Specifications	11

1 Introduction

This project is aimed towards creating a working Remote Operated Vehicle (ROV) with a mechanical system designed to hit tennis balls into a goal. This is part of the ASME Soccer Robot Competition being held in the MEMS 411 Mechanical Engineering Design Project class. The beginning goal is to develop an understanding of the potential problems and certain specifications that will be needed to begin proceeding with this project.

This is done through the research that has been done in this assignment on existing devices, pre-existing patents, and standards. It is important to address previously designed equipment and devices to progress with our own in a more successful manner. The needs of our customer were also evaluated and taken into account, providing more direct specifications for the design of the ROV as seen on the Interpreted User Needs and Design Metrics charts.

2 Problem Understanding

2.1 Existing Devices

Soccer robots are built annually for competitions around the globe by everyone from students to employed engineers. Robocup is one of the most popular annual soccer robot competitions with multiple leagues of different sized robots. The mid-size robots and Robocup junior robots are like what we expect to build. The final existing device, which is the least similar, is a Roomba. Though, it can't play soccer with a shooting mechanism, it's one of the most popular robots around us and contains design components that fit the scope of this project.

2.1.1 Existing Device #1: Mid-size RoboCup Robot

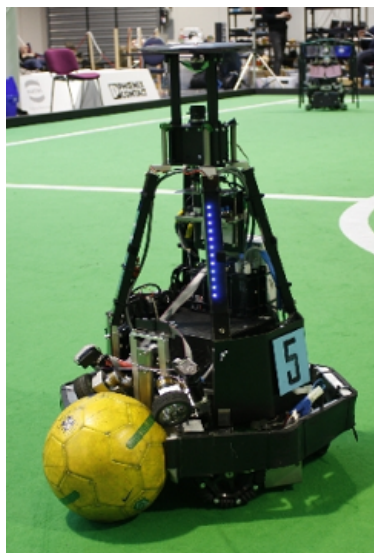

Figure 1: A robot from the 2010 mid-size Robocup cup soccer league: (Teams RFC Stuttgart and The Tribots) [1]

Link: <http://roboearth.ethz.ch/robocup-german-open-2010/index.html>

Description: This autonomous soccer robot played in the 2010 mid-size robocup soccer league. Though, taller than our allowable design, the shooting mechanism, general mobility, and body shape are useful design components. To dribble, the wheels touching the ball freely rotate as the robot moves. To shoot, a mechanism shoots the ball from the opening, where it would glide off the wheels of the robot. This is better seen in the YouTube video. A couple design features include the half-exposed omni wheels, the cone shape design of the robot, and an octagon bumper. All of this clearly displayed in the youtube video here, <https://www.youtube.com/watch?v=agHBb8KCTZg>.

2.1.2 Existing Device #2: Robocup Junior robot

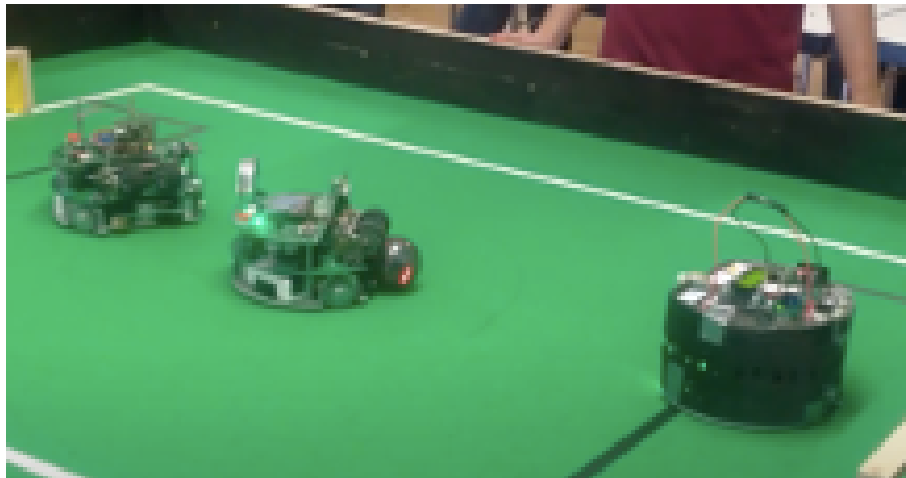

Figure 2: Gameplay screenshot of a RoboCup Junior competition:
(Team 97% Robotics aka the middle robot) [2]

Link: <https://www.youtube.com/watch?v=vineEOHeYD6w>

Description: The smaller autonomous robots shown here are playing a qualifying game for the 2014 RoboCup Junior competition in Germany. The robot uses wheels that act like a roller to capture and keep the ball while dribbling. A launching mechanism housed in the center of the body launches the ball. The driving wheels near the mouth of the robot contain smaller perpendicular wheels along their rim, which aid in rotating.

2.1.3 Existing Device #3: Roomba



Figure 3: The underside of a Roomba: (From Irobot) [3]

Link: <https://store.irobot.com/default/roomba-vacuuming-robot-vacuum-irobot-roomba-i3-3150/i315020.html>

Description: A Roomba is small autonomous robotic vacuum built by IRobot. Some design components of interest include its shape and wheels. A Roomba has 3 total wheels with 2 propelling wheels that move in a line, and 1 smaller wheel that is free to rotate the device. The circular shape of the body enables the device to move easily in corners.

2.2 Patents

2.2.1 Omnidirectional wheel (US3789947A)

This patent includes a possible option for the component used for traversing the play field [4]. The Omnidirectional Wheel is a substantially rigid wheel that contains several circumferential rim segments that allows immediate lateral movement, perpendicular to the typical forward driving direction of a wheel. If used, this device can eliminate the need for a steering element in the ROV.

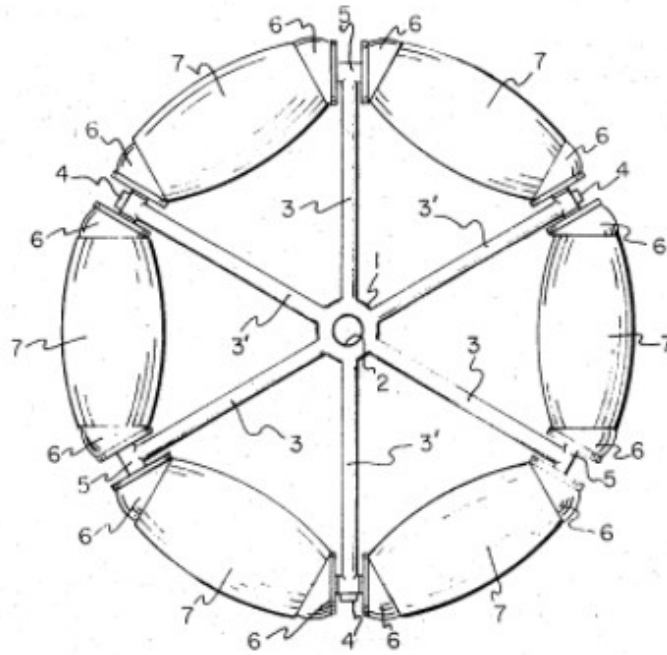

FIG. 1.

Figure 4: Patent Image for Omnidirectional Wheel [4]

2.2.2 Soccer and fighting robot, and driving and operating device of the robot7463001B2

This patent describes all parts of the soccer and fighting robot created and patented by Fumiaki Tsurukawa [5]. The robot features an equilateral triangle base for stability and appears to have three wheels, one on each midpoint of the sides of the equilateral triangle base. The wheels used appear to be omnidirectional.

Fig. 2

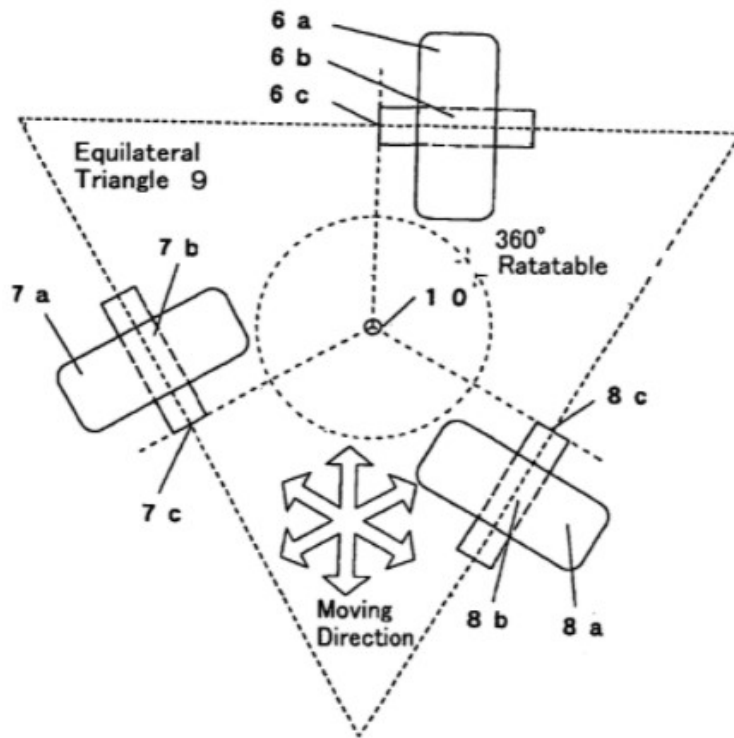

Fig. 3

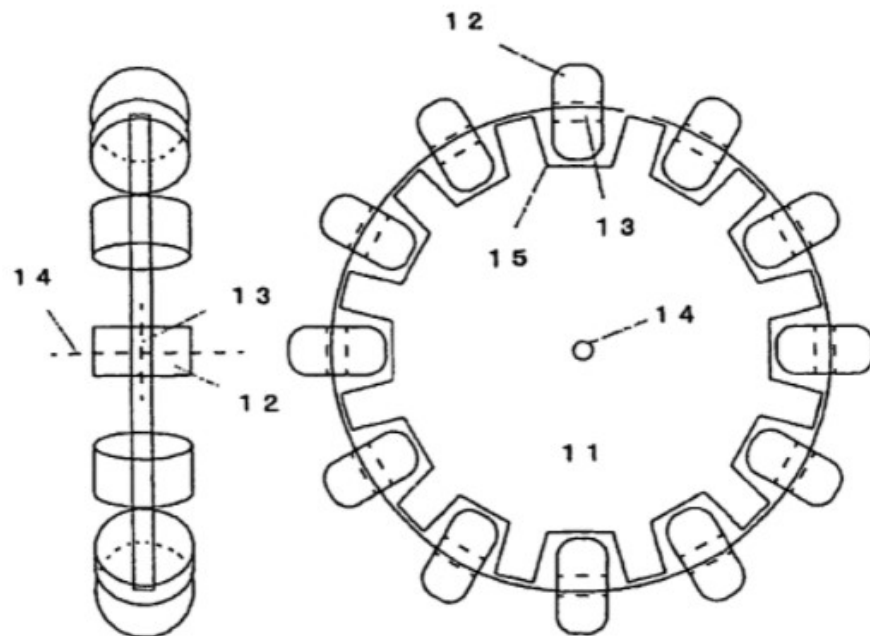

Figure 5: Patent Images for Soccer and fighting robot, and driving and operating device of the robot [5]

Fig. 4

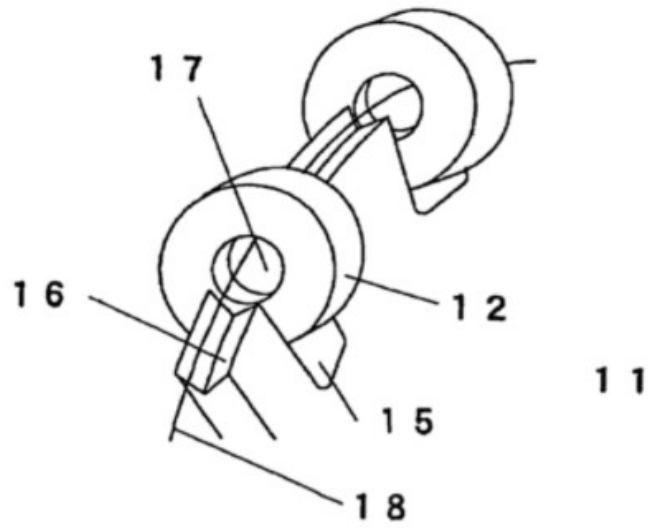

Fig. 5

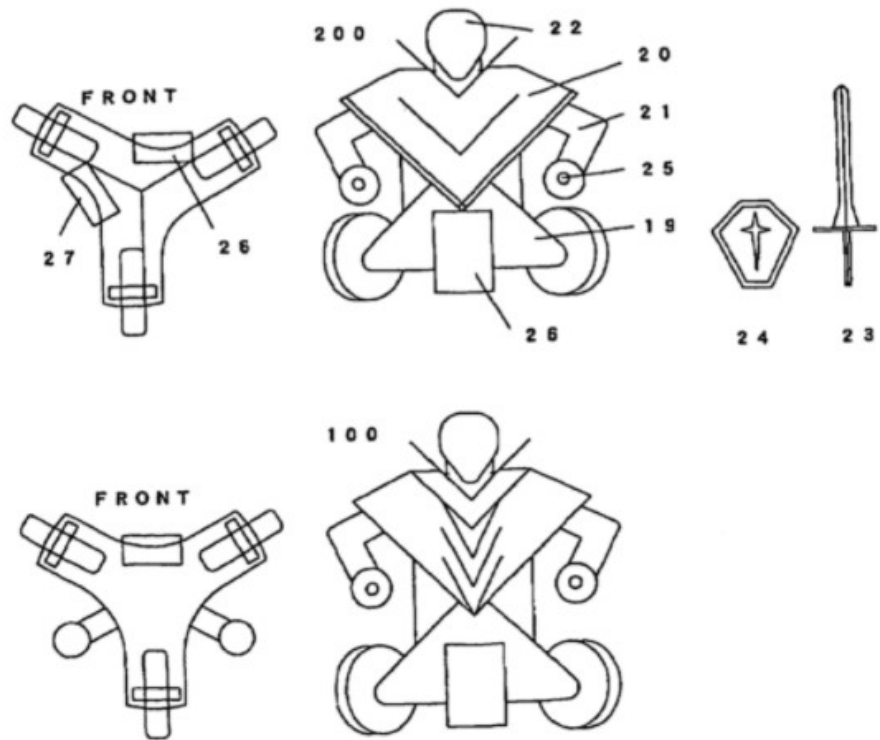

Figure 6: Additional Patent Images for Soccer and fighting robot, and driving and operating device of the robot [5]

2.3 Codes & Standards

2.3.1 Lithium Ion Battery - Safety (IEC 61960)

This International Standard sets up the criteria for performance testing, designations, markings, dimensions, and other requirements for portable application for a lithium-ion battery (also called a secondary lithium cell). It makes sure that the battery is in a safe condition to be used safely without malfunction while in a non-damaged state, protecting the user from any harm that could come from a defective battery while insuring the battery will efficiently work as intended.

2.3.2 Test Methods for Stress Relaxation for Materials and Structures (E328)

This standard requires a series of stress tests to be performed to determine if the material in the mechanical parts used can relax when high-concentrations of stress are applied to them. This is most likely relevant to the suspensions and other moving parts that will be potentially added to our ROV, allowing us to better speculate the possibilities it will have in the playing field.

2.4 User Needs

A customer interview was conducted and interpreted to create a finite list of needs that the customer desires in the final design of the ROV.

2.4.1 Customer Interview

Interviewee: Sam Hudson

Location: Wilson 214, Washington University in St. Louis, Danforth Campus

Date: September 10th, 2021

Setting: A group interview between Sam and 5 teams took place in Wilson 214. The meeting started with the Sam explaining rule changes to the official ASME rules, before a classic Q/A style interview. The interview lasted ~1 hour.

Interview Notes:

Even though you're not driving the ROV, do have customer preferences on design concepts that affect the ROV's drive?

- No, you should think of me less as a customer, and more as a referee. Decisions that affect the driver and the ROVs performance are up to the groups. Make sure to explain any needs.

Can equipment be piled in the 50x50x50 cm³ cube?

- Yes, the only requirement is that all equipment and the robot fit. Though, be mindful of the 1-minute set up time.

Once the robot is out of the sizing box, can parts open that make the robot larger than the sizing box?

- Yes, but be mindful of the 1 minute set up time before game play. Also, parts that protrude out of the robot are susceptible to breaking.

Will other people be driving the ROV, say children?

- No children will be driving the ROV, only your team members. I recommend common sense safety, so be aware of pinching parts, issues with long hair, etc.

How aggressive is too aggressive in gameplay?

- The rules are the same as soccer, so calls on players intentions are up to the referees' discretion. The rule is that all plays must be directed towards the ball and not other players.

2.4.2 Interpreted User Needs

The following list contain definitive things that the designers will look to incorporate into the design of the product. The needs were interpreted from the ASME Soccer Competition rules and the customer interview with Sam Hudson.

Table 1: Interpreted Customer Needs

Need Number	Need	Importance
1	The ROV and all equipment fits in a 50 x 50 x 50 cm cube	5
2	The ROV is operable on specified field material	5
3	The ROV has long lasting battery life	3
4	The ROV is aesthetically pleasing	2
5	The ROV must be setup quickly	5
6	The ROV does not pose any danger	4
7	The ROV is durable	4
8	The ROV is lightweight and portable	3
9	The ROV is user-controlled	4
10	The ROV is easy to drive	2
11	The ROV maneuvers easy on the field	5
12	The ROV has replaceable parts	2
13	The ROV passes stress standards	4

Most of the listed needs are of high importance because of their correlation to the rules of the competition. Sam was relatively clear on what aspects of the design would meet rule requirements.

2.5 Design Metrics

For some of the interpreted user needs, quantitative benchmarks can be set to deepen the understanding of the user need and help us achieve certain specifications. These quantitative metrics are listed below.

Table 2: Target Specifications

Metric Number	Associated Needs	Metric	Units	Acceptable	Ideal
1	3	Rechargeable battery life	mins	5	120
2	1	Total volume of ROV	cm^3	< 125000	< 1260
3	5	Setup time	sec	< 60	< 40
4	8	Total weight of ROV	N	< 133	< 67
5	9	Controlling mechanism	type	Tether	Remote
6	13	Stress standard E328	binary	Pass	Pass

2.6 Project Management

The Gantt chart in Figure 7 gives an overview of the project schedule.

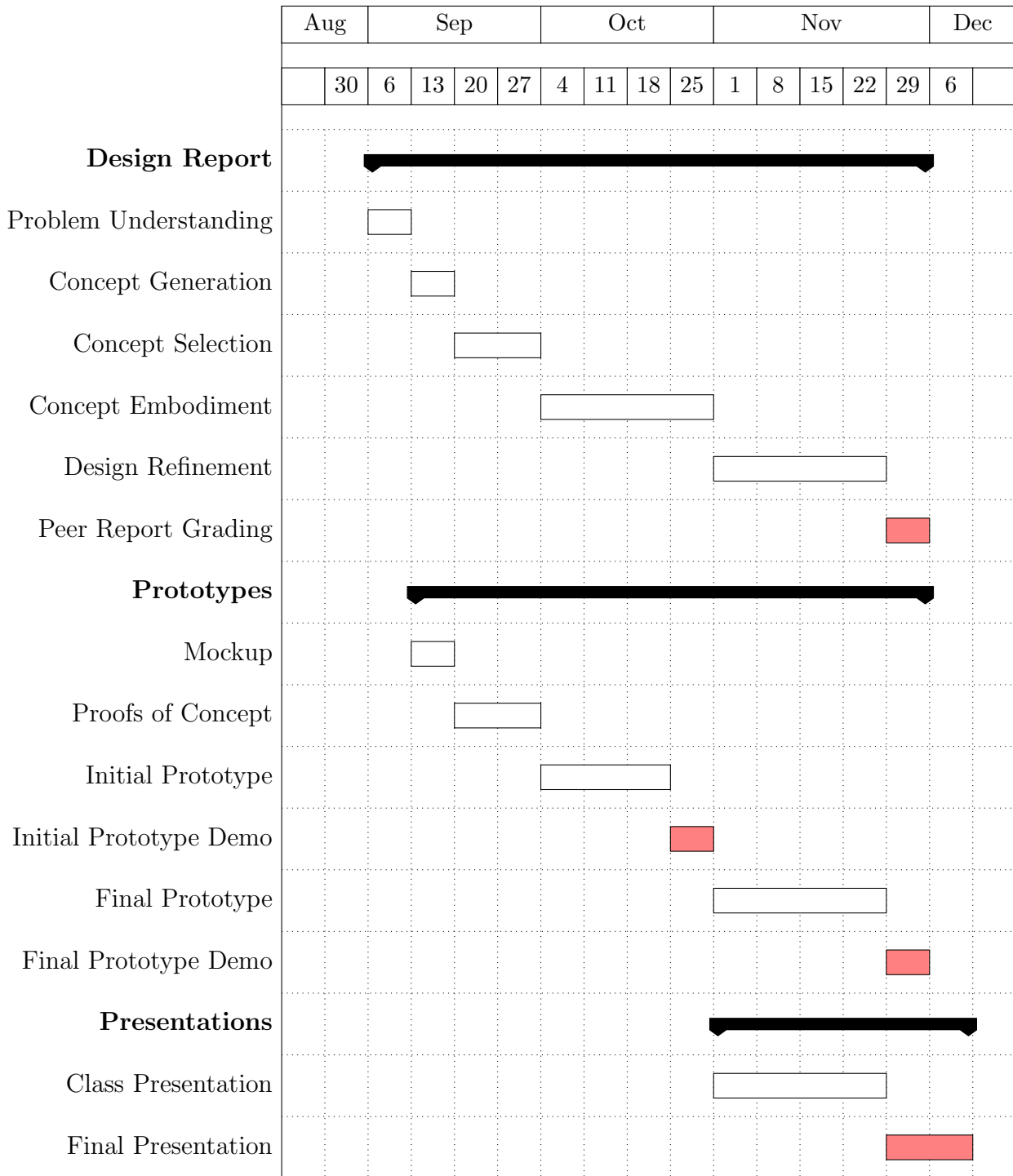

Figure 7: Gantt chart for design project

3 Concept Generation

3.1 Mockup Prototype

Our team completed a mock up of a potential wheel and axle set up. As seen in Fig. 8 there are two center wheels that move the body linearly. By moving the two linear wheels in opposite directions the body should rotate. On the four corners are wheels with more degrees of freedom that aid in rotating the body. Completing the mock up gave us an idea on the type of wheels and attaching the wheels to the body. It revealed new problems, such as how to attach the supporting wheels to the body. Overall, we did not focus on the body, but were inspired by the size of the body and chassis. Specifically about optimal body shape for game play as well as the placement of extra pieces, such as the Popsicle stick wings seen in the figures below. Here, the wings act as extenders that can grab and redirect one or multiple balls in game play.

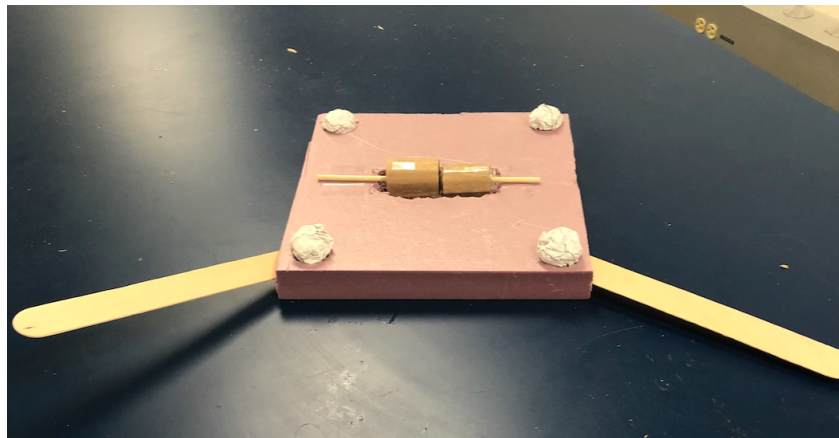

Figure 8: Photograph of Mockup Prototype

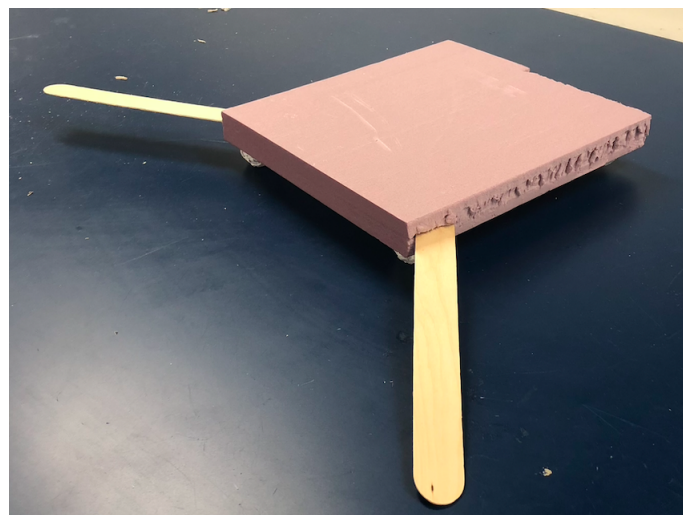

Figure 9: Photograph of Mockup Prototype

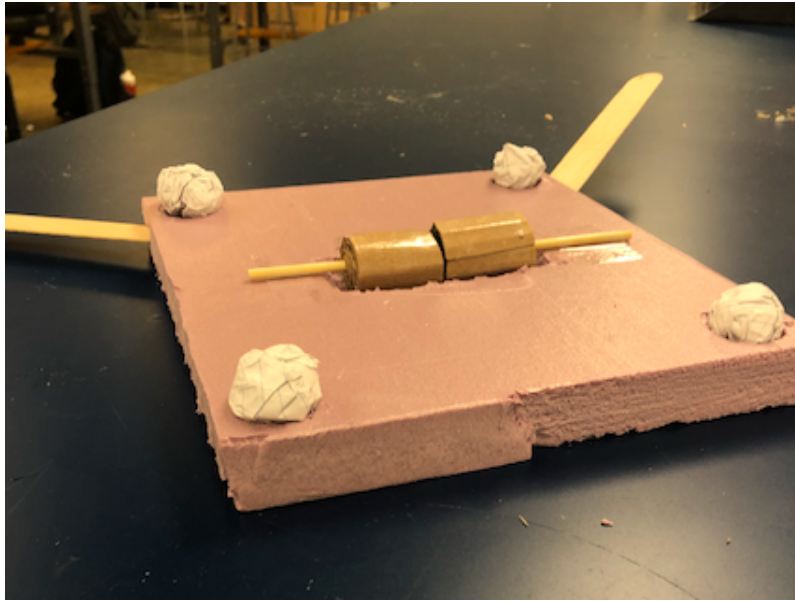

Figure 10: Photograph of Mockup Prototype

3.2 Functional Decomposition

Below is the function tree. It contains the main aspects that will be focused on when building of the ROV begins. It describes the main function desired of the ROV, as well as multiple sub-functions to achieve the main goal of the primary function.

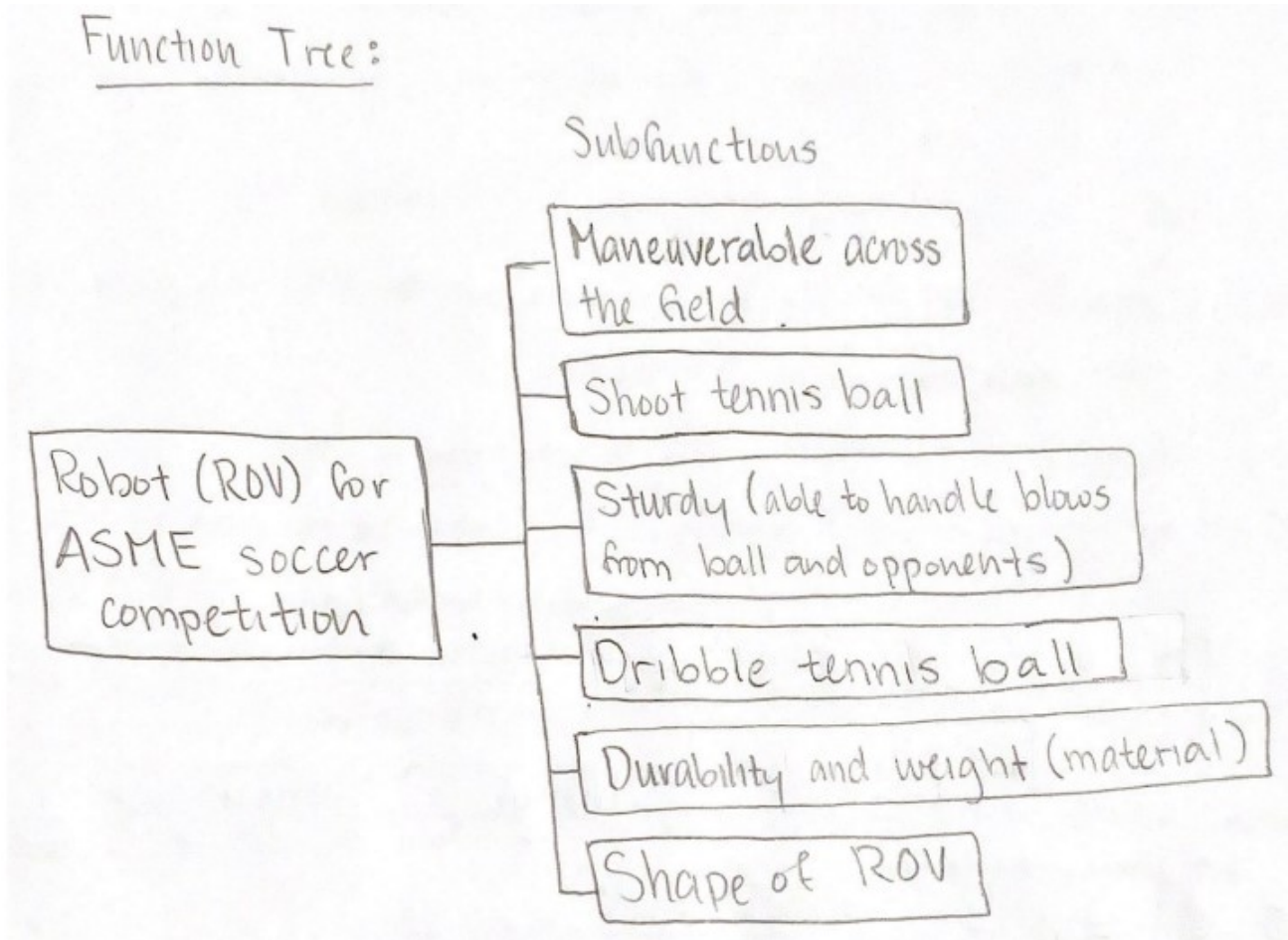

Figure 11: Function tree for ROV, hand-drawn and scanned

3.3 Morphological Chart

Below is the morphological chart of the combined designs from each member of our group. There is an emphasis on the functioning of the ROV with priority over movement and tennis ball control, with added sections to aid in improving the performance of the ROV in the competition.













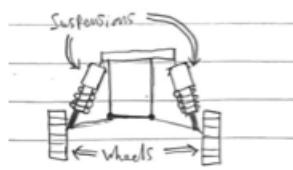
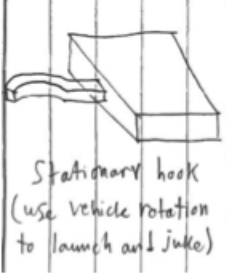
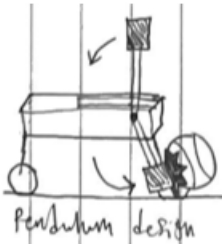

Shape of ROV base	 <p>pointed</p>	 <p>Trapezoidal</p>	 <p>Circle</p>	
Wheel placement	<p>rotating axle</p> 	<p>3 wheel</p>  <p>rotating wheel linear wheels</p>	<p>Omni-wheels</p> 	 <p>Suspensions Wheels</p>
Scoring / Controlling Mechanism	 <p>Stationary hook (use vehicle rotation to launch and judge)</p>	 <p>Pendulum design</p>	 <p>Spring loaded plate</p>	<p>Top-down view</p>  <p>Rigid extremities (turn to hit ball)</p>
Dribbling the ball	<p>roller</p>  <p>(spin w/ ball)</p>	 <p>mounted actuator</p>	<p>Top-down view</p>  <p>Spring-loaded arm</p>	<p>push plate</p> 
Sturdy body to resist impacts	 <p>Metal</p>	 <p>Wood</p>	 <p>foam cushion</p>	

Figure 12: Morphological Chart for ROV

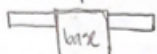
3.4 Alternative Design Concepts

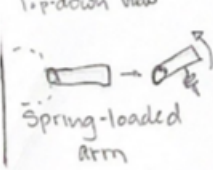
3.4.1 The ROV-inator

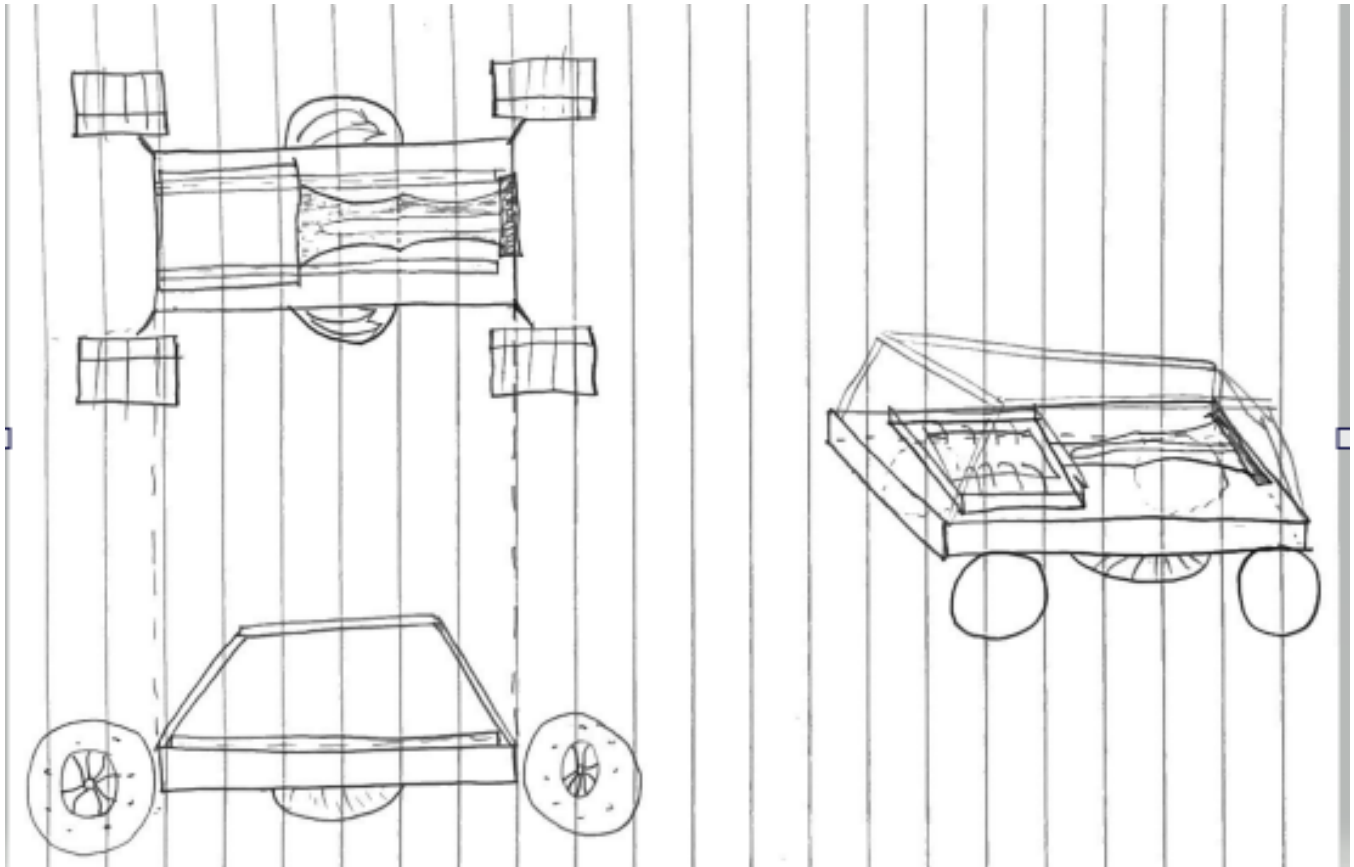

Figure 13: Sketches of ROV-inator

Solutions from morph chart:

1. Trapezoidal type of base
2. Traditional 4-wheel placement
3. Spring-loaded plate (blockers)
4. Mounted actuator (under-mounted disc)
5. Foam Cushion would be desirable

Description: The circuit board will be on top of the base of the ROV. When a button is pressed, the spring-loaded blockers will shoot out the front end, hitting the ball in a desired direction. While extended, it acts as stagnant blockers that can redirect a tennis ball that hits either side of it with the stored energy in the springs from impact. On the sides are rotating disks that can launch the ball in a forward motion when side-swiped, allowing further domination of the playing field. It comes with a remote receiver that connects to a blue-tooth controller for remote operation.

3.4.2 The bottle AKA Lana

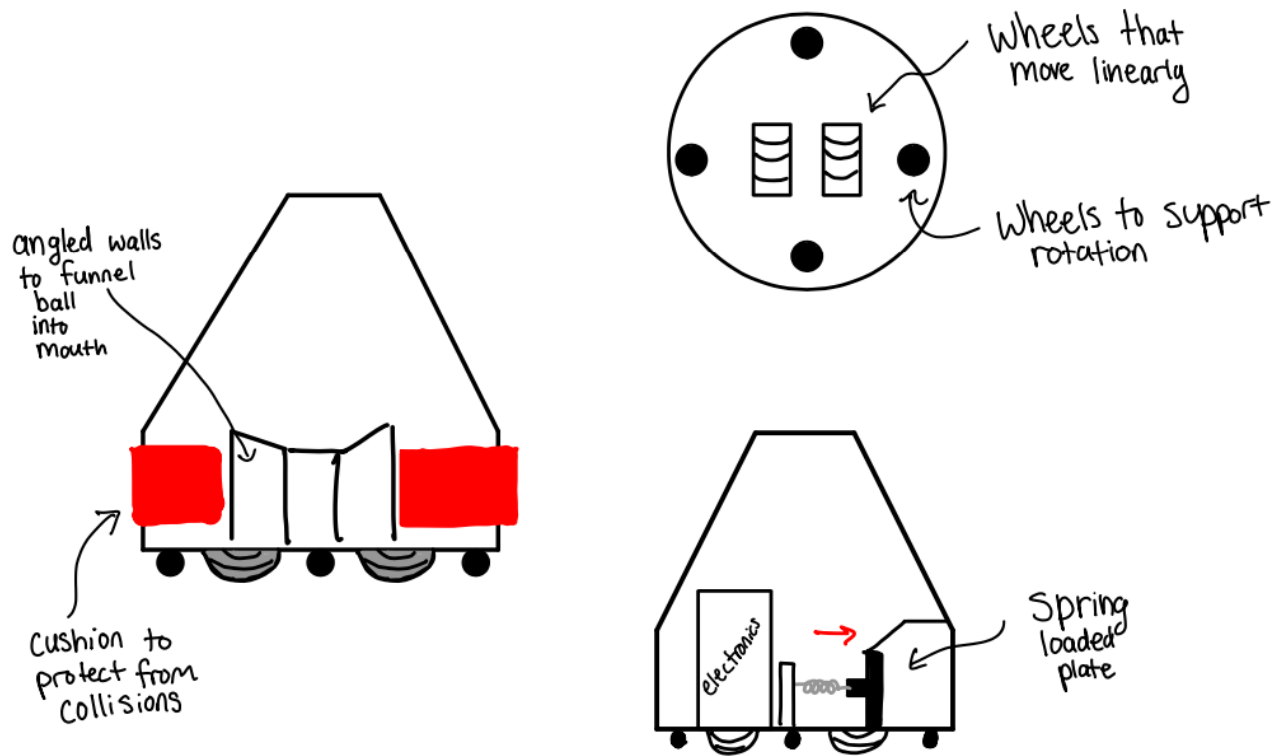

Figure 14: Sketches of the bottle

Solutions from morph chart:

1. Circular base
2. Protective cushion surrounding the body
3. Wheel combination of linear driving wheels and rotating supporting wheels
4. Spring loaded push plate as a shooting mechanism

Description: The angled walls funnel the tennis ball into the spring loaded plate, which shoots the ball. The push plate and angled walls also support dribbling the ball. (A roller could be added to further increase robots ability to freely dribble the ball. The spring will be reset by a possible servo motor. The cone shaped body encourages any balls that hit the body to roll onto the ground. The widest part of the ROV is a foam cushion to protect the hardware and main body from robot collisions. The base of the robot is circular and contains two separate types of wheels. The larger center wheels translate the robot linearly. The outer wheels have more degrees of freedom and support rotation.

3.4.3 The Disc-ick

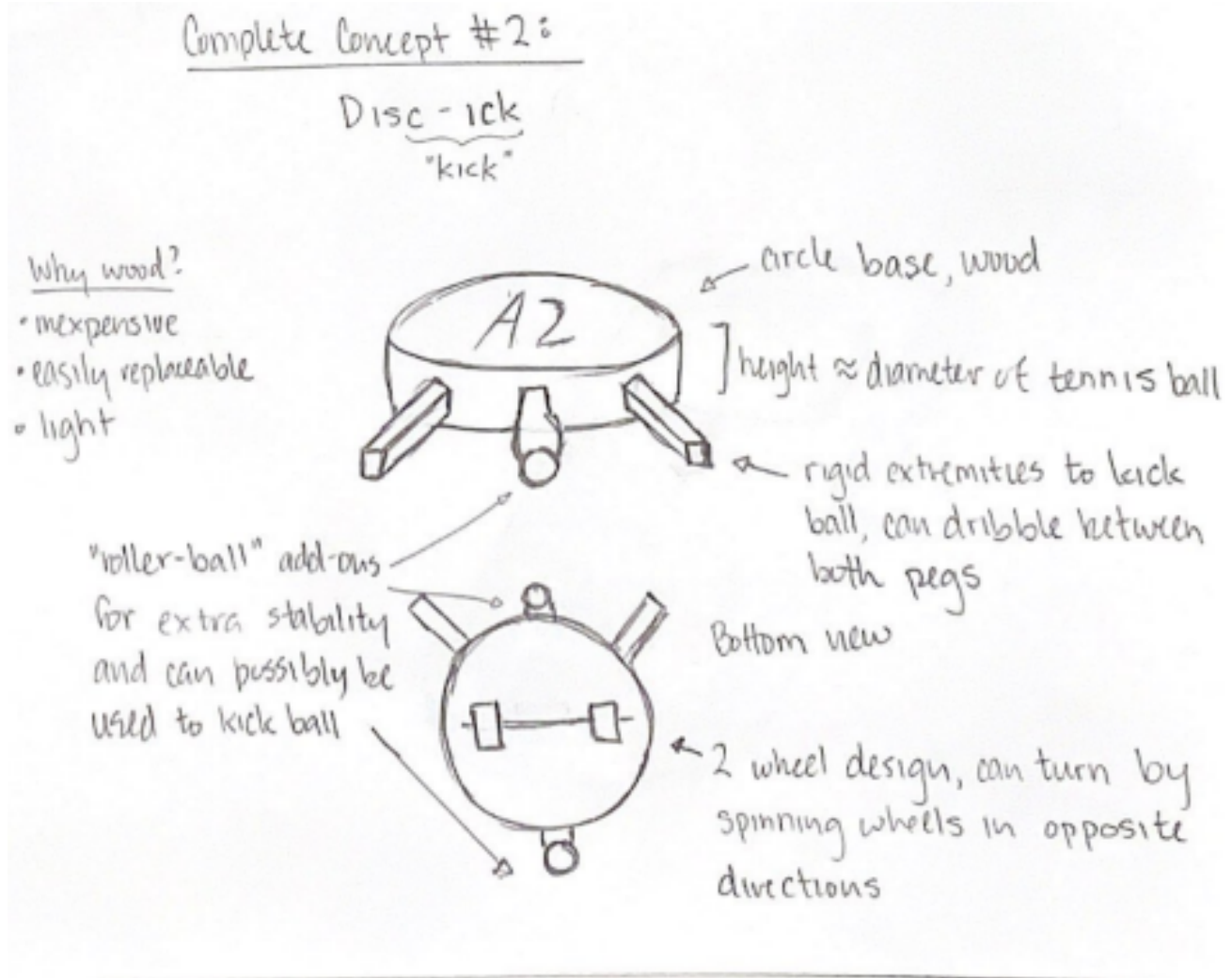

Figure 15: Sketches of circular ROV concept, the Disc-ick

Description: The ROV has a wooden circular base. Looking from below, the Disc-ick features a two-linear wheel and two-roller-ball wheel design. The two-linear wheel concept allows for the ROV to move forward and backward, and when the wheels rotate in opposite directions, the Disc-ick is able to rotate. The two roller-ball wheels offer support to avoid toppling forward or backward while in motion. The roller-ball design allows for both linear motion and rotational motion about the center axis of the ROV. The Disc-ick has two rigid extremities protruding toward the front of the ROV to be used for dribbling the tennis ball around the field and with a swift rotation, shoot the tennis ball into the opposing goal. The Disc-ick is approximately as tall as a tennis ball to ensure that tennis balls don't easily roll over it. The circuit board and receiver (not pictured) are placed and protected (by a cover) on top of the base plate. The ROV is controlled using a remote controller (not pictured).

4 Concept Selection

4.1 Selection Criteria

The Analytical Hierarchy Process (AHP) is used to find the weights of each of the criterion when creating the ROV. The five criteria are ease of construction, maneuverability, reliability of the scoring mechanism, speed of the vehicle, and overall cost.

	Ease of Construction	Maneuverability	Reliability	Speed	Cost		Row Total	Weight Value	Weight (%)
Ease of Construction	1.00	0.20	0.14	0.33	3.00		4.68	0.09	9.29
Maneuverability	5.00	1.00	1.00	3.00	5.00		15.00	0.30	29.81
Reliability of scoring mechanism	7.00	1.00	1.00	3.00	9.00		21.00	0.42	41.73
Speed	3.00	0.33	0.33	1.00	3.00		7.67	0.15	15.24
Cost	0.33	0.20	0.11	0.33	1.00		1.98	0.04	3.93
Column Total:							50.32	1.00	100.00

Figure 16: Analytic Hierarchy Process (AHP) to determine scoring matrix weights

4.2 Concept Evaluation

A Weighted Scoring Matrix (WSM) is used to choose between the determined alternative design concepts. The weight values for each of the criterion are found in the AHP and inputted here to ensure an objective weighted scale.





Alternative Design Concepts		TheROV-inator		The Disc-ick		Lana		Concept #4	
									
Selection Criterion	Weight (%)	Rating	Weighted	Rating	Weighted	Rating	Weighted	Rating	Weighted
Ease of Construction	9.29	3	0.28	5	0.46	4	0.37	1	
Maneuvarability	29.81	3	0.89	4	1.19	4	1.19	5	
Reliability of scoring mechan	41.73	4	1.67	1	0.42	5	2.09	3	
Speed	15.24	4	0.61	2	0.30	2	0.30	3	
Cost	3.93	2	0.08	5	0.20	3	0.12	3	
Total score		3.530		2.576		4.073		0.000	
Rank		2		3		1		4	

Figure 17: Weighted Scoring Matrix (WSM) for choosing between alternative concepts

4.3 Evaluation Results

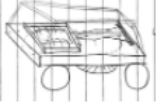
The ROV-inator received average scores of 3 on ease of construction and maneuverability, slightly lower than average on cost because of an electronic shooting mechanism. The reliability of the scoring mechanism and speed of the ROV-inator earned it a higher-than-average score of 4 for each of these criteria. The Disc-ick received very high scores of 5 for both ease of construction and cost because of its inherently simpler design and use of less materials and electronics. The maneuverability for the Disc-ick was considered higher-than-average because of its ability to rotate in place, something that the ROV-inator is unable to do. It was determined that the Disc-ick would lack in the speed department as well as the reliability of the scoring mechanism because it relies solely on its maneuverability/movement to hit the ball into the opposing goal (absence of a scoring mechanism). Lana, or “the bottle,” scores better in ease of construction and maneuverability compared to the ROV-inator and has a very reliable scoring mechanism. It is predicted to have a slower speed and will cost slightly less than the ROV-inator, but more than the Disc-ick. Overall, Lana has the largest total score and is the best of the alternative concepts.

4.4 Engineering Models/Relationships

The first engineering model is focused on the DC motor used to turn the wheels of our robot. The back wheels will likely propel the robot. Below is a solid mechanics problem to determine the torque on a shaft connected to a rotating motor of a given power.

$$\begin{aligned} \text{Power} &= \text{Torque} * \text{angular velocity} \\ P &= (T)(RPM)\frac{2\pi}{60} \\ T &= \frac{60P}{(RPM)(\pi)} \end{aligned}$$

This relationship connects the power of our motor to the speed of our vehicle. Given a desired number of rotations, we can determine the torque on the shaft which ultimately rotates the wheels. This is important for picking motors and understanding the forces inside our robot.

The second engineering model incorporates the conservation of momentum with the ball-launcher. It can be useful in determining how much total energy would be needed to be transferred from the motors to the tennis ball to achieve a certain velocity when taking a shot, as seen in the figure below:

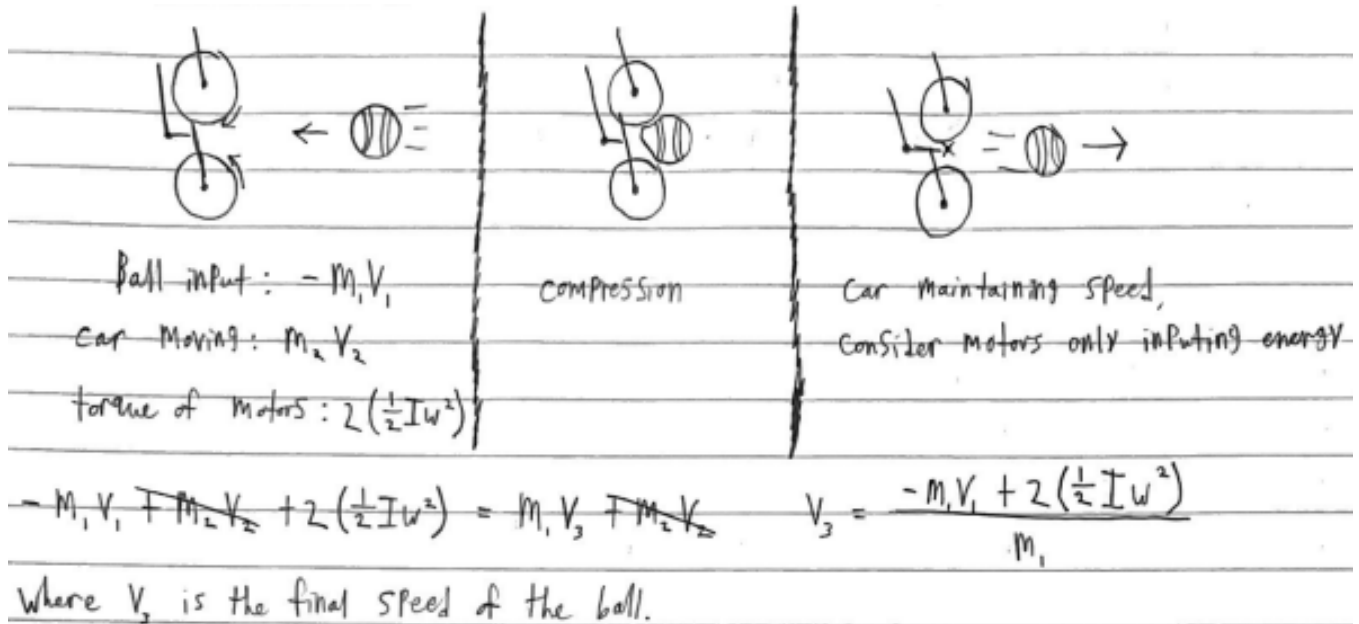

Figure 18: The final velocity of the tennis ball after launching using the Conservation of Momentum

The third engineering model shows information regarding the frictional force and velocity of a singular wheel on the ROV. Knowing this information for one wheel will allow us to know the speed of the whole ROV on various surfaces; being dependant on the angular velocity of the wheel. This correlates directly with the first model, as figuring out the angular velocity from the total input of power allows us to know its final linear speed.

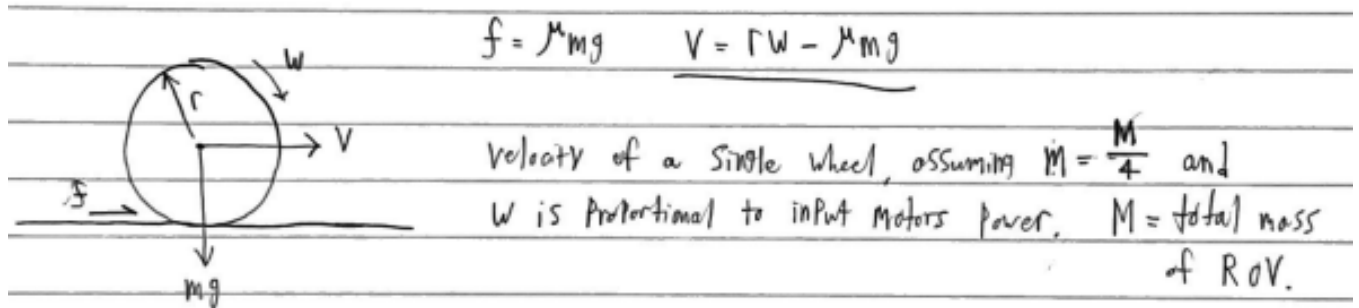
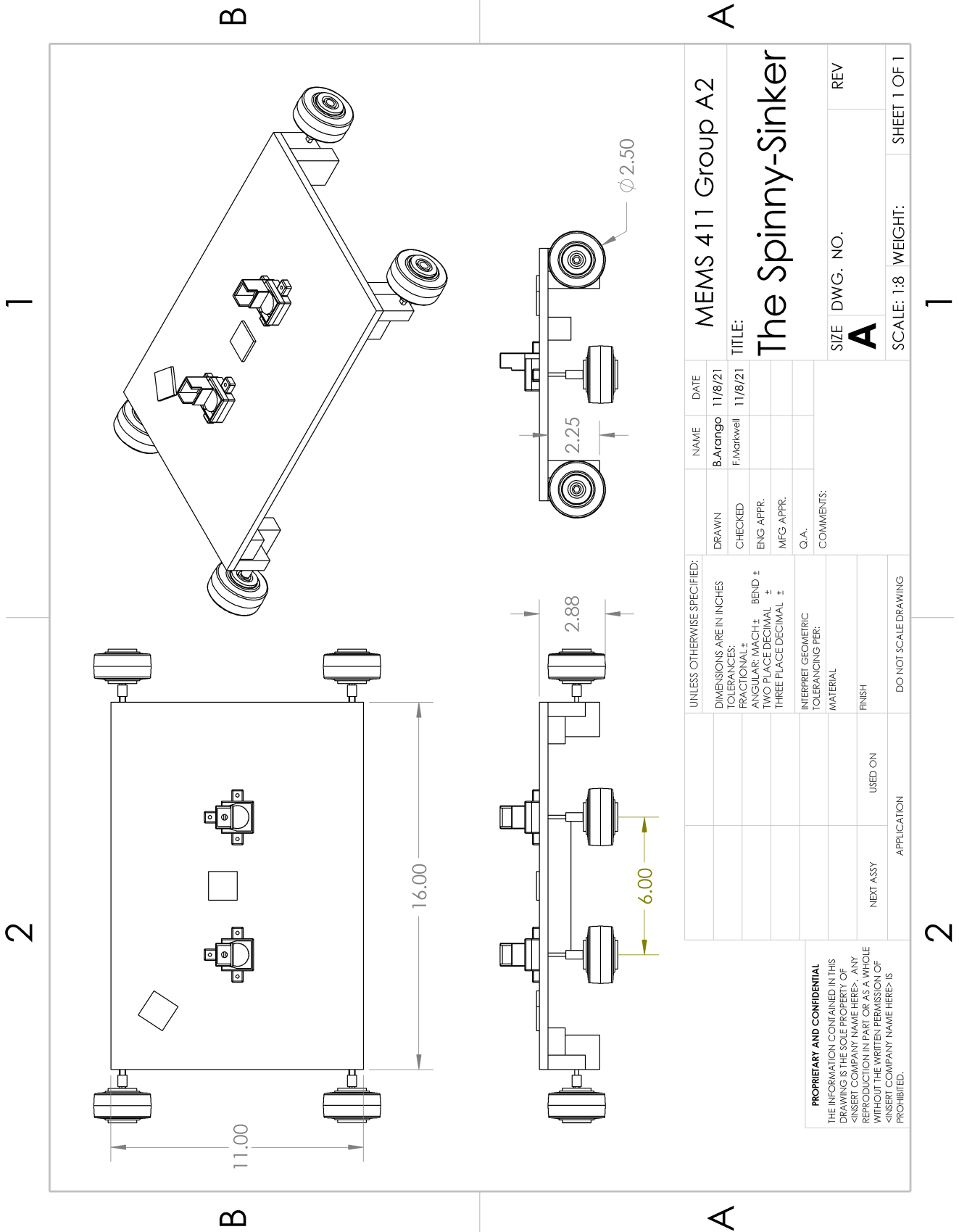

Figure 19: Velocity of an independent wheel based on surface and angular velocity

5 Concept Embodiment

5.1 Initial Embodiment



MEMS 411 Group A2		NAME	DATE	MEMS 411 Group A2	
DRAWN	B. Arango	11/8/21	TITLE:		
CHECKED	F. Markwell	11/8/21	The Spinnny-Sinker		
ENG. APPR.			SIZE	DWG. NO.	REV
MFG. APPR.			A		
Q.A.			SCALE: 1:8	WEIGHT:	SHEET 1 OF 1
UNLESS OTHERWISE SPECIFIED:		COMMENTS:			
DIMENSIONS ARE IN INCHES		INTERPRET GEOMETRIC TOLERANCING PER:			
TOLERANCES:		MATERIAL			
FRACTIONAL: ±		FINISH			
ANGULAR: MACH ± BEND ±		NEXT ASSY		USED ON	
TWO PLACE DECIMAL ±		APPLICATION			
THREE PLACE DECIMAL ±		DO NOT SCALE DRAWING			
<p>PROPRIETARY AND CONFIDENTIAL THE INFORMATION CONTAINED IN THIS DRAWING IS THE SOLE PROPERTY OF <INSERT COMPANY NAME HERE>. ANY REPRODUCTION IN PART OR AS A WHOLE WITHOUT THE WRITTEN PERMISSION OF <INSERT COMPANY NAME HERE> IS PROHIBITED.</p>					

23
Figure 20: Assembled projected views with overall dimensions

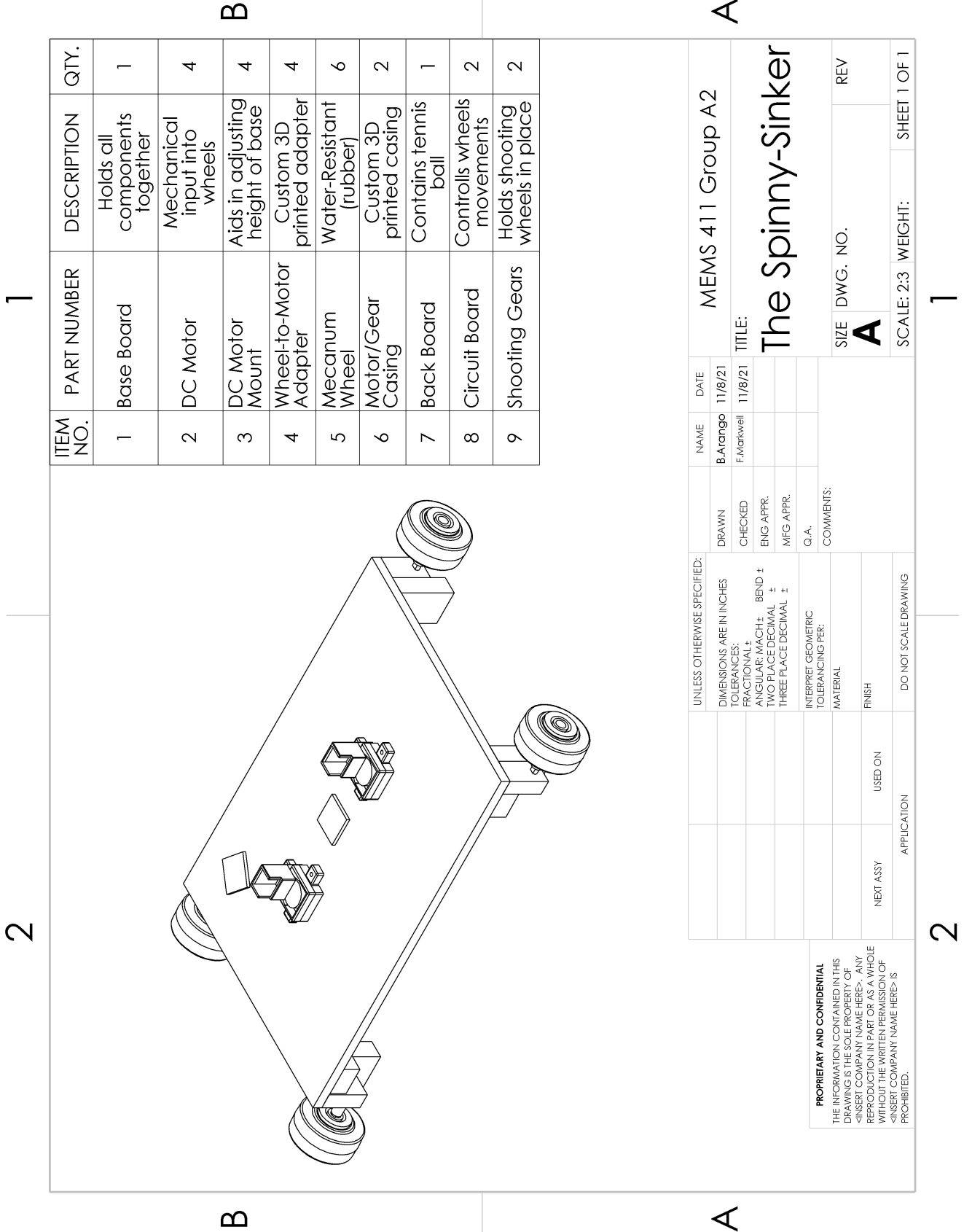
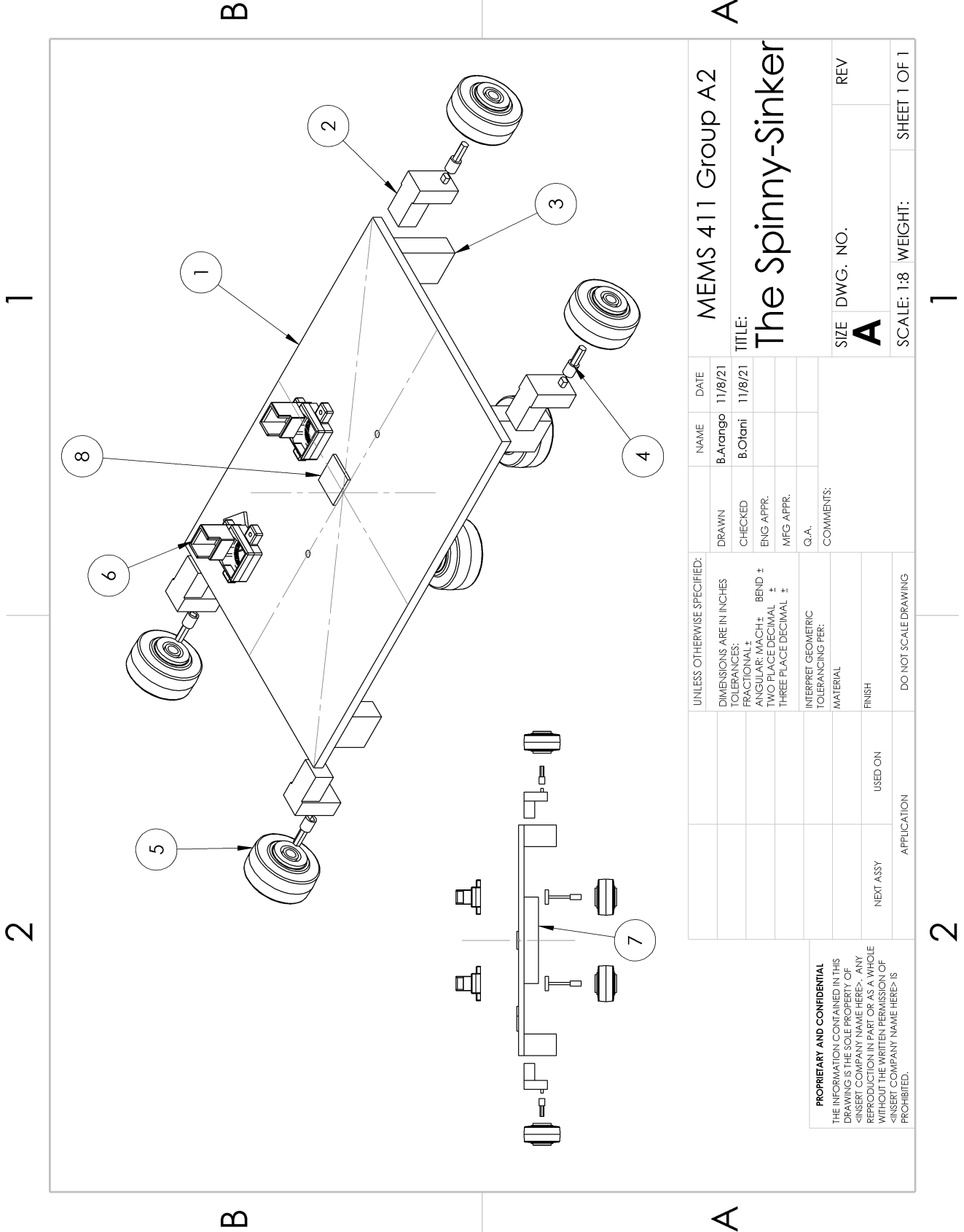

Figure 21: Assembled isometric view with bill of materials (BOM)



MEMS 411 Group A2		NAME	B.Arango	DATE	11/8/21
TITLE: The Spinnny-Sinker		DRAWN	B.Otani	CHECKED	11/8/21
SIZE		ENG APPR.		MFG APPR.	
DWG. NO.		Q.A.	COMMENTS:		
REV		INTERPRET GEOMETRIC TOLERANCING PER:			
SCALE: 1:8		MATERIAL			
WEIGHT:		FINISH			
SHEET 1 OF 1		NEXT ASSY		USED ON	
		APPLICATION		DO NOT SCALE DRAWING	

PROPRIETARY AND CONFIDENTIAL
 THE INFORMATION CONTAINED IN THIS DRAWING IS THE SOLE PROPERTY OF <INSERT COMPANY NAME HERE>. ANY REPRODUCTION IN PART OR AS A WHOLE WITHOUT THE WRITTEN PERMISSION OF <INSERT COMPANY NAME HERE> IS PROHIBITED.

Figure 22: Exploded view with callout to BOM

Three quantitative performance goals were decided and agreed upon by the groups working on the ASME Soccer Robot project. The objective of the initial prototype was to meet these goals and come up with a plan, through laid out steps, for the goals that weren't achievable.

The first goal is for the vehicle to drive along the outside edge of the playing field with a captured ball in 17 seconds or less. This goal targets the maneuverability and speed of our RC. Our vehicle was not able to complete this goal because of the limited speed produced by the geared motors. The plan to eventually meet this performance goal with the final prototype will be to either upgrade the motors we are currently using for the driving wheels or use gear ratios to make the wheels rotate faster than they do currently.

The second goal is to make half (5/10) shots from the midfield line, starting from the sideline with a tennis ball placed on the center spot. This performance goal tests strength and effectiveness of the shooting mechanism that was designed for capturing and releasing the ball during game play. This goal was not met because our shooting mechanism was still unstable and wasn't positioned in the correct way on our initial prototype base board to effectively get traction on the tennis ball to shoot it forward at a quick velocity. This is going to be improved with the redesign of some 3D printed parts and positioning the shooting mechanism wheels more effectively to induce a better grip on the ball when ready to shoot.

The third and final goal is to successfully capture a ball within 2 seconds of approaching it 8 out of 10 times. This goal was achieved with flying colors. The capture/shooting mechanism that we created is inspired by a ball launcher (for footballs or tennis balls), where the ball is placed between two vertically oriented wheels spinning in opposite directions. This mechanism was able to capture the ball every time that we tried, so we have exceeded the goal's threshold of 8 out of 10 times.

5.2 Proofs-of-Concept

The Proof-of-Concept testing and prototypes influenced our decisions for the initial and final prototypes heavily. Our first Proof-of-Concept prototype was a ball-shooting mechanism that consisted of two wheels on posts spaced so that a tennis ball could fit in between the wheels with some friction. This prototype allowed our team to visualize the idea of using two spinning wheels for our ball capture and ball shooting mechanism. The mechanism would be able to capture the ball by rotating in one direction, and eject the ball by spinning in the opposite direction. We chose to follow through with this idea for our prototype and it paid off quite well. It is a unique design, and a little more challenging, which made it a very fun and interesting problem to tackle.

The second Proof-of-Concept design created was a potential idea for a turning mechanism to help with driving. The idea of this prototype was to create an apparatus that could turn the front wheels like a standard automobile on the road today. We ended up deciding that there were too many moving parts, and since our purchased remote controlled car came with Mecanum wheels (a name brand of omni-direction wheels), we decided to use the driving mechanism improvements that Mecanum wheels provide, removing the need to rotate the wheels laterally. All wheels are able to stay straight, and because of the rollers along the wheel and the coordination of the wheels rotations (not always all rotating the same direction), side-to-side movements and rotations of the entire vehicle are achievable. This prototype ultimately influenced our decision to use Mecanum wheels.

5.3 Design Changes

The selected concept from Section 4 was Lana, a cone-shaped robot with two central motorized wheels and four support wheels that are not motorized. The shooting mechanism that Lana has consists of a spring-loaded plate and would rely on momentum of the movement of the entire vehicle to effectively capture the tennis ball for dribbling and shooting. The initial prototype is quite different from Lana, or "the bottle," in terms of design. The body shape and overall driving mechanism of the initial prototype is more similar to the ROV-inator, with the traditional 4-wheel placement, but features omni-directional wheels to eliminate the need for a separate turning mechanism. This method of driving allows for easier rotation of the entire body of the vehicle. The shooting mechanism is also different on the initial prototype in comparison to Lana. Lana has a spring-loaded plate, where the initial prototype has a ball-launcher esc. mechanism that features two vertically-oriented wheels spinning in opposite directions was tested and successful during our Proof-of-Concept prototypes, thus the spring loaded plate was not pursued. The overall body shape is a variable feature; the shape is a flat board for our initial prototype and was a cone shape for Lana to improve stability with just two motorized wheels in the center of the vehicle, which would be utilized for translational and rotational movement around the field of play.

6 Design Refinement

6.1 Model-Based Design Decisions

The first model design decision was to ensure we were inputting enough power into our device. The driving motors of the soccer robot were from Pololu, an online electronics and robotics shop. The website provided details on our specific motors, including the no-load stall torque, and RPM based on input voltage. (Stall torque or start torque is the minimum amount of force you can apply to the motor shaft and not have it rotate.) For our 7.2 Volt battery, the stall torque is approximately 0.549 N-m, and the no-load rotations per minute is about 90.8.

$$Power(W) = \frac{2\pi}{60}(RPM)(T) = \frac{2\pi}{60}(90.8\frac{rev}{min})(0.549N * m) = (9.5\frac{rad}{s})(0.549N * m) = 5.22W$$

From this calculation, we know the motor requires at least 5.22 W to rotate the unloaded motor shaft. Our shaft will be loaded, therefore this value will increase slightly, as the motor requires more current if loaded. Up to this point, we have had no issues with our motors stalling. Overall, this calculation is useful to better understand what is happening at our motors.

The second model decision/calculation was to check the speed of our current prototype. Note, this prototype is not our initial prototype, but an updated one. A prototype goal is to drive the car around the soccer field perimeter in 17 seconds. To calculate the distance our prototype drives in 17 seconds, we recorded a slow-motion video of our prototype and counted the number of wheel rotations in about 3 seconds. Surprisingly, we counted 3 rotations in 3 seconds, therefore our car drives 1 rev/sec. Using the wheel radius of 1.5 inches, we calculated the linear speed and then the distance our car drives in 17 seconds.

$$Speed = (r)(\omega) = (1.5in) * (1\frac{rev}{s} * 2\pi\frac{rad}{rev}) = 9.4\frac{in}{s}$$

$$Distance = (9.4 \frac{in}{s})(17s) = 160in = 13.33ft$$

13.33 ft is not the perimeter of the field, but it is significantly faster than our initial prototype. The boost in speed is due to increasing the battery from 3 V to 7.2 V. This was also calculated based on a prototype and not our final robot. The final robot's dimensions will be 10 x 14 as opposed to 11 x 16. The top will be made of acrylic that is thinner and lighter than this prototype's wood. Overall, we expect our final robot to be faster and cover more distance in 17 seconds.

The third model is a calculation of the reaction forces at wheels, based on the weight of the shooting mechanism. The figure below contains the work of this problem, including a free-body diagram. In Fig. 23, the wheels are modeled as pins and the shooting mechanism is approximately 3 lb. The result is that the reaction at each pin is 1/2 the weight applied. Obviously, this is a model and our car has 4 wheels, but the load will be distributed nearly equally across the 4 wheels (since our shooting mechanism is at the center of our board). This reminds us the importance of minimizing the weight on the board when possible.

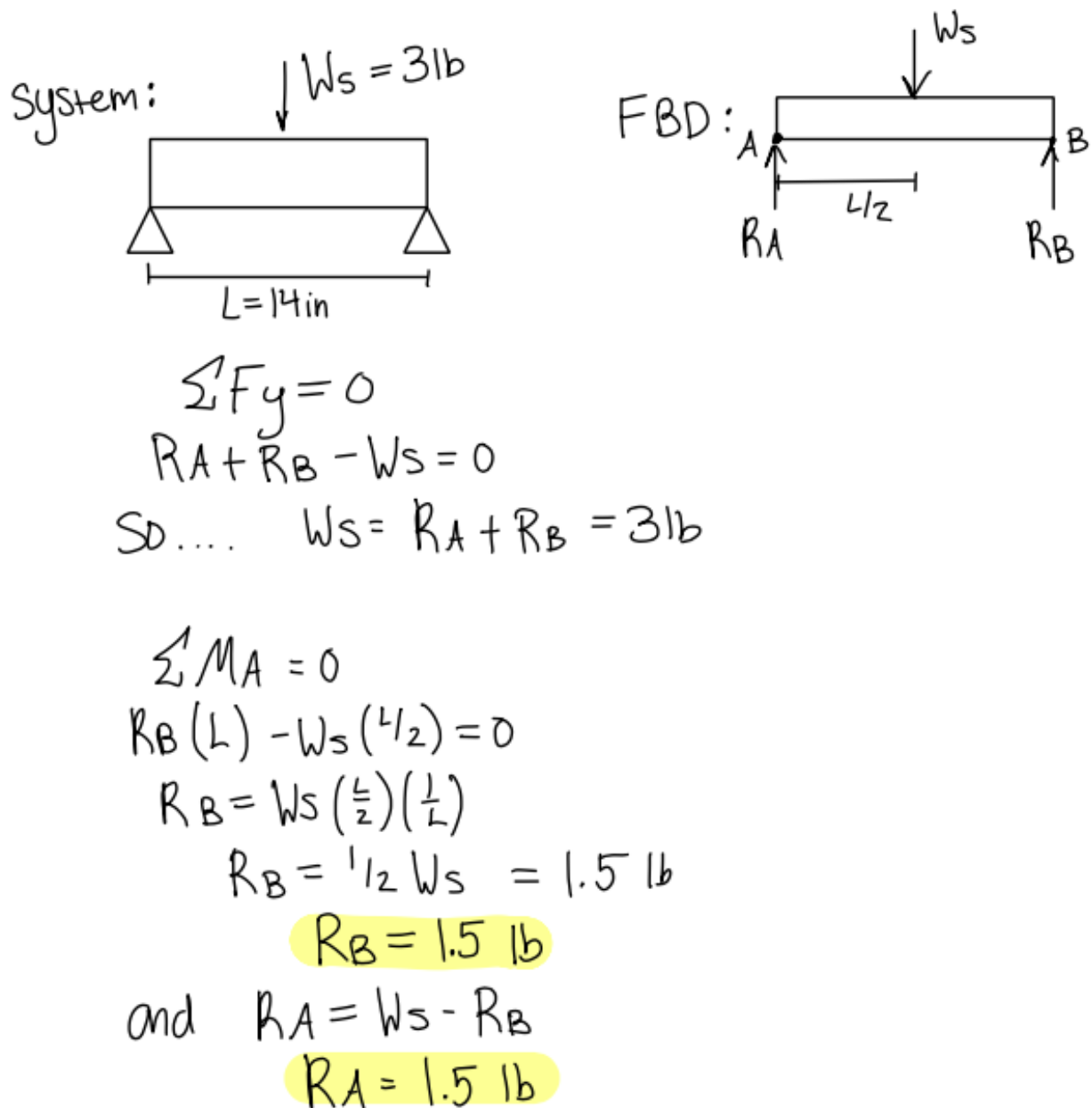

Figure 23: A calculation of the reaction forces at the wheels of our soccer robot.

6.2 Design for Safety

Below is the potential risks that were identified to possibly hinder the performance of our ROV. A heat map was made of the risks in relation to the severity and probability of each, which is shown in Fig. 24.

6.2.1 Risk #1: Overvoltage to Wheel Motors

Description: The motors being used for the wheels in our mechanism are rated for voltages up to 6 volts. Because of our use of a 7.2 volt battery, this introduces a small risk of overvoltage in the motor. This would cause the motors to stop working due to fried circuitry and/or the speed

of the gears being pushed past their limits, revealing the possibility of a electrical or mechanical problem.

Severity: Catastrophic

Probability: It is unlikely that this would occur due to more in depth research into the motors being used. Although the motors work best at 6 volts for maintaining durability and producing desired results, they have been tested with voltages up to 12 volts and have been shown to withstand this voltage.

Mitigating Steps: The only step that can be taken to reduce a risk such as this one is to obtain a 6 volt battery to be used instead of our current 7.2 volt battery.

6.2.2 Risk #2: Vibrational Disturbance

Description: The shooting mechanism causes vibrations throughout the ROV due to the high speeds and lack of precise restrictions on the wheels being used to shoot the tennis balls. This can cause nuts on the fastening bolts on the motor casing to come undone, resulting in unwanted movement in stationary parts.

Severity: Critical

Probability: This risk can occur occasionally, as the wheels in the shooting mechanism will be spinning almost continuously.

Mitigating Steps: We have purchased and are using nuts that are designed to prevent loosening from vibrations.

6.2.3 Risk #3: Grinding Gears in Shooting Mechanism

Description: The gear on the motor that connects to the gear on the wheel of the shooting mechanism is positioned in such a way that the motor can fit into the casing while the wheel gear is inside the casing. Because of this, there is a slight gap between the two which occasionally causes slippage.

Severity: Marginal

Probability: This is an occasional risk, since it works as expected majority of the time.

Mitigating Steps: Reducing movement of the casing with nuts and bolts to reduce possibility of slippage.

6.2.4 Risk #4: Wires on Motors coming Apart

Description: The wires that connect to the shooting mechanisms motors are not soldered well and tend to break off easily, blocking off the power transferred to the motors and ceasing the wheels functions.

Severity: Critical

Probability: This is a seldom occurrence, as there is no force being applied to the wires when mounted properly.

Mitigating Steps: The soldering of the motors will be redone, as well as hot glue being used to hold the wires in place and reduce possibility of breaking.

6.2.5 Risk #5: Radio Signal Interference between Remote Controls

Description: There are two remote controls being used; one for the shooting mechanism and one for the movement of the robot. Since the two controllers are identical, they send out signals on the same frequency and cause interference with each other.

Severity: Negligible

Probability: They are very unlikely to interfere too drastically with each other, as the only occurrences we have experienced of this was when we turned both on at the same time and they swapped the devices they were controlling.

Mitigating Steps: No mitigation steps are needed.

		Probability that something will go wrong				
Category		Frequent Likely to occur immediately or in a short period of time; expected to occur frequently	Likely Quite likely to occur in time	Occasional May occur in time	Seldom Not likely to occur but possible	Unlikely Unlikely to occur
Severity of risk	Catastrophic					Overvoltage to Wheel Motors
	Critical			Vibrational Disturbance	Wires on Motors coming Apart	
	Marginal			Grinding Gears in Shooting Mechanism		
	Negligible hazard presents a minimal threat to safety, health, and well-being of participants; trivial					Radio Signal Interference between Remote Controls

Figure 24: Heat Map of Risks Listed

The risk that we have prioritized, in relation to the heat map made, is the vibrational disturbance caused by the spinning of the shooting mechanisms wheels. This is due to its common occurrence and potential to cause damage to the other parts of the robot. This was fixed by using nuts and bolts to hold down the motor casings to the base, restricting as much free motion as we could. In addition to this, we used bolts that were slightly larger than the 0.15 in-diameter holes so that we could drill them in, adding threading to the inside of the holes and allowing them to hold the casings more firm. This reduced the risk immensely, allowing for the wheels to spin with minimal shaking.

6.3 Design for Manufacturing

The number of components excluding threaded fasteners is approximately 44 parts. The number of threaded fasteners we added to our design is approximately 36. Our robot is symmetric in 4 quadrants, and each driving wheel has 6 parts, and 4 excess fasteners. Each part of our shooting mechanism has 4 pieces and 5 screws. There are also two batteries and two circuit boards that sit on the top of our robot.

Theoretically necessary components (TNCs) include:

- **The spacer between our platform and driving wheels.** Our driving platform must be a minimum height to allow the ball to be fed into our shooting mechanism. Given that our wheels have a set diameter, we required a spacing block between the motors and the platform to allow proper elevation. This was achieved through 4 separate wood blocks that are glued onto the platform. To decrease the number of parts, we could cut and glue two separate long spacers on each side of the robot, as seen in Fig. 25. This would minimize the number of parts while introducing a small amount of extra weight, but would also help ensure the spacer sticks on the car by maximizing the surface area of the adhesive. In doing this, the risk of the spacers detaching from the platform would be reduced.

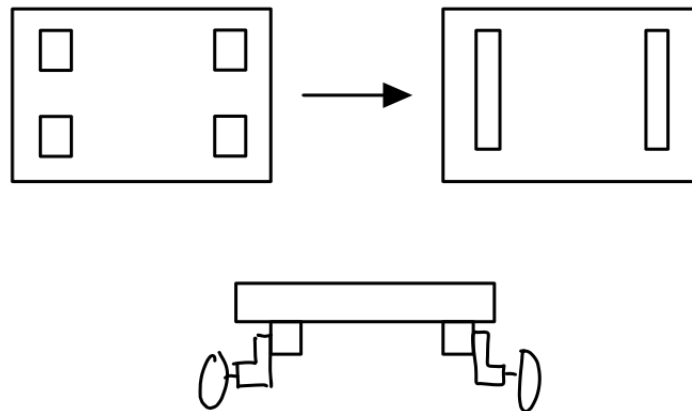

Figure 25: Drawings of design update from four individual spacers to two long spacers, bottom view and front view

- **The shooting wheel and coupler must be separate components attached using a small screw.** These are two TNCs since the shape of the hole of the provided wheel doesn't match the shaft of the motor; therefore an adapter is needed. Currently, we screw the wheel to the inserted part of the coupler. If we 3D printed a piece that is a tighter fit into the wheels, and glued that onto the current spinning shaft, we would no longer need the screw.
- **The two separate batteries on separate circuit boards.** Hypothetically speaking, if we had more electrical experience (which we are not expected to have, so it is okay), we could have used one battery and one circuit instead of two separate ones. This would decrease the number of parts sitting on our circuit board. Though, we are not worried about draining our batteries since we have two separate ones. The use of one circuit board would have allowed us to use one remote as opposed to two.

- **The metal mount which mounts our motors to spacers.** Right now it is necessary because we need to secure the motors to the board. Hypothetically, we could have 3D printed a piece that simultaneously holds the motors still and attaches them to our platform. This would certainly negate the mount between the motor and spacer and the screws used, which were tiny and quite annoying. If designed properly, it could also negate the need of a spacer, and place the motor shaft at an appropriate height. There are a few ways we could design this 3D printed part. It would either attach to the side of the board, like a clip, or be screwed into the platform. The motor would be fitted or attached to the house to ensure no movement occurs. Figure 29 shows one design idea for this 3D printed part. Here, the part is fastened to the platform, and the motor is fit into a slot.

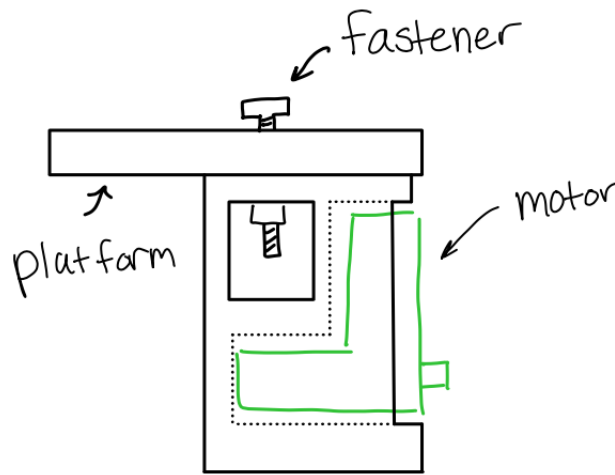

Figure 26: Possible 3D printed part for updated spacer

6.4 Design for Usability

Our design features no color-coded components or flashing lights to indicate anything while in operation. Thus, individuals with a **vision** impairment such as red-green color blindness will have no trouble operating the ROV. All color-coded wiring and electrical connections are made during construction and is not required by the user. The only interaction the user will have with the electrical components are connecting the battery and turning the circuit boards and remote controllers on. Both of these tasks are achievable by physical indicators like raised “off” and “on” lettering on the controllers.

Those with a **hearing** impairment will not face any disadvantages while using this ROV design. There are no speakers for auditory indicators. Sounds are not crucial to game play during the competition, so we believe that those with a hearing impairment will be able to operate the ROV with no significant disadvantage.

Users operating the ROV that have **physical** impairments like arthritis or muscle weakness may find the controls a little difficult. Fine motor skills will prove handy when controlling the robot because of its use of two remote controllers with analog sticks. Each remote controller has two analog sticks, one that is constrained in the horizontal direction, and the other constrained in the vertical direction. The ability to physically change directions of the shooting wheels’ rotation or driving around the robot quickly and vary the speeds at which the wheels spin will depend on the

user's physical inputs to the analog sticks.

Individuals with a **control** impairment such as distraction, intoxication, or medication side effects, would affect the usability of our robot, but not by much. The robot does not forego its functionality because of poor control or movement. The user inputs the control for the robot to move or shoot a ball, thus if the user isn't paying attention or has a slower-than-average reaction time, the robot awaits an input from the user. Now, if the user's conditions were severe, like intoxication that inhibits judging distances between the car and the wall of the playing field, the user could end up damaging the robot by ramming it full speed into a rigid object like the opposing robot or the wall. An increase in cushion around the edges and securing all parts to the robot's base would be ways to mitigate catastrophic outcomes in the case of a collision.

7 Final Prototype

7.1 Overview

The final prototype of the ROV made for the ASME Soccer Robot Competition is shown in Figures 27, 28, and 29. It incorporates the wheels from a disassembled RC (Mecanum Wheels) into the design of both the shooting mechanism and directional systems, in which the final ROV was capable of achieving two of the three design goals; the ones for capturing a tennis ball and shooting it accurately. The speed of the vehicle can be improved through integration of new circuit boards that can handle more wattage without burning up, as well as more powerful motors than the ones used.

7.2 Documentation

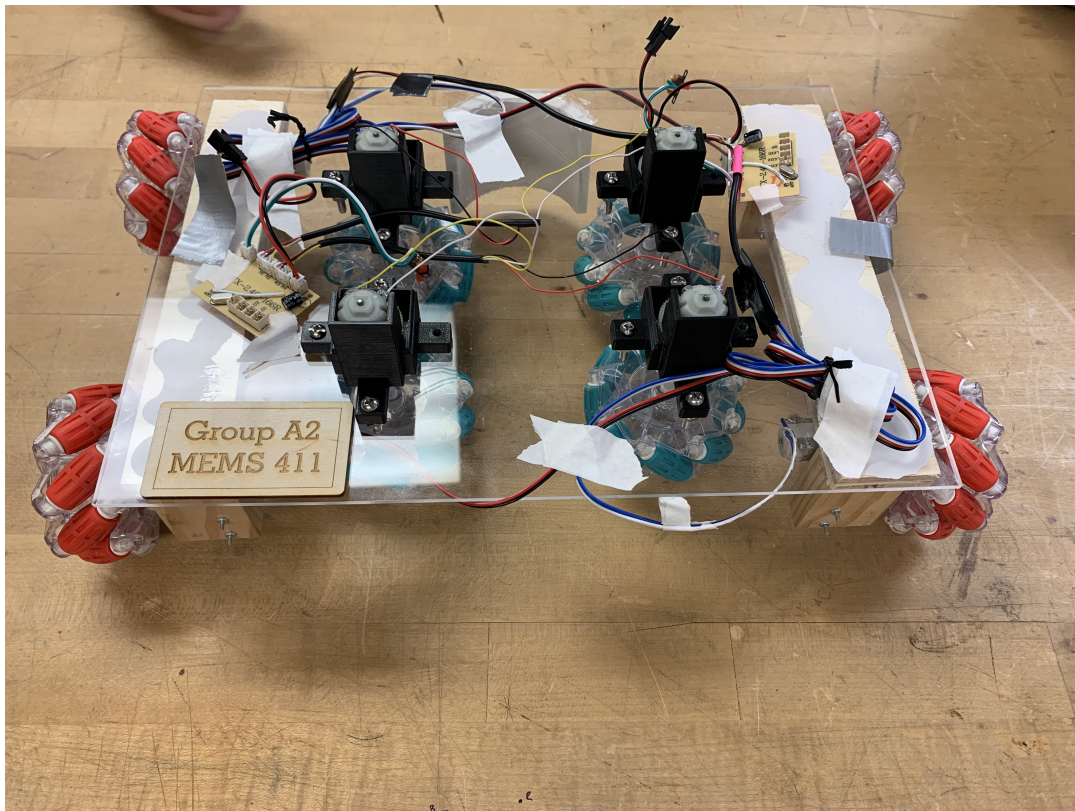

Figure 27: Overhead view of final ROV

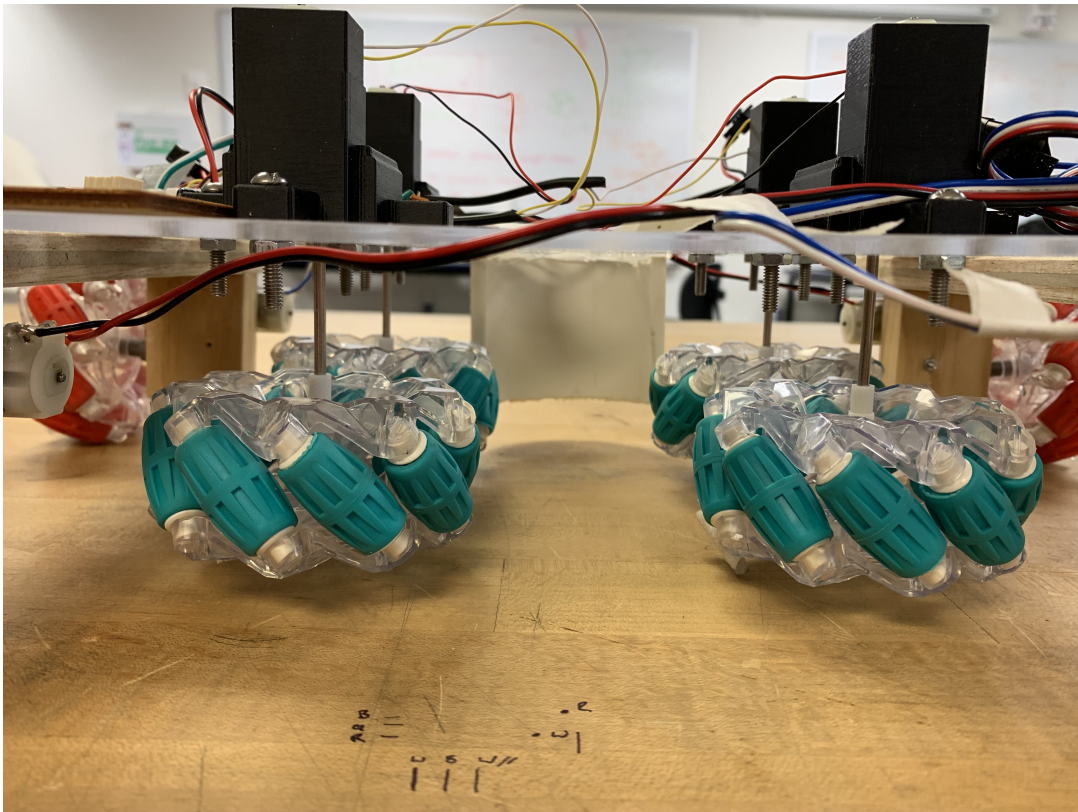

Figure 28: Shooting Mechanism and Backboard

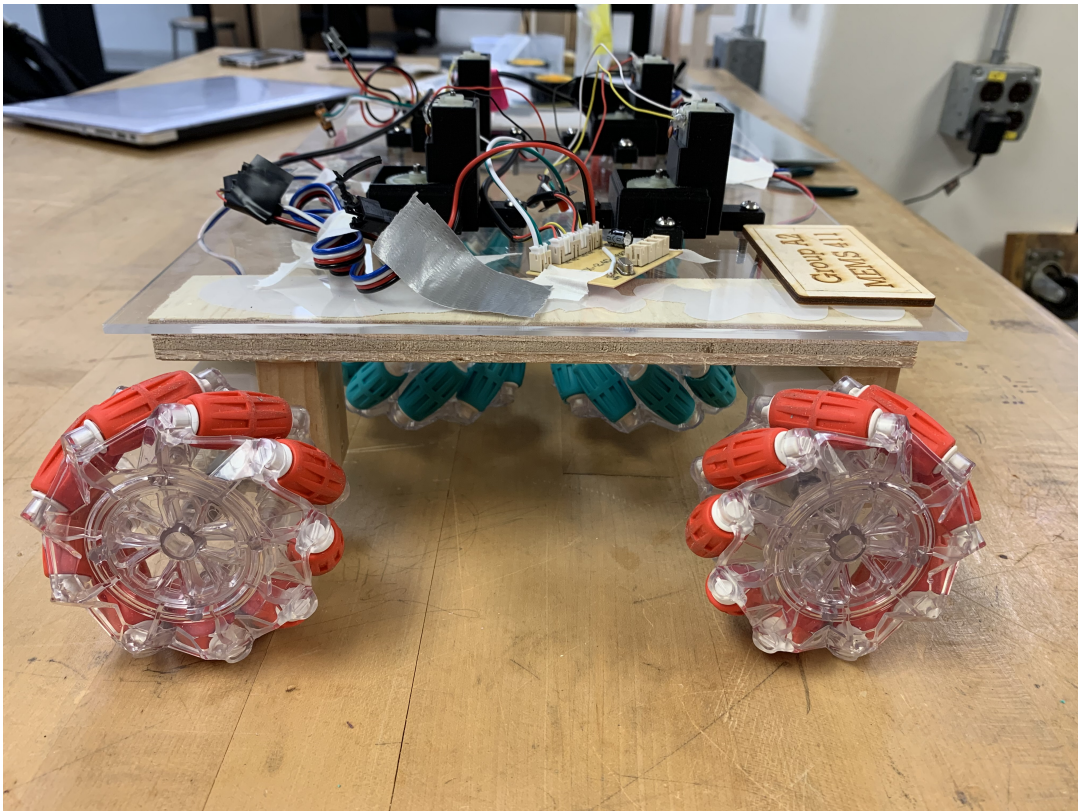

Figure 29: Side view of final ROV

Bibliography

- [1] Alexander Perzylo. *RoboCup German Open 2010*. URL: <http://roboearth.ethz.ch/robocup-german-open-2010/index.html>.
- [2] 97%Robotics. *97%Robotics - Soccer Open League - Qualifikationswettbewerb in Sankt Augustin für den RoboCup Junior*. URL: <https://www.youtube.com/watch?v=vinEOHeYD6w>.
- [3] iRobot. *iRobot® Roomba® i3 (3150)*. 2021. URL: <https://store.irobot.com/default/roomba-vacuuming-robot-vacuum-irobot-roomba-i3-3150/i315020.html>.
- [4] J Blumrich. *Omnidirectional wheel*. URL: <https://patents.google.com/patent/US3789947A/en>.
- [5] Fumiaki Tsurukawa. *Soccer and fighting robot, and driving and operating device of the robot*. URL: <https://patents.google.com/patent/US7463001B2/en>.