

Washington University in St. Louis

Washington University Open Scholarship

Mechanical Engineering and Materials Science
Independent Study

Mechanical Engineering & Materials Science

12-23-2021

Improved Pill Splitter: An Analysis of 3&4-Point Bending to Split Pills

Isaac Sasser

Washington University in St. Louis

Andrew Brown

Washington University in St. Louis

Minju Lee

Washington University in St. Louis

Follow this and additional works at: <https://openscholarship.wustl.edu/mems500>

Recommended Citation

Sasser, Isaac; Brown, Andrew; and Lee, Minju, "Improved Pill Splitter: An Analysis of 3&4-Point Bending to Split Pills" (2021). *Mechanical Engineering and Materials Science Independent Study*. 167.
<https://openscholarship.wustl.edu/mems500/167>

This Final Report is brought to you for free and open access by the Mechanical Engineering & Materials Science at Washington University Open Scholarship. It has been accepted for inclusion in Mechanical Engineering and Materials Science Independent Study by an authorized administrator of Washington University Open Scholarship. For more information, please contact digital@wumail.wustl.edu.



Washington University in St. Louis

JAMES MCKELVEY SCHOOL OF ENGINEERING

FL21 E37 MEMS 500 Independent Study
Advisor: Dr. Jackson Potter

**Improved Pill Splitter:
An Analysis of 3&4-Point Bending to Split Pills**

There is a niche in the pill splitting industry for a more efficient pill splitter. To fill this niche we explore various applications of 3-Point and 4-Point bending to pill splitting. All designs are 3D printed. Due to the elastic nature of PLA plastic, the reality that 3-Point bending may cause pills to fail in compression (as revealed by FEM analysis), and the difficulty in managing volume constraints in a 3-Point bending design, 4-Point bending is considered as a viable option for pill splitting. However, after testing and analysis, the 4-Point bending prototypes generated were able to break pills, but not split in half, which is unacceptable.

SASSER, Isaac
BROWN, Andrew
LEE, Min Ju

Contents

List of Figures	2
List of Tables	2
1 Introduction	3
2 Problem Understanding	6
2.1 Existing Devices	6
2.2 Patents	9
2.3 Codes & Standards	11
2.4 User Needs	11
2.5 Design Metrics	14
3 Material Behavior	14
3.1 Brittle Fracture	14
3.2 Pill Material Properties	15
3.3 3-point vs 4-point bending	15
4 Concept Generation	15
4.1 Function Tree	16
4.2 Morph Chart	17
5 Prototyping	18
5.1 Initial Prototypes	18
5.2 Isaac's Initial Bending Prototypes	18
5.3 Dr. Potter's and Andrew's Flexible Prototypes	20
5.4 Isaac's Bending Prototypes	24
6 FEM Analysis of Pill 3-Point Bending	26
6.1 Cookie Configuration	26
6.2 Reverse Cookie Configuration	28
7 Final Prototype	31
7.1 FEM 4-Point Bending	31
8 Conclusion	33
Bibliography	35
Appendix A Hand Calculations	37
Appendix B 4-Point Final Prototype Testing	39

List of Figures

1	Pill split by pressing it against the shaft of the screwdriver.	3
2	Basic force diagram to represent pill under 3-point bending.	4
3	Prototype development cycle.	5
4	Multiple Pill Splitter (Source: Amazon.com)	6
5	Equadose Pill Cutter: Top View	7
6	Equadose Pill Cutter: 3-D View	7
7	Ezy Dose Pill Crusher and Grinder	8
8	Pill Splitter for people with arthritis	8
9	Exploded view of pill splitter for people with arthritis	9
10	Patent image for US 10,245,215 B2.	10
11	Patent Images multiple pill cutter	11
12	Failure patterns of granite cylinders of height to diameter ratios between 0.2 and 0.6 [2].	15
13	Finalized morphological chart	17
14	Dr. Potter’s initial prototypes after use.	18
15	Version 6 and 7 of Isaac’s prototypes.	19
16	Diagram of two options of force application to accomplish 3-point bending.	20
17	Our first compliant methods functioned much the same way hands do when the are used to break a cookie in half [8]	21
18	Dr. Potter’s first compliant prototype.	22
19	The trajectory of the cutters right hand splitting arm plotted against the profile of the upper right quadrant of an ibuprofen pill.	23
20	Andrew’s cookie break style compliant splitter.	24
21	CAD model of Reverse Cookie method device.	25
22	3D printed prototypes of Versions 8-10 of for the Reverse Cookie Method device.	25
23	von Mises Stress results of pill under 3-point bending in cookie breaking configuration.	27
24	1st Principle Stress results of pill under 3-point bending in cookie breaking configuration.	28
25	von Mises Stress results of pill under 3-point bending in reverse cookie breaking configuration.	29
26	1st Principle Stress results of pill under 3-point bending in reverse cookie breaking configuration.	30
27	Dr. Potter’s final 4pt bending prototype.	31
28	von Mises Stress for the 4pt bending load condition.	32
29	1st Principle Stress for the 4pt bending load condition.	33
30	Shows crack propogation in the pill.	39
31	Shows crack propogation in the pill.	40
32	Pill testing results from the additional prototypes.	40

List of Tables

1	Interpreted Customer Needs	13
2	Target Specifications	14

1 Introduction

In a continuation of the project by the Fast Pill Cutter group from Washington University in St. Louis's Mechanical Engineering Design Project Class of Spring 2021, we seek to design and construct a pill splitter that splits pills using 3-point bending.

We were initially inspired to utilize 3-point bending from our experience with splitting pills by pressing them against a cylindrical object such as a screwdriver (Fig. 1). As can be seen, this technique tends to result in a single crack that propagates in a fairly straight line through the center of the pill in the direction normal the face in contact with the cylinder. This is the crack behavior needed for a successful pill splitter.



Figure 1: Pill split by pressing it against the shaft of the screwdriver.

We hypothesize that a pill under 3-point bending as represented in Fig. 2 will fail in a similar manner to the pill pressed against a small cylinder.

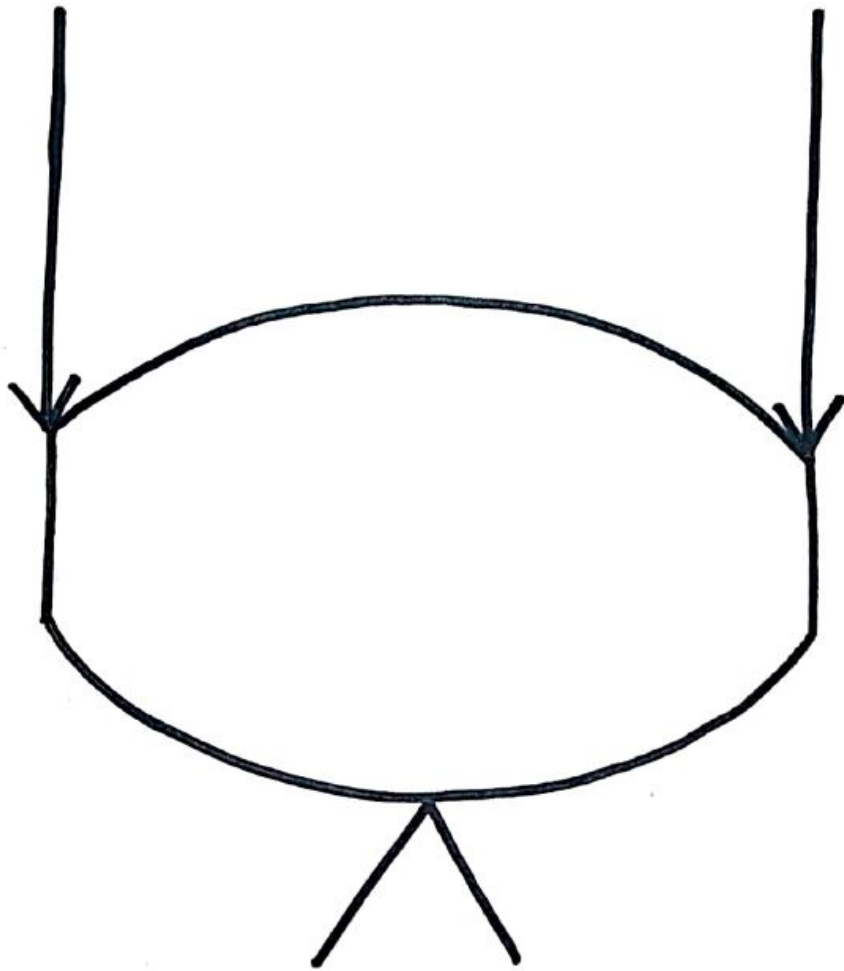

Figure 2: Basic force diagram to represent pill under 3-point bending.

We also seek to test this theory using 3D printed prototypes. This is because 3-D printing allows for fast, efficient, and accurate prototyping. Additionally, the end goal of this project is to create a design that can be scaled split pills of many different sizes. By creating an easily adjustable CAD model that can be 3D printed, users will be able to rapidly customize the design to cut pills of many different sizes. This mode of design and assembly also allows for simple distribution should it be desired.

Prototype development is expected to follow the pattern shown in Fig. 3.

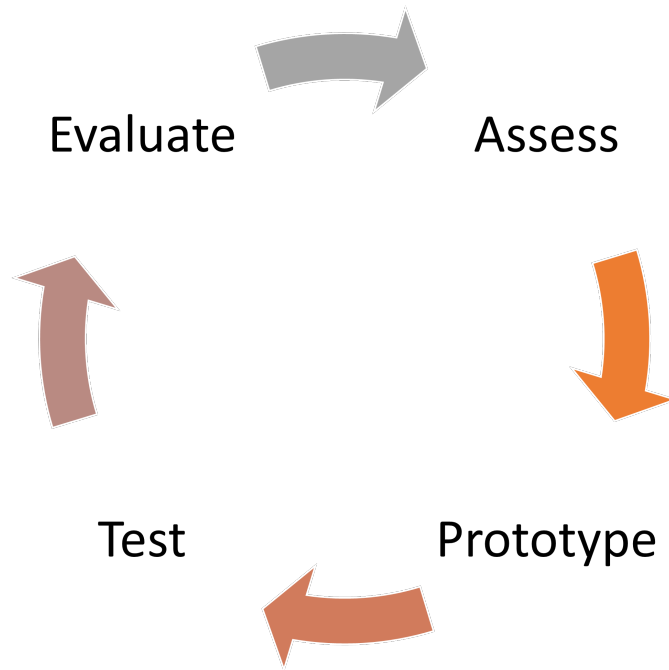

Figure 3: Prototype development cycle.

In the assessment phase of the cycle, the team will work to understand existing devices as well as perform background research to develop models to guide the design of the prototypes. We will use any new knowledge we gain to design the next prototype. Prototype design will be done using hand sketches as well as parametric modeling in SolidWorks. Once the design is complete, it will be printed and tested. The results of the testing phase will drive the next assessment phase and the process will repeat. This process will allow the team to rapidly design and iterate on the prototypes while still using a model based design approach.

2 Problem Understanding

The background research performed by the Spring of 2021 group is now presented to set the stage for our development of both 3-point bending and 4-point bending pill splitters [1].

2.1 Existing Devices

The three top pill cutters on the market appear to be the Multiple Pill Splitter, The Equadose Pill Splitter, and Ezy Dose Pill Crusher and Grinder. The Multiple Pill Splitter is our closest competitor as it is the only splitter that is capable of cutting more than one pill at once.

2.1.1 Existing Device #1: Multiple Pill Splitter



Figure 4: Multiple Pill Splitter (Source: Amazon.com)

Link: <http://www.pillcut.com/>

Description: The Multiple Pill Splitter is a manually operated splitter capable of splitting between five and fifteen pills, depending on pill size. The device functions by aligning pills in a row between two spring loaded arms used to hold the pills in place. The user then closes the cap over the line of pills, cutting the pills in half with a stainless steel knife. This product is one of the more expensive options, but it also comes with a lifetime warranty, making it an attractive option for buyers.

2.1.2 Existing Device #2: The Equadose Pill Splitter



Figure 5: Equadose Pill Cutter: Top View



Figure 6: Equadose Pill Cutter: 3-D View

Link: <https://www.amazon.com/dp/B00U84Q80K?tag=medconsumersus-20>

Description: The Equadose Pill Splitter both cuts and stores pills using its rotating cutting wedges. The pill is placed between the wedges and cut; the pill halves can then be stored in the cylindrical chambers by sliding the plastic cover over the top of the device. The Equadose Pill Cutter is made primarily of high-quality metal parts, making it durable and reliable. One major drawback is that the cutter can only cut and store one pill at a time, making mass cutting impractical. The device is also rather costly at \$30.

2.1.3 Existing Device #3: Ezy Dose Pill Crusher and Grinder



Figure 7: Ezy Dose Pill Crusher and Grinder

Link : <https://www.amazon.com/dp/B000E0ZHF0?tag=medconsumersus-20>

Description: This product contains multiple components necessary for medication proportion control. Pill scorer, pill crusher, organizer, and pill drinking cup are integrated into one single device. This device is helpful for anyone with the need to consume medication on daily basis. This device can also hold up to 4 aspirin-sized pills for traveling people.

2.1.4 Multiple pill or tablet splitter By 3-point Bending

This splitter was not discussed by the Fast Pill Splitter Group but is noted here because it makes use of 3-point bending to split the pills, which we also intend to do.

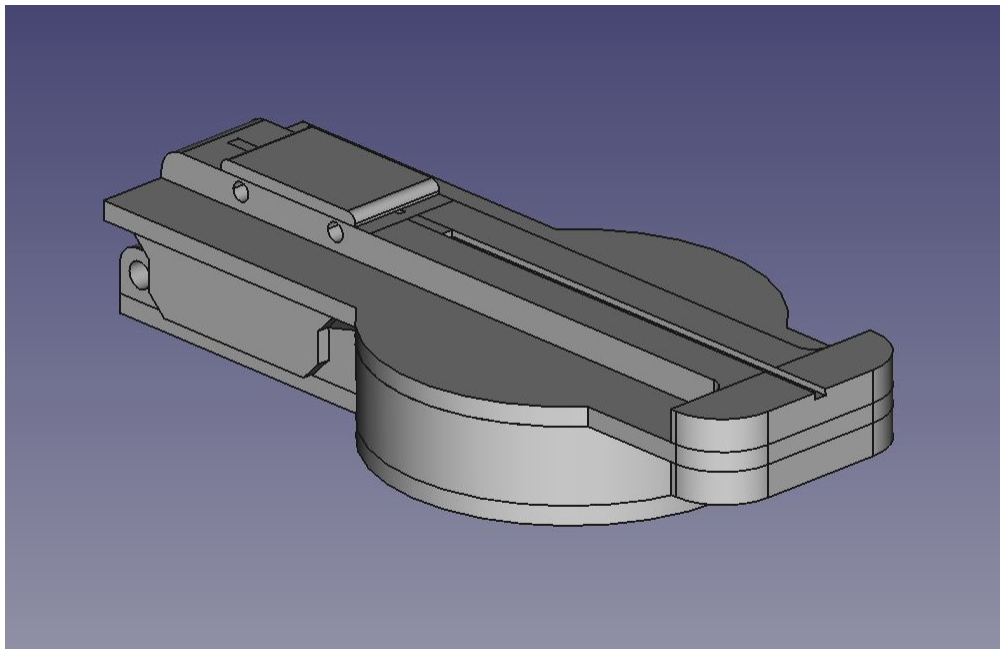

Figure 8: Pill Splitter for people with arthritis



upper-part.stl



bottom-part.stl

Figure 9: Exploded view of pill splitter for people with arthritis

Link : <https://www.myminifactory.com/object/3d-print-pill-splitter-77608>

Description: This product contains multiple components necessary to split generic solid pills. Pill scorer, pill splitter, placer, and pill dispensing cup are integrated into one single device. It also available to the public for 3D printing. Also, this design was highlighted in an article showing how 3D printing adaptive aids generally save those with arthritis more than 94% compared to purchasing them. Therefore, this model may reveal some important lessons when designing for usability.

2.2 Patents

2.2.1 Pill Cutting and Storage Device (US 10,245,215 B2)

The patent describes the design of a manual pill splitter and storage device. The splitter consists of a rotating shell housing two hollow chambers, with a splitting wedge separating them. The two halves of the shell rotate separately. The device works by separating the halves, aligning a pill with the cutting wedge, and bringing the halves together to split the pill. Each half of the split pill will then rest in one of the hollow chambers. The pills can be stored long-term by closing a rotating plastic cover, sealing off the hollow chambers.

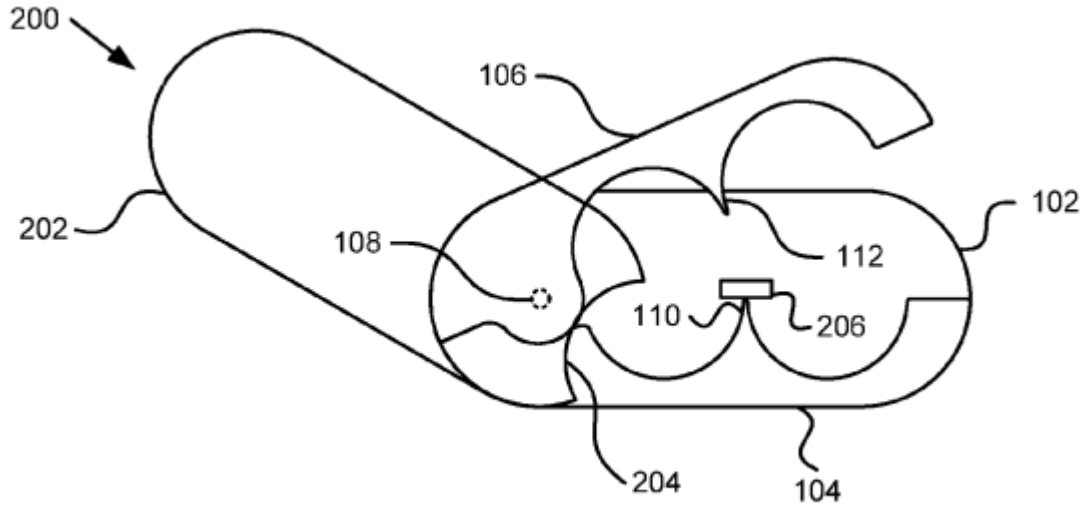

Figure 10: Patent image for US 10,245,215 B2.

2.2.2 Multiple pill or tablet splitter (US 9,827,165 B1)

The patent describes the design of a manual pill splitter that can handle multiple pills. The cutter is made up of two primary sections. The top section (#50 Fig 11), which contains the blade, and the bottom section (#11 Fig 11), which holds the pills in place to be cut. The guide rails on the bottom (#30 in Fig 11) can be adjusted to handle multiple shapes and sizes of pills. The pill splitter can handle up to 9 pills at a time. The splitter works by centering and securing the pills under the blade. Then the top is closed on the pills splitting all the pills at once.

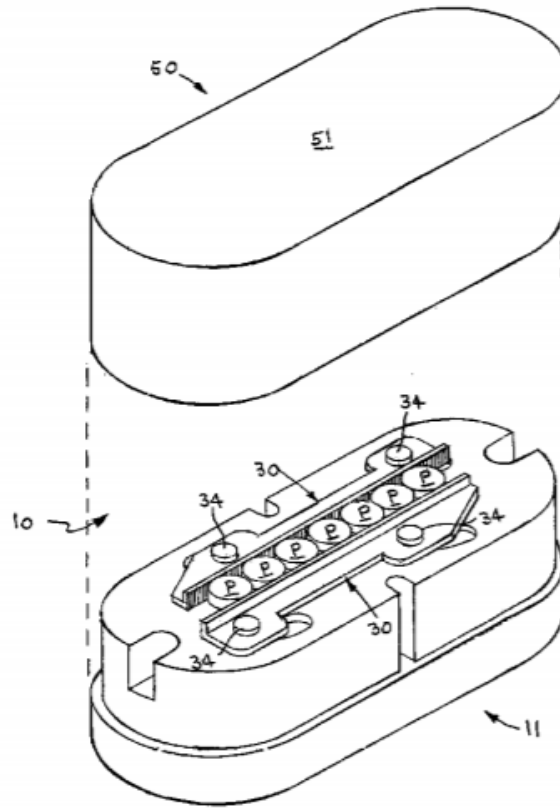

Figure 11: Patent Images multiple pill cutter

2.3 Codes & Standards

2.3.1 Food and Drugs - Allowable Adhesives (21CFR175.105)

This is a Code of Federal Regulations laid out by the Food and Drug Administration (FDA) on the requirements for adhesives in food contact devices. This code specifies when and for what adhesives can be used in food contact products. We will decide whether or not adhesives are a viable tool for our use depending on the price and functionality of compliant adhesives.

2.3.2 Sanitizing - Equipment Cleaning and Maintenance (21 CFR § 211.67)

This Code of Federal Regulations comes from the Food and Drug Administration and applies specifically to the handling of pharmaceuticals. Within this code are instructions that provide the process by which utilities that process pharmaceuticals ought to be cleaned. It also outlines proper cleaning schedules. Knowledge will teach us how important it is that our design be easily cleanable. It will also provide insight into designing a splitter that will be easy to clean.

2.4 User Needs

We interviewed two potential customers for this project: Anna Sasser from Laynes Pharmacy in Eden, NC, and Kyle Copeland from St. Luke's Pharmacy. Important insights from each interview are listed below, along with interpreted user needs and metrics derived from them.

2.4.1 Customer Interview

Interviewee: Anna Sasser (Laynes Pharmacy)

Location: Remote (Phone). Laynes Pharmacy is located in Eden, NC.

Date: February 2nd, 2021

Interview Notes:

How many pills do you split?

- I usually split 30-60 pills in a sitting, once a week. Rarely, I have to split 180 pills in a sitting.

How long does the splitting take?

- 30 pills can be split in 2-3 minutes. 180 pills can take 15 minutes to half an hour.

What pill shapes do you usually split?

- The pills are usually round, sometimes oval. Round pills are easier to split than oval ones.

How much does your current splitter cost?

- \$6-8.

How often does a pill split poorly?

- The cutter can crush pills sometimes. I'd estimate 4-5 out of every 30-60 pills have to be trashed.

How often does the splitter need to be cleaned?

- The splitter needs cleaning between different drugs because allergies are a concern. Also, crumbs build up and the cut won't be clean if too many crumbs are in the way. I have to clear out pill crumbs every 2-3 cuts.

How long do your current pill splitters last?

- They aren't very durable. We have 6 or 7 cutters and we switch one out every 2-3 months. When the blade gets dull, we just throw the whole cutter away.

Are there any safety concerns with the current splitter? Is it possible to hurt yourself while using it?

- You might have to hold the pill while lowering the top and you could cut yourself. It happens pretty rarely though, probably once every 3-5 months.

Interviewee: Kyle Copeland (St. Luke's Inpatient Pharmacy)

Location: Remote (Telephone). St. Luke's Inpatient Pharmacy is located in Chesterfield, MO.

Date: February 5nd, 2021

Interview Notes:

How often do you have to split pills?

- Normally two major batches a week and then sporadically. In major batches, 200 to 400 pills are split.

How long does the splitting take?

- It takes between 1.5 and 2 hours to split a major batch of pills.

What pill shapes do you usually split?

- Normally scored circular tablets are split. Elliptical tables are split as well, but this is more rare. The most common pill (Metoprolol) is between 0.5 and 0.75 cm in diameter.

What fractions do you normally split pills into?

- Pills are generally split in half and are split into quarters only 1 to 2% of the time. Pills have a tolerance of $\pm 3\%$, so eyeballing is sufficient to confirm that the pill has been split into equal halves.

How much does your current splitter cost?

- \$1.97.

How often does a pill split poorly?

- The older spiltter consistently crushes half of the tablet. The new crushes only 1 in 100 when the operator is careful.

How often does the splitter need to be cleaned?

- The blade gathers particulates after the first 50 splits and needs to be wiped after 100 splits or it will crush tablets. The splitter must be wiped down with alcohol between different types of pills. Splitters that are used to split medicines classified as hazardous by NIOSH only used to split one type of hazardous medicine and are never used to split anything else.

How long do your current pill splitters last?

- A splitter lasts about 10,000 tablets. The blades would be very difficult to replace, so the entire splitter is replaced instead. These comments apply to a cutter made by Apothecary Products.

Are there any safety concerns with the current splitter? Is it possible to hurt yourself while using it?

- It is very rare to cut one’s self with this splitter.

2.4.2 Interpreted User Needs

After carefully considering the costumers’ comments we compiled the following table to represent the costumer needs that the pill splitter (PC) must fulfill. The we ranked the needs between most important, 5, and least important, 2.

Table 1: Interpreted Customer Needs

Need Number	Need	Importance
1	The PC splitter is efficient at splitting pills.	5
2	The PC is affordable.	4
3	The PC can split pills cleanly.	4
4	The PC can split pills precisely.	5
5	The PC is safe to use.	4
6	The PC need to be easy to clean/sanitize.	4
7	The PC can queue up a large quantity of pills at once.	2
8	The PC has a long life span.	4
9	The PC meets food safety requirements.	5
10	The PC is easy to operate.	3
11	The PC can split different-shaped pills.	1
12	The PC can split different-sized pills.	4

The biggest customer need is for the ability to split pills much faster than allowed by the pill splitters currently on the market. Therefore, needs pertaining to the effectiveness of the splitter, such as efficiency and preciseness were ranked as most important. The customers mostly split round pills, so the ability to split multiple pill shapes was considered the least important need.

2.5 Design Metrics

These metrics are based on the quantification of our customer’s needs. For a well-designed and novel automatic pill splitter, some metrics of our product need to be equivalent or surpass the market-available devices. The ideal and acceptable threshold of these metrics will also depend on the importance of the correspondent customer’s need.

Table 2: Target Specifications

Metric Number	Associated Needs	Metric	Units	Acceptable	Ideal
1	1,6,7	Splitting rate	pills/hour	< 200	< 400
2	2,8	Cost/Operational Life	\$/month	> \$x	> \$x
3	3	Number of Pills Crushed	fraction	> x/100	> x/100
4	4	Halves within the 3% tolerance	Boolean	Pass	Pass
5	5	Blades enclosed during operation	Boolean	Pass	Pass
6	9	Food safe (meets 21CFR175.105)	binary	Pass	Pass
7	10	Time to max splitting rate	Batches	3	2
8	11	Compatible pill shapes	list	Circular	Circular, Oval
9	12	Diameter of compatible pills	mm range	5-7.5	4-10

3 Material Behavior

The vast majority of pills that are split are brittle and disk shaped. Therefore, to aid our pill splitter design process we conducted a study on fracture of brittle materials in general, and also brittle materials shaped similarly to pills. We used Ibuprofen in the majority of our tests, so we investigated the material properties of Ibuprofen for use in our FEM simulations. We also performed a literature review on 3-point and 4-point bending to see how best to apply these techniques to pill splitting.

3.1 Brittle Fracture

In 2019 a study was conducted to predict failure of granite in mining tunnels [2]. 50 mm diameter cylinders of granite with varying height to diameter ratios were split under 3-point bending. Because the tested samples were both brittle and similarly shaped to our pills the study may lend insight to our pill splitting problem. It was found that a cylinder with a H/D ration near 0.5 failed in a straight line that split the cylinder evenly into two halves (Fig. 12). Our Ibuprofen pills, which are fairly representative in shape of most pills, have a H/D ratio of 0.51, lending confidence that our brittle pills will split in half under 3-point bending.

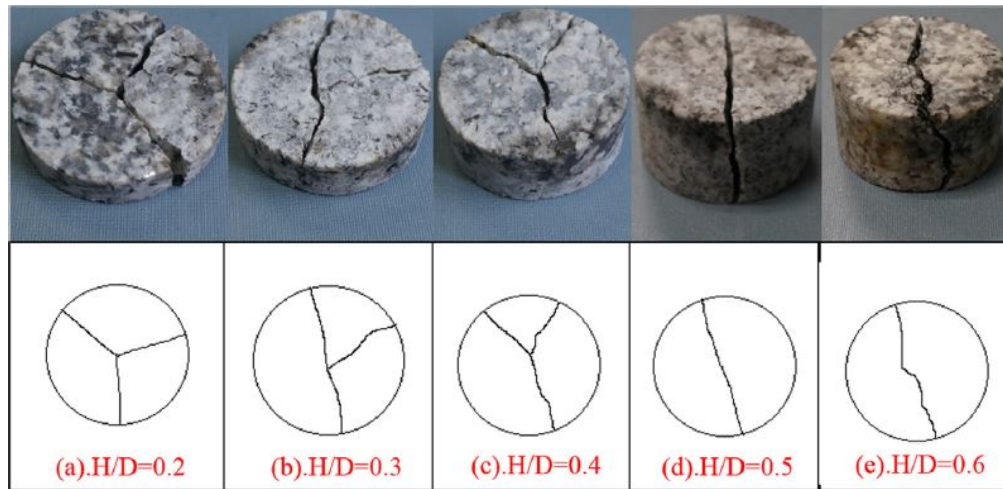

Figure 12: Failure patterns of granite cylinders of height to diameter ratios between 0.2 and 0.6 [2].

Another way to help ensure a uniform fracture pattern is to create a flaw on the pill surface opposite of the applied force. This should create a stress concentration that determines where the crack starts [3] and allows the crack to propagate in a straight line toward the point of the force application.

3.2 Pill Material Properties

For use in our SolidWorks FEM, we estimated Ibuprofen to have a modulus of elasticity of 3 GPA. This value came from a report experimenting with the change in material properties of Ibuprofen in relation to its porosity [4]. Additionally, following the lead of the Bristol-Myers Squibb Company and their work in determining the "tensile strength of shaped tablets," we assumed a Poisson's ratio of 0.3 because this produces reasonable displacements in comparison to real-life pill behavior [5].

3.3 3-point vs 4-point bending

There are two major bending mechanism that will be used in this study: 3-point vs 4-point bending. 3-point bending causes an object to experience the maximum stress at the material's mid point while 4-point bending causes an object to experience the maximum stress along an extended region [6]. 3-point bending mainly introduces a normal stress to a material while 4-point bending produces bending state over a significant area of an object. Therefore, 4-point bending has higher volume under stress compared to that of 3-point bending. Since, according to Weibull statistics, the bigger volume under stress is directly proportional to increased probability in creating longer crack or flaw, the 4-point bending is a more desirable mechanism for splitting an object with a mechanical load. Thus, both mechanisms should be tested to observe the differences in the pill splitter setting [7].

4 Concept Generation

4.1 Function Tree

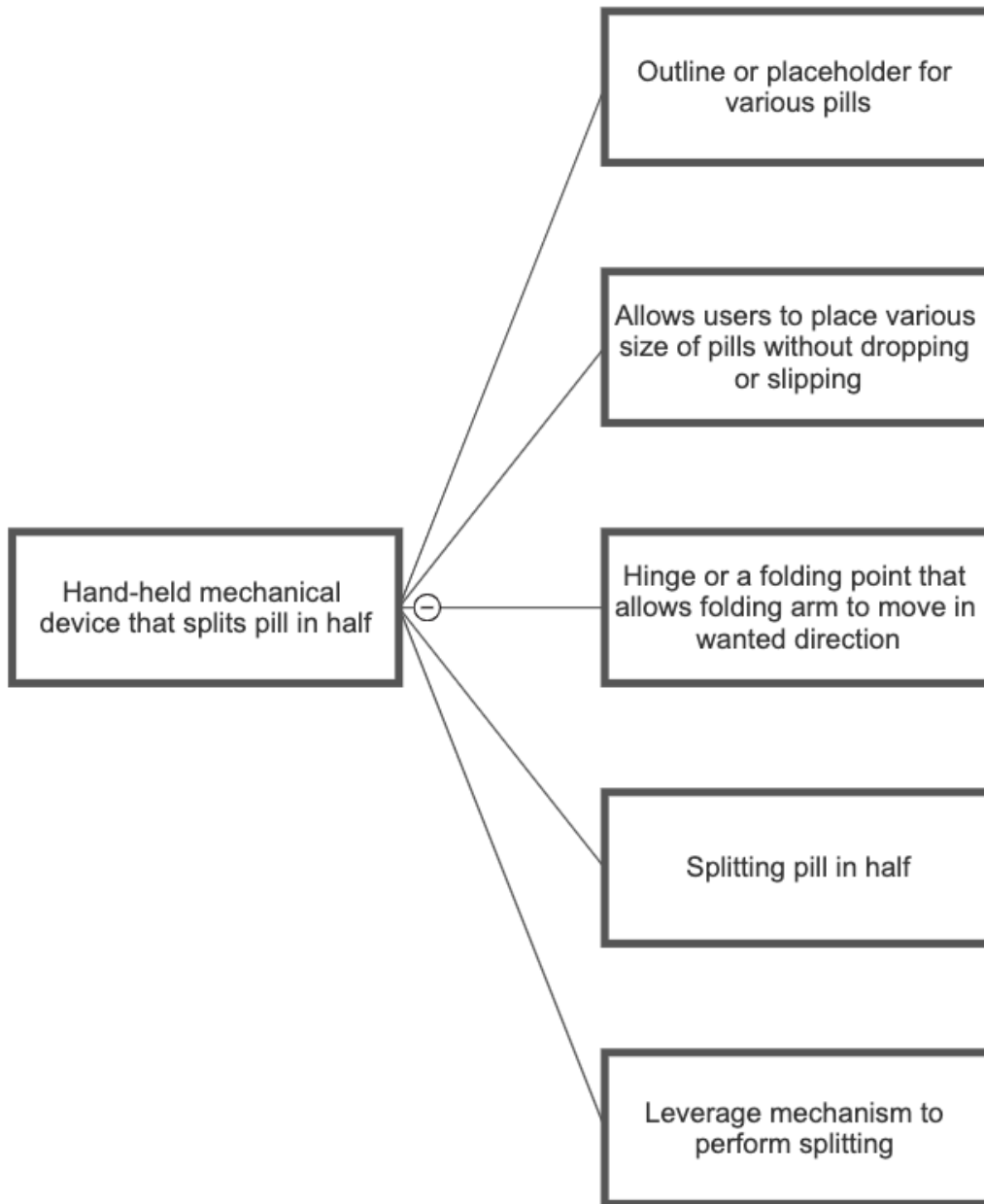

The function tree addresses our key requirements to split solid pills that are made of brittle material. Our device should provide a place for the user to place the pills that will keep the pills in place while being split. While performing pill splitting, the device should provide a mechanical advantage, allowing the user to use less force than actually required to split a pill.

4.2 Morph Chart









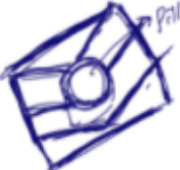

Functions			
Outline or placeholder for various pills	Placeholder for various sized pills 	Placeholder for various sized pills 	Placeholder for various sized pills 
Allows users to place various size of pills without dropping or slipping	Pill holder 	Pill holder 	Pill holder 
Hinge or a folding point that allows folding arm to move in wanted direction	Elastic folding point 	Folding arm 	Rotating arm 
Splitting pill in half	Compression based splitting 	Bending moment 	Three point bending 
Leverage mechanism to perform splitting	Leverage arms 	Leverage arms 	Leverage arms 

Figure 13: Finalized morphological chart

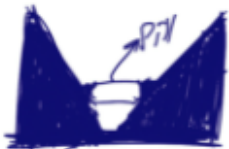
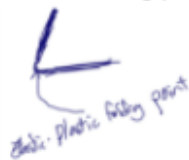
The morphological chart shows visualized mechanisms that meet our function tree requirement. All of our designs were determined assuming 3D printed semi-elastic material.

5 Prototyping

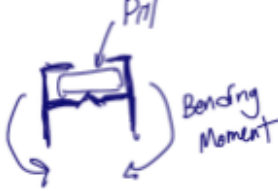
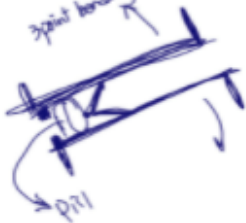
The prototypes in this section were developed according to Fig. 3. As each prototype was developed, 3D printed, and tested, the team documented and analyzed the results and issues of each prototype. After the initial prototypes, developed by Dr. Potter, the two different prototyping paths emerged. Dr. Potter continued to develop from his existing prototypes while the rest of the team looked into trying to 3D print the situation seen in Fig. 2.

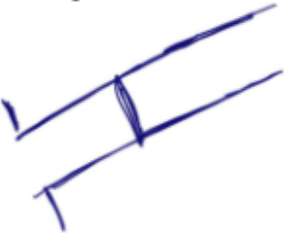
5.1 Initial Prototypes

To gain a baseline, Dr. Potter printed five initial concepts, all applying 3-point bending. versions 1 and 2 (Fig. 14) both spit the pills successfully, but were slow to use and offered no significant mechanical advantage to the user. Version 3 could not split the pills. Version 4 was exciting because it would allow us to break multiple pills at once and offered a mechanical advantage by allowing the user to apply a force with a moment arm to split the pills within the device. Unfortunately, the stiffener that allowed the structure to support itself also prohibited the user from applying an effective crushing force to the pills. Version 5 did not create a high enough load concentration for the pills to split cleanly. Instead, it crushed the pills, making it a non-viable option.

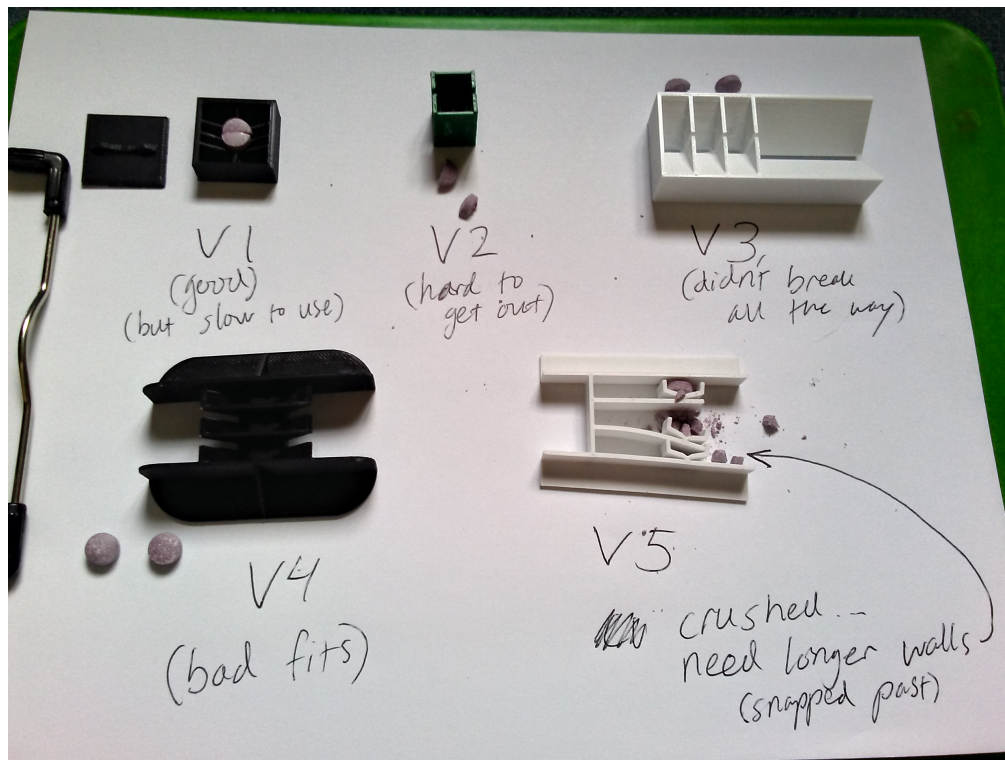

Figure 14: Dr. Potter's initial prototypes after use.

5.2 Isaac's Initial Bending Prototypes

Isaac's initial bending prototypes were designed to replicate the proof of concept tests done with the screwdriver. The goal was to design and print a device that could deliver a constant 3-point bending load to the pills. Additionally, from Dr. Potter's initial prototypes, the team learned that

a hard stop was necessary to avoid crushing the pills. Version 6 and 7 (Isaac's first prototypes) of the pill splitter prototypes are shown in Fig. 15.

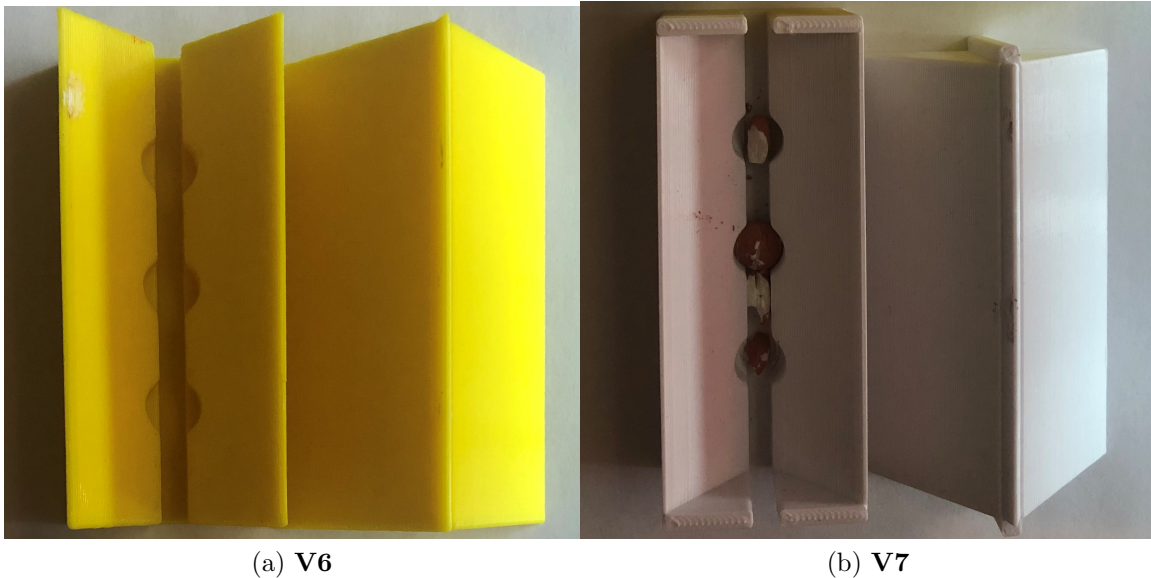

Figure 15: Version 6 and 7 of Isaac's prototypes.

5.2.1 Version 6 Results and Discussion

Version 6 of the pill splitter was intended to deliver a constant force to the pills which were fixed in the slots shown. Using the trough design, the splitter would stop after the pills were split and not crush the halves. In addition, the trough was intended to guide the splitter to the center of the pill each time.

There were several issues with version 6. First, the trough design could not both stop the device after splitting the pill and at the same time guide the splitter to the center of the pill. As a result, the device would stop in the appropriate location but it was challenging to center the splitting edge on the pills. Second, this design consistently crushed the pills. This was assumed to be caused by the amount of support at the bottom of the pills in the pill slots. In addition, it was slow to use and required a lot of force to crush the pills.

5.2.2 Version V7 Results and Discussion

In an attempt to address the issues mentioned above, version 7 included an external guide and slot to keep the splitter centered throughout the entire process. In addition, the support on the bottom of the pills was both decreased and angled such that it only contacted the pill at a single location. This was intended to attain more of the pure 3-point bending shown in Fig. 2.

While the guide effectively centered the splitting edge each time, this prototype also consistently crushed pills. Figure 15 shows that there did not appear to be room for the pills to break. This was evidenced by the fact that the pills would get stuck in the device after being crushed. This brought up interesting concerns about the conservation of volume and its role in splitting pills.

5.2.3 Volume Considerations

An important principle of pill splitting is that a properly split pill will exhibit conservation of volume, with the two halves of the split pill adding up to the volume of the intact pill. When splitting a pill over the cylindrical shaft of a screwdriver or using a razor blade, after initial fracture, there is nothing to prohibit the separated sides of the pill from diverging from their initial positions, allowing the cutting apparatus to occupy the space that, previously, was occupied by the fully intact pill. However, as demonstrated by versions 6 and 7, it is difficult to automate 3-point bending such that the split pill has the freedom to escape the cutting device.

To illustrate this point, consider the rightmost sketch in Fig. 16. The rigid supports prohibit the pill from escaping to the left or the right, but the cutting object must continue through the body of the pill forcing the pill to change volume, thereby crushing the pill.

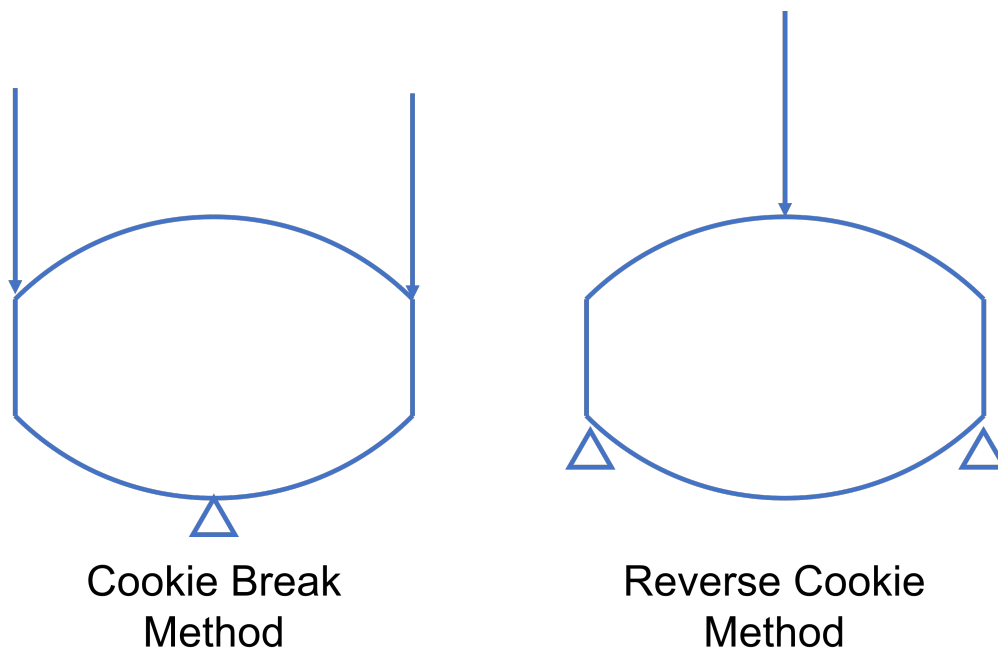

Figure 16: Diagram of two options of force application to accomplish 3-point bending.

5.3 Dr. Potter's and Andrew's Flexible Prototypes

With these volumetric considerations in mind, the next few prototypes attempted to split the pills according to the leftmost sketch of Fig. 16. Instead of a cutting point forcing itself through a pill constrained by peripheral supports, we employed a stationary center support and applied opposing forces that could displace with the pill as it began to crack. The splitter operated much as hands operate while breaking a cookie in half (Fig. 17).



Figure 17: Our first compliant methods functioned much the same way hands do when they are used to break a cookie in half [8]

Around this same time, the team began to investigate the application of compliant mechanisms to deliver a 3-Point bending load to the pills. In our context, compliant mechanisms are dynamic apparatuses that only undergo elastic deformation, allowing for very long lifespans [9]. By combining

the concept of compliant mechanism and our cookie splitting theory, Dr. Potter produced the prototype in Fig. 18.

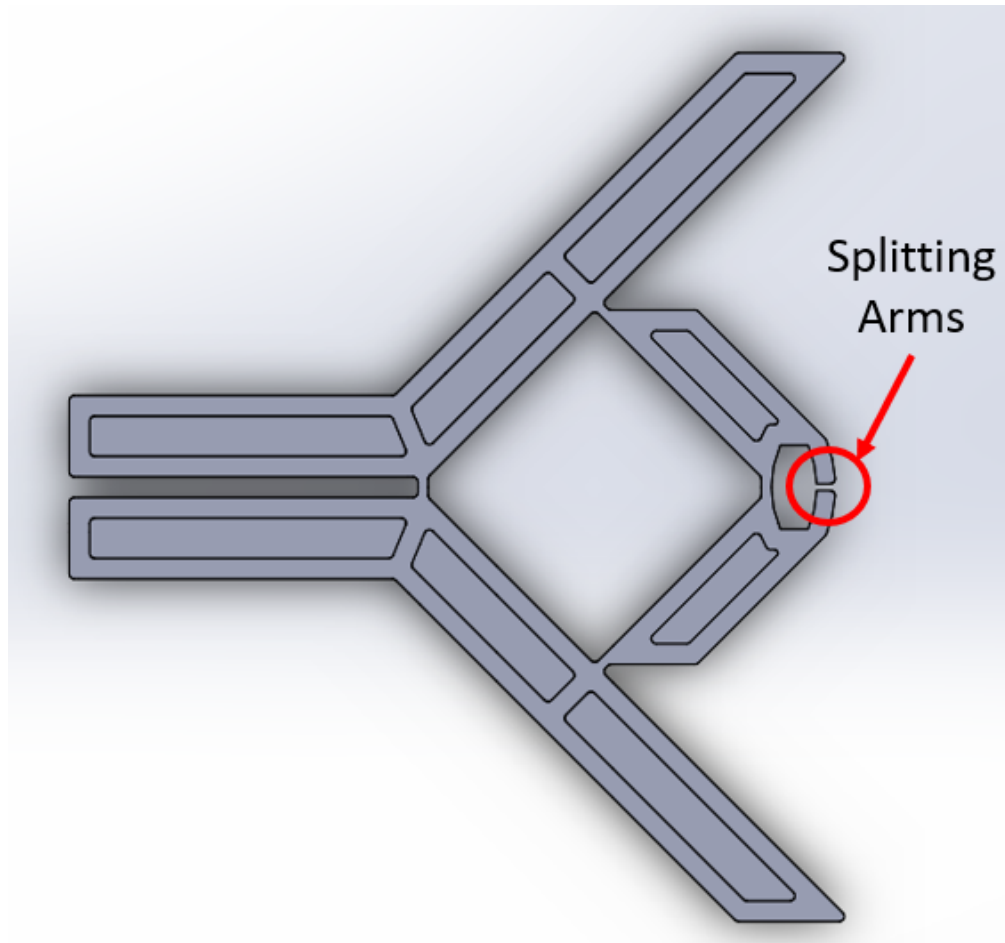

Figure 18: Dr. Potter's first compliant prototype.

Mathematically, there is no reason why this cutter should have failed. A mathematical model of the profile of the pill plotted against a model of the trajectory followed by the splitting arms reveals that the splitting arms intrude on the boundary of an un-split pill (Fig. 19) (See Appendix A for trajectory calculations). Therefore, if the pill splitter were perfectly rigid, the pill would be forced to crack in half as the pill splitter applied force to the pill. Unfortunately, PLA is not rigid. So, when the splitter applied force to the pill, the splitting arms bent, allowing the pill to escape the splitter before the arms applied enough force to cause the pill to split.

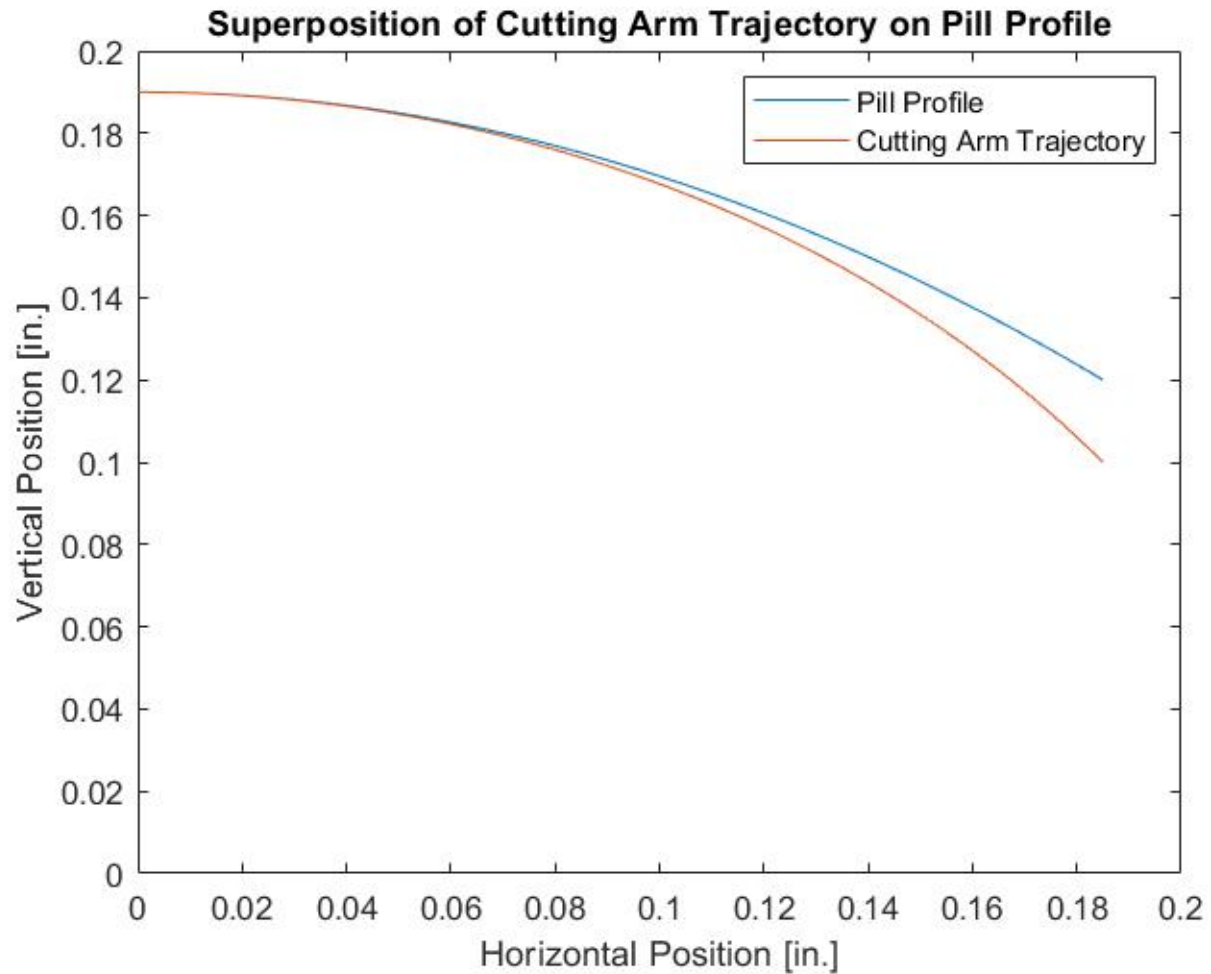

Figure 19: The trajectory of the cutters right hand splitting arm plotted against the profile of the upper right quadrant of an ibuprofen pill.

5.3.1 Compliant Prototype Version Results and Discussion

Because PLA has a relatively low modulus of elasticity, we suspected that Dr. Potter’s cookie-breaking design might be improved by decreasing the gap between the splitting arms of the cookie-cutter design. Theoretically, this would cause more overlap between the contour of the pill and the path followed by the breaking arms, applying enough force to break the pill before the cutting arms flexed enough to allow the pill to escape unbroken.

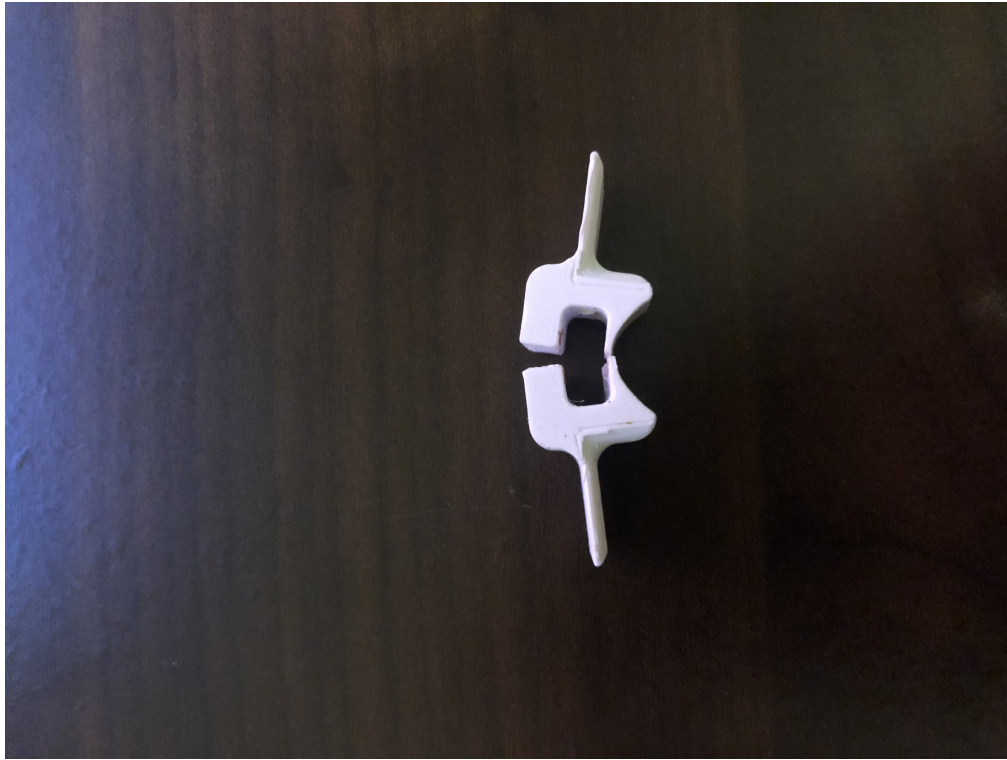

Figure 20: Andrew's cookie break style compliant splitter.

Unfortunately, decreasing the gap was insufficient to cause the pill to split. Additionally, the thin bridge connecting the right side and the left side of the splitter failed after relatively few cycles, suggesting that the dimensions of this design resulted in plastic deformation instead of the elastic deformation essential to compliant mechanisms.

5.4 Isaac's Bending Prototypes

The Reverse Cookie Method was another approach to the bending prototypes was attempted. This method was designed to amplify the force input using complaint mechanism to break the pill at a lower cost to the user.

5.4.1 Reverse Cookie Method Compliant Device

Figure 21 shows a CAD model of the compliant Reverse Cookie device. We were optimistic that this device would not have the same volumetric problems as previous devices because once cracked, the pill should be able to escape from the well it sat in. This was accomplished by attempting to have only vertical roller supports on the pill face instead of fixing the side as shown in Fig. 16.

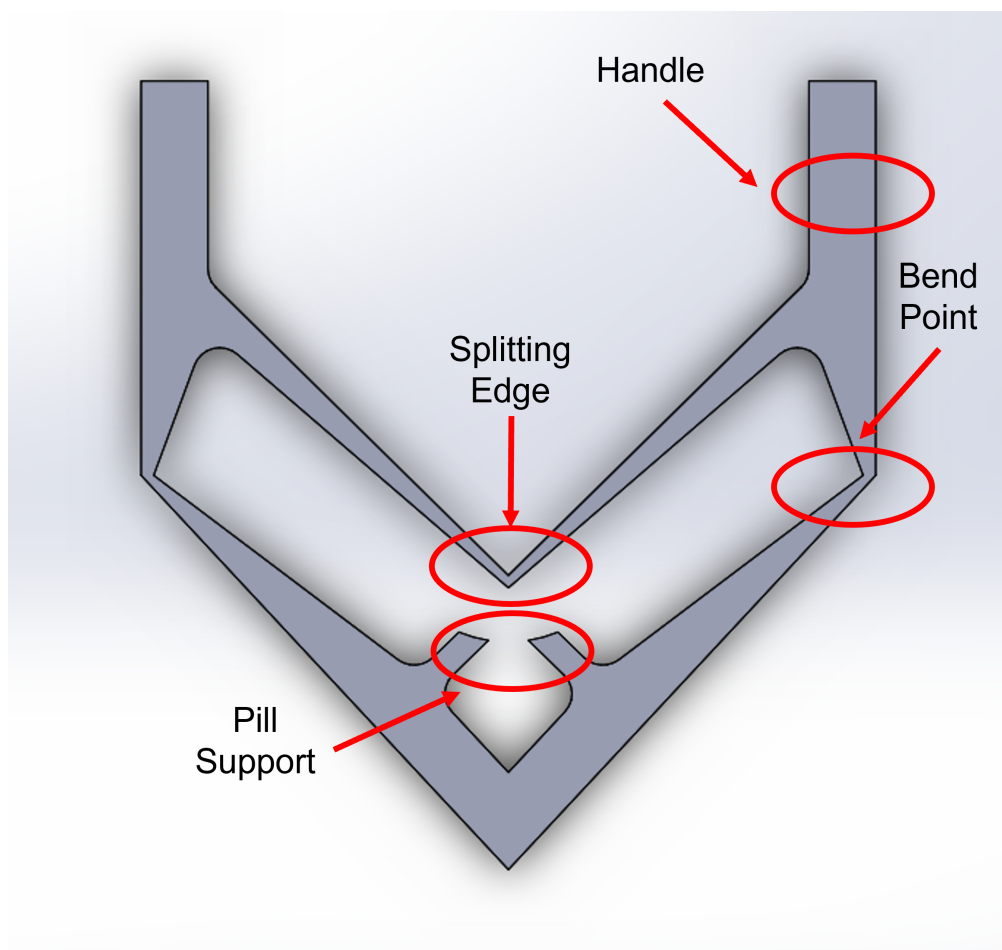

Figure 21: CAD model of Reverse Cookie method device.

The basic design of each version of the Reverse Cookie devices was the same. The user would press on the Handle and the Splitting Edge would deflect down. The pill would be resting on the Pill Support and the Splitting Edge would contact and split the pill. Figure 22 shows three versions of these Reverse Cookie compliant devices.

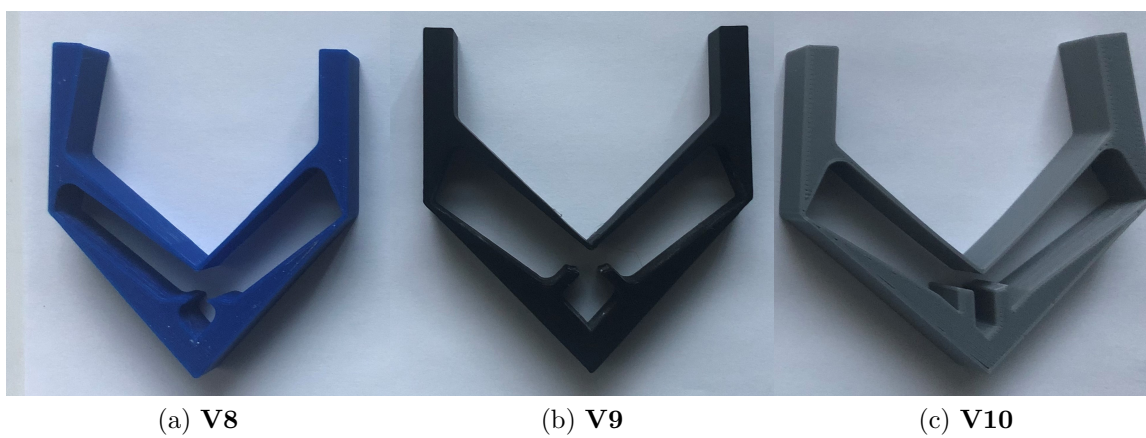

Figure 22: 3D printed prototypes of Versions 8-10 of for the Reverse Cookie Method device.

5.4.2 Version 8 Results and Discussion

Version 8 tended to split pills into 3 or more fragments. One issue was that the model was not actually symmetric due to a modeling error. This lack of symmetry caused the splitting edge to contact the pill off-center. There seemed to be some potential with this design if the splitting edge contacted the pill in the center.

5.4.3 Version 9 Results and Discussion

Version 9 was designed symmetrically indenting to rectify the contact point issue. While this version succeeded in fixing the contact point, it still crushed the pills. We suspected that the angle of the pill supports was too steep, causing the pill to crush before it could escape the well. The intent was to only apply a vertical reaction force through the Pill Supports. However, it appeared that the angle of the Pill Supports was causing the same volumetric issues as seen in the trough prototypes.

5.4.4 Version 10 Results and Discussion

Version 10 was an attempt to fix what was thought to be the issue with version 9. The Pill Support angle was changed to have a more vertical reaction force as opposed to one pushing the pill together. However, in the process of changing this model, another modeling error was made such that the splitting edge supports were no longer rigid enough to split a pill. However, as a result of multiple prototype failures in this type of loading, the team began to investigate the validity of this loading as a whole. This was done by furthering our study of the results from the FEM analysis performed on the the pill earlier in the semester.

6 FEM Analysis of Pill 3-Point Bending

The team analyzed the two types of loading conditions shown in Fig. 16 by running a SolidWorks Static Study. An idealized cross-section of the pill was modeled and analyzed using the material properties from Section 3.2. For each of the two loading configurations, the von Mises Stress and 1st Principle Stress were plotted.

6.1 Cookie Configuration

The Cookie Configuration assumes that two forces are applied to the upper face of the pill, one on the leftmost extremity and one on the rightmost extremity as seen in Fig. 24. A roller fixture at the center of the bottom face of the pill reacts the applied forces. Point loads cause unrealistically high-stress distributions at the point of application, so split lines were used to apply distributed forces at the upper extremities and a distributed fixture on the lower face.

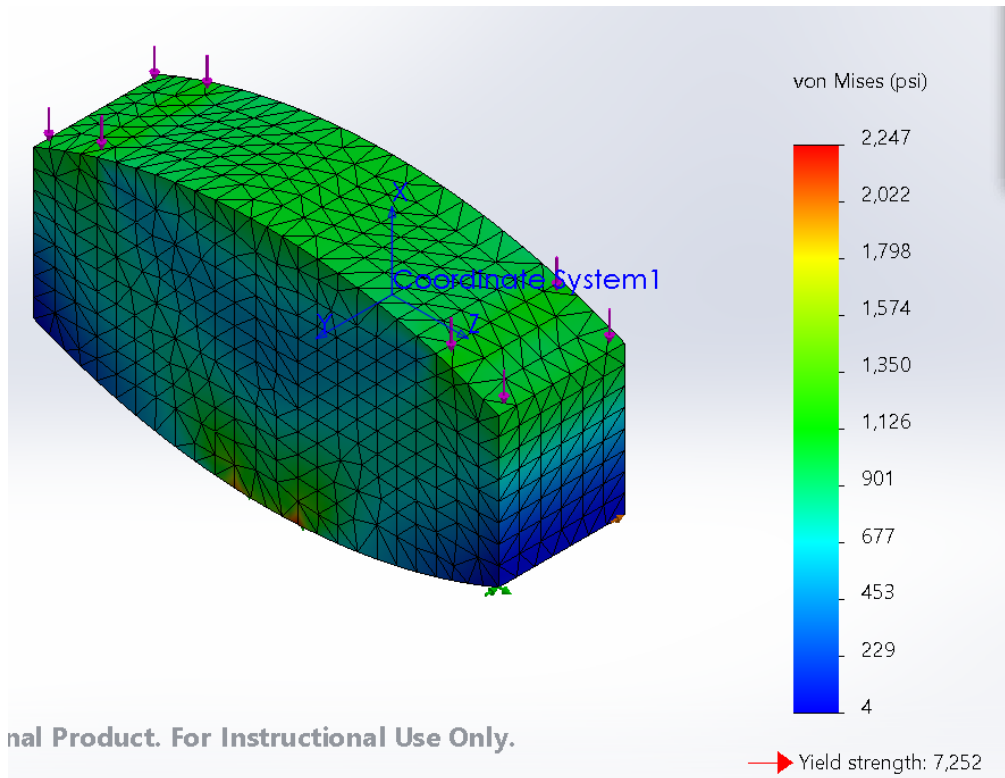

Figure 23: von Mises Stress results of pill under 3-point bending in cookie breaking configuration.

The FEM plot of the von Mises Stress (Fig. 23) reveals that the highest stress concentration is on the bottom face at the location of the fixture. In the plot of the 1st Principle Stress, black represents compressive stress (Fig. 24). So, the plot of the 1st Principal Stress reveals that the pill is in compression at the point of highest von Mises Stress. The location of highest von Mises Stress is where failure generally occurs, so our FEM analysis predicts the pill to fail under compression on the bottom face.

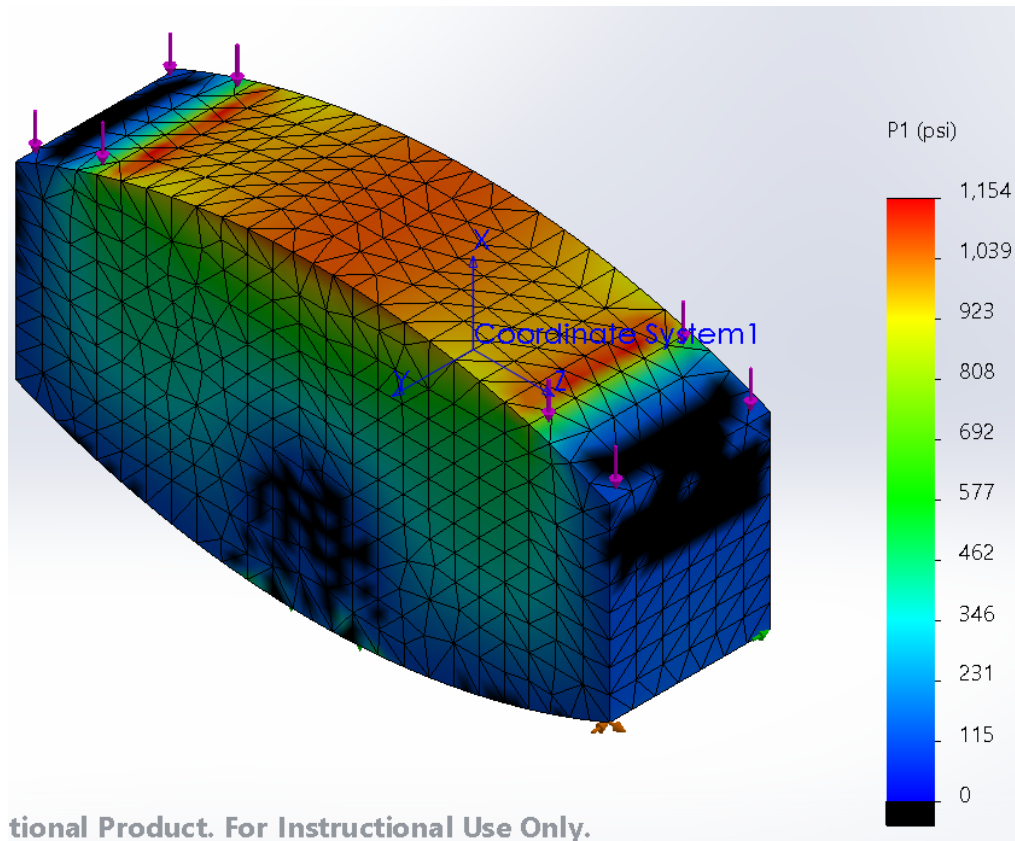

Figure 24: 1st Principle Stress results of pill under 3-point bending in cookie breaking configuration.

6.2 Reverse Cookie Configuration

The Reverse Cookie Configuration is modeled in a similar manner to the Cookie Configuration with the force and fixtures applied to sections. However, in this configuration, the load is actually a non-uniform distribution that sees its highest intensity towards the center of the load section. This was done because, in real life, a load applied at the center of the pill would have a similar non-uniform distribution. Figure 25 shows the von Mises Stress for this load configuration on the pill.

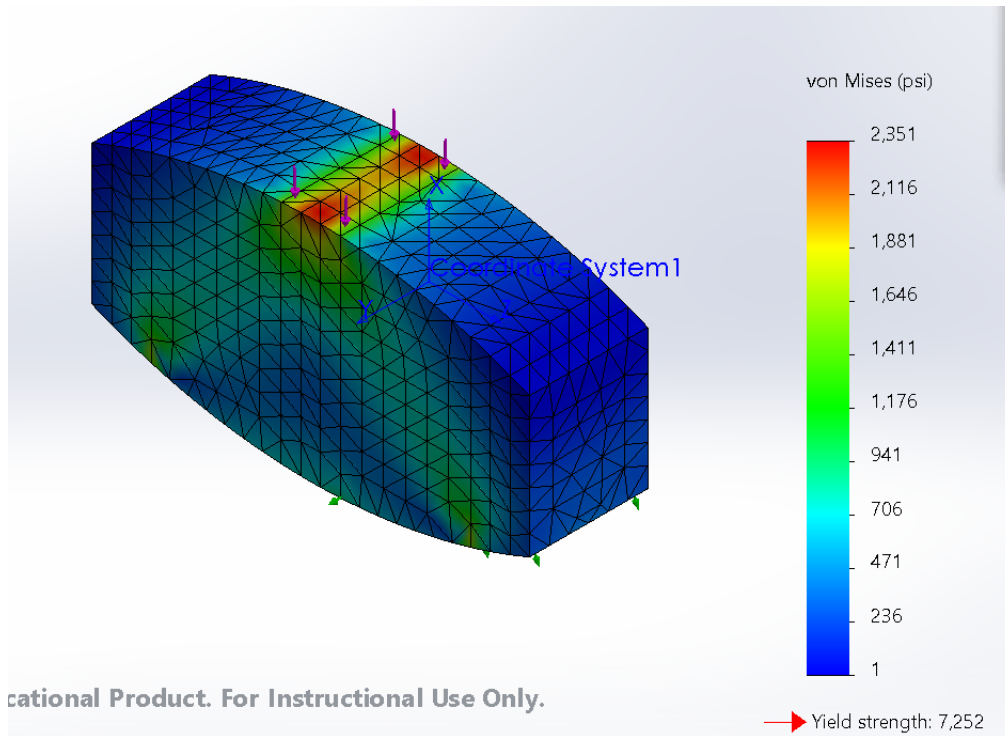

Figure 25: von Mises Stress results of pill under 3-point bending in reverse cookie breaking configuration.

The results show that the pill experiences its largest stress at the point of the applied load. In addition, this plot shows that the likely location for failure is at the location of the applied load.

Figure 26 shows the 1st Principle Stress for the pill under the Reverse Cookie load configuration.

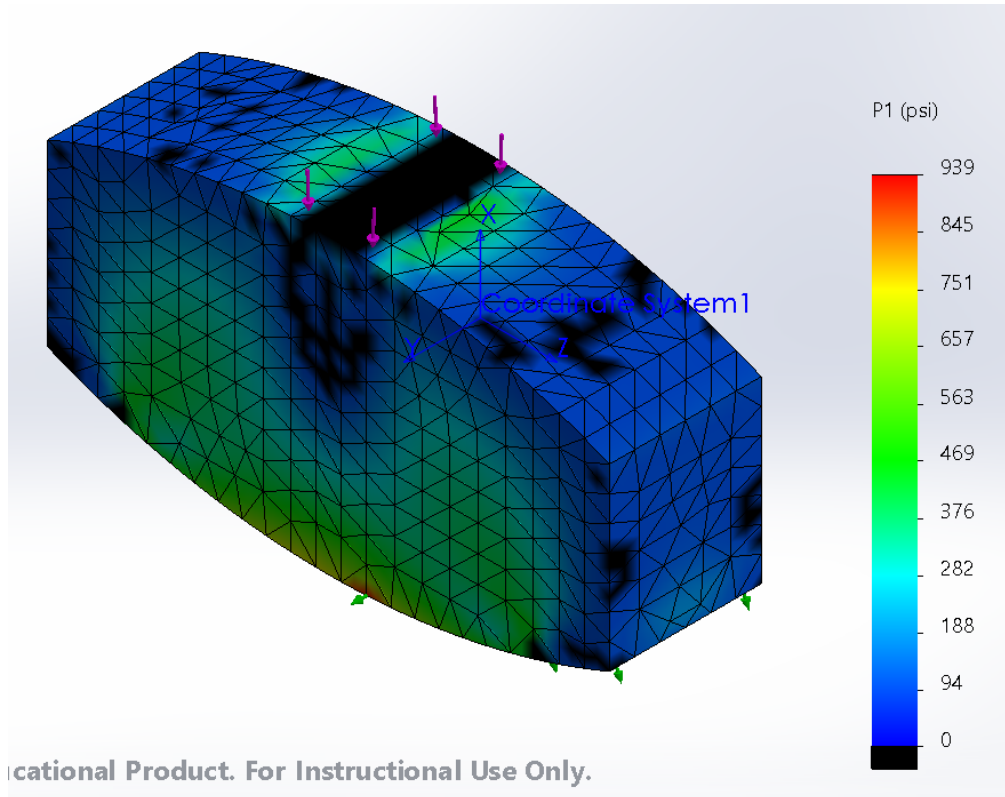

Figure 26: 1st Principle Stress results of pill under 3-point bending in reverse cookie breaking configuration.

In Fig. 26, all the stress below zero is shown in black. This helps to visualize the regions of the pill that are experiencing compression and tension. In this case, the stress in black is in compression. Figure 26 shows that the load location is experiencing compression. Therefore, in this configuration, the pill will fail in compression.

From the FEM analysis the team observed that in both configurations (Cookie and Reverse Cookie) the pill fails in compression. This is surprising as the pill was expected to fail in tension with the crack initiating on the top face, directly opposite of the fixture.

According to robsonforensic.com brittle materials are well known to be much stronger in compression than in tension [10]. This is because under a compressive load a transverse crack will tend to close up and so will not propagate.

Therefore, it is expected that the prototypes that used compressive bending mechanism would explode the pills while splitting because it requires a lot more force to break pills using compression method.

On the other hand, some of the pills still result in cleaner cut may be due to contact with the 3D printed sharp edges that breaks structural bond in certain line on the pill. Thus, it is not surprising to see that the pill splitting devices with metal cutter often make cleaner cut through stress concentration.

Lastly, four-point bending mechanism was implemented in later prototypes to test the hypothesis that our 3-point bending devices were unsuccessful due to high compressive loads

7 Final Prototype

The final prototype was created based on our real-life trials using 3D printed models and lessons from FEM. As discussed, the four-point bending method implemented in this final prototype should help to create a cleaner cut of the pill.



Figure 27: Dr. Potter's final 4pt bending prototype.

The final prototype was able to cleanly cut Dr.Potter's pills successfully, but it was not able to cut our pills. Since the major difference between the two situations was the difference in the material of the pill, we believe that the micro-structure of some pills is more favorable to our final prototype than others. Additionally, Dr. Potter's pills were chewable pills without a slick exterior coating. While the Ibuprofen pills used by the team had a lower friction coating on the pills. This coating likely played a role in the decrease in effectiveness between trials as the slick surface decreases the ability of the device to apply a tangential force on the pill (placing it in tension). This is problematic because the goal is to design a pill splitter that can split generic solid pills.

7.1 FEM 4-Point Bending

As with 3-point bending in the cookie break configuration, two distributed forces are applied to the pill, one on the rightmost extremity and one on the leftmost (Fig. 28). To represent 4-point bending, instead of a single distributed roller constraint located on the bottom face of the pill, two distributed roller fixtures are applied to the bottom face - symmetric about the center of the pill and equidistant between the center of the pill and the edge of the pill.

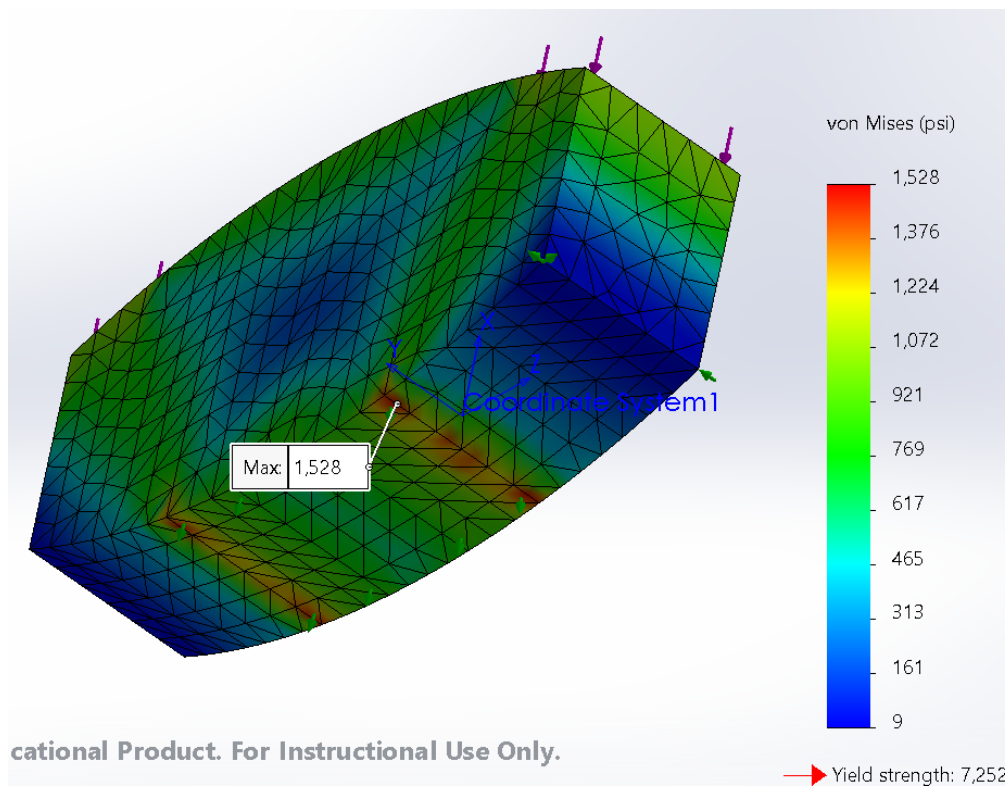

Figure 28: von Mises Stress for the 4pt bending load condition.

The plot of the von Mises Stress shows that the pill is most likely to fail at the roller constraints. This is problematic because a properly split pill must fail through the center of the bottom face, not to the side as predicted by the stress plot (Fig. 29). Experiments with the 3D printed 4-point bending pill cutter confirm that the pill does not fail in the center as desired. Images of these real life tests may be seen in Appendix B.

Figure 29 shows the 1st Principle Stress for the 4-point bending loading condition.

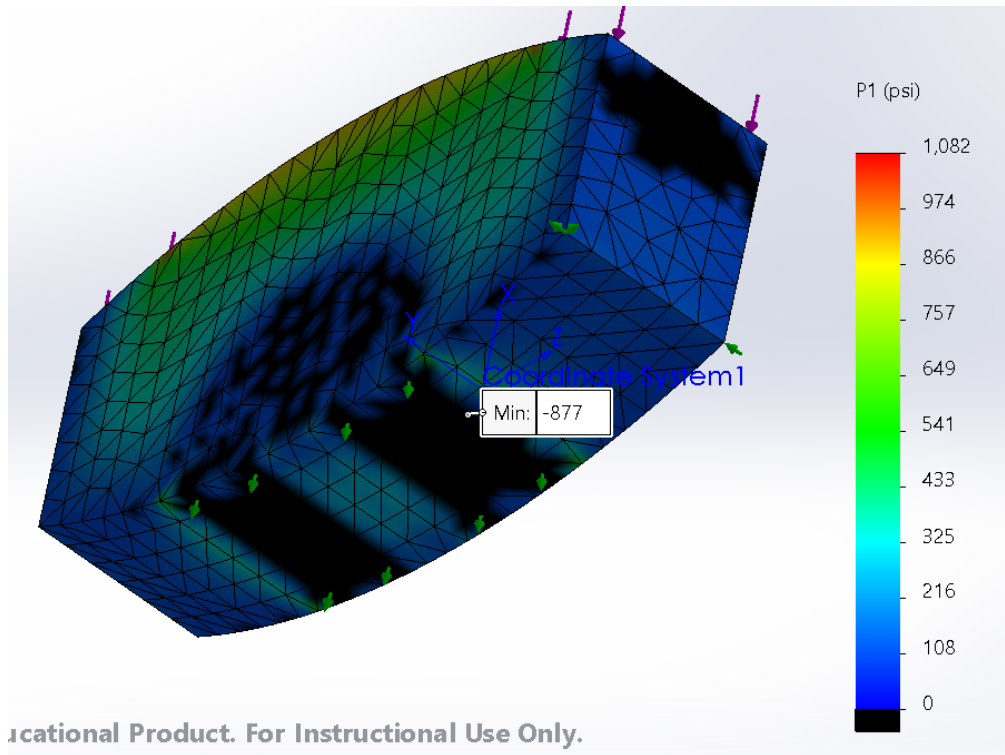

Figure 29: 1st Principle Stress for the 4pt bending load condition.

Similar to both 3-point loading cases, the stress below zero is shown in black. Therefore, by comparing the plot of the 1st Principle Stress to the plot of the von Mises Stress, it can be seen that the maximum von Mises stress occurs where the pill is in compression (Fig. 28). Therefore, similar to 3-point bending, the pill will fail in compression under 4-point bending.

8 Conclusion

Over the course of the semester, the team went through a number of design cycles as seen in Fig. 3. These design cycles were to validate the hypothesis that 3-point bending was a good means of splitting pills and to create a easily customize 3D printable version of the pill splitter.

The proof of concept demonstrations, such as the pill on a screwdriver (Fig. 1) or the initial prototypes from Dr. Potter (Fig. 14) showed promise. However, as the team moved to a different type of pill from the kind used by Dr. Potter (Melatonin to Ibuprofen), the prototypes did not show the same success rate. Dr. Potter's initial designs were unable to split the Ibuprofen pills. As a result, a different branch of prototypes was developed while continuing to work on Dr. Potter's prototypes. These prototypes were intended to amplify the force input to break the pills at a lower exertion from the user. Making use of compliant design techniques, these prototypes succeeded in amplifying the user force input but they failed either because the cutting arms were too elastic (Fig 18), allowing the pills to escape, or because of volumetric considerations, resulting in crushed pills - not split pills (Fig. 22). After our failures, we decided to perform FEM analysis to see if this might shed some light on our pill crushing problem.

We analyzed two 3-point bending load configurations with FEM, the Cookie and the Reverse Cookie Methods (Fig 16). For both cases, the von Mises Stress and the 1st Principle Stress were analyzed. For both load configurations, the max von Mises Stress (the location where the pill was

likely to fail) was in compression as seen from the 1st Principle Stress (Figs. 23 - 26). Therefore, under both load configurations of 3-point bending, the pills fail in compression. This is problematic because objects require higher stresses to fail in compression than in tension, meaning that designs utilizing this method must be able to withstand higher stresses than designs that cause pills to fail in tension. Additionally, failing in compression means that the material is being squished together as it fails. In other words, the material is crushed, which is the problem we have experienced in all of our most promising designs.

The final prototype used 4-point bending instead of 3-point bending. The hope was that 4-point bending more closely resembled the breaking of a cookie (Fig. 17). However, the final prototype failed to split pills consistently. When the prototype was able to split pills at all, the crack was generated off center and propagated at an angle towards the pill edge (see Appendix B). A FEM analysis was performed for 4-point bending load case. The results of the study showed agreement with the testing results. In addition, the FEM showed that under 4-point bending, the pill still failed in compression (Figs. 28 and 29).

Future work should pursue a pill cutter design that causes pills to fail in tension. Tension failures are desired because, by definition, the material is being pulled apart and does not crush itself.

Finally, we had intended to devise a method for rapid customization of the pill splitter to various pill sizes. Unfortunately, because we did not succeed in designing a splitter that would split pills consistently, we did not develop a scheme that would allow users to easily customize the 3D print file to a pill size of choice. After developing a successful 3D printed pill splitter, the next priority would be to design an easily customizable CAD file so that makers can resize the splitter to cut pills of any size.

Bibliography

- [1] Andrew Brown et al. “MEMS 411: Fast Pill Cutter”. In: *Mechanical Engineering Design Project Class* (Apr. 2021). URL: <https://openscholarship.wustl.edu/mems411/138>.
- [2] Dan Ma et al. “Effects of height/diameter ratio on failure and damage properties of granite under coupled bending and splitting deformation”. en. In: *Engineering Fracture Mechanics* 220 (Oct. 2019), pp. 106–640. ISSN: 0013-7944. DOI: [10.1016/j.engfracmech.2019.106640](https://doi.org/10.1016/j.engfracmech.2019.106640). URL: <https://www.sciencedirect.com/science/article/pii/S0013794419308550> (visited on 09/20/2021).
- [3] C. M. Peret and J. A. Rodrigues. “Stability of crack propagation during bending tests on brittle materials”. In: (Sept. 2008), pp. 382–387. URL: <http://www.scielo.br/j/ce/a/BqQgwSFTSbM8Fv3nQyxjY6K/abstract/?lang=en>.
- [4] Kai-Erik Peiponen et al. “Estimation of Young’s modulus of pharmaceutical tablet obtained by terahertz time-delay measurement”. en. In: *International Journal of Pharmaceutics* 489.1 (July 2015), pp. 100–105. ISSN: 0378-5173. DOI: [10.1016/j.ijpharm.2015.04.068](https://doi.org/10.1016/j.ijpharm.2015.04.068). URL: <https://www.sciencedirect.com/science/article/pii/S0378517315003889> (visited on 10/28/2021).
- [5] *Determination of tensile strength of shaped tablets — Elsevier Enhanced Reader*. en. DOI: [10.1016/j.powtec.2021.01.014](https://doi.org/10.1016/j.powtec.2021.01.014). URL: <https://doi.org/10.1016/j.powtec.2021.01.014> (visited on 12/14/2021).
- [6] Sim Sotcheadt. *Mach-1-3-point or 4-point Bending Test*. URL: <https://www.biomomentum.com/wp-content/themes/biomomentum/library/images/zoho/Publications/MA056-SOP11-D%20v2%20Mach-1%20-%203-point%20or%204-point%20Bending%20Test.pdf>.
- [7] S. Rodrigues-Junior, A. D. Bona, and J. L. Ferracane. “Flexural strength and Weibull analysis of a microhybrid and a nanofill composite evaluated by 3- and 4-point bending tests”. en. In: *Dental materials: official publication of the Academy of Dental Materials* 220 (May 2007), pp. 426–431. DOI: [10.1016/j.dental.2007.05.013](https://doi.org/10.1016/j.dental.2007.05.013). URL: https://www.researchgate.net/publication/6158839_Flexural_strength_and_Weibull_analysis_of_a_microhybrid_and_a_nanofill_composite_evaluated_by_3-_and_4-point_bending_tests/stats (visited on 12/20/2021).
- [8] Baier Lacey. URL: https://en.wikipedia.org/wiki/Automatic_center_punch.
- [9] Veritasium. *Why Machines That Bend Are Better*. Mar. 2019. URL: https://www.youtube.com/watch?v=97t7Xj_iBv0 (visited on 12/14/2021).
- [10] James Derby. *Failure Analysis of Glass Other Ceramic Materials - Expert Article*. URL: <https://www.robsonforensic.com/articles/glass-ceramic-expert-witness/>.

A Hand Calculations

pill

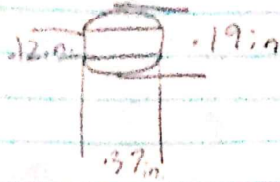

$$.19 - .12 = .07 \quad y$$

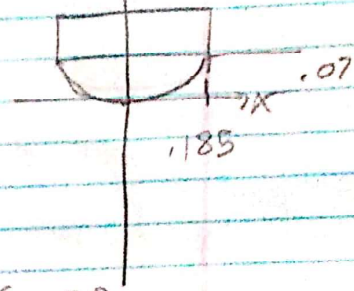

$$y = Ax^2 + Bx + C$$

if $x = 0$

$$y = A(0) + B(0) + C = 0$$

$$C = 0$$

$$\text{if } x = .185 \quad y = A(.185)^2 + B(.185) = .07$$

$$\text{if } x = -.185 \quad y = A(-.185)^2 - B(.185) = .07$$

$$\begin{bmatrix} .185^2 & .185 \\ -.185^2 & -.185 \end{bmatrix} \begin{bmatrix} A \\ B \end{bmatrix} = \begin{bmatrix} .07 \\ .07 \end{bmatrix}$$

$$\begin{bmatrix} 1 & 0 \\ 0 & 1 \end{bmatrix} \begin{bmatrix} A \\ B \end{bmatrix} = \begin{bmatrix} 2.045288 \\ 0 \end{bmatrix}$$

$$A = 2.045288$$

$$B = 0$$

$$y = 2.045288x^2$$

or for top half
of pill,

$$y = -2.045288x^2 + .06 \text{ in}$$

hanger $D = .07$ in

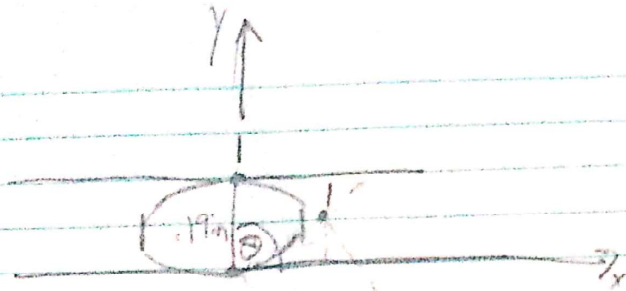

$$y_1 = .19 \sin \theta$$

$$y_1 = .19 \frac{\sqrt{.19^2 - x^2}}{.19}$$

$$y_1 = \sqrt{.19^2 - x^2}$$

$$\sin \theta = \frac{\text{opp}}{\text{hyp}}$$

$$\text{hyp} = .19$$

$$\text{opp} = y$$

$$\sin \theta = \frac{y}{.19}$$

$$\sqrt{x^2 + y^2} = .19$$

$$y^2 = .19^2 - x^2$$

$$y = \sqrt{.19^2 - x^2}$$

for if pivot point is directly at bottom of pill

y_1

$$\sin \theta = \frac{\sqrt{.19^2 - x^2}}{.19}$$

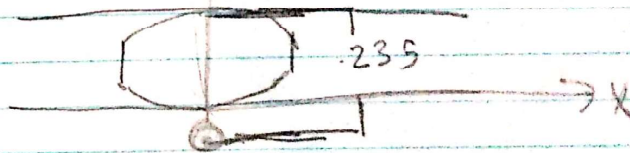

$$y_1 = \sqrt{.235^2 - x^2} = .045$$

B 4-Point Final Prototype Testing

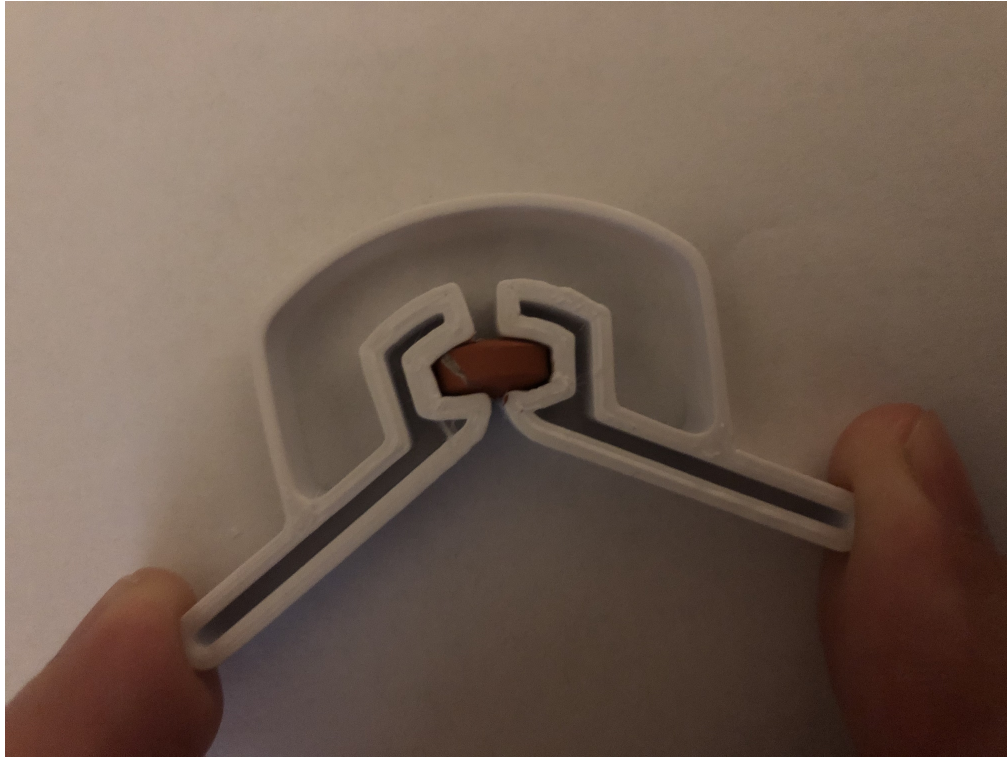

Figure 30: Shows crack propagation in the pill.



Figure 31: Shows crack propagation in the pill.



Figure 32: Pill testing results from the additional prototypes.