

University of Nebraska - Lincoln

DigitalCommons@University of Nebraska - Lincoln

Library Philosophy and Practice (e-journal)

Libraries at University of Nebraska-Lincoln

Spring 12-2-2021

Digitization of Academic Libraries through Cloud Environment

Sivankalai S

Hindustan Institute of Technology and Science (Hindustan University), skysivan@gmail.com

Virumandi A

Service Delivery, Manager, Precision Informatics (M) Pvt Ltd., Chennai, virums@gmail.com

Sivasekaran K

Librarian, Ayya Nadar Janaki Ammal College, Sivakasi. India, sivasekarank@gmail.com

Jeyanthi R

Librarian E.M.Gopalakrishna Kone Yadava Women's College, rjeyanthi2005@gmail.com

M Sharmila

Technical Assistant, Mother Teresa Women's University, Kodaikanal,, ssasbwins@gmail.com

Follow this and additional works at: <https://digitalcommons.unl.edu/libphilprac>



Part of the [Computer and Systems Architecture Commons](#), [Data Storage Systems Commons](#), [Higher Education Administration Commons](#), [Other Computer Engineering Commons](#), and the [Other Educational Administration and Supervision Commons](#)

S, Sivankalai; A, Virumandi; K, Sivasekaran; R, Jeyanthi; and Sharmila, M, "Digitization of Academic Libraries through Cloud Environment" (2021). *Library Philosophy and Practice (e-journal)*. 6653. <https://digitalcommons.unl.edu/libphilprac/6653>

Digitization of Academic Libraries through Cloud Environment

Sivankalai, S^{1*} Virumandi, A² Sivasekaran, K³ Jeyanthi, R⁴ Sharmila, M⁵

¹Chief Librarian, Hindustan Institute of Technology and Science (a Deemed to be University), Chennai

Orcid Id: 0000-0002-1174-7594 *Corresponding author skysivan@gmail.com

²Service Delivery, Manager, Precision Informatics (M) Pvt Ltd., Chennai
virums@gmail.com Orcid: 0000-0003-1337-3714

³Librarian, Ayya Nadar Janaki Ammal College, Sivakasi, India.
sivasekarank@gmail.com Orcid Id: 0000- 0003-0021-7819

⁴Librarian E.M.Gopalakrishna Kone Yadava Women's College,
Madurai -14. rjeyanthi2005@gmail.com

⁵Technical Assistant, Mother Teresa Women's University, Kodaikanal,
ssasbwins@gmail.com Orcid: 0000-0002-4010-7924

Abstracts

Libraries may soon be able to establish and manage their own data centres. This paradigm would allow libraries to control the apps and data stores that include sensitive and private information about their users' personal and financial information. The provisioning and management of infrastructure for a Web-based digital library present several complicated difficulties for library administrators. In this article, we address the challenges that digital libraries confront, and the efforts being made to solve those challenges. Infrastructure virtualization and cloud Environment are incredibly enticing options, but they are being challenged by the expansion of the indexed document collection, the addition of new features, and, most importantly, the increase in consumption. The study covers the current state of user service models in academic libraries to bring Cloud Environment to academic libraries soon. Then it advocated that Cloud Environment be used to enhance the present user service delivery paradigm. This study investigates some of the security challenges that arise in the context of data location, mobility, and accessibility. On the one hand, cloud Environment, technological interventions, curriculum overhaul, experiential learning, multi-disciplinary approaches, as well as continuous innovation and digitization are discussed in this paper as strategies that academic libraries can use to deal with emerging issues related to teaching and learning processes.

Keywords: Digitization, Digital Library, Digital Resources, Academic Libraries, Cloud Environment

Introduction

A new IT technology, Cloud Environment, has been dubbed the "third revolution" after the PC and the Internet. Cloud Environment is a form of distributed computing, including distributed databases, parallel computing, grid computing, and grid computing. When it comes to Cloud Environment, the essential aspect is to distribute tasks among many distributed computers, rather than on a single local computer or an external server. In another way, Cloud Environment can gather a large amount of data and resources from various devices and put them on a public cloud for users to access. By integrating hardware and software, each type of carrier digitization is carried out effectively, and the organization provides the network with an effective service through the digital library. Cloud Environment: Implications, Risks, and Challenges look at the latest technology and tools being used in academic libraries to study learning. As a new and emerging technology, the integration of academia and industry into cloud Environment improves the quality of higher education. Academic libraries have been forced to rethink their strategies for survival and growth because of technological disruptions in recent years, according to Thoring, A., Et al (2017). Educators must now constantly upskill and reskill to meet future work needs, particularly in the digital age, as cloud Environment accelerates in academic libraries. If the lack of relevant skills to deal with the disruptions in higher education isn't addressed quickly, it will become a huge problem. As part of Education 4.0, academic libraries align themselves with cloud Environment and prepare faculty and students for the changes in the Digitization process. Both academia and industry have been forced to rethink their strategies for survival and growth because of recent technological disruptions faced by academic libraries. Educators must now constantly upskill and reskill to meet future work needs, particularly in the digital age, as cloud Environment accelerates in academic libraries. If the lack of relevant skills to deal with the disruptions in higher education isn't addressed quickly, it will become a huge problem. As part of Education 4.0, academic libraries align themselves with cloud Environment and prepare faculty and students for the changes in the Digitization process.

Reasons for Digitization Academic Libraries

For example, the proliferation of electronic information, the shrinking budget for library stock acquisition, the desire to access materials in remote locations, the pursuit of collaboration, partnerships, and resource sharing, and the ever-increasing cost of preserving

analogue materials are some of the forces that have prompted the digitization of archives and records. Digitizing library items aim to ensure their long-term preservation while also making them accessible to any user or researcher. Access to library materials is become more accessible because of digitization. By digitizing library collections, information will become available to the public rather than just a small group of scholars. When working on digital projects, users can search for readers quickly and thoroughly from any location at any time. The advent of digitization allows the previously inaccessible to become apparent. Multiple users may view the same information at the same time without encountering any difficulties. As a bonus, it eliminates the issue of distance, as users no longer must go to libraries that hold tangible copies of library resources before accessing and utilising such contents (Fabunmi, B. A., Et al 2009).

The digitization of academic libraries using a cloud environment

When embarking on digitization initiatives in underdeveloped nations, several considerations must be considered. These considerations include the phases outlined below.

- **Enactment of policies**

- A policy is a directive.
- Top management should adopt a project policy.
- This policy will serve as a guideline for implementing the development.
- The policy should state the development's targets.
- It is essential to be certain about the types of users who will access the collection through cloud environments
- materials they may be involved in, how they will use it, in what way several people will use it, how
- it will be advertised, and the material's benefit to end-users and institutions.
-

- **Approval of the policy**

The proper authority should approve the implementation of the policy for digitization. For example, a higher education colleges/university's digitization requires the approval of the academic libraries' administration and further funding agencies. A policy changes.

- **Preparation, Budgeting, and Keeping Track**

Set up a planning committee to draw up the plan and budget for the digitization

exercise. Budgets for digitization projects should include Wages and benefits, Staff training, supplies, contracts, and legal fees, H&O & indirect costs, adversity. The development's goals, funding source, and budget should all be considered. Effective regional or national digitization planning can benefit all types of libraries, museums, academic/professional societies, historical societies, and archives.

- **Obtaining the Appropriate Equipment**

To provide information services with no limits to traditional and academic libraries, they shifted to electronic libraries. The library's resources could be accessed from any location, at any time, by library users. The evolution of library services in the United States contributed to developing a learning society and a lifelong learning environment. These changes have been made possible thanks to the introduction of computer technology and automated library systems in the library. This paper focuses on the acquisition and implementation of technology that affects this development (Sujin Butdisuwan 2009).

- **Administration's final decision on how the procedure will be implemented**

The functionality should always be decided upon, whether to establish links with other digital libraries, visualize in-house, or contract it out. Setting a deadline for the project is essential.

- **Preparation, Adaptation, and Reinforcement of Employees**

Most institutions' employees would prefer to oppose the digitization effort. People often resist change because they are afraid of the unknown. The library staff may be concerned that the project's success could negatively impact their jobs. There is a risk that those who are not computer literate will not adapt. Many of these groups have legitimate reasons to oppose. To alleviate their apprehensions, the university's organization must teach them as well as provide answers.

- **Lawsuits involving intellectual property rights and copyright law**

Who is the owner? A thorough grasp of copyright law and copyright rights is required before selecting archive assets for digitalization. Does ownership imply reproduction rights? Physical ownership does not imply reproduction rights by such an institution.

The source materials' copyright status will be one of the more significant specific criteria for digitization. Will authorization to digitize be granted? Will the institution be able to manage the rights to the digital assets after digitization? A digital project should not be undertaken unless the organization has the right to digitize and manage digital assets.

- **Criteria for selection**

Libraries and archives are digitizing rare and distinctive artefacts in special collections to make them more widely available. Digitization programmes and collection selection processes have been made more user-friendly by completing a central component of the evaluation, consultation, and user engagement. The digital collections of institutions must also reflect their goals. Selecting and constructing meaningful and useable digital special collections that balance user and institutional interests while addressing the demands of key stakeholders is the focus of this essay (Mills, A. 2015).

- **Verifications**

Cloud Environment hardware and software licencing, training of librarians in new technologies, and hiring professionals with web technologies abilities to support and manage the resources to be digitized are some of the costs associated with an academic library. The copyright owners must be contacted, and the appropriate permissions secured (Adeniran, P. 2014).

- **Metadata**

Metadata creation the information for digital items must be created manually or automatically. Archivists should not treat analogue object metadata as digital surrogate information. They may share some, but they also vary. Descriptive, technical, and provenance information are unique to each digital item and include the object's inventor, digitization date, physical characteristics, and probable file structure. The cataloguing rules should be properly established (Lina Bountouri, 2017).

Collaborative and group digitization in a cloud environment

Academic institutions, university and college libraries have all become linked to the Internet, intranets, and extranets through proxy-server-based networks, and they are giving access to relevant e-journals and e-books via these networks. When it comes to serving clients in a cloud-based environment, academic library services may need to adapt. Infrastructure provisioning and end-user service libraries may be separated in a cloud environment, making

it easy to decouple these two processes. Users of cloud Environment may pool resources and services belonging to various businesses or locations for the benefit of everyone (Kaur, G. 2015). Library employees working together to establish two Web databases based on their expertise in long-standing library services, including cataloguing and systems, archives and selection is detailed. As a result of the combined effort, materials were processed, archiving and digitization were done efficiently and effectively. Information on the duties of the various library departments engaged in the digitization project is provided (Boock, M., Jeppesen, B., & Barrow, W. 2002).

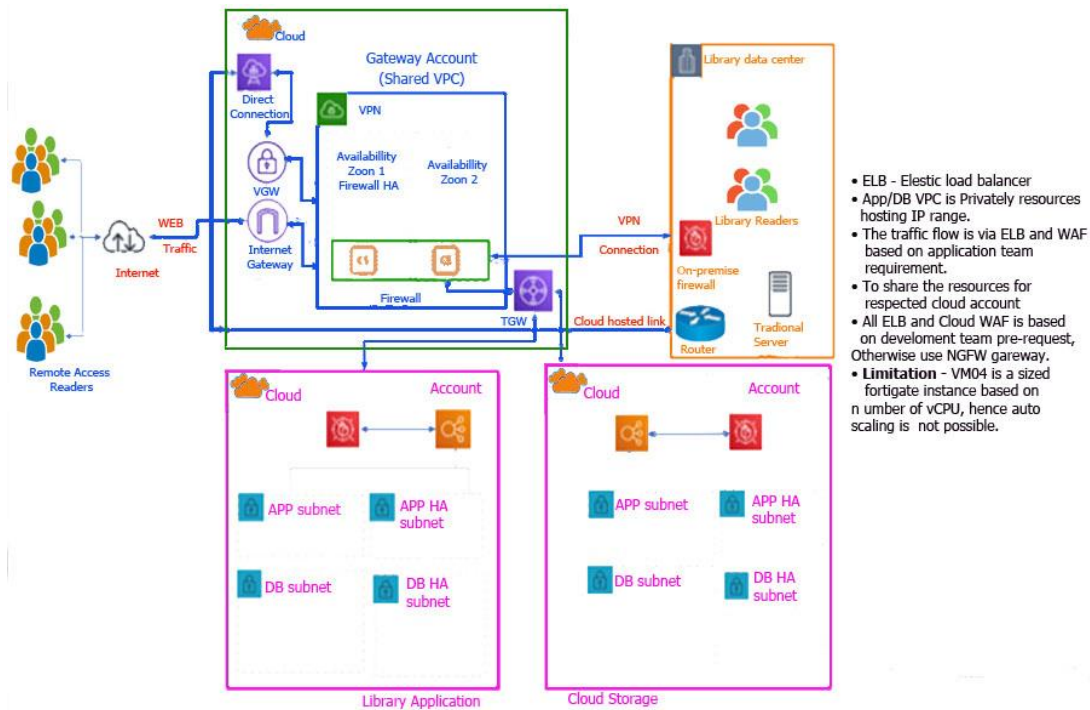

Figure 1. Library Digitization in a Cloud Environment

Text quality

Text resources include books, periodicals, newspapers, original manuscripts, letters, notes, and other documents. For digitizing purposes, "text" refers to any representation of words on a physical medium, such as paper. Depending on the collection's purpose, several text digitization methods may be utilized. In other circumstances, libraries are solely concerned with the book's content, not the medium of communication. In most collections, it is ideal for digitizing the text content and the visual characteristics of the text, such as font, formatting, arrangement, and paper quality. Line drawings, pictures, graphic images, manuscripts, music scores, blueprints, plans, etc., commonly accompany the text. Due to its dual nature, text digitization is highly comparable to visual content digitalization. Additional

procedures must be done to make the text machine-readable to enable full-text searches or indexing. Text materials also have the further difficulty of having numerous pages (like a book) or having many articles on a single page (such as a newspaper). A "work" is defined as a single page, an article, an issue or volume, and the digitization process should be carried out appropriately.

Images Quality

The simplest method involves scanning the physical medium onto which the text has been pasted to generate a digital picture representing the work's content. Digitized facsimiles carry all visual information included in a text, but they do not enable text indexing and searching; further steps must be done to accomplish this.

Audio or Video Quality

The visual and audio components are the two most important aspects of a video (audio). The audio is equally as crucial as the video, if not more so, when educational filming a video, so be sure to pay close attention to the audio and visual elements of the educational project.

Standards

It is our responsibility to preserve the long-term value and usability of our digital collections and safeguard the investment that has been made in them by creating and managing our digital collections appropriately. "Archive masters" that may be used for an extended period in the most cost-effective way are of significant value. Created derivatives of the rich archive master may then be utilized to fulfil present and future users' diverse demands. The quality of the original scan will have a direct impact on the quality and utility of different derivatives (e.g., for distribution or picture presentation). (Ambati, V., Et al. 2005).

Quality of Optical Character Recognition

There are a variety of methods for correcting OCR output depending on the language's knowledge. The dictionary of the language has this information. The OCR result is validated against the dictionary for each word. Any term not found in an existing dictionary is tested against an alternative, or "reverse," dictionary. In this way, it is possible to pinpoint where the OCR may have made an error in translating a particular character. It's also possible to create a probabilistic model based on the distributions of the characters in a storey using the pairwise

technique. Using this model, you can see what alternative characters could come after the identified character. This gives us the ability to fine-tune the OCR and dramatically enhances the accuracy of returns. But it would need a large amount of training data (Ambati, V., Et al. 2005).

Risks and challenges in cloud platforms for Academic libraries

In today's digital world, academic libraries are battling to maintain their status as primary sources of information. Many library users (mainly digital natives) have higher expectations from librarians and information workers than ever before to get the knowledge and expertise they need whenever they need it (Jain, 2013). In the digital age, library digitization has become a significant impetus for academic libraries to adopt ICT and digitize library resources because of its many benefits, including faster access to library materials, multiple users accessing the same information at the same time, eliminating the problem of distance, and improving library services (CLN, O. O., Abu, L., & Ekeniyere, I. A. 2018).

Lack of proper direction

No proper direction from the management for digitization of academic libraries leads to negligence of it.

Lack of technical training:

An influence on librarian education from the growth of digital libraries is being felt. Training for new librarians is becoming more difficult since they must learn to work with digital forms through cloud environments.

Lack of needed infrastructure

ICT infrastructure development is a severe problem for these nations. Development countries, it is argued, face similar issues and challenges in terms of the availability of good ICT infrastructure, reliable electric power sources, high internet bandwidth and ICT equipment costs and a lack of technical expertise to manage the life cycle support of technological advancement. With the aid of global forces and partners, developing nations must cope with the current ICT infrastructure gaps to integrate their economies and expedite the development progress toward the TIN Sustainable Development Goals (Boachie, F. K. 2018).

Employee experience

A digital workplace promotes efficiency and productivity by providing a single location for workers to access their work-related data. It also allows workers to concentrate on their job rather than jumping between many programmes or continuously looking for the information they need in various apps.

Lack of support from management

The administration of university libraries does not provide adequate assistance for the digitalization of their collections.

Lack of long-range planning

- Researchers will benefit intellectually from the collection.
- Current or future customers' demand
- The collection's focus is on a specific time or region.
- Do other institutions have the same or comparable content digitized?
- Is the material appropriate for digitization based on its physical condition? Preservative work may be required before digitization; bound volumes should be able to be opened to at least a 90-degree angle for scanning; maps may have to be drastically reduced for online display, resulting in a loss of fine detail and geographical context.)
- Creative Commons licence (if the materials are not in the public domain, you must have permission from the copyright owner to digitize the material).

Conclusion

Increasing student access to mass-digitized resources is the most significant advantage of all academic libraries through Cloud Environment, and this is especially true for that current COVID-19 pandemic situation in higher education institutions. As part of a complete strategy plan, librarians and academic administrators should lobby in favour of likened access to the mass-digitized resource for the library to reclaim its position as a critical component of the academic enterprise through cloud technology. This research aimed to examine the objective of cloud-based digitization, the resources that should be cloud-based digitized, and the obstacles that stand in the way of efficient cloud-based digitalization of library materials. Results reveal that academic libraries are digitizing their resources to provide more access to library materials, more effective preservation of library materials, enhanced library service, faster retrieval of documents, and greater exposure to the institution's collections through cloud Environment technology. Despite the many advantages associated with the cloud-based

digitization of library resources, there are still several obstacles to overcome to achieve efficient digitization through cloud Environment technologies.

References

1. Adeniran, P. (2014). The Challenges of successful implementation of virtual libraries in academic libraries in Nigeria. *Academic Research Journal*, 2(4), 46-50.
2. Ambati, V., Sankar, P., Pratha, L., & Jawahar, C. V. (2005). Quality management in digital libraries. In *International Conference on Universal Digital Library, Hangzhou, PR China, Zhejiang University Press*.
3. Boock, M., Jeppesen, B., & Barrow, W. (2002). Getting digitization projects done in a medium-sized academic library: A collaborative effort between technical services, systems, special collections, and collection management. *Technical Services Quarterly*, 20(3), 19-31.
4. CLN, O. O., Abu, L., & Ekeniyere, I. A. (2018). Prospects and Challenges of Digitization of Academic Libraries Resources for Effective Services Delivery in Universities In Edo State. *International Research: Journal of Library and Information Science*, 8(2).
5. Fabunmi, B. A., Paris, M., & Fabunmi, M. (2009). Digitization of library resources: Challenges and implications for policy and planning. *International Journal of African & African-American Studies*, 5(2).
6. Kaur, G. (2015). The future and changing roles of academic libraries in the digital age.
7. Lina Bountouri, (2017) Digitization, Archives in the Digital Age, Chandos Publishing, 29-36, ISBN 9781843347774, <https://doi.org/10.1016/B978-1-84334-777-4.00003-7>
8. Mills, A. (2015). User impact on selection, digitization, and the development of digital special collections. *New Review of Academic Librarianship*, 21(2), 160-169.
9. Sanchati, R. (2011). Cloud computing in digital and university libraries. *Global Journal of Computer Science and Technology*.
10. Sivankalai, S. (2014). Use of Electronic Resources among the Faculty Members at Paavai College of Engineering (PCE), Namakkal Distric-A Study. *Asia Pacific Journal of Library and Information Science*, 3(1).
11. Sivankalai, S. (2017). Engineering College Students' utilization of Open Source Learning Management Systems: A Survey. *Shanlax International Journal of Arts, Science and Humanities*, 5(2), 54-61.
12. Sivankalai, S. (2018). A study on information literacy services on the use of college digital

resources among under graduate students in EIT library. *International journal of scientific research*, 6(9).

13. Sivankalai, S. (2020). Awareness of Library Automation among the Professionals in Academic Libraries at State of Eritrea. *International Journal of Academic Library and Information Science*, 8(1), 17-21.
14. Sivankalai, S. (2021). Academic Libraries' Content Management Trends. *Library Philosophy and Practice (e-journal)* 8 (19), 1-13
15. Sivankalai, S. (2021). Academic Libraries support E-Learning and Lifelong Learning: a case study. *Library Philosophy and Practice (e-journal)* 8 (18), 1-18
16. Sivankalai, S. (2021). The Impact of Cloud Computing on Academic Libraries. *Library Philosophy and Practice (e-journal)* 9 (3), 1-17
17. Sivankalai, S. A study on teaching and learning support systems using digital libraries with special reference to biological sciences.
18. Sivankalai, S., & Sivasekaran, K. (2021). ICT based learning for readers of higher education through library system. *Impact of Information and Communication Technology on Library Environment*, 135-148.
19. Sivankalai, S., & Thulasi Kavitha Yadav, S. (2012). Total quality management in academic libraries: A study. *International journal of educational research and technology*, (1), 66-72.
20. Sivankalai, S., & Virumandi, A. (2021). Web Services in Cloud Computing research: Insights from Scientometric. *Library Philosophy and Practice (e-journal)* 6 (27), 1-23
21. Sivankalai, S., Virumandi, A., & Chellapandi, P. (2014). A Study of Engineering Student's Approach on Digitization with Special Reference In Academic Library. *E-library science Research Journal*, 2.
22. Sujin Butdisuwan (2009) Acquisition and Deployment of Technology in Academic Library Environment: Experience in Thailand. *Ical 2009 – Technology, Policy and Innovation* 281-286
23. Thoring, A., Rudolph, D., & Vogl, R. (2017). Digitalization of higher education from a student's point of view. *EUNIS 2017–Shaping the Digital Future of Universities*, 279-288.

.