



## UvA-DARE (Digital Academic Repository)

### Applied health research manual

*Anthropology of health and health care*

Hardon, A.; Boomongkon, P.; Streefland, P.; Tan, M.L.; Hongvivatana, T.; van der Geest, S.; van Staa, A.; Varkevisser, C.; Acuin, C.; Chowdhury, M.; Bhuiya, A.; Sringeriyuang, L.; van Dongen, E.; Gerrits, T.

#### Publication date

2001

#### Document Version

Final published version

[Link to publication](#)

#### Citation for published version (APA):

Hardon, A., Boomongkon, P., Streefland, P., Tan, M. L., Hongvivatana, T., van der Geest, S., van Staa, A., Varkevisser, C., Acuin, C., Chowdhury, M., Bhuiya, A., Sringeriyuang, L., van Dongen, E., & Gerrits, T. (2001). *Applied health research manual: Anthropology of health and health care*. (3rd, rev. ed.) Het Spinhuis.

#### General rights

It is not permitted to download or to forward/distribute the text or part of it without the consent of the author(s) and/or copyright holder(s), other than for strictly personal, individual use, unless the work is under an open content license (like Creative Commons).

#### Disclaimer/Complaints regulations

If you believe that digital publication of certain material infringes any of your rights or (privacy) interests, please let the Library know, stating your reasons. In case of a legitimate complaint, the Library will make the material inaccessible and/or remove it from the website. Please Ask the Library: <https://uba.uva.nl/en/contact>, or a letter to: Library of the University of Amsterdam, Secretariat, Singel 425, 1012 WP Amsterdam, The Netherlands. You will be contacted as soon as possible.

manual

REVISED EDITION 2001

# Applied Health Research

Anthropology of  
Health and Health Care

A.Hardon, P.Boonmongkon,  
P.Streefland, M.L.Tan, T.Hongvivatana,  
S.van der Geest, A.van Staa,  
C.Varkevisser, M.Chowdhury,  
A.Bhuiya, L.Sringeryuang,  
E.van Dongen, T.Gerrits

# APPLIED HEALTH RESEARCH MANUAL

This manual has been prepared for:

The International Course in Anthropology of Health and Health Care.

This is a joint initiative of:

- Mahidol University, Center for Health Policy Studies, Thailand
- University of the Philippines, National Institute of Health, The Philippines
- Royal Tropical Institute, Amsterdam, The Netherlands
- University of Amsterdam, Medical Anthropology Unit, The Netherlands
- BRAC, Bangladesh
- ICDRR, B, Centre for Health and Population Research, Bangladesh

# APPLIED HEALTH RESEARCH MANUAL

## ANTHROPOLOGY OF HEALTH AND HEALTH CARE

### AUTHORS

ANITA HARDON  
PIMPAWUN BOONMONGKON  
PIETER STREEFLAND  
MICHAEL LIM TAN  
THAVITONG HONGVIVATANA  
SJAAK VAN DER GEEST  
ANNELOES VAN STAA  
CORLIEN VARKEVISSER  
CECILIA ACUIN  
MUSHTAQUE CHOWDHURY  
ABBAS BHUIYA  
LUECHAI SRINGERUANG  
ELS VAN DONGEN  
TRUDIE GERRITS



HET SPINHUIS  
2001

ISBN 90 5589 191 6

Third, revised edition, 2001

First edition 1994

© 2001, the authors

No part of this publication may be reproduced or transmitted in any form or by any means, electronic or mechanical, including photocopy, recording, or any information storage and retrieval system, without permission of the copyright owner.

Cover design:        Jos Hendrix  
Lay-out:                Hanneke Kossen  
Printed and bound in the Netherlands

Het Spinhuis Publishers, Oudezijds Achterburgwal 185, 1012 DK Amsterdam, The Netherlands

# TABLE OF CONTENTS

Preface	vii
Acknowledgements	viii
Introduction	ix
Module 1	The Anthropological Approach 1
Module 2	Health and Illness 9
Module 3	Theoretical Perspectives in Medical Anthropology 17
Module 4	Health Systems 25
Module 5	Health Seeking Behaviour and Utilization of Health Services 33
Module 6	Self-Care 41
Module 7	Community Health Financing 47
Module 8	Community Participation and Primary Health Care 53
Module 9	Acceptance of Vaccination and Sustainability of Vaccination Programmes 63
Module 10	Reproductive Health 69
Module 11	Fertility Behaviour: A Micro Approach 75
Module 12	Adolescent Sexuality 81
Module 13	HIV/AIDS: Transmission and Prevention 85
Module 14	Coping with Chronic Ill Health 91
Module 15	Part I: Use and Distribution of Pharmaceuticals 97 Part II: Case Studies 103
Module 16	Growing Old in Cultural Perspective 107
Module 17	Childhood Illnesses: Diarrhoeal Diseases and ARI 113
Module 17a	Diarrhoeal Diseases: Transmission, Management and Prevention 115
Module 17b	Acute Respiratory Infections in Children 121
Module 18	Food, Health and Culture 125
Module 19	Hygiene, Water and Sanitation 131
Module 20	Culture and Mental Health 137
Module 21	Introduction to Applied Health Research 143
Module 22	Analysis and Statement of the Problem: Definition of Research Questions 153
Module 23	Literature Review 165
Module 24	Study Types and Designs 175
Module 25	Research Themes, Variables and Validity 191
Module 26	Overview of Data Collection Techniques 205
Module 27	Ethnographic Techniques 223
Module 28	Focus Group Discussions 235
Module 29	Design of Interview Schedules and Questionnaires 245
Module 30	Sampling 263

Module 31	Ethical Considerations in Applied Health Research	279
Module 32	Plan for Data Collection	287
Module 33	Pretesting	299
Module 34	Fieldwork Exercise	307
Module 35	Plan for Data Processing and Analysis	315
Module 36	Analysis of Qualitative Data	333
Module 37	Computer-Assisted Qualitative Data Analysis	347
Module 38	Analysis of Quantitative Data	353
Module 39	Work Plan	363
Module 40	Budget	371
Module 41	Finalizing and Reviewing The Research Proposal	381



## PREFACE

This manual contains the training modules of the *International Course in Anthropology of Health and Health Care* which has been held in Bangkok, The Philippines and Bangladesh. The purpose of this course is to acquaint the participants with the conceptual and methodological tools of Medical Anthropology. The course takes a multi-disciplinary approach and focuses on a number of important problem areas and issues including vaccination, reproductive health and AIDS, equity and community health financing, self-care and the use and distribution of pharmaceuticals.

In this third revised edition several new modules are added, and other modules are revised and updated. The first twenty modules, and Modules 23, 27, 33 and 40, have been developed specifically for this manual.

The beginning of each module lists a selection of relevant literature. Students are expected to read the literature before attending a session. The literature, the lectures and the exercises are designed to give the participants a good introduction into the Anthropology of Health and Health Care.

Modules 21 to 43 (except Modules 23, 27, 33 and 40) have been adapted from *Designing and Conducting Health Systems Research Projects, Health Systems Research Training Series, Volume 2*, a document published jointly by the Health Sciences Division of the International Development Research Centre (IDRC) and the Programme on Health Systems Research and Development of the World Health Organization (WHO) in 1991. The first author of this training series, Corlien Varkevisser, together with Anita Hardon, Pieter Streefland and Michael Tan, took prime responsibility for this revision. They bear responsibility for the adaptation which has entailed a change in focus towards anthropological and qualitative research in several modules.

## ACKNOWLEDGEMENTS

The authors of the manual on Anthropology of Health and Health Care are indebted to the International Development Research Centre and the Programme on Health Systems Research and Development of the World Health Organization for the kind permission to adapt their Health Systems Training Volume 2: Designing and Conducting Health Systems Research Projects for use in this course.

Modules 1 to 20, and Modules 23, 27, 33 and 40 were written and/or revised by a team consisting of Thavitong Hongvivatana, Pimpawun Boonmongkon, Michael Lim Tan, Pieter Streefland, Anita Hardon, Sjaak van der Geest, AnneLoes van Staa, Cecilia Acuin, Mushtaque Chowdhury, Abbas Bhuiya, Luechai Sringeriyuang, and Trudie Gerrits.

Trudie Gerrits has done the compilation and the organizational work of the third revised version, in close collaboration with Teresa Klerkx. Elizabeth Hayes has done the English editing of the revised third version, and Hanneke Kossen the lay-out.

The publication of the first edition of the manual and workbook was made possible by a grant from the European Community, Directorate-General for Development, Training and Cultural Cooperation. Support for this publication was provided by the Bill & Melinda Gates Children's Vaccine Program and Program for Appropriate Technology in Health (PATH). The views expressed by the authors do not necessarily reflect the views of PATH or the Bill & Melinda Gates Foundation. In addition we are also grateful for the financial support of the PPT-SM Fund of the University of Amsterdam.

# INTRODUCTION

There is increasing recognition that socio-economic and cultural factors are prime determinants of health and health care. What factors contribute to the acceptance of community health financing or a vaccination program? What are the needs of the growing group of elderly people or psychiatric patients? What social and cultural factors should be taken into account to operationalize all ambitious plans to improve reproductive health care? These are only some of the questions health professionals and health planners are confronted with. Anthropological research can be a tremendous support to health programmes, by giving insights in the perspective of recipients and providers of health programmes and health care, and also by providing managers and implementors of these programmes with mechanisms and strategies that could lead to a reorientation of health care programmes and policies towards the actual needs of the target group.

The need for training in anthropology of health and health care has been expressed by social scientists involved in multi-disciplinary health research projects, and public health staff at different levels, who are involved in providing health education and primary health care and who – in implementing the health programmes – are confronted with difficulties related to the socio-cultural context in which they work. It is for this reason that the International Course in Anthropology of Health and Health Care has been developed.

## For Whom the Course is Designed

The course has been designed for:

- research officers of public health institutes;
- coordinators of community health care programme (e.g. NGOs);
- project officers, responsible for the implementation of various health programmes (e.g. vaccination, water and sanitation, rational drug use and reproductive health care programmes);
- public health professionals;
- social science lecturers at universities;
- junior social scientists, who intend to specialize in Anthropology of Health and Health Care;

The course supports the trainees in their work by providing them with a better insight into the user-perspective of health and health care and by assisting them in the development of a research proposal that can contribute to the solution of specific problems encountered in their work.

## The Objectives of the Course

The specific objectives of the course are:

- to acquaint participants with anthropological concepts to be used in the analysis of health problems;
- to maximize knowledge and experience of methodological tools for applied anthropological research in the health field;
- to enhance participants' ability to formulate research questions and design research proposals in specific problem areas.

## The Contents of the Manual

The first twenty modules included in this manual give a general introduction to the anthropological approach to health and health care and to anthropological research on specific problems areas. Each module contains the references of specific literature to be read in preparation of the session, followed by the lecture notes, and an exercise. Modules twenty-one to forty-one then focus on the methodological tools for Applied Health Research. It is during this methodological section of the course that the participants further develop their own research proposals on priority health problems in their countries. For this purpose specific assignments have been developed.

## The Teaching Staff

The training course combines the skills and experience of six institutions: The Center for Health Policy Studies of the Mahidol University in Nakorn Pathom (Thailand), the National Institute of Health of the University of The Philippines (The Philippines), the Medical Anthropology Unit of the University of Amsterdam, the Royal Tropical Institute (KIT) in Amsterdam (The Netherlands), and BRAC and ICDDR,B in Bangladesh.

- The *Center for Health Policy Studies* (CHPS) is an independent research unit in the Faculty of Social Science and Humanities of Mahidol University, Thailand. It aims to promote and conduct health policy and health service research and evaluation, to form the basis for rational and evidence-based health policy formation and implementation. CHPS also provides short course training on Medical Anthropology, Qualitative Research Methodology and the Promotion of Rational Drug Use. Its activities include organizing advocacy meetings at national and international levels. Major areas of research are Primary Health Care and health promotion, alternative medicine, anthropology of pharmacy, women's and reproductive health, HIV/AIDS, and research methodology.
- The *National Institute of Health* (NIH) of the University of the Philippines in Manila was established in 1997 as the university's research arm for the health sciences. The NIH aims to promote the conduct of health research and the utilization of research findings. The cluster on Health Social Studies seeks to determine the sociological

and humanistic factors affecting health through holistic, integrative and trans-disciplinary studies while promoting community empowerment. The NIH staff has contributed to the development of policies and programs of the Department of Health (DOH), including its Reproductive Health, Women's Health, Immunization and Child Health Programs. Among the institute's current research involvements is the DOH's health sector reform initiatives.

- The *Medical Anthropology Unit* of the University of Amsterdam is one of the leading research groups in the field of Anthropology of Health and Health Care in Europe. It organizes an annual three-month course on Medical Anthropology for Dutch students. The experience gained by this course has been crucial to the development of the International Course in Anthropology of Health and Health Care. The unit also coordinates several multi-country studies on social-cultural aspects of health care in developing countries for the World Health Organization and the INCO-DEV programme of the European Commission. In this endeavour the unit has been confronted with the need to train researchers in the field of Anthropology of Health and Health Care.
- The *Royal Tropical Institute* (KIT), Amsterdam, aims to improve the health status of people in low- and middle-income countries by supporting the development of effective, equitable and sustainable health systems. It also provides education and training to health professionals.
- *BRAC*, established as a small relief organization in Bangladesh in 1972, has evolved as the largest non-governmental organization in the world. BRAC works with people whose lives are dominated by extreme poverty, illiteracy, diseases, and other handicaps. With its countrywide development interventions, BRAC strives to bring about positive change in the quality of life of these people. BRAC's major interventions include rural and urban development, primary education, and health. A comprehensive package of services is delivered through community-based outreach centres. The support programmes include training, research, monitoring, publications, communications, infrastructure development, and some income generating enterprises.
- *ICDDR,B*, the Centre for Health and Population Research is a non-profit international health research organization with headquarters in Dhaka, Bangladesh. It conducts multi-disciplinary research including social and behavioural issues and provides service and training in a variety of the most important health problems, which the developing countries face. Initially focused on cholera and diarrhoeal diseases, the mandate of the Centre has broadened considerably, and the Centre is a world leader in studies of and solutions for common conditions prevalent in the developing nations and associated with poverty, including infectious diseases, malnutrition, high fertility, microbial and chemical contamination of the environment and need for better health services.



**MODULE 1**

**THE ANTHROPOLOGICAL APPROACH**

# THE ANTHROPOLOGICAL APPROACH

## Objectives

At the end of this Module, the participants should:

- have gained insight into the main concepts of cultural anthropology;
- be able to explain how the anthropological approach differs from the natural science approach;
- have gained an understanding of the general objectives and approaches of medical anthropology.

## Literature

Foster, G.M. & B.G. Anderson

- 1998 'The New Field of Medical Anthropology.' In: S. Van der Geest & A. Rienks (eds), *The Art of Medical Anthropology. Readings*. Amsterdam: Het Spinhuis, pp. 3-9 (**recommended**).

Helman, C.G.

- 2000 *Culture, Health and Illness*. London: Wright, pp. 1-12 (**recommended**).

Nanda, S. & R.L. Warms

- 1998 *Cultural Anthropology*. Belmont CA: West/Wadsworth Publishing Co., pp. 1-17; 38-58.

## Contents

- 1 What is Culture?
- 2 The Anthropological Approach: Contextualization
- 3 The Emic and Etic Approaches
- 4 Cultural Relativism and Respect for the 'Other'
- 5 Medical Anthropology



## What is Culture?

Culture is the basic concept of cultural anthropology, but what is it? Culture is so close to us and taken so much for granted – it seems to be so ‘natural’ – that we find it difficult to define. Culture is for the human being what water is for a fish.

More than a hundred attempts have been made by anthropologists to define culture. One early, well-known definition comes from Tylor (1871):

*‘That complex whole which includes knowledge, belief, art, morals, law, custom, and any other capabilities and habits acquired by man as a member of society.’*

Another anthropologist, Herskovits (1955), produced a very concise and general definition: ‘The man-made part of the environment’. He placed everything produced by human beings into the domain of culture. This included ideas, values, rules, customs and other non-material human achievements, as well as material artefacts such as tools, houses, means of transport, art, food items and pharmaceuticals. Emphasis on either material or non-material aspects of culture depends very much on the researcher’s theoretical perspective. One last example is Keesing’s definition (1981). Keesing regards culture as a set of ideas and rules:

*‘Cultures ... comprise systems of shared ideas, systems of concepts and rules and meanings that underlie and are expressed in the ways that humans live. Culture, so defined, refers to what humans learn, not what they do and make. As Goodenough (1961: 522) expressed it, this knowledge provides “standards for deciding what is, ... for deciding what can be, ... for deciding how one feels about it, ... for deciding what to do about it, ...”.’* (Keesing 1981: 68-9)

He uses the metaphor of culture as a pair of glasses through which we see the world in a particular way. Keesing’s emphasis on shared meanings is a concept essential to this course. Furthermore, anthropologists are not only interested in ideas, beliefs and meanings but also in what people do, as actual practices often reflect beliefs.

## 2 The Anthropological Approach: Contextualization

How do anthropologists approach their object of study? In many scientific disciplines, researchers try to *explain* their object by reducing it to some basic principle. Anthropologists have long tried to do the same thing. They hoped that they could explain why, for example, people have a certain belief or use a particular agricultural technique by tracing the history of its origin or by looking for regularities in human behaviour, which finally could lead to the discovery of underlying ‘social and cultural laws’ analogue to the laws formulated in the natural sciences.

These attempts have now largely been abandoned. Anthropologists have lowered their ambitions and now try to *understand* the meaning of people’s ideas and practices. One could still call this ‘explanation’, but it is very different from the explanation offered by the natural sciences.

The anthropological approach to gaining understanding of a certain subject is to study it in its context. In human language words derive their meaning from the sentence in which they are used, and the meaning of a sentence is also dependent on the sentences around it. In a similar way people's ideas and practices can only be understood when viewed in context. The anthropological approach is, therefore, often the opposite of what is practiced in natural sciences. The object of research is not 'dissected' or reduced to smaller entities, it is broadened by the inclusion of its relevant context. The biologist studies the quality of water by taking one drop and placing it under a microscope, looking for microbes. The anthropologist is likely to study how people use water in everyday life, who collects it, who uses it, for what purpose, etc. While describing the use and the importance of water for the community, the anthropologist writes an *ethnography*.

A favoured research technique in finding an answer to these questions is *participant observation*. Participant observation is the primary research method in ethnographic fieldwork. It involves living for an extended period among the group being studied. To get to know the people she or he is studying the anthropologist must, as far as possible, share her or his experiences and participate in daily events in order to be able to describe customs and beliefs 'from within' (cf. Nanda & Warms 1998:10-11). During this course anthropological field research techniques, including participant observation, will be both discussed and practiced (see Modules 27-29 and 36).

The anthropologist's favourite type of study is the *case study* which permits a more or less holistic description. While the biologist's workplace is the laboratory, anthropologists conduct their research in the community of people they study. Although these two approaches often seem to be in conflict, it would be more correct to see them as complementary. An example may be useful to show the complementary character of the anthropological and natural science approach:

*A nutritional survey in a community of Miskito Indians in Nicaragua revealed that their average caloric intake was about 45% below the levels recommended by the Food and Agricultural Organization (FAO) and their protein intake fell about 30% below the suggested FAO levels. This biomedical problem was taken up by the anthropologist Weiss who placed the food situation in its wider socio-economic and political context. His anthropological study showed that the Miskito Indians, in their attempts to join the cash economy, were selling their most wholesome food – green turtles – to a commercial company and using the money to buy other, less essential and less nutritional foods. Cooperation between nutritionists and anthropologists produces a deeper understanding of the problem and is likely to lead to more efficient measures to improve the situation (cf. Weiss 1980).*

### 3 The Emic and Etic Approaches

The anthropologists' emphasis on understanding and studying culture in context usually implies trying to discover how people view their own situation and how they solve their problems. This we call the *emic* approach. It can be contrasted with the *etic* approach, which is based on ideas that outsiders, policy-makers and health workers

included, have about a particular group. It has frequently been the case that development projects have failed because they do not take the community's own ideas and preferences into account. Anthropological research focusing on the emic point of view may help to correct this shortsightedness.

#### 4 Cultural Relativism and Respect for the 'Other'

When ideas and practices are studied within their context it is assumed that nothing has a fixed meaning. If the context changes, the meaning will also change. By studying and comparing different contexts, or in wider terms, different cultures, we are faced with the phenomenon of the versatility of meaning. Beliefs that seem self-evident and 'natural' in one culture may be regarded as bizarre in another. A Western-trained doctor may think that consulting an oracle to find out who caused a disease is useless and senseless, while his patient may be puzzled by the doctor's inability to pay attention to the deeper, underlying cause of the disease.

The anthropologist thus reaches two, somewhat contradictory, conclusions. In the first place, people tend to consider their way of thinking and acting as correct, as 'natural', and take their own cultural solutions for granted. On the other hand, by pointing out this tendency and by comparing different cultures, the anthropologist makes clear that people's ideas and actions have little to do with 'nature'. Rather they are the products of their cultural environment. In the light of the extreme cultural diversity of ideas and practices to be found in the world it is clear that one cannot speak in universal terms. Anthropologists show that life can be lived in different ways and that it would be misleading and ethnocentric to call one way the correct way. *Ethnocentrism* means viewing other peoples and ways of life in terms of one's own cultural assumptions, customs and values. Instead, anthropologists call for respect between cultures based on a relativistic view of culture. *Cultural relativism* is a basic assumption within cultural anthropology. Since cultures are diverse and unique, they can only be understood in terms of their own standards and values. Cultural relativism does not imply, however, that all cultures, in all respects, are equal in value (cf. Nanda & Warms 1998:10).

#### 5 Medical Anthropology

In medical anthropology the approach and concepts described above are applied to the study of people's ideas and practices concerning health and illness (see Module 2). In all human societies beliefs and practices relating to ill-health are a central feature of cultural life.

Although cultural beliefs and practices strongly influence people's health, culture is by no means the only factor involved. Personal, educational and socio-economic factors all may influence illness and health. Moreover, culture is always heterogenous and is never static. While medical anthropologists stress the importance of culture, they are also wary to avoid cultural stereotypes and victim-blaming – that is, seeing the poor health of a population solely as the result of their culture. Stereotypes are negative attributions, often based upon dubious assumptions about a certain cultural group.

MEDICAL ANTHROPOLOGY can be briefly defined as the study of medical phenomena as culture. 'Medical phenomena' refers to anything concerning human health. It is possible to distinguish two broad categories of medical phenomena: illness and the response to illness (health care). 'Culture' refers to the man-made environment, emphasizing the world of shared ideas and rules.

---

*In many cultures mothers hold specific cultural beliefs about the causes of diarrhoea. These beliefs are often dismissed as 'superstitious' by health professionals who believe that people's 'ignorance' is responsible for high mortality among young children. Here we see an example of cultural stereotyping which leads to victim-blaming. More commonly, high mortality rates should be attributed to socio-economic factors such as poverty or the inaccessibility of health services. An anthropologist would not call such maternal beliefs 'ignorant' or 'superstitious' but rather would consider them examples of 'indigenous knowledge'.*

The adjective 'medical' in medical anthropology may be confusing and lead some to believe that it is especially concerned with biomedicine. It should be clear by now that medical anthropology belongs to the domain of cultural anthropology. It has a distinctly different research approach than that of the biomedical sciences. However, it may be useful to distinguish between two ideal types of medical anthropology. Anthropology *in* medicine refers to the work of anthropologists carried out in close collaboration with medical professionals, making their data available to doctors in order to improve the quality of medical services.

*By explaining patients' and doctors' ideas about illness, anthropologists may contribute to better communication between doctors and patients and to a more adequate diagnosis being reached. Another example would be research into cultural and social factors that influence patients' adherence to the therapeutic regimen as prescribed by the doctor with the aim of improving compliance.*

In the anthropology *of* medicine approach, anthropologists take a distance from medical practice and study it as a social and cultural phenomenon. They may, for example, investigate how unequal power relations are played out and reproduced in the doctor-patient or doctor-nurse interaction. They also may describe the treatment of patients in a hospital as a set of rituals.

*Another example of anthropology of medicine is the criticism of the term compliance itself for being doctor-centred (Conrad 1985). At first sight such studies may not seem very useful to medical practitioners – they may even irritate them – but in the longer term some doctors may also find these studies instructive and use them to improve their practice. This last example shows that there is no rigid distinction between anthropology in and of medicine.*

## Additional References

Conrad, P.

- 1985 'The Meaning of Medications: Another Look at Compliance.' *Social Science & Medicine* 20 (1): pp. 29-37.

Keessing, R.M.

- 1981 *Cultural Anthropology. A Contemporary Perspective*. New York: Holt, Rinehart & Winston.

Weiss, B.

- 1980 'Nutritional Adaptation and Cultural Maladaptation: An Evolutionary View.' In: N.W. Jerome et al. (eds), *Nutritional Anthropology. Contemporary Approaches to Diet and Culture*. Pleasantville: Redgrave, pp. 147-180.
- 

## Exercise

The participants are asked to discuss three questions with regard to the topics of their research proposal prepared at home:

- 1 To what extent is contextualization present in the proposal?
  - 2 Which emic and etic approaches can be found in the proposal?
  - 3 How anthropological is the proposal? Can the proposed research be categorized as anthropology *in* or *of* medicine? Explain why.
-



**MODULE 2**

**HEALTH AND ILLNESS**

## MODULE 2

# HEALTH AND ILLNESS

### Objectives

At the end of this Module, the participants should be acquainted with:

- the cultural perspective on health and illness;
- related concepts in medical anthropology such as explanatory models, disease, illness and sickness.

### Literature

Helman, C.G.

2000 *Culture, Health and Illness*. London: Wright, pp. 12-32 and 79-107.

### Contents

- 1 The Human Body
- 2 Illness and Health as Cultural Phenomena
- 3 Disease, Illness and Sickness
- 4 Medicalization
- 5 Explanatory Models
- 6 Classification of Theories of Illness Causation
- 7 Illness Prevention



## 1 The Human Body

The human body is more than just a physical organism. It is also the focus of a set of beliefs about its social and psychological significance, its inner structure (anatomy) and function (physiology). This set of beliefs is called the *body image* and is largely culturally determined. Information on social status, gender or occupation is expressed through the body and its adornments. Lay theories on the structure and functioning of the body influence the way people perceive ill-health. In *humoral medicine*, the healthy working of the body is thought to depend on a harmonious balance between two or more elements or forces within the body. This balance is dependent on external forces, such as diet, environment and supernatural agents as well as on internal influences such as an individual's constitution or state of mind. Special conditions such as pregnancy, and certain body fluids such as blood, may be seen as *multivocal symbols*: potent images expressing any number of meanings.

## 2 Illness and Health as Cultural Phenomena

In Module 1, medical anthropology was defined as the study of the social and cultural dimensions of health and health problems and people's attempts to solve them. There are at least four reasons to view *health problems* as cultural phenomena:

- a They often find their origin in people's *living and working conditions* (socio-economic status, gender position) and lifestyles (behaviours). Poverty is associated with many diseases. Women are particularly vulnerable due to both their reproductivity and their position in society. Lifestyles (such as smoking, an unbalanced diet, or intravenous drug use) and specific customs, dietary restrictions and other culturally determined health practices may also contribute to ill-health.
- b They are *communicated* to others in ways that are culturally prescribed. In one culture a sick person may be expected to show his pain, while in another she or he is expected to do the opposite. Again, a patient in one culture may seek the company of others, while in another cultural setting she or he suffers in isolation.
- c They are *explained and labelled* in accordance with existing, cultural concepts. Dominant cultural beliefs that provide illness explanations include hot/cold ideas, belief in spirits, fear of witchcraft or trust in natural science.
- d They are *experienced* in a way that has been influenced by prevailing cultural ideas. Whether an illness is regarded as serious or harmless can vary from one culture to another. Such ideas also affect how the patient experiences the illness episode.

If illness is a cultural phenomenon, *health* must be one as well. People in different cultures have different ideas about health. In Exercise 2 of this Module the culture-bound character of the concept of health will be demonstrated by comparing the concept in various cultures.

### 3 Disease, Illness and Sickness

Anthropologists often make analytical distinctions between disease, illness and sickness. This is done to stress the different perspectives of the various actors involved in the experience of illness and healing.

---

DISEASE is the definition of a health problem *by a medical expert*; ILLNESS refers to the experience of the problem *by the patient*; and SICKNESS is the social role attached to a health problem *by the society at large*.

---

*Disease* refers to the doctor's perspective on ill-health. This view is based on scientific rationality and assumes that diseases are universal in form, progress and content. This perspective does not include the social or psychological dimensions of disease, the context in which it appears, or its culturally defined meaning. It must be stressed that the doctor's perspective is also culture-bound and subjective. In various societies, and at different times, doctors maintain any number of ideas and standards on 'normal' blood pressure or on an 'abnormal' mental constitution. Anthropologists, on the contrary, do not believe in the universality of disease.

*Illness* reflects the patient's perspective (the emic approach). It is influenced by the cultural, social and emotional context in which it occurs and by an individual's background and personality. Illness may be present where disease is absent. A folk illness is a pattern of symptoms and signs which are recognizable to members of a particular culture. Their culture provides an etiology, a diagnosis, preventive measures and a regimen for healing this condition.

The term *sickness* refers to the influence of the society-at-large on illness and the individual suffering from ill health. Every culture has its own *language of distress*. For example in his research in Taiwan, Kleinman (1980) describes the process of somatization: *unpleasant emotional states and stress are expressed in the form of physical complaints. This implies that becoming ill is a social process involving others at all stages. Sick individuals are designated a different social role than the healthy: often they are exempted from work and other social responsibilities.*

Another example of how society affects thinking on ill-health is the fact that certain serious and life-threatening conditions such as cancer, tuberculosis (TB) and, more recently AIDS, have come to symbolize all that is thought to be 'unnatural' or morally wrong. Diseases thus become metaphors of evil (Sontag 1978). (See also Module 14.)

### 4 Medicalization

Socio-cultural norms may call someone ill because of a certain behaviour which may not be socially acceptable. The way in which Western societies increasingly label

socially unacceptable behaviour as sickness has been criticized as *medicalization* (Illich 1975). Medicalization refers to the process of labelling social and emotional phenomena as medical, which, by consequence, ask for medical intervention. Examples are addictive behaviour (excessive drinking, substance abuse or gambling), anxiety or deviant sexual behaviour. In addition, decisions about general issues such as employment, judicial matters, education and sports are often entrusted to medical professionals. Medicine has thus become a powerful factor of social control. One could say that in many societies medicine has replaced religion as the most important moral and political force.

## 5 Explanatory Models

Various actors involved in an individual's health problem are likely to have different ideas about the origin and character of the problem and about what should be done to solve it. Kleinman's concept of the *explanatory model* helps us to 'map out' and interpret these ideas.

---

EXPLANATORY MODELS are held by both patients and practitioners. They offer explanations for the origins of a condition and its treatment. Through explanatory models meaning is given to the symptoms.

---

Kleinman emphasizes that explanatory models need to be distinguished from *general* beliefs on illness and health care, since explanatory models are a response to a *particular* episode of illness. Consultations with a doctor are actually transactions between the lay and biomedical explanatory models of a particular illness. This interaction can only be fully understood in the context of the society as a whole, the physical setting of the consultation and the socio-economic conditions of the parties involved.

## 6 Classification of Theories of Illness Causation

Lay theories of illness causation have been widely studied in medical anthropology. Various classifications have been suggested. Young (1983) distinguishes *internalizing* and *externalizing* beliefs. In an internalizing view, as is the case in biomedicine, the origins of ill-health are mainly located within the individual: the responsibility for the illness falls either on the patient (incorrect behaviour), or as the result of personal vulnerability. Externalizing beliefs attribute the causes of an illness episode to the natural world (natural environment, climate, infections), to the social world (witchcraft, sorcery or the evil eye) or to the supernatural world (gods, spirits or ancestors). An externalizing perspective on illness is often expressed through a narrative account. The patient is able to tell a 'story' about the events which eventually led to her or his sickness.

Another classification of theories of illness causation has been proposed by Foster (1998). In *personalistic* theories, illness is attributed to the purposeful intervention of an

agent, either supernatural or human. In *naturalistic* theories, illness is explained in impersonal, systemic terms: it can be caused by natural forces or by imbalance within the individual, the view taken, for instance, in humoral medicine or by physiological processes, which is the view held in biomedicine.

## 7 Illness Prevention

Theories of illness causation open the way to illness prevention. If one knows who or what causes a disease, one also has ideas on how to prevent it. Where a particular agent, an evil person or deity, is held responsible, people can take measures to protect themselves against her or his actions or to temper her or his anger. Where a disease is explained by bacteriological concepts, preventive action concentrates on stopping dangerous organisms from entering the body by improved hygiene and sanitation. Vaccination has become another major strategy to prevent the spreading of disease.

Culture can be seen as one large preventive system: people follow the rules and wisdom of their culture to live as comfortably as possible and to avoid misfortune, including illness. In spite of its core position in medical thought and practice, and in culture at large, prevention has received only sparse attention from medical anthropologists. Like medical practitioners, they were more attracted to the dramatic events of illness than to the inconspicuous world of prevention. The current interest of anthropologists in ideas and practices around vaccination points to a gradual shift in the anthropological focus (Green 1999).

## Additional References

Foster, G.M.

- 1998 'Disease Etiologies in Non-Western Medical Systems.' In: S. van der Geest & A. Rienks (eds), *The Art of Medical Anthropology. Readings*. Amsterdam: Het Spinhuis, pp. 141-150.

Green, E.C.

- 1999 *Indigenous Theories of Contagious Disease*. Walnut Creek: Altamira Press / Sage.

Illich, I.

- 1975 *Medical Nemesis – The Expropriation of Health*. London: Marion Boyars.

Kleinman, A.

- 1980 *Patients and Healers in the Context of Culture*. Berkeley: University of California Press.

Sontag, S.

- 1978 *Illness as Metaphor*. New York: Vintage.

Young, A.

- 1983 'The Relevance of Traditional Medical Cultures to Modern Primary Health Care.' *Social Science & Medicine* 17 (16): 1205-1211.

---

## Homework Assignment

- 1 Describe five common local illness terms in your own society in 10 to 20 sentences. Try to classify them according to cause, symptoms, gravity, type of treatment and type of healer needed for this particular illness.

## Exercise

- 2 Make five different sentences in your own language in which you use the term which is closest to the English concept of 'health'.
  - 3 How would you describe the biomedical explanation of infectious diseases, using the classification developed (1) by Young and (2) by Foster & Anderson?
-



**MODULE 3**

**THEORETICAL PERSPECTIVES  
IN MEDICAL ANTHROPOLOGY**

## THEORETICAL PERSPECTIVES IN MEDICAL ANTHROPOLOGY

### Objectives

At the end of this Module, the participants should be able to:

- describe the main theoretical perspectives in cultural and medical anthropology;
- explain how theoretical perspectives influence the anthropological study of health and health care;
- outline their own theoretical ‘sympathies’ in their understanding of problems in the field of health and health care.

### Literature

Farmer, P.

- 1998 ‘Social Inequalities and Emerging Infectious Diseases.’ In: P.J. Brown (ed.), *Understanding and Applying Medical Anthropology*. Mountain View: Mayfield, pp. 98-107. (recommended).

McElroy, A. & P. Townsend

- 1998 ‘The Ecology of Health and Disease.’ In: S. van der Geest & A. Rienks (eds), *The Art of Medical Anthropology. Readings*. Amsterdam: Het Spinhuis, pp. 92-105. (recommended).

Peoples, J. & G. Bailey

- 1997 ‘The Development of Anthropological Thought.’ In: *Their Humanity: An Introduction to Cultural Anthropology*. Belmont Ca: West/Wadsworth, pp. 65-85. (recommended).

Scheper-Hughes, N. & M.M. Lock

- 1998 ‘The Mindful Body. A Prolegomenon to Future Work in Medical Anthropology.’ In: S. van der Geest & A. Rienks (eds), *The Art of Medical Anthropology. Readings*. Amsterdam: Het Spinhuis, pp. 347-368. (recommended).

Van der Geest, S.

- 1987 ‘Theoretical Orientations and Medical Anthropology.’ *Journal of Research and Education in Indian Medicine* 6 (3/4): 23-34.

Wellin, E.

- 1998 ‘Theoretical Orientations in Medical Anthropology. Continuity and Change over the Past Half-Century.’ In: S. van der Geest & A. Rienks (eds), *The Art of Medical Anthropology. Readings*. Amsterdam: Het Spinhuis, pp. 10-22. (recommended).



## Contents

- 1 Introduction
- 2 Structural Functionalism
- 3 The Ecological Perspective
- 4 The Political Economy Model
- 5 The Transactionalist Model
- 6 The Cognitive and Symbolic Approach
- 7 Critical Anthropology: A Synthesis

## 1 Introduction

For people trained in the biomedical tradition it is often difficult to understand why social scientists have such differing views on the same problem which often lead to fierce debates on theoretical perspectives. Yet biomedicine is no exception to the rule that within every scientific discipline different approaches and explanations exist side-by-side. For instance, the various biomedical sub-disciplines have very different views on the disease AIDS. While a virologist may emphasize the particularities of the virus and may stress that AIDS is a viral disease, in immunology the general idea is that AIDS results from a failure of the immune system. A pathologist develops theories of HIV-disease at the cellular level, while an epidemiologist is interested in the spread of the virus in large populations. The concept 'risk' means something completely different to a clinician than to an epidemiologist and, of course, a medical psychologist has yet another version of the 'truth'.

Within the general framework of the anthropological approach (contextualization, emic approach, relativism) there exists a wide variety of theoretical perspectives or, to put it another way, methods of studying and analyzing problems. These theoretical orientations affect the way the researcher views her or his research subject and which aspects she or he wishes to focus on. We have selected six theoretical orientations which we believe are of particular importance to medical anthropology.

## 2 Structural Functionalism

Structural functionalism was the dominant anthropological theoretical perspective between 1920 and 1960, but would seem to have been largely abandoned by anthropologists today. This is true only in a formal sense. Its basic tenets are still very much alive and are even considered as self-evident in anthropology: social and cultural phenomena are seen as *functionally interconnected* and basic to the structural maintenance of society. The anthropologist's task is to show how the different elements interact to make society into what it is. An often used metaphor of this perspective is the human body whose various organs and limbs have differing functions which contribute to the overall functioning of the body. Society then is seen as a system in equilibrium, just as the human body. One failing of the structural functionalist perspective is its inability to explain conflict and change within a society.

This model was also applied to the field of medical anthropology. Illness in this view is a dysfunctioning of the body and health care contributes to the *maintenance of society* as a whole by 'repairing' the sick individual.

## 3 The Ecological Perspective

Ecologically-oriented anthropologists view culture as *human adaptation to environment*. Cultural phenomena are seen first and foremost as human solutions to problems posed by the natural environment (climate, land and water resources, altitude, etc.). By view-

ing culture as a continuing adaptation to both nature and culture we are better able to grasp cultural change. Culture becomes then a dynamic concept.

In the ecological model health is regarded as the result of successful adaptation to environmental challenge and disease the outcome of the failure to adapt. Medicine, both curative and preventive, is seen here as a cultural device to restore optimal adaptation (cf. McElroy & Townsend 1998).

*The spread of malaria has been fruitfully studied using the ecological point of view. The beginning of agriculture in Africa about 2,000 years ago changed the ecology considerably. People started to clear the forest thus giving mosquitoes more chance to breed. Moreover, an agricultural way of life made it possible for more people to live together in one community which encouraged the spread of mosquitoes as well. The adaptation of the population to a new mode of life led to ecological change and the spread of malaria. Another example of the ecological approach in anthropology was given in Module 1 (Weiss' nutritional study of the Nicaraguan Miskito Indians).*

#### 4 The Political Economy Model

Other researchers, drawing their inspiration from the work of Marx, view culture mainly as the outcome of *political and economic* circumstances. Health – or the lack of it – and the quality of health care are largely determined by social competition between groups of people (classes) and the unequal distribution of scarce resources. Problems in the field of health and health care in developing countries are often linked to social and economic inequality and poverty which are often seen as the consequence of the penetration of the capitalist economy.

*Paul Farmer, who is both an anthropologist and a practicing physician, has done research on the social and political dimensions of AIDS in Haiti. In various publications he has emphasised that the spread of infectious diseases such as TB, Ebola disease and HIV/AIDS cannot be properly understood unless we place them in their 'political ecology'. The role of the World Bank, the national government, local authorities and the unequal control over resources account for the course of diseases. These factors dictate to a large extent people's living conditions and their access to effective health care (Farmer 1998).*

*A common topic studied from a politico-economic perspective is the sale of pharmaceuticals in developing countries. Pharmaceuticals are typically commodities representing a capitalist mode of production. The primary objective of their distribution is the accumulation of capital rather than the prevention or alleviation of disease. It is this profit motive which explains why some essential drugs are extremely scarce in a particular society while other, useless and perhaps even harmful, medicines may be dumped there in abundance.*

## 5 The Transactionalist Model

In the transactionalist perspective, culture is also seen as the *outcome of competition*, but in this case at a more individual level. In their attempts to reap maximum profit, enterprising individuals negotiate, become brokers, do ‘business’ and, in doing so, re-create and change society, including conditions of health and health care. This perspective can be applied to both health workers and their clients. The activities of health workers may be motivated by profit-making considerations and patients may use health services to further their individual interests.

*An example of a transactionalist approach is found in Golomb’s (1986) study of Thai Buddhist monk-practitioners. The author describes the practices of these monks as attempts to attract clients both for financial gain and social prestige. Without taking into account the functioning of this self-interest we are not able to comprehend the monks’ curing practices. Here medicine becomes a tool in people’s striving for social recognition.*

## 6 The Cognitive and Symbolic Approach

Other anthropologists emphasize the importance of the *cognitive and symbolic* aspects of culture, as we have seen in the first Module. This view has proved to be particularly useful and productive in medical anthropology. Questions such as: what is illness, how do people explain and label illness, how do they choose between various curative alternatives, and how do they communicate with health practitioners may be usefully addressed from a cognitive/symbolic point of view.

*An outstanding example of a cognitive and symbolic approach in medical anthropology is the work of Emiko Ohnuki-Tierney (1981) who studied illness and healing among the Ainu on the Japanese island of Hokkaido. The author is not so much interested in an individual’s behaviour as much as the ‘perceptual structure underlying behavior, verbal and nonverbal’ (1981: 11). She shows, for example, that the Ainu’s basic classification of the world in land and water is reflected in their classification of illness. They divide physical disorders into ‘dry’ and ‘wet’ conditions and associate specific illnesses with specific animals which live on the land or in the water. That association provides again the clue as to what treatment should be applied. A so-called ‘dog’-headache, for example, is treated by a medicine made from a part of a dog’s body. This cognitive-symbolic perspective vividly demonstrates the anthropologist’s interest in the emic approach.*

## 7 Critical Anthropology: A Synthesis

Having presented five influential theoretical perspectives in cultural (and medical) anthropology, we hasten to emphasize that these views are not mutually exclusive. On the contrary, they draw upon each other’s achievements and should be seen as comple-

mentary. This is illustrated in *critical anthropology* which has integrated the politico-economic and cognitive/symbolic views and tries to connect macro and micro level insights in social processes.

*In their seminal article 'The Mindful Body' Scheper-Hughes and Lock (1998) present illness as the 'embodiment' of society's most basic problems and conflicts. They distinguish three levels of analysis which they call 'bodies' to expound their perspective on the individual, the social and political dimension of human existence. Through the concept of 'individual body' they point out the lived experience of the individual. All human experiences, illness in particular, pass through the body. The 'social body' is their second level of analysis. Every interaction and communication is mediated, one way or the other, through the body. The third level of analysis, the 'body politic' refers to the fact that it is again through the body that people are subjected to control. The body, therefore, healthy or sick, reveals the intertwining of personal emotion, society and political power. Health and illness are 'natural', social and political phenomena.*

In this course all perspectives will be dealt with but the politico-economic and cognitive/symbolic perspectives – and their merging in critical anthropology – will receive the most attention.

### Additional References

Golomb, L.

1986 'Rivalry and Diversity Among Thai Curer-Magicians.' *Social Science & Medicine* 22 (6): 691-697.

Ohnuki-Tierney, E.

1981 *Illness and Healing Among the Sakhalin Ainu. A Symbolic Interpretation.* Cambridge: Cambridge University Press.

### Exercise

- 1 What theoretical perspective(s) does Helman (2000: 32-49) use in his chapter on diet and nutrition?
  - 2 Theoretical perspectives influence the researcher's interpretation of illness. In a case in Helman (2000: 227), Alland describes parasitic disease from a mainly ecological perspective. From what other theoretical perspective could this disease be considered?
  - 3 What – perhaps tacit – theoretical perspectives are present in the participants' proposals prepared at home? One of the course teachers will interview participants on their presuppositions regarding culture and society contained in their proposals. The participants will be invited to comment on the interviews.
-

**MODULE 4**

**HEALTH SYSTEMS**

# HEALTH SYSTEMS

## Objectives

At the end of this Module, the participants should be able to:

- apply the concept of cultural system to health care;
- describe the concept of medical pluralism;
- describe the interaction between the biomedical and local health systems.

## Literature

Helman, C.G.

2000 *Culture, Health and Illness*. London: Wright, pp. 50-78.

Pillsbury, B.

1982 'Policy and Evaluation Perspectives on Traditional Health Practitioners in National Health Systems.' *Social Science & Medicine* 16: 1825-1834 (recommended).

Van der Geest, S. et al.

1990 'Primary Health Care in a Multi-Level Perspective: Towards a Research Agenda'. *Social Science & Medicine* 30 (9): 1025-1034 (recommended).

## Contents

- 1 Health System as Part of a Cultural System
- 2 Medical Pluralism
- 3 The Multi-Level Perspective
- 4 The Popular, Folk and Professional Sectors
- 5 Other Classifications of Health Systems
- 6 The Relationship between Traditional and Biomedical Healers



## 1 Health System as Part of a Cultural System

A *cultural system* is a coherent whole of beliefs, norms, arrangements and institutions, and patterns of interaction. Anthropologists use the term ‘system’ also to refer to a cultural sub-field, e.g. religious system, economic system, and kinship system. In the same vein, the sum total of ideas and practices around health may be called a ‘health system’.

---

A HEALTH SYSTEM includes, in Kleinman’s words, “ ... patterns of belief about the causes of illness, norms governing choice and evaluation of treatment, socially-legitimated statuses, roles, power relationships, interaction settings, and institutions” (1980: 24).

---

It should be stressed that a health system is not a static phenomenon. It is in a continuous process of change due to pressures from both outside the system and from within.

## 2 Medical Pluralism

Every society has – to one degree or another – a multiplicity of health systems, a situation which we may term *medical pluralism*. Medical pluralism is usually related to the presence of different cultural or ethnic groups within one society, each adhering to its own medical tradition. But medical pluralism can also be the result of the introduction and acceptance of a foreign tradition in a culture (cf. Lee 1998). The presence of the bio-medical tradition in societies outside the ‘Western’ world is a case in point. Medical pluralism increases the range of therapeutic choice and thus complicates health-seeking behaviour, a topic which will be discussed more extensively in Module 5.

No health system is a water-tight entity. When various systems come into contact they generally exert an influence on each other. For example, in recent years traditional healers in some parts of the world have incorporated Western pharmaceuticals into their healing practices. Alternatively, in Western Europe some bio-medical doctors have started using acupuncture techniques. In addition, there is nearly always a hierarchical order between the various medical traditions based on power and prestige. This is likely to result in stronger systems imposing themselves on weaker ones or repressing them all together. In many countries, the biomedical health system has become the official system with other indigenous medical traditions being dismissed as mere quackery.

## 3 The Multi-Level Perspective

Within a health system one may distinguish *various levels of organization*. Starting from the household as the lowest level at which people organize their ideas and activities to maintain or restore health, one may move to higher levels such as the local community, the district, the region, the national level and finally the international level. Political power and economic resources to improve health are extremely unevenly distributed

over the various levels. In biomedicine, all these various levels are well developed. Within another health system, for example a local traditional one, this may be much less the case. Comparing what is being thought and done at these various levels of biomedicine can be very useful for understanding how this health system works (cf. Van der Geest et al. 1990).

The concept of different levels within a health system is also useful to research internal contradictions in health-care delivery. Often a tension exists between national policy and local practice. For example, Sciortino (1992) found in Indonesia that the nurses in the *puskesmas* (the village health centre) are mainly occupied with curative tasks and functions, while according to the official national policy they are supposed to perform mainly preventive health care tasks at community level. The actual role of the nurses in Indonesia is more in agreement with the expectations of the community than with the demands of national and international policy on primary health care.

#### 4 The Popular, Folk and Professional Sectors

Another way of ordering the variety of medical ideas and practices within one culture is to distinguish various, partly overlapping, *sectors in health care*. Kleinman (1980) introduced the concept of the popular, folk, and professional sectors (see Helman 2000: 51-62; see also figure 4.1 below). Explanatory models (see Module 2) are likely to differ markedly between the three sectors. What is extraordinary about Kleinman’s model is the emphasis he places on cognitive processes such as belief systems on health and illness.

**Figure 4.1** The Three Sectors of a Health Care System (Source: Kleinman 1980: 50)

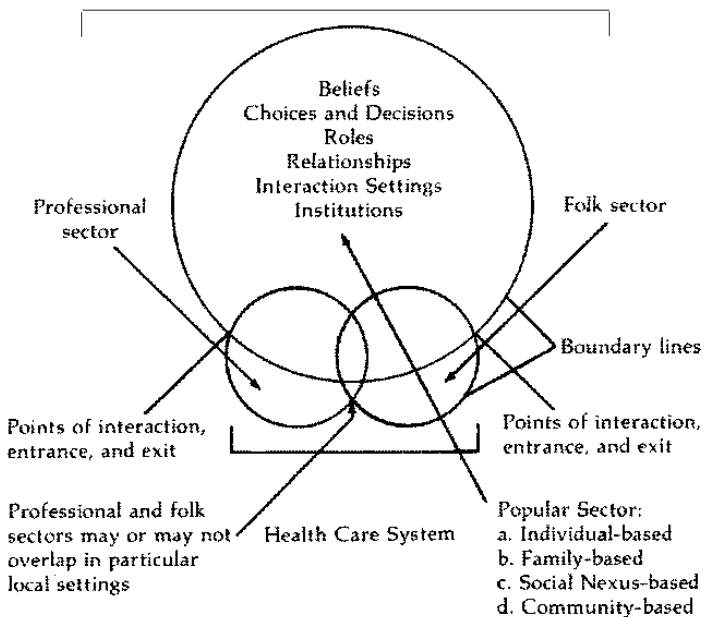

The *popular sector* comprises the lay, non-professional domain where illness is first recognized and treated. Self-care (see Module 6) takes place in this sector. It should be noted that various health care traditions are likely to be used in combination in the popular sector. The *folk sector* consists of local healers, such as herbalists, bone-setters, spiritual healers, diviners and traditional birth attendants. The *professional sector* is the domain of medical specialists who enjoy a privileged position in the sense that they are legally protected and control membership, knowledge and quality of medical practice by means of formally recognized professionalization. Those belonging to the professional sector include biomedical practitioners and paramedics as well as members of other professionalized health systems such as Ayurvedic, Yunani and Chinese medicine.

Across the popular, folk and professional sectors individuals have different – sometimes even conflicting – beliefs about the cause of illness and appropriate therapy.

*A child who passes many watery stools could be diagnosed by a health worker in a clinic as having acute diarrhoea. In the biomedical vision, this condition requires only the replacement of fluids through the administration of oral rehydration solution to the child (ORS) in order to prevent dehydration. The mother of the same child may, however, perceive the child's condition as 'natural', because the child is teething. Diarrhoea in this period is often not classified as an illness, but as an integral part of growing up. Yet a traditional healer such as a *molvis* in Pakistan (a Muslim religious healer) may classify the same case as *nazar* (evil eye disease) requiring specialist treatment with *taveez*: an amulet with texts of the Quran written on it. Another popular treatment in Pakistan for *nazar* is the 'egg cure': an unbroken egg is rotated around the victim's head and then thrown into the cooking fire (Mull & Mull 1988).*

Even when the same biomedical terms are used, beliefs about appropriate treatment can be different across the various sectors.

*The mother of a sick child may label the condition as fever. In some cultures, popular belief has it that young children with fever should be kept warm by wrapping them in blankets, since it is thought that cooling a 'hot' child is dangerous. This idea is diametrically opposed to the treatment of fever as preferred by most doctors. To reduce the risk of seizures caused by overheating, biomedically-trained personnel may advise washing the child in cold water and leaving the child uncovered. Here there is a clear difference between a popular and professional belief which has consequences for the treatment to be employed.*

## 5 Other Classifications of Health Systems

Several other distinctions have yet to be mentioned showing the cultural, social and political varieties within health systems. It may, for example, be useful to distinguish between *public and private medicine*, or *formal and informal medical practice*. Public medicine is offered by the state and is either inexpensive or free. Private medicine tends to be the domain of non-governmental organizations or private entrepreneurs. The

fact that private medicine has to be paid for affects its level of social appreciation and cultural appearance.

Informal medical practice is, strictly speaking, outside the realm of the law. It is usually carried out by people without a formal qualification and, for that reason, is a cause of concern among the medical profession. At the same time it should be stressed that informal medical practices are prevalent where the formal health services have failed. Informal practitioners are closer to the population and are, in some respects, more able to respond to people's daily problems, needs and demands than is the official health care system. Informal medical practices are mostly carried out in what Kleinman has called the popular sector of health care.

Another point to be stressed is that a health system is an integral part of the wider culture and society in which it is found. This means that ideas, practices, organizational arrangements, roles and statuses in the health system reflect the *wider socio-cultural and political-economic context* in which they occur and are influenced by that context. Religion, education, agriculture, type of government policy, communication and economic development are obvious components of this wider context. An example of a figure which tries to capture both the existence of various levels within a health system, different sections of health care and the wider context is provided by Hardon & Streefland (1993).

**Figure 4.2** Philippine Problem Analysis Diagram\*  
 (Source: Hardon & Streefland 1993: Appendix 1; Simplified)



\* This diagram has been prepared by the Community Drug Use programme (COMMED) in the Philippines.

## 6 The Relationship between Traditional and Biomedical Healers

The relationship between biomedicine and local traditions of health care needs special attention here. In most societies their relationship has long been rather hostile. In past decades we have witnessed some rapprochement and a growing mutual respect between representatives of these two systems. Some argue that local medical traditions have a unique and intrinsic value and advocate collaboration with local healers who have a better understanding of the problems in the community than biomedical practitioners who tend to be outsiders.

Pillsbury (1982) described some early attempts at cooperation between local healers and biomedical practitioners but came to the conclusion that genuine cooperation to any significant degree was extremely rare. The discussion of whether or not cooperation is desirable and feasible is an ongoing one. Some believe that the underlying theoretical concepts are so at odds that cooperation is practically impossible. Others have taken a more pragmatic view and have appealed for cooperation because of the mutual benefits involved. Another view is that a closer relationship between modern and traditional medicine may endanger the existence of the latter as it could be engulfed by modern medicine. A more general point emphasized by the majority of authors is that practitioners of the local and biomedical traditions should have more mutual understanding and respect for each other.

### Additional References

Hardon, A. & P. Streefland

- 1993 *Evaluating Effects of Rational Drug Use Interventions. A Research Note for the Collaborative Project on Community Drug Use.* Amsterdam: University of Amsterdam & Royal Tropical Institute.

Kleinman, A.

- 1980 *Patients and Healers in the Context of Culture.* Berkeley: University of California Press.

Lee, R.P.L.

- 1998 'Comparative Studies of Health Care Systems in Three Chinese Societies.' In: S. van der Geest & A. Rienks (eds), *The Art of Medical Anthropology. Readings.* Amsterdam: Het Spinhuis, pp. 165-182.

Mull, J.D. & D.S. Mull

- 1988 'Mothers' Diarrhoea Concepts in Rural Pakistan.' *Social Science & Medicine* 27 (1): 53-67.

Sciortino, R.

- 1992 *Care-takers of Cure: A Study of Health Centre Nurses in Rural Central Java.* PhD Thesis Free University. Amsterdam: Jolly.

## Assignment

- 1 Write down which different health systems, sectors, and levels of health care can be distinguished in your own society.

## Exercise

- 2 The film 'Bono Medicines' will be presented followed by a discussion about the following questions:
    - a What motives do the health workers in the hospital and the local healers have to seek collaboration?
    - b What do you think of the way the training of traditional healers is portrayed in the film?
    - c Is collaboration between traditional and biomedical practitioners desirable / possible?
    - d Is the training of traditional healers in biomedicine desirable / possible?
    - e Is the training of biomedical health workers in traditional medicine desirable / possible?
-

**HEALTH SEEKING BEHAVIOUR  
AND UTILIZATION OF HEALTH SERVICES**

# HEALTH SEEKING BEHAVIOUR AND UTILIZATION OF HEALTH SERVICES

## Objectives

At the end of this Module, the participants should be able:

- to view therapeutic decisions within their cultural and socio-political context;
- to discuss methodological problems in research on health seeking behaviour.

## Literature

Durkin-Longley, M.

1984 'Multiple Therapeutic Use in Urban Nepal.' *Social Science & Medicine*  
19 (8): 867-72.

Foster, G.M. & B.G. Anderson

1978 *Medical Anthropology*. New York: Wiley & Sons, pp. 243-253  
(recommended).

Kleinman, A.

1980 *Patients and Healers in the Context of Culture*. Berkeley: University of  
California Press, pp. 179-202.

## Contents

- 1 Health Seeking Behaviour
- 2 Patterns of Resort: Kleinman's Model
- 3 Initial Choice of Treatment: The Model of Young



## 1 Health Seeking Behaviour

Health seeking behaviour is probably the topic most studied in medical anthropology. In every contemporary society a wide variety of health care options exist, a situation we earlier referred to as medical pluralism. The strategies that people employ to decide which option to use at which stage of the illness are called *patterns of resort*.

Policy-makers and health workers have often been puzzled by people's seemingly 'irrational' decisions in their search for therapy. In the past, people in non-Western societies were often seen as passive followers of traditional cultural practices in health care and other behaviours. These cultural beliefs and practices were seen as constraints on the utilization of Western-style health services. In contrast, contemporary medical anthropologists use the concept of adaptation to focus attention on people as active, rational decision-makers who select *from* a range of alternative behaviours, depending on their knowledge, resources and other factors.

As Foster & Anderson (1978) point out, underuse of existing medical services is often not the result of indigenous *beliefs* or resistance to Western medicine, but is rather explained by the cost and availability of those services. People are remarkably pragmatic in testing and evaluating health care alternatives. The outcome of the individual decision-making process is to a large extent the result of a *cost-benefit analysis*: not only in economic but also in social terms. For the same reason curative medical services are often embraced more readily than preventive services. People are also very flexible in reconciling indigenous beliefs with modern Western treatment options such as pharmaceuticals. Western and traditional medicine are often seen not as competitive, but complementary.

Anthropologists have developed several models to study health seeking behaviour. There is a wide range in theoretical perspectives along the continuum between 'materialist/economic orientation' and 'cultural beliefs/symbolic patterns' views of behavioural causality (Young 1981). Some authors take accessibility of services as the main criterion for people's choices. Accessibility has to be understood in its geographical, economic and socio-cultural sense. Others try to correlate choice with qualities of patients (e.g. age, gender, education, ethnicity, access to new information), of practitioners (e.g. type of specialization), and the illness itself (e.g. natural versus supernatural causes; explanatory models).

## 2 Patterns of Resort: Kleinman's Model

Kleinman (1980) sees therapeutic choice as the outcome of a sequence of transactions. His study in Taiwan disclosed two major patterns in health seeking behaviour. Almost all episodes of illness were at first self-treated, often within the family network. If this did not produce symptomatic relief, people turned to family members, neighbours, pharmacists, or professional or folk practitioners. *Simultaneous resort* occurred when several treatment options were used at the same time, usually in the case of a serious childhood sickness.

*Hierarchical resort* occurred when different health care choices were made in sequence through the various sectors of health care, usually a chronic disorder or a recur-

rent sickness in an adult. Patterns of health seeking in Taiwan were thus associated with different types of illness problems. According to Kleinman, the type and severity of symptoms, the course of the illness and the labels and etiologies attached to it (explanatory models) play an important role in determining health care seeking behaviour, as do other relevant factors such as socio-economic status, age, sex, educational level, family role, urban or rural setting and the availability of services (see Figure 5.1).

The importance of explanatory models and disease etiologies in therapy choice has been demonstrated in many studies. For instance, the folk illness of the sunken fontanelle (*sutt; dosha; caida de la mollera*) is often not labeled as a serious complication of diarrhoea, but is seen as a specific childhood disorder that requires traditional therapy. Consequently, children suffering from this condition are not brought to a medical doctor but to a traditional birth attendant. This is an example of an *illness-specific* pattern of resort. Other research, for example Lane & Millar's (1987) study of the treatment of trachoma and other blinding eye diseases in an Egyptian village, stress that explanatory models are insufficient to explain therapeutic choice. In this study status differentials within the extended family, based upon gender and age as well as class differences, were the determinants of the various hierarchies of resort.

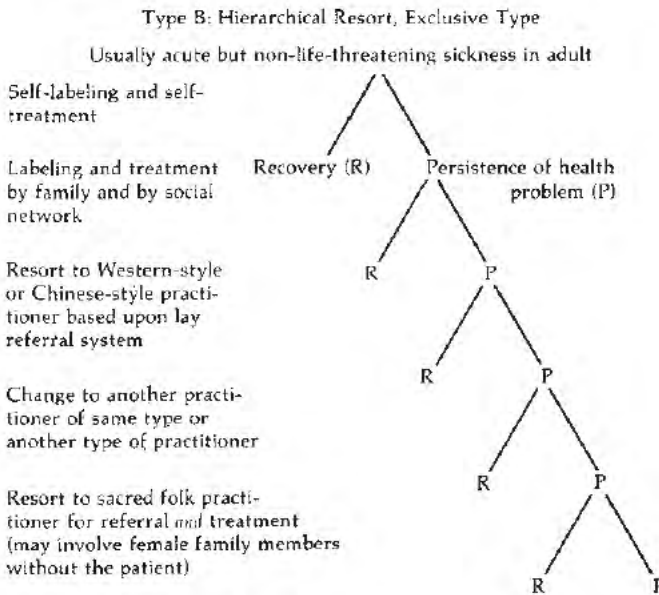
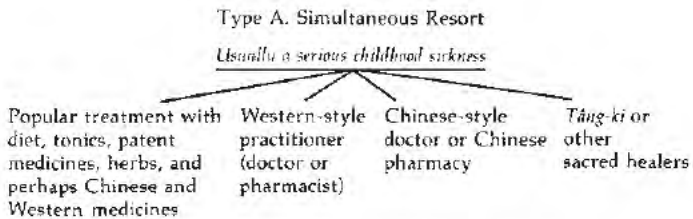

If no cure, resort to any of the above.

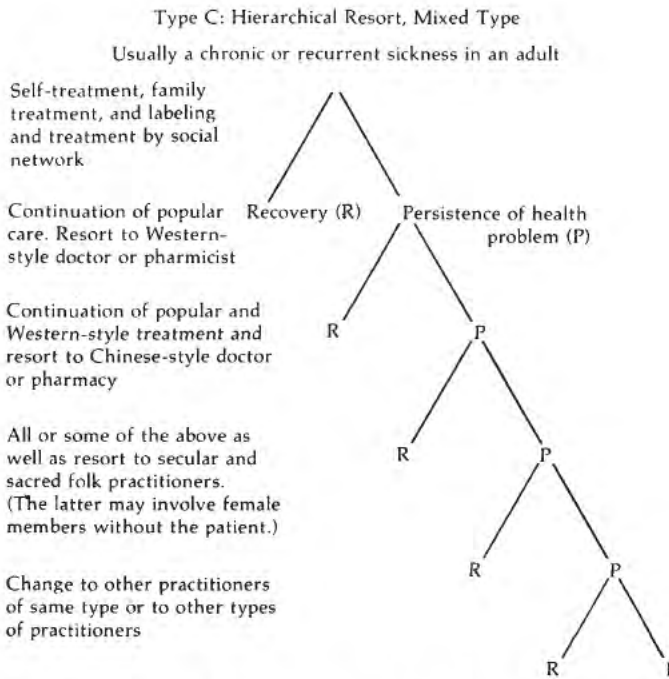

**Figure 5.1** Patterns of Health Seeking Behaviour: Simultaneous Resort and Hierarchical Resort (Source: Kleinman 1980: 188-189)

### 3 Initial Choice of Treatment: The Model of Young

In the past it was generally assumed that people would not utilize health services unless these were congruent with their cultural beliefs. It was generally thought that people would not utilize cosmopolitan medical treatment for illnesses believed to be caused by supernatural agents. However, recent research suggests that many people accept a very wide range of foreign medical interventions, especially injections and pills, even for illnesses such as *susto* and *evil eye* and other ‘culturally defined’ complaints (see Pelto et al. 1990). Rather than focusing chiefly on cultural definitions of illness and causation, many anthropologists have now turned their attention increasingly to the analysis of how people manage multiple, alternative health services in relation to their beliefs about the respective merits and shortcomings of the alternatives (Janzen 1978).

An example of the latter approach is Young’s research in rural Mexico (1981). He demonstrated that peoples’ perception of the gravity of the illness episode, their knowledge of the illness and its remedy, and the faith one has in the efficacy of the various therapies interacted with their assessment of the costs involved in the treatment. On the basis of interviews carried out using hypothetical cases, Young constructed a decision table for the initial choice of treatment:

**Figure 5.2** Decision Table for the Initial Choice of Treatment (Source: Young 1981: 116)

Rules	1	2	3	4	5	6	7	8	9
<i>Conditions</i>									
1 Gravity	1	1	1	2	2	2	3	3	3
2 Known home remedy	Y	N	N	Y	N				
3 'Faith'		F	M	(F)	F	M	F	M	(M)
4 Accessibility								N	Y
<i>Choices</i>									
a Self treatment	X			X					
b Curer		X			X		X		
c Practicante			X			X		X	
d Physician									X
<i>Key</i>									
Y = yes	1 Gravity		3 'Faith'			4 Accessibility			
N = No	1 = non serious		F = favours folk treatment			Y = money & transportation available			
	2 = moderately serious		M = favours medical treatment			N = either money or transportation not available			
	3 = grave								

The main anthropological contribution to the study of health seeking behaviour lies in *ethnography*. Anthropology's focus on the micro-level factors that affect household decision-making has led to the consideration of intra-cultural and intra-community factors (Pelto et al. 1990). These factors make behaviour intelligible by describing both the context in which people reach their decisions and by clarifying the rationality of these decisions. Anthropologists are reluctant to predict people's health seeking behaviour as health planners sometimes wish them to do. Their descriptions of the context and emic rationality of people's therapeutic choices may encourage health workers to adopt a more positive appreciation of people's low utilization of health services. Having more respect for patients' views will undoubtedly also improve the quality of their service.

## Additional References

Janzen, J.M.

1978 *The Quest for Therapy in Lower Zaire*. Berkeley and Los Angeles: University of California Press.

Lane, S.D. & M.I. Millar

1987 'The "Hierarchy of Resort" Re-Examined: Status and Class Differentials as Determinants of Therapy for Eye Disease in the Egyptian Delta.' *Urban Anthropology* 16 (2): 151-182.

Pelto, P.J., M.E. Bentley & G.H. Pelto

1990 'Applied Anthropological Research Methods: Diarrhoea Studies as an Example.' In: J. Coreil & J.D. Mull (eds), *Anthropology and Primary Health Care*. Boulder: Westview Press, pp. 253-277.

Young, J.C.

1981 *Medical Choice in a Mexican Village*. New Brunswick: Rutgers University Press.

---

## Homework Assignment

Read the following article carefully:

Durkin-Longley, M.

1984 'Multiple Therapeutic Use in Urban Nepal.' *Social Science & Medicine* 19 (8): 867-72.

Answer each of the following questions in *no more than 15 sentences*.

- a What is the main finding of Durkin-Longley's research in Nepal?
- b Which method is most suitable for researching a community's *actual* utilization patterns of health services:
  - a household-questionnaire asking questions about attitudes towards illness and health and specific illness-beliefs;
  - a household-questionnaire asking people about the way they treated the last episode of illness in their family.

Explain your answer.

- c Can you think of other methods to study utilization patterns of health services? Describe these.
- d What do you think of the quality of the data collection in the article of Durkin-Longley?
- e Durkin-Longley only discusses the position of health service consumers in the decision-making process. How do you think health care *providers* may influence the therapeutic decisions of consumers?

Give an example.

## Exercises

- 1 How can research into health seeking behaviour and utilization of health services be useful for health policy? Give an example.
  - 2 Look at Figure 5.1. and Figure 5.2. Discuss the predictive value of these health seeking behaviour models for a common illness such as acute respiratory infections in young children.
-



**MODULE 6**

**SELF-CARE**

# SELF-CARE

## Objectives

At the end of this Module, the participants should be able to:

- give a definition of self-care;
- understand non-compliance to a doctor's prescriptions from a user's perspective;
- describe the role of self-care in primary health care;
- point out in what way social science research may contribute to health policies and programmes that reduce medically unsafe self-care practices, while at the same time strengthening self-reliance.

## Literature

Abosede, O.A.

1984 'Self-Medication: An Important Aspect of Primary Health Care.' *Social Science & Medicine* 19 (7): 699-703.

Conrad, P.

1985 'The Meaning of Medications: Another Look at Compliance.' *Social Science & Medicine* 20 (1): 29-37.

Coreil, J. et al.

1993 'Social and psychological costs of preventive child health services in Haiti.' *Social Science & Medicine* 38 (2): 231-238. (recommended)

## Contents

- 1 The Importance of Self-Care
- 2 A User's Perspective on Self-Care



## 1 The Importance of Self-Care

Self-care is the most frequent response to illness. Self-care is a term that is difficult to define because of how readily it becomes intermingled with help from neighbours and treatment by lay specialists.

---

SELF-CARE has been defined as a process in which people function on their own behalf in health promotion and prevention, and in disease detection and treatment at the level of the primary health resource in the health care system (Levin 1981).

---

All activities undertaken by individuals to treat or prevent ill-health may be categorized as self-care. It encompasses individuals, for instance, male urban migrants, taking care of their own health, but also mothers caring for an entire family, and an unmarried daughter looking after her aged parents. As self-care is not limited to the individual but also includes members of one's own household, it is also referred to as home-care or family-care. In many cultures the family operates as a therapeutic group: it is a network for sharing knowledge and experience, making therapeutic decisions, and for sharing prescriptions and medicines. One important feature of self-care is autonomy: that a lay person (or persons) is able to function effectively on his/her (or their own) behalf in health decision-making.

Self-care constitutes, among other things, self-diagnosis and self-treatment. It may imply the use of home remedies, herbal medicines and modern pharmaceuticals (this is often referred to as self-medication) as well as dietary practices and the effects of religious and other taboos. In many parts of the non-Western world, the use of Western pharmaceuticals and body care products is becoming increasingly important in self-care.

Studies on the scope of self-care are hard to compare as they apply various definitions of self-care and include various methods. Yet, what the studies do have in common is that self-care is found to be the predominant form of health care. Estimates on the proportion of health care that is actually self-care, and which involved no professional intervention, range from 60% to 90% of all cases of illness.

*Hardon (1987) describes how the majority of childhood illnesses in a Filipino village are treated without consulting a doctor. In half of the cases Western pharmaceuticals are used. In her 1991 study of urban poor communities in metro Manila a similar pattern was found.*

## 2 A User's Perspective on Self-Care

Self-care is an issue of concern to health care providers, who particularly question the safety of self-medication practices. Health care providers tend to assume that they can determine what people may do themselves to improve their health and when they

should consult a professional. On the other hand, self-care could be defined as autonomy in matters of health and illness. It empowers people and is reflected in the organized efforts of people to participate together in finding solutions to mutual health problems, as is the case in self-help groups, patient mutual support associations, and consumer groups.

An increasing number of studies in developing countries have looked at self-care from a patient's perspective: why do people prefer certain therapies, what are their criteria for choice, and how do they evaluate the outcome of therapy. They cover use of biomedicine as well as indigenous forms of health care and traditional self-care practices. Many self-care studies are, at least partly, quantitative in nature, leading to conclusions on the scope of self-care and professional care, and on factors associated with these forms of care. These studies reveal, for instance, that people prefer to buy drugs in drugstores without consulting doctors because it is a convenient, effective, and efficient (cheap) way of treating common disorders.

*A study of antibiotic sales by pharmacies in Manila showed that almost 90% of customers purchased only 10 units of antibiotics or less (Lansang et al. 1990). The major reason for this was financial; but other reasons such as 'test the drug first' and 'check side effects first' suggest that practical considerations and efficacy testing also play an important role in the decision to buy a certain quantity of a drug.*

This example shows that even after consulting a doctor and receiving a valid prescription, a patient's freedom of choice regarding treatment strategy is not limited completely. The patient may decide to purchase only a small quantity of the prescribed drugs or not take the drugs at all. This practice is often referred to as *non-compliance* in the biomedical literature. The term compliance, i.e. the adherence of patients to the therapeutic regimen as prescribed by the doctor, has been criticized for being doctor-centred (Conrad 1985). From a patient's perspective, studies on non-compliance should look at the meaning of medications in people's everyday lives, looking also at reasons why people take their medications or why they do not. From this perspective the issue is more one of self-regulation than of non-compliance. What appears to be non-compliance from a medical perspective may in fact be a form of asserting control over one's disorder. Thus, self-regulation with prescribed medicine may also be regarded as a form of self-care. It is, however, a form of self-care which at a higher level of aggregation may have negative consequences because disease agents may become resistant when drugs are not used by many users according to a regimen. This is, for instance, one of the reasons that in tuberculosis cases treatment drugs have to be swallowed in the presence of the provider. The socio-cultural factors influencing self-medication and other medication patterns will be discussed in Module 15. It is, finally, important to mention that self-care involves much more than taking medicines: it ranges from taking food supplements to enhance one's immunity to following a regular schedule of jogging.

## Additional References

Hardon, A.P.

- 1986 'The Use of Modern Pharmaceuticals in a Filipino Village: Doctor's Prescriptions and Self-Medication.' *Social Science & Medicine* 25 (3): 277-292.
- 1991 *Confronting Ill-Health. Medicines, Self-Care and the Poor in Manila*. Quezon City: Health Action Information Network.

Lansang, M.A. et al.

- 1990 'Purchase of Antibiotics Without Prescription in Manila, The Philippines. Inappropriate Choices and Doses.' *Journal of Clinical Epidemiology* 43 (1): 61-67.

Larme, A.C.

- 1997 'Health Care Allocation and Selective Neglect in Rural Peru.' *Social Science & Medicine* 44 (11): 1711-1723.

## Exercise

Read the article:

Abosedo, O.A.

1984 'Self-Medication: An Important Aspect of Primary Health Care.' *Social Science & Medicine* 19 (7): 699-703.

Discuss the following questions together:

- 1 What does the author mean by the term self-medication?  
What do you think of his definition of self-medication?
  - 2 What are the major research questions that the author addresses in his article? Do you have any comments on his questions?
  - 3 What factors are, in the author's view, important determinants for self-medication. Draw a diagram to illustrate how the author sees the relationship between these factors and self-medication. Add factors to the diagram that in your view should be included.
  - 4 To what extent do results of the study help us understand why people resort to self-medication? Do you have any comments on these results? Would other more qualitative research methods have led to different insights into reasons for resorting to self-medication?
  - 5 What are the major conclusions of the study? Are these conclusions supported by facts?
-

**MODULE 7**

# **COMMUNITY HEALTH FINANCING**

# COMMUNITY HEALTH FINANCING

## Objectives

At the end of this Module, the participants should be able to:

- explain the main characteristics and background of community financing in health programmes;
- understand the importance of socio-cultural factors in paying for health care;
- formulate what role anthropological research can play in strengthening community financing endeavours in health programmes.

## Literature

Dave, P.

- 1991 'Community and Self-Financing in Voluntary Health Programmes in India.' *Health Policy and Planning* 6 (1): 20-31.

Noterman, J-P. et al.

- 1995 'A Prepayment Scheme for Hospital Care in the Masisi District in Zaire: A Critical Evaluation.' *Social Science & Medicine* 40 (7): 919-930.

## Contents

- 1 Introduction
- 2 The Importance of Equitable Health Care Financing
- 3 What is Community Financing?
- 4 Is Paying for Health Care Acceptable?
- 5 Community Financing and Accessibility

## Introduction

After most developing countries became independent, the health care services were extended and access to them was made free-of-charge. Accordingly in the 1950's, 1960's and part of the 1970's the emphasis was on building health care facilities and training all levels of health workers. With the arrival of Primary Health Care (see Module 8) emphasis on equitable access of health care led to increasing pressure on the health services whose quality often suffered. In the early 1990's developing countries' economies were negatively affected by a global economic crisis. International agencies providing support through Structural Adjustment Programmes (SAP) forced the governments of these countries to curtail public expenses which again was detrimental for the health services. To enhance sustainability and quality of health services in the 1990's international donors put it to the governments that their health care systems required reform, including the abolishment of free access. Since then, many countries have introduced some form of community financing.

## 2 The Importance of Equitable Health Care Financing

In all societies there are different forms of inequality. A major one is inequality in health, reflected by higher levels of morbidity and mortality among people whose standard of living is, in general, characterized by an inferior diet, bad housing and working conditions and little education. These people are, in other words, among the poor in society. Inequality can be observed and measured empirically. All government and NGO activities in the field of health care occur in this context of inequality and, subsequently, will have effects that reproduce these inequalities, enlarge them, or mitigate them.

---

Policies, activities and interventions that aim to mitigate or undo inequalities which are considered unfair and avoidable are equitable measures.

---

These equitable measures try to redress inequalities and are, as such, based on moral judgments about what is fair and what is unfair. In health care financing the equity issue is related to two questions: Is the user able to pay for the services? And: Does ability to pay affect access to the services? Equitable health care financing would imply that those who have the most, pay the most, either by way of progressive taxation or because they have to pay a fee for services, while those who are poor have to pay less or are even exempted. Equitable accessibility would mean that no matter whether and what is paid, or what social position one has in society, everybody has an equal chance to receive appropriate health care when needed.

### 3 What Is Community Financing?

Community financing is one of the options for the financing of health care. For a government that does not want to change its budgetary priorities it seems a good option when its resources are tight. It helps also to guarantee sustainability of a non-government health programme when recurrent costs are no longer covered by external funding.

There are various forms of community health financing. Direct fees for services (*user fees*) or for drugs (*revolving drug funds*) can be distinguished from several forms of collective *health insurance*. Each of these forms has its pros and cons and is more suited to some social and cultural conditions than others. Another important point is that community involvement may vary from contributing to a health care fund or paying for services, to managing the fund and deciding how the money is spent. Finally, it must be stressed that even when health care is formally free, there may be an informal fee system which regulates access to care in an effort to compensate for low salaries in the public sector. Killingworth (1999) et al. discuss such a system in Bangladesh.

The article by Dave (1991) describes and analyzes a wide range of community financing experiences in the non-governmental sector in India. There is a range of social mechanisms, such as reciprocity between neighbours, village cremation funds and rotating credit associations, which form a social basis for risk aversion and survival in difficult times. They lessen vulnerability and increase security. The prevalence of such social mechanisms in a specific social and cultural environment does not necessarily imply, however, that they may be an appropriate foundation or starting point for a new community financing initiative. The population concerned may, for instance, be too small or too mobile to constitute the collective membership base of a health insurance scheme. Another important point is often the lack of management skills required for the operation of a community financing scheme. The article by Noterman et al. (1995) describes the complexities of a prepayment scheme in Zaire.

In cases of prepayment schemes and health insurance funds it is important to recognize that there are some pivotal assumptions involved which must be met for them to succeed. First, the insurance scheme should cover a variety of health risks, so that the chance that all participants fall ill at the same moment – and subsequently need money at the same time – will be decreased. Second, participants need to be inclined to take care of others: the rich for the poor, the young for the old, the less ill for the often ill. By paying for the ill now, healthy persons assume that they will be cared for by others when they are old and more often ill. Third, people who participate in a prepayment scheme or health insurance fund are creating a public good. This is based on trust that participants will pay their due and continue to do so whenever they have drawn from the fund. This trust is enhanced considerably if a large institution, e.g. a bank or the state pledges a guarantee to safeguard the fund.

### 4 Is Paying for Health Care Acceptable?

More often than not, people are familiar with paying for health care as they already pay for the services of traditional healers and private practitioners of cosmopolitan medi-



cine although the forms of payment may vary considerably. Since higher financial costs make a product more valuable, paying for health may even contribute to the therapeutic effect. Nichter (1983) describes the market of health care as a competitive market in which the practitioner must win the trade of the lay population and the clients make their choice on the basis of cost-benefit calculations. When discussing variations in payment for services he describes how, in the South Indian context, villagers provide offerings to some traditional practitioners to establish a *moral bonding*. This mode of payment contrasts with the practice of adding a fee for services to the price of a medication which is common in transactions with cosmopolitan practitioners in the private sector. Even where the government sector is officially free, these services are often costly because they are time-consuming. Also, the unavailability of drugs means that people have to buy the prescribed medicines in the private sector. In the popular perception, 'free' services often equal poor quality.

## 5 Community Financing and Accessibility

One of the major concerns in community health financing is the *accessibility* of health services. The principle of equity requires equal access to health services for everyone. Shortage of cash or funds is often mentioned as the main reason why people do not consult the health centre where fees are charged. Access to drugs and to health care services will remain difficult for the very poor unless they receive financial assistance (often in the form of exemptions). Even though most people usually do find the money to pay for health services, these payments are often large in relation to their income. In Ghana, Waddington & Enyimayew (1989) found that payment is sometimes only made with the greatest difficulty, substituting for expenditures on food, agricultural development and education. Extensive community support mechanisms may provide a safety net in many cases, but there are also reports of poor peasants having to sell their small plot of land in order to afford basic health care (McPake et al. 1993). In community health financing initiatives, special attention should therefore be paid to marginalized groups who fall through the safety net and people who require extensive medical care, such as chronically ill patients or patients requiring hospitalization. In societies (e.g. in Sub-Saharan Africa) which are ravaged by HIV/AIDS or civil war or another war situation, both socio-economic fall-back mechanisms and people's asset base may have been destroyed or disintegrated which makes the above considerations even more serious.

## Additional References

Atim, C.

- 1999 'Social Movements and Health Insurance: A Critical Evaluation of Voluntary, Non-Profit Insurance Schemes with Case Studies from Ghana and Cameroon.' *Social Science & Medicine* 48:881-896.

Killingworth, J.R. et al.

- 1999 'Unofficial Fees in Bangladesh: Price, Equity and Institutional Issues.' *Health Policy and Planning* 14 (2): 152-163.

Nichter, M.A.

- 1983 'Paying for What Ails You: Socio-Cultural Issues Influencing the Ways and Means of Therapy Payment in South India.' *Social Science & Medicine* 17 (14): 957-965.

McPake, B. et al.

- 1993 'Community Financing of Health Care in Africa: An Evaluation of the Bamako Initiative.' *Social Science & Medicine* 36 (11): 1383-1395.

Waddington, C.J. & K.A. Enyimayew

- 1989 'A Price to Pay: The Impact of User Charges in Ashanti-Akim District.' *International Journal of Health Planning and Management* 4: 14-47.

## Exercise (choose two)

- 1 Discuss how local culture and social organization may affect the sustainability of the various forms of community financing mentioned in the Dave article. Are there minimal socio-cultural requirements to be met in each case?
- 2 Using Atim's article, discuss whether such voluntary non-profit insurance schemes would be feasible in your country. What could motivate rich people to participate in a health insurance scheme and share risks with the poor?
- 3 Vaccination programmes are usually free. One could argue that a public good, i.e. herd immunity, is created and that therefore as wide a participation as possible should be stimulated. On the other hand, asking a fee for a preventive intervention such as vaccination might enhance the sustainability of immunisation programmes in times when governments face financial problems. Do you think that parents would accept a vaccination fee? Give arguments for your answer and arguments that could convince parents.

**MODULE 8**

**COMMUNITY PARTICIPATION  
AND PRIMARY HEALTH CARE**

# COMMUNITY PARTICIPATION AND PRIMARY HEALTH CARE

## Objectives

At the end of this Module, the participants should be able to:

- understand the meaning of community participation from various perspectives;
- identify critical barriers in implementing community participation in health care programmes;
- use an analytical framework to assess community participation in health programmes.

## Literature

Rifkin, S.B., et al.

1988 'Primary Health Care: On Measuring Participation.' *Social Science & Medicine* 26(9): 931-940.

Stone, D.

1989 'Cultural Crossroads of Community Participation in Development: A Case from Nepal.' *Human Organization* 48(3): 206-213.

Zakus, J.D.L. & C.L. Lysack

1998 'Revisiting Community Participation.' *Health Policy and Planning* 13(1): 1-12.

## Contents

- 1 What is Community Participation
- 2 The Story of Primary Health Care
- 3 Problems in the Implementation of Community Participation in PHC
- 4 Measuring Community Participation

## 1 What is Community Participation?

---

COMMUNITY PARTICIPATION is a social process whereby specific groups with shared needs living in a defined geographic area actively pursue identification of their needs, take decisions and establish mechanisms to meet these needs (Rifkin et al. 1988).

---

An understanding of community participation is essential in medical anthropology for two main reasons: first, important behaviours related to health are influenced by the communities and social environments in which people live; and second, people actively change their environment in ways that affect not only their health but also that of their neighbours. These two factors may have positive and/or negative consequences at individual and community level.

Today community participation in health care exists in a wide range of contexts and scopes. People have organized themselves to lobby for building a health facility in their town, to oppose the setting up of a garbage dump or a nuclear reactor in their area, to protect traditional herbal resources, and even to protest against perceived abortifacient effects of tetanus toxoid vaccine. There are likewise many examples of people being organized to form brigades to build toilets and sewage systems, or to create neighbourhood watches against domestic violence incidents in their neighbourhood. It can be a strong collective force in improving lives. In this way, the study of community participation can be viewed as a study of political processes, requiring an understanding of concepts such as leadership, empowerment, social order and social control.

## 2 The Story of Primary Health Care

Primary health care (PHC) in its comprehensive form was envisioned as the ultimate expression of community participation in health. The four PHC principles – equity, appropriate technology, intersectoral action and community participation – represent a health development paradigm that looked beyond the curative/preventive biomedical framework and tried to address the underlying social causes of ill health which are poverty and injustice. Although meant as a global movement, the main arena for PHC was really the underdeveloped world.

---

COMMUNITY PARTICIPATION is the process by which individuals and families assume responsibility for their own health and welfare and for that of the community, and develop the capacity to contribute to their and the community's development. They come to know their own situation better and are motivated to solve their common problems. This enables them to become agents of their own development instead of passive beneficiaries of development aid (WHO 1978).

---

The story of primary health care begins in the mid 1900’s when most of the colonized world was given its ‘independence’. Many of these nations, eventually to be called ‘countries of the South’ (or underdeveloped or developing to distinguish them from their former colonial masters, the ‘countries of the North’ or the developed countries) began to draw up health programmes to provide health care patterned after those of their former rulers. Most of these plans ignored or paid little attention to the socio-economic and political base on which these programmes would operate. On paper, prevention and remote areas were given priority, but in implementation, curative, urban-centred interventions continued to draw scarce resources. International investments were made in narrow vertical public health campaigns such as those against malaria, schistosomiasis, trachoma, smallpox, and leprosy with mostly disappointing results. The emerging birth control programmes at that time focused on targets rather than needs and wound up with birth rates that were higher than when they started.

Discontented with the state of these curative and vertical programmes, by the 1960’s a movement (which would become known as Community-based Health Programs (CBHPs) as will be explained later) emerged to provide integrated and comprehensive basic health services in several countries (notably in Latin America, India, Bangladesh and The Philippines). News of the success of China’s barefoot doctors and their use of Chinese traditional medicine in providing adequate health care began to come out in the 1970’s. These experiences opened up thoughts and discussions about alternative health care models.

These ideas would galvanize in 1978 at the International Conference on Primary Health Care (PHC) in Alma-Ata. With great optimism, 138 nations resolved to implement PHC as a means of achieving ‘health for all by the year 2000’. J. Galvez-Tan (cited in Bautista 1999) presents a framework for understanding primary health care. It seems particularly relevant today when we are confronted with multiple versions and contexts of PHC (Figure 8.1).

**Figure 8.1** A Framework for Understanding PHC (Source: J. Galvez-Tan, cited in Bautista 1988)

<i>Character</i>	<i>Levels of Primary Health Care</i>			
	<i>Hospital/ Clinic-based</i>	<i>Community- oriented</i>	<i>Community- managed</i>	<i>Community- based</i>
<i>Role of the community in SAPIME*</i>	None	Consulted	Partners of GO/NGO	Managers of development
<i>Role of community organizing</i>	Not important	Means to an end	Means/end	Means/end
<i>Main character</i>	Authoritarian	Paternalistic	Democratic	Liberating
<i>Implications to the community</i>	Oppressive	Deceptive	People gain control of their lives	Self-reliance

\*Situational analysis, planning, implementation, monitoring/evaluation

Using Tan's framework, the most liberating is the community-based model since it is the community that makes the decisions regarding its programme. The community-managed model is the most democratic, where members of the community decide as equal partners. In a community-oriented approach, decisions are made outside of the community, and the members are 'consulted'. The perspective taken is usually that of the health provider, who then solicits inputs from the community. The most oppressive is the clinic- or hospital-based approach where the community plays a passive role, awaiting direction and action from outside, in most cases the medical profession or a national body. Each of these models and their variants exist today and it becomes a challenge for community workers to move communities towards the model of greater empowerment.

It was inevitable that such an ambitious and radical PHC approach would have problems. From the start there were concerns about funding and sustainability (although even then WHO and UNICEF had proposed that resources could be taken from the military and warfare for support to health) (Mull 1990: 32). The year after the PHC conference, a 'selective primary health care' was proposed that would focus on a few, 'cost-effective' interventions such as breastfeeding, immunization and oral rehydration therapy for diarrhoea. This line of thinking led later to the UNICEF GOBI-FFF campaigns and USAID's 'Child Survival Programs' in the '80s. These programmes attracted funding agencies because they were less costly than comprehensive PHC, and because their effects could be measured in terms of health outputs (such as immunization coverage). Moreover, they were attractive because they did not require a 'revolution in political thinking and resource commitment'. They were also agreeable to those in the medical establishment who felt threatened by 'putting health in the hands of the people' as this was 'appropriate technology' that could be under technical control.

The global recession in the 1980's increased the indebtedness of many developing countries and they had to agree to 'structural adjustment policies' that cut their spending for social services, including health. By the 1990's, health had become an investment and its purpose was to enable people to contribute to economic development. The call is now for 'health sector reform' that includes :

- decentralization of management of health services and devolution of policy decisions and priority setting in health care provision to local governments;
- broadening of health-financing options, including the introduction of user fees and other community-financing mechanisms to balance diminishing governmental health budgets;
- working more closely with the private sector by establishing systems for regulating, contracting with or franchising providers in the private sector (Cassels 1995).

\* GOBI stands for: growth-monitoring, oral rehydration, breastfeeding and immunization; FFF for: family-planning, female education and food production.

### 3 Problems in the Implementation of Community Participation in PHC

Community participation is the key to PHC. As Tan's framework shows, without the community, none of these models would exist. The success stories of PHC (Werner and Sanders 1997) appear to be experiences where communities have gained control over their health programmes. In contrast, when the community is ignored, or when its social and cultural contexts are not appreciated, then PHC tends to fail (see Nichter (1990) on 'Vaccinations in South Asia'). Indigenous knowledge needs to be recognized for people to feel that they are respected and only then will they truly 'participate'. Community participation is not easy to incorporate in policies. Because it is so context-bound, it is often difficult to follow this principle in actual planning and programme implementation. In practice, people outside the community tend to take decisions and make the policies. When the community itself discusses, decides and implements the policy, then the policy becomes a part of the community's reality.

Most 'induced participation' in PHC programmes failed simply because socio-cultural factors, the local population's perspectives, and existing community organizations were not sufficiently accounted for in formulating the programme's activities. The methodology for participation did not receive proper attention, and its contextualization was often sacrificed in favour of the need for national standardization. Any viable community-based health care should be founded upon the premise that the programme initiative be tailored to the specific social and cultural context in which it will operate.

Often too little attention has been paid to the differentiation found within village society (Streefland and Chabot 1990). What is a 'community'? This concept has different meanings across various cultures. A village is never an egalitarian whole in which every villager has a say. For example, in rural India, the caste system is still a factor dividing village society. Here, untouchables are excluded from full participation in village affairs. In other societies, women may be excluded from the decision-making process, or state control delegated through local representatives may also lead to unequal power relations, which limit the villagers' participation. The power structure within a village society is more often than not directly reflected in the village health committees and in the selection of village health workers, also known as community health workers (CHWs) in some countries.

The establishment of community health workers (CHWs) has sometimes been considered to be a form of community participation but many countries have found it impossible to sustain a viable, volunteer CHW scheme.

*In The Philippines, PHC was instituted nationwide in 1981. By 1984, there were 380,609 barangay ('village') health workers or BHWs nationwide and 37,705 (98.3%) barangays out of 38,364 had initiated a PHC programme. In 1988, the last year when data were available, only 96.7% of barangays had PHC and the number of BHWs had gone down to 355,990 (Ibon Facts and Figures 1998). The government tried to reactivate PHC in the '90s with a campaign called 'Health in the hands of the people'. Unfortunately, decentralization took place and both the government and communities became too enmeshed in its problems to pay much attention to PHC. Today, PHC is struggling to maintain a path towards true people empower-*



ment in health. BHWs now receive an allowance from local governments and their numbers are increasing once more. This comes at a price, because more and more, they are being co-opted into serving the political agenda of the local chief executive who controls their allowances.

#### 4 Measuring Community Participation

Community participation in development should be seen as a dynamic process. A framework for measuring the level of community participation has been introduced by Rifkin and her associates (1988). The framework is divided into five dimensions: needs assessment, leadership, organization, resource mobilization, and management. The methodology used in measuring these aspects involves the defining of process indicators for participation in health programmes on a continuum developed for all five dimensions (see Figure 8.2). Participation is ranked from 'narrow' (no participation) to 'wide' (high participation). These indicators focus on the breadth and depth of participation and not on its potential social impact. By plotting a point on the continuum and connecting it with all other marks in a spoke arrangement, it is possible to describe a baseline of community participation in a specific health programme.

**Figure 8.1** An Analytical Framework to Measure Community Participation  
(Source: Rifkin et al. 1988: 934)

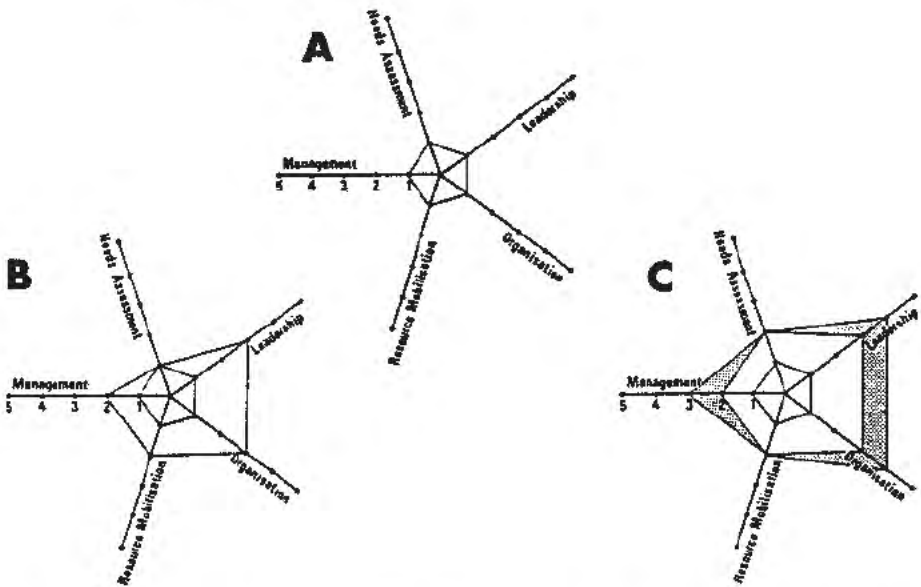

The application of the framework designed by Rifkin et al. was critically assessed by Laleman et al. (1989) while carrying out assessment research in community participation in a community-based health programme in Nueva Ecija, The Philippines. They applied the framework to the programme retrospectively and found it a useful instru-

ment for analyzing community participation, describing what had been achieved and identifying some of the elements that either influenced or hindered the process. The main advantage of the 'spoke' framework seems to be that it provides a common language for different observers and makes it possible to describe and pinpoint the dynamics of the process of community participation. In the case of the Filipino programme it was found that the lack of discussion on needs assessment with the people involved was a major obstacle to the development of a successful community-based programme (Laleman et al. 1989).

### Additional References

Bautista, V.

- 1999 *A State of the Art Review of Primary Health Care in The Philippines: Two Decades of Government Initiative*. University of The Philippines College of Public Administration and Governance.

Cassels, A.

- 1995 'Health Sector Reform: Key Issues in Less Developed Countries.' WHO Forum on Health Sector Reform, Discussion Paper no. 1 (SHS/NHP/95.4). Geneva: World Health Organization.

*Ibon Facts and Figures*

- 1998 Vol 21, No. 19, 15 October 1998.

Laleman, G. & S. Annys

- 1989 'Understanding Community Participation: A Health Programme in The Philippines.' *Health Policy and Planning* 4 (1): 251-256.

Mull, J.D.

- 1990 'The Primary Health Care Dialectic: History, Rhetoric and Reality.' In: J. Coreil and J. Dennis Mull (eds), *Anthropology and Primary Health Care*. Boulder: Westview Press.

Nichter, M.

- 1990 'Vaccinations in South Asia.' In: J. Coreil and J. Dennis Mull (eds), *Anthropology and Primary Health Care*. Boulder: Westview Press.

Ramonos-Jimenez, P.

- 1999 *Immunization in The Philippines*. Het Spinhuis Publishers, Amsterdam.

Streefland, P.H. & J. Chabot

- 1990 *Implementing Primary Health Care. Experiences Since Alma Ata*. Amsterdam: KIT Publications.

Werner, D. & D. Sanders

- 1997 *Questioning the Solution: The Politics of Primary Health Care and Child Survival. With an In-depth Critique of Oral Rehydration Therapy*. Health Wrights, Palo Alto.

World Health Organization

- 1978 *Primary Health Care: A Joint Report by The Directorate-General of the WHO and the Executive Director of the United Nations Children Fund on the International Conference of Primary Health Care in Alma-Ata, USSR, 6-12 September 1978*. New York/Geneva: WHO.

---

## Exercise

### *Small Group Work*

Each person within your group should describe at least one example of a successful and an unsuccessful PHC programme or project from your country. Arrive at a consensus on what are the common factors that contributed to the success or failure of these programmes. Discuss the role of the socio-cultural contexts and how future PHC initiatives might best utilize these perspectives to increase the likelihood of success.

---



**ACCEPTANCE OF VACCINATION AND  
SUSTAINABILITY OF VACCINATION PROGRAMMES**

# ACCEPTANCE OF VACCINATION AND SUSTAINABILITY OF VACCINATION PROGRAMMES

## Objectives

At the end of this Module, the participants should be able to:

- understand the historical development of the Expanded Program on Immunization and the role of organizations involved at different institutional levels;
- define social and cultural aspects of vaccination practice from the perspectives of users, providers, the technology developers and public health planners;
- point out how social science research may contribute to the enhancement of coverage and sustainability of vaccination programmes.

## Literature

Streefland, P.H.

1995 'Enhancing Coverage and Sustainability of Vaccination Programs: an Explanatory Framework with Special Reference to India.' *Social Science & Medicine* 41 (5): 647-656.

Streefland, P., A.M.R. Chowdhury & P. Ramos-Jimenez

1999 'Patterns of Vaccination Acceptance.' *Social Science & Medicine* 49 (12): 1705-1716.

## Contents

- 1 The Historical Background and Global Dimension of Immunization
- 2 The Role of International Organizations, the State, and Non-Governmental Organizations in Immunization
- 3 Vaccine Development and Introduction of New Vaccines
- 4 Vaccination Programmes, Their Culture and Their Context
- 5 Compliance and Resistance

## 1 The Historical Background and Global Dimension of Immunization

At the end of the 18th century the principle originated of protecting children against smallpox by giving them a vaccination with cowpox. Before that time, in parts of Asia and Europe, the practice of variolation prevailed which included inoculation of a child with smallpox matter. Vaccination was probably the most important reason behind the disappearance of smallpox as an endemic disease in Europe during the course of the 19th century. In developing countries, smallpox remained a leading cause of death. In the 1970's a worldwide Smallpox Eradication Campaign was implemented under the auspices of the World Health Organization (WHO). In 1974, in the wake of this successful campaign the Expanded Program on Immunization (EPI) was initiated. This global programme was led by WHO and received strong support from UNICEF. Until recently it aimed at controlling six immunizable diseases: polio, pertussis, diphtheria, tetanus, measles and tuberculosis. In many countries a vaccination against Hepatitis B has now also been included. For the global administration of efficacious vaccines against these diseases, EPI established standard vaccination schedules and surveillance procedures. It provided training and managerial support to national programmes and developed promotional materials. At the beginning of the present century the global effort to eradicate another disease, polio, through immunization, is well on its way.

## 2 The Role of International Organizations, the States and Non-Governmental Organizations

Providing protection against a number of diseases through immunization has become a global endeavour. Multinational pharmaceutical companies, international networks, such as the Global Alliance on Vaccines and Immunization (GAVI) and a variety of donors all play a part in the development and promotion of new vaccines. UNICEF and GAVI play a role in making vaccines available to national governments at a reasonable price. The WHO's EPI programme supports the entire immunization trajectory from vaccine development through vaccination practice. Other WHO units support vaccine development, quality control, and development of vaccination technology. At the country level, national vaccination programmes within the Ministries of Health, following the rules and procedures developed by EPI, are responsible for country-wide child immunization. In many countries this responsibility is shared with non-governmental organizations which may provide training or vaccines to the government programme or implement the entire vaccination programme for a certain area's population.

## 3 Vaccine Development and the Introduction of New Vaccines

The development of new vaccines from the initial concept to the mass-produced vaccine includes a number of important stages and institutionalized procedures. The clinical trials to test the efficacy and safety of the new vaccines are important. One way of looking at the process of vaccine development and introduction is to view it as a

sequence of choices to be made by different groups of actors (designers, biomedical experts and laboratory technicians, epidemiologists, manufacturers, and lobbyists) each with its own culture and interests. New technologies, such as recombinant DNA technology, have broadened the scope of new vaccine development. The Children's Vaccine Initiative (CVI) was a global organizational effort to boost the development of vaccines by involving both the public and the private sector. GAVI has now taken on this role, but also aims to get vaccines to children in developing countries. As yet, most vaccine development and manufacturing takes place in the North, although the production of vaccines included in the EPI schedule in Southern countries including Vietnam, India, Brazil and The Philippines, is of great importance. However, prospects for transfer of the newest vaccination technologies to developing countries are not bright.

#### 4 Vaccination Programmes, Their Culture and Their Context

Vaccination programmes are characterized by a target-oriented approach and emphasis on strict adherence to vaccination rules and procedures that have been developed in an international setting. Responsibilities are clearly defined and the implementation of duties is closely monitored. Usually, the organizational culture of vaccination programmes combines an emphasis on strict adherence to many rules with strong social control through monitoring of the achievement of targets. This is reflected at the operational levels by a culture which emphasizes observance of rules and avoidance of risks. Besides, the programmatic culture will tend to reproduce local beliefs and ideas, such as views on how to behave towards women and female infants or prejudices regarding certain population groups which prevail in the society at large.

In order to achieve a high level of coverage, a vaccination programme will, at least to some extent, purposively have been adjusted to its socio-cultural environment. Seasonal working schedules, nomadic travel patterns, and local ideas about risk are among the socio-cultural elements which vaccinators and programme managers may take into consideration when implementing their vaccination programme. Besides, their services will have to cover places such as urban slums and peripheral villages. A breakdown of health service delivery because of natural disasters, civil war, or economic crises will ultimately also affect immunization, although this health care activity has shown remarkable perseverance and resilience when facing odds.

#### 5 Compliance and Resistance

Sustained high levels of vaccination coverage are only possible when vaccination services are easily accessible and when parents take their children there at the time indicated by the immunization schedule. Whether the children will come regularly and on time will – partly – depend on the perceived quality of the services, including whether or not outreach clinics are held on time, mothers are treated with respect, and vaccines are available. Parents' confidence in vaccination technology, their calculation of the chance of harm through side effects and of health protection through vaccination, and the social control of the community are other determining factors.



There are also groups which do not accept vaccination for their children. When vaccination was introduced by colonial governments in the last century, resistance to it was a rather common response. Presently, such resistance occurs for religious reasons: when parents reject protection through vaccination because they consider this unjustified interference with God's will or because their explanatory model of how a child ought to gain resistance against a disease is at odds with the biomedical model. Collective resistance may also occur when media-supported narratives about adverse effects or undisclosed aims, e.g. sterilization of pregnant women by way of the TT vaccination, circulate through society. Individual refusal is usually related to mothers' tight working schedules or to adverse effect experiences.

### Additional References

Basch, P.F.

1994 *Vaccines and World Health*. New York: OUP.

Chowdhury, A.M.R. et al.

1999 *The 'Near' Miracle Revisited: Social Science Perspectives of the Immunisation Programme in Bangladesh*. Amsterdam: Het Spinhuis.

Chilowa, W. & A. Munthali

1999 *Immunisation in Malawi*. Amsterdam: Het Spinhuis.

Das, A. et al.

2000 'Disease Control and Immunisation.' *Economic and Political Weekly*, 25: 625-633.

Nichter, M.

1995 'Vaccinations in the Third World: A Consideration of Community Demand.' *Social Science & Medicine* 41 (5): 617-632.

Ramos-Jimenez, P. et al.

1999 *Immunisation in The Philippines*. Amsterdam: Het Spinhuis.

Wright, P.F.

1995 'Global Immunization – a Medical Perspective.' *Social Science & Medicine* 41 (5): 609-616.

## Homework Assignment

Read the article by Peter Wright.

Describe in 1 to 2 pages:

- a* How does the author define the role of social science research in immunization?
- b* Elaborate on your view of the role of social science research and social scientists in immunization.

## Exercise

- 1 Suppose you have to do a small study to find out what happens with complaints made by mothers to the responsible person at a health centre about vaccinators' rude behaviour. Make a list of questions you could use when interviewing (a) members of a vaccination team about whom the complaints have been lodged, (b) a programme manager (e.g. the DHO), (c) mothers, and (d) the health centre person in charge.
  - 2 Do 'to comply with vaccinations' and 'to accept vaccinations' have different meanings? Explain your answer. And what about 'to protect against a disease' and 'to prevent an illness'?
-

**MODULE 10**

**REPRODUCTIVE HEALTH**

# REPRODUCTIVE HEALTH

## Objectives

At the end of this Module, the participants should:

- understand the difference between family planning and reproductive health care;
- have gained insight on the role of anthropological studies in identifying reproductive health problems and needs.

## Literature

Aitken, I. & L. Reichenbauch

- 1994 'Reproductive and Sexual Health Services: Expanding Access and Enhancing Quality.' In: G. Sen et al. (eds), *Population Policies Reconsidered: Health Empowerment and Rights*. Harvard Series on Population and International Health. Boston: Harvard University Press pp. 177-193.

Boomongkon, P. et al.

- 1999 'Emerging Fears of Cervical Cancer in the Northeast of Thailand.' *Anthropology and Medicine* 6 (3): 359-380.

Browner, C.H. & C.F. Sargent

- 1990 'Anthropology and the Studies of Human Reproduction.' In: T.M. Johnson & C.F. Sargent (eds), *Medical Anthropology: Contemporary Theory and Method*. New York: Praeger pp. 215-230.

Germain, A. & J. Ordway

- 1989 *Population Control and Women's Health: Balancing the Scales*. New York: International Women's Health Coalition (recommended).

Kirumira, E.K.

- 1998 'Studying Adolescent Sexual Health: Ugandan Experiences.' In: A. Hardon (ed.), *Beyond Rhetoric: Participatory Research in Reproductive Health*. Spinhuis, Amsterdam.

## Contents

- 1 Introduction
- 2 Reproductive Health: A New Concept
- 3 Anthropological Studies on Reproductive Health

## 1 Introduction

During the 1990's there was a shift from family planning towards reproductive health in the international population policy arena. This shift had its origins in two trends. The first is the increasing opposition of women's health advocates to target-oriented family planning programmes which do not respect women's reproductive rights; the second trend is the increasing recognition among policy-makers and administrators of family planning programmes that the effectiveness of the programmes is only likely to increase if the quality of care is enhanced, and if a wider array of reproductive health needs are included.

## 2 Reproductive Health: A New Concept

Reproductive and sexual health as a concept encompasses a set of health problems or diseases associated with the physical and social risks of human sexuality and reproduction. Germain and Ordway (1989) – two women's health advocates – define a reproductive health approach that enables women and men, including adolescents, everywhere to regard their own fertility safely and effectively by conceiving when they desire, terminating unwanted pregnancies, and carrying wanted pregnancies to term; to remain free of disease, disability, or death associated with reproduction and sexuality; and to bear and raise healthy children.

In 1994, participating government delegations at the International Conference on Population and Development (ICPD) in Cairo, agreed that reproductive health care should be made accessible through the primary health care system. Key elements of reproductive health care are:

- family planning services, counseling and information;
- prenatal, postnatal and delivery care;
- health care for infants;
- treatment for reproductive tract infections and sexually transmitted diseases;
- safe abortion services, where legal, and management of abortion-related complications;
- prevention of and appropriate treatment for infertility;
- information, education and counseling on human sexuality, reproductive health and responsible parenthood, and discouragement of harmful practices like female genital mutilation (FGM).

The operationalization of the reproductive health concept is, however, still vague. A problem is that priorities not processes have been stipulated. As a result the implementation of comprehensive reproductive health care is rare in practice.

Implementation of the reproductive health approach requires a revolution in health care. It requires family planning and health administrators to plan jointly the implementation of the programmes and to define cost-effective packages of good quality integrated services shaped to the specific needs of diverse clients in different settings and available to all who need them (Aitken & Reichenbach 1994). Usually existing packages of maternal and child health care (MCH), family planning and STD/HIV/AIDS

control are relabelled as reproductive health care. In terms of the age groups covered, more attention is given to outreach to adolescents. The components of the reproductive health care framework which are rarely implemented in practice are programmes oriented towards the treatment and prevention of infertility and reproductive cancers. These problems, which affect women's and men's lives in profound ways, are generally not considered to be important public health problems by policy-makers and donors.

### 3 Anthropological Studies on Reproductive Health

Anthropological studies on reproductive health contribute to the understanding of folk concepts of ethnophysiology and their relationship to reproductive, therapeutic, and ritual practice; and insight on the structure of decision-making and considerations that inform reproductive choices (Browner and Sargent 1990). Issues that have been studied from an anthropological perspective are paradigms of maternity, the management of obstetrical events, menstrual taboos, perceptions of conception, gestation and fetal development, menopause, infertility and birth control. In women's lives, all these issues are interrelated.

Post-Cairo, there has been more attention for research on adolescent sexuality and health, violence against women, as well as research on abortion issues, and women's experiences with reproductive tract infections. Generally the studies focus on female populations. There is very little study of male reproductive health problems as perceived by men themselves.

An interesting study by Boomongkon and colleagues (1999), reveals how concerned women are about chronic and recurrent uterus-related problems in the North-east of Thailand. Women refer to symptoms ranging from abdominal and lower back pain to vaginal discharge, itching, odor and rash using the term *pen mot luuk* (literally 'it's the uterus'). They fear that these problems will turn into cervical cancer if not treated, a perception inadvertently perpetuated by the cervical cancer education and screening programmes. Eighty percent of women surveyed (N = 1028) reported self-medicating the last time they experienced symptoms. Two-thirds of them bought antibiotics, specifically under-dosages of two brands of tetracycline, Gaano and Hero. Tetracycline is medically inappropriate for many of the problems women classify as *pen mot luuk*, but the manufacturer of Gaano appears to endorse its use by displaying a uterus on the package.

---

## Exercise

- 1 Make a list of questions that may help researchers find out what people's reproductive health problems and needs are.
  - 2 Make a list of questions that enable researchers to find out what people *in the community* think of existing family planning and mother and child care (MCH) services.
  - 3 Make a list of questions to find out what the staff of existing family planning and MCH programmes regard as the needs and rights of the population they are serving.
-





MODULE 11

**FERTILITY BEHAVIOUR:  
A MICRO APPROACH**

## FERTILITY BEHAVIOUR: A MICRO APPROACH

### Objectives

After this Module, the participants should be able to:

- understand fertility behaviour in its socio-cultural context;
- differentiate between various perspectives on fertility behaviour.

### Literature

Caldwell, J.C. et al.

- 1982 'The Causes of Demographic Change in Rural South India: A Micro Approach.' *Population and Development Review* 8 (4): 689-727.

Cottingham, Jane (ed.)

- 1997 'Beyond Acceptability: Users' Perspectives on Contraception.' London: *Reproductive Health Matters* for the World Health Organization.

Inhorn, Maria C.

- 1994 'Kabsa (a.k.a. Mushahara) and Threatened Fertility in Egypt.' *Social Science & Medicine* 39 (4): 487-505.

Kabeer, N.

- 1992 *From Fertility Reduction to Reproductive Choice: Gender Perspectives on Family Planning*. Discussion Paper 299. Sussex: Institute of Development Studies (**recommended**).

Nichter, M.A. & M. Nichter

- 1989 'Cultural Notions of Fertility in South Asia and their Impact on Sri Lanka Family Planning Practices.' In: M. Nichter (ed.), *Anthropology and International Health: South Asian Case Studies*. Dordrecht: Kluwer, pp. 7-30.

### Contents

- 1 What is Fertility Behaviour?
- 2 The Perspective of Policy-Makers
- 3 Acceptability of Family Planning Programmes
- 4 The Importance of a Gender Perspective

## What is Fertility Behaviour?

This Module deals with variations in fertility and their social and cultural background. This Module specifically focuses on how to study fertility behaviour from an anthropological perspective at the micro level of villages, households and individuals. This Module is *not* about the relationship between population size/growth and the available resources, e.g. food, employment, and opportunities to provide everyone with adequate health care and education.

To understand fertility behaviour it is important to know the motives women or men have in pursuing high or low fertility and the ways in which they try to achieve their objective. Among possible reasons for wanting high fertility, the quest for security and risk-aversion stand out prominently. People try to influence their fertility through, for instance, marriage patterns, abortion, and contraceptive use. The anthropology of fertility behaviour focuses on both the forms of such behaviour and the motives behind it. The article by Caldwell et al. (1982) is based on an extensive study of changing fertility and its socio-economic and cultural context in nine South Indian villages. Caldwell suggests that the main reason couples choose for fewer children is to be found in the changing balance between the value of the work children can do and the cost of raising them. The authors argue that the advent and expansion of schooling has played an important role in increasing the cost of raising children while, at the same time, allowing them less time to spend on farm work. The perceived importance of educating children increased with an expansion of urban jobs and local off-farm employment.

Other social scientists have suggested that women's educational status and employment opportunities are important factors in determining fertility behaviour. If women go to high school and follow advanced training, they start having children at a later age. If they have a job, they are likely to further postpone having children. Furthermore, when women earn their own living, children are not their only access to current and future resources.

## 2 The Perspective of Policy-Makers

Policy-makers and health administrators are often concerned that their country will fall into the 'demographic trap'. This, according to some population theories, happens when mortality rates in a country decrease while fertility rates remain high. As a consequence the population grows rapidly and this is seen as a threat to development in poor countries. Accordingly, policy-makers believe that it is necessary to lower fertility levels. The most common means to achieve this is the distribution of contraceptives and the promotion of their use in family planning programmes. Some governments also try to influence fertility behaviour by removing the incentives for women and men to pursue high fertility, e.g. by providing old age security measures, educating women, or creating employment. The perspective of policy-makers and health administrators on changing fertility behaviour may differ drastically from the perspective of local communities. Community members may have good reasons for pursuing high fertility and not using contraceptives, whereas the policy-makers may argue that smaller families

are necessary for a prosperous society. Anthropological studies reveal, for example, that women discontinue contraceptive use due to the fear that side effects will cause infertility. Infertility has not been considered a relevant issue by policy-makers as the suffering of individual women is not their concern. They are interested in interventions that reduce fertility rates and enhance contraceptive prevalence.

One example of an anthropological study that has dealt with infertility was conducted by Inhorn (1994) in Egypt. Inhorn found that among the urban and rural poor of Egypt, female infertility is often attributed to '*kabsa*' (also known as '*mushahara*'), a form of 'boundary-crossing' by symbolically polluted individuals into the rooms of reproductively vulnerable women. When *kabsa* occurs, it causes the 'binding' of women's reproductive bodies, threatening their future fertility and their husbands virile procreativity. Because *kabsa* is viewed as the leading cause of female infertility, an extremely socially stigmatizing condition in Egypt, it is greatly feared by women. Apart from *kabsa*, Egyptians perceive other reproductive 'threats' (neocolonially inspired family planning campaigns) as dangers to the individual, social, and political bodies as well.

### 3 Acceptability of Family Planning Programmes

The 1994 International Conference on Population and Development (ICPD), held in Cairo, emphasized the need to move away from the old 'population control' approaches. Its *Programme of Action* called for continuing research and emphasized that this research 'needs to be guided at all stages by gender perspectives, particularly women's, and the needs of users'.

An article by the Nichters (1989) is one of the early studies which throws some light on the issue of acceptability of family planning programmes by focusing on the views of family planning services' users and contraceptive technologies in Asia. This research shows how people in Sri Lanka view their own fertility and how the contraceptive technologies that are provided are believed to affect the 'flow of bodily fluids'. The article discusses the importance of cultural perceptions of fertility in the South Asian context. Their study of the ethnophysiology of fertility and conception reveals that ideas about a 'safe period' are very common. Many informants from their study perceived the period immediately after a woman's menstrual period as the most favourable for conception. Though modern family planning services are underutilized in Sri Lanka, the use of traditional birth control methods (such as the 'safe period' and withdrawal) is commonplace. This shows that birth control is a culturally 'felt need' for many South Asians. The Nichters argue that these lay notions of fertility will not disappear with mere education. They suggest that by not addressing lay ideas about the ethnophysiology of fertility, current family planning education is less effective than it could be. This article shows how anthropologists can, by documenting people's needs and interests, play an important role in the development of culturally sensitive family planning programmes and reproductive health care. How do people perceive the services that are provided? What do they see as advantages and disadvantages of contraceptive technologies? What traditional fertility regulating practices are common? How can the services be improved to better meet consumer's needs? Other possible research topics focus on the quality of care of the family planning services as perceived by the users. People often complain

that they are not treated with respect and are given insufficient information about the various contraceptive options.

Quality of care has in fact been an important topic in family planning programmes since the early 1990's when programme administrators started drawing attention to the so-called 'unmet' need for family planning. Unmet need statistics had been collected routinely in the demographic health surveys (DHS) conducted with support from USAID in developing countries. The levels of unmet need were found to be high. Unmet need is defined in the DHS as the percentage of reproductive age women not using contraceptives while not wanting to have children. Incidentally, the measure does not consider the fact that some women may not use contraceptives because they are not having sex, nor does it consider traditional methods of family planning that may be used as an alternative to modern contraceptives. To reduce unmet need, it was realized that not only quantity of services but also quality would need to be improved. A spate of studies on quality of care documented problems in contraceptive delivery and information provision.

#### 4 The Importance of a Gender Perspective

When studying fertility behaviour it is very important to apply a gender perspective, i.e. to consider how the social and cultural roles of women and men influence fertility. Women are biologically responsible for bearing children, socially and culturally they usually also carry the responsibility to care for the children. Family planning programmes have been criticized for targeting women (and not men) in order to reduce fertility, while men and extended family members play an important role in determining family size. The article by Kabeer (1992) discusses fertility reduction initiatives from a gender perspective. She argues that fertility behaviour has to be understood in its political and economic context. Changes in the international economy during the past decade have sharpened often conflicting demands on women's lives. Poor women have to contribute to household income while also continuing to care for children. Interventions aimed primarily at fertility reduction by means of contraceptive technologies are not the solution, according to Kabeer. She argues for integrated empowerment strategies that improve women's status and income-earning capacity and enhance reproductive choice. Marginal income-generating projects, popular in many Third World countries, do little to improve women's status and are frequently not even economically viable. Policy-makers have to envisage a wide range of employment opportunities and to guarantee adequate maternity leave, affordable child care, retraining possibilities after a period of absence from the labour market, et cetera. Another critical element in policies for gender equity relates to women's collective mobilization around their needs and interests in the field of reproductive health as well as in other fields.

## Homework Assignment

Read the article:

Nichter M.A. & M. Nichter

- 1989 'Cultural Notions of Fertility in South Asia and Their Impact on Sri Lanka Family Planning Practices.' In: M. Nichter (ed.), *Anthropology and International Health: South Asian Case Studies*. Dordrecht: Kluwer, pp. 7-30.

Describe in one page:

- a which theoretical perspective is used in this article (see Module 3);
- b what the implications of results of the Nichters' study are for the family planning programme in Sri Lanka.

## Exercise

Using the micro approach discussed by Caldwell et al. (1982) describe any social, economic and cultural changes in a rural or urban part of your country which have led to changes in fertility behaviour. Discuss how these changes have come about.

---

**MODULE 12**

**ADOLESCENT SEXUALITY**

# ADOLESCENT SEXUALITY

## Objectives

At the end of this Module, the participants should:

- have gained insights into the social context of adolescent sexuality;
- be able to challenge stereotypes about young people's sexuality;
- be able to formulate innovative research to look at adolescent sexuality.

## Literature

Ford, N.J. & S. Kittisuksathit

1994 'Destinations Unknown: The Gender Construction and Changing Nature of the Sexual Expressions of Thai Youth.' *AIDS Care* 6 (5): 1194.

Kirumira, E.K.

1998 'Studying Adolescent Sexual Health: Ugandan Experiences.' In: A. Hardon (ed.), *In Beyond Rhetoric: Participatory Research in Reproductive Health*. Amsterdam: Het Spinhuis.

UNAIDS

1999 'Sex and Youth: Contextual Factors Affecting Risk for HIV/AIDS.' Geneva: UNAIDS.

## Contents

- 1 Introduction
- 2 Adolescents and Sex: The Health Risks
- 3 Information Needs
- 4 Designing Programmes Aimed at Adolescents



## 1 Introduction

About one-fifth of the world's population is adolescent, a group sometimes referred to as 'teenagers', meaning those aged 10 to 19. In developing countries, the percentage of adolescents may be much higher. Adolescence is a crucial part of every person's life cycle, marking the transition into adulthood. It is often a difficult period as young people search for their identity and social roles.

Societies tend to have ambivalent, even contradictory, attitudes toward adolescents. On one hand, they are seen as children, immature and not to be trusted with responsibilities. On the other hand, adolescents are often forced to assume adult roles. While they are often not allowed to make major decisions, they are forced to join the labour force, conscripted into the military or other armed groups, and made to assume many adult responsibilities. Young girls are sometimes targeted for prostitution.

## 2 Adolescents and Sex: The Health Risks

Adolescents face many risks in terms of their sexual health. There is the risk of unplanned pregnancy and of sexually transmitted disease (STD), including HIV/AIDS. About half of all the people who acquire the HIV infection each year are below age 24. Young girls are at a higher risk for problems such as HIV and STDs because their cervix and reproductive tract are still relatively immature and are more prone to injury and infection.

Premarital sex among adolescents is blamed for being the cause of numerous problems, including HIV/AIDS. People forget that in the past, and to some extent even in the present, adolescent sex took place within marriage simply because people married at much younger ages. This is not to say that early marriage was a good thing. Such marriages, especially when forced or arranged, also created many problems for young people.

What puts young people at risk is not sex itself, but rather sex in conditions where they are unable to make informed choices, e.g. not being able to protect themselves against STDs or an unwanted pregnancy. Furthermore, societies sometimes aggravate existing problems through stigmatization, for example, by expelling unmarried pregnant girls from school.

## 3 Information Needs

Parents will often avoid discussions about sex, fearful that such conversations will make young people have sex. This leaves young people to fend for themselves, picking up information about sex from their peers or from the media. This information is not always accurate or may even propagate dangerous misconceptions.

Young people need information on such basic issues as menstruation, sexual anatomy and physiology. They need to be taught about contraception and ways of preventing STDs, including HIV/AIDS. Such information will not lead to an increase in young people having sex. The World Health Organization reviewed 19 research studies on sex

education programmes for young people and found that these programmes did not lead to earlier or increased sexual activity (See *UNAIDS* 1999). In fact, some of the studies showed there was a delay in the onset of sexual activity.

Sex education should not be limited to technical matters. It also must challenge social norms that put young people at risk. Special attention has to be given to gender inequity. In many societies, adolescence is a time when males receive more privileges while girls, already limited in their social mobility, are subjected to even more restrictions. Sometimes, adolescent health programmes reinforce these norms. Drop-in centres for young people often attract more males than females because social norms do not allow girls to go to such public places, or because the drop-in centre's activities are male-oriented, or their staff may be mainly male.

#### 4 Designing Programmes Aimed at Adolescents

Programmes for young people need to be more gender-sensitive. Sex education programmes have to incorporate 'life skills' in relation to other needs, helping young people to identify and challenge social norms that put them at risk. Young girls have to be encouraged to be assertive and independent, so they protect themselves. Young boys, on the other hand, often need to be taught sexual responsibility especially in societies where machismo values and male domination are still the norm.

Young people's programmes therefore need to look at other issues, such as the use of alcohol among young males. In many societies, drinking is often a group activity that leads to brothels or other places where there is sex work or that contributes to domestic violence.

In the past, research on young adults has tended to be in the form of surveys about their knowledge, attitudes and behaviour. While these studies have been valuable, they need to be enriched by more research on the context of young people's sexuality, from gender norms to the impact of urbanization and globalization. Even more importantly, the research needs to involve young people, allowing their own voices to be heard, so that they can be part of the solution as well.

Innovative methods, especially those that involve the youths themselves, are important to be able to capture the social context of adolescent sexuality and the many different youth subcultures found in each country (e.g., urban versus rural, students versus out-of-school youth). Kirumira (1998) describes the use of peer groups to engage adolescents in a process of defining adolescent sexual and reproductive health needs in Uganda. He points out that adolescents need space to discuss their concerns among themselves. The methodology Kirumira proposes is grounded in group dynamics work, over a long period of time, and involves intense listening to adolescents. Facilitators are trained in group dynamics and transfer these skills to young people. Sessions are taped and researchers gain insights into adolescents' descriptions of their own realities and concerns.

**MODULE 13**

**HIV/AIDS:  
TRANSMISSION AND PREVENTION**

# HIV/AIDS: TRANSMISSION AND PREVENTION

## Objectives

At the end of this Module, the participants should be able to:

- understand and differentiate between anthropological and epidemiological research perspectives on AIDS and HIV transmission;
- discuss characteristic elements of anthropological research on:
  - sexual beliefs and cultural norms that regulate sexual behaviour;
  - sexual practices;
  - popular views of AIDS and HIV transmission;
- discuss how anthropological research can support in formulating and implementing AIDS control interventions.

## Literature

Ford, M. & S. Koetsawang

1991 'The Socio-Cultural Context of the Transmission of HIV in Thailand.' *Social Science & Medicine* 33 (4): 405-414 (**recommended**).

Parker, R.G., G. Herdt, & M. Carballo

1991 'Sexual Culture, HIV Transmission, and AIDS Research.' *Journal of Sex Research* 28 (1): 77-98.

Sibthorpe, B.

1992 'The Social Construction of Sexual Relationships as a Determinant of HIV Risk Perception and Condom Use among Injection Drug Users.' *Medical Anthropology Quarterly* 6 (3): 255-270.

## Contents

- 1 Anthropological Versus Epidemiological Perspectives on AIDS Research
- 2 The Study of Sexual Culture
- 3 Change of Sexual Practices: The Promotion of Condoms
- 4 Methodological Issues in the Study of AIDS

## 1 Anthropological Versus Epidemiological Perspectives on AIDS Research

There are important differences between the epidemiological and the anthropological studies of AIDS. Epidemiology focuses on the prevalence and incidence of the disease, establishes modes of transmission, and defines groups at risk. Anthropological research focuses on popular notions of the disease *and* transmission-related behaviour. Actual practices may differ considerably from cultural ideas. In studying high risk behaviour, the anthropologist will be specifically interested in its social and cultural dynamics and the context which motivates the behaviour.

Although the concept of risk itself is indispensable, anthropological research into AIDS and HIV transmission will try to avoid the trap of restricting itself to dealing only with the so-called 'identified high risk groups'. As a result of their own or other's behaviour, everyone is, relatively speaking, at risk. Anthropologists find it often useful to focus on *high risk behaviour* rather than on categories of membership, such as homosexual versus heterosexual, male versus female, intravenous drug user versus non-intravenous drug user. The definition of such so-called 'risk groups' may lead to stigmatization of risk group members, and to the building of a false sense of security among people outside this group. On the other hand, since anthropology is concerned with groups and group norms, and since the risk of acquiring HIV is not distributed equally throughout the whole population, the concept of 'risk groups' cannot be discarded completely nor can their existence be denied.

## 2 The Study of Sexual Culture

As sexual behaviour is one of the most significant factors in the spread of HIV, culturally sensitive knowledge of *ideas about sexuality* and of *sexual practices* are needed in order to adequately understand patterns of HIV transmission, and to design more effective intervention programmes. Studies of such behaviour and its social and cultural context are of paramount importance. Sexual behaviour is not solely a biological phenomenon but is also meaningful behaviour involving social relations between partners. Social bonding such as respect, trust, and support through sexual behaviour is a universal human phenomenon. The intimate and private nature of sexuality requires ethnographic, meaning-centred studies which can illuminate both high risk and preventive behaviour in the context of human relationships.

According to Parker et al. (1991) the study of sexual culture includes four basic elements: sexual categories and classifications; sexual practices including their context and their subjective meaning; erotic significance of sexual behaviour (criteria for partner selection, notions of desire and pleasure); and contraception and sexually transmitted diseases.

## 3 Change of Sexual Practices: The Promotion of Condom Use

Sexual practices have proven difficult to change. Contemporarily, condoms are promoted most often as a device to avoid sexually transmitted diseases (STDs) including

HIV. However, *condom use* often represents a decision to have 'unnatural' or 'undesirable' sex, for example with prostitutes. The use of condoms during sexual intercourse may even become symbolic of suspicion and mistrust. This leads to problems in negotiating condom use among partners who are socially intimate. Resistance to the use of condoms during sexual intercourse remains a major factor in the continuing sexual transmission of HIV. Since condoms are also most often associated with family planning programmes they are, consequently, almost never used in contacts between men having sex with men or in anal intercourse contributing to the rapid spreading of HIV in large parts of Asia.

Understanding decision-making and power in sexual relationships is crucial to promoting and predicting condom use (Kane 1989). In many countries sexual politics between men and women limit women's negotiating power in a sexual relationship. Passivity, powerlessness, high dependency on men among the majority of women, along with economic insecurity in many societies, have all been identified as important contributory factors. Sibthorpe's article (1992) explores the basis for low levels of condom use and the apparent cognitive barriers to perceiving personal risk of sexual transmission of HIV among injection drug users. Certain existing beliefs such as the notion that sexual intercourse without a condom with someone known to you is 'safe', as well as interpreting 'cleanliness' as a sign of the safety of a sexual partner, all contribute to the complexity and resilience of personal risk denial among partners.

Cultural factors, social institutions, worldviews and the specific nature of social relationships, in addition to power relations, contribute to and perpetuate the widespread *commercial sex industry*. Ford and Koetsawang's article (1991) delineates the social context of the commercial sex industry in Thailand in terms of its historical and cultural background; the social and regional distribution of wealth and livelihood opportunities; and social and community attitudes to involvement in different shades of prostitution (1991: 410). For example, the high value placed on the virginity of girls in Thailand contributes to the huge demand for commercial sexual services. Since prostitution is invariably a profession with low status, this has consequences for access to health services both for the sex workers and their clients. Untreated STDs contribute considerably to the risk of acquiring HIV.

In many developing countries in Asia, HIV transmission is beginning to reach epidemic proportions. The 'sexual route' transmission is by far the most important. Unfortunately, sexual culture is highly resistant to change and actual sexual practices are often not directly addressed to in AIDS campaigns. Politicians prefer to remain silent about 'undesirable' forms of sexual conduct. The implicit meanings of messages of national AIDS campaigns, and their, often unintended, effect on the receiving public, form an challenging field of study for anthropologists and others interested in the effects of health education.

HIV transmission not only occurs through unprotected sexual intercourse or intravenous drug use. Researchers should be aware of other possible routes of HIV transmission such as the iatrogenic route (transmission of HIV through medical interventions such as blood transfusion, infected needles or instruments). The widespread popularity of injections and the poor hygienic conditions in many health institutions may increase the risk of spreading HIV. Very few researchers have examined this (possible) focus of infection nor determined its real importance.

#### 4 Methodological Issues in the Study of AIDS

The article by Parker et al. (1991) identifies the key research issues, and possible methodologies, for the qualitative investigation of sexual culture in relation to HIV/AIDS. The authors propose that sex research into AIDS must address distinctions between *cultural ideas* and *actual practice*, *public and private conduct*, and *prescribed and voluntary behaviour*. The authors suggest the value of qualitative methods (secondary sources of information, ethnographic observation, focus group discussions, in-depth interviews, sexual diaries and linguistic analysis) for eliciting types of behaviours and for providing explanatory models. These methods provide insights indispensable to the development of more effective AIDS prevention strategies.

Although acquiring knowledge of the socio-cultural background of AIDS and its spread is necessary, it is not sufficient to formulate and implement effective intervention methods. For anthropological studies to contribute to intervention policies, it is essential that from the onset this research be closely related to policy-making and implementation, and that the community affected is involved in the development of the intervention programme.

## Additional References

Kane, S.

- 1989 'The Exchange of Body Fluids in the Age of AIDS.' Paper presented at the Society for Applied Anthropology, Santa Fe.
- 

## Exercise

- 1 How do you think public health doctors and anthropologists working on HIV/AIDS-related problems should collaborate to raise the chance of formulating and implementing effective interventions?
  - 2 What are the main priority objectives and major research questions with respect to anthropological studies on HIV/AIDS in your country?
-



**COPING WITH CHRONIC ILL HEALTH**

# COPING WITH CHRONIC ILL HEALTH

## Objectives

After this Module, the participants should be able to:

- give a definition of coping and explain different forms of coping;
- understand the meaning of stigma;
- apply both concepts to situations in which people are confronted by chronic ill health, including HIV/AIDS.

## Literature

Charmaz, K.

- 2000 'Experiencing Chronic Illness.' In: G.L. Albrecht et al. (eds), *The Handbook of Social Studies in Health and Medicine*. London: Sage, pp. 277-293.

## Contents

- 1 Definition and Forms of Coping
- 2 Coping with Chronic Ill Health
- 3 Chronic Illness and Stigma

## 1 Definition and Forms of Coping

Coping has been used in relation to psychological, physical or material hardships. Here, we use it in relation to chronic ill health. To cope with an emotionally or bodily harmful or unpleasant condition means to deal with it by either solving a problem, if that is involved, or by enduring the condition. The first way of coping has been called direct actions (Lazarus 1976) and problem-solving (Streefland 1996). It is directed at changing the problematic situation. The other main form has been called palliation (Lazarus 1978) and adaptation (Streefland 1996). Though it is tempting to see the first form as active and short-term, and the second as passive and more long-term, that is not always the case. Problem-solving may be a lifelong effort in an environment where ideas are always changing and new technologies and insights emerge continuously. Palliation, in the sense of seeking comfort, support or mitigating medicines, may be a very active way of coping.

## 2 Coping with Chronic Ill Health

Chronic illness will be with someone and her or his environment for a long time, sometimes severely limiting the ill person's capabilities. Chronic illnesses include a wide range of ailments. First, infections which in the course of time, and often depending on access to appropriate medicines, will assume a chronic character, as is the case with HIV/AIDS. Second, they include non-infectious health problems, such as diabetes. Third, they include mental illnesses. Fourth, there is a wide range of chronic pains, disabilities and impairments which may be the consequence of dismal labour conditions, accidents, congenital disorders, or reproductive health problems. Chronic illness is to a large extent a living problem, and not only a medical one.

Corbin and Strauss (1988) distinguish three forms of coping by the chronically ill and their families with the problems they face during an illness trajectory. All activities done by them which are directly related to managing and treating the illness, such as seeking treatment and taking medication, they call *illness work*. Everyday activities such as eating, bathing, shopping, going to work, in other words, all activities also done by a healthy person, they call *everyday work*. Finally, all changes and adaptations in one's life as a consequence of the ill health, including psychological and behavioural adjustments by the ill person, they call *biographical work*. It may be added that caring for someone who is chronically ill may also cause problems of stress, necessitating the carer to find ways of coping. Besides, we should not forget that chronic ill health may also cause problems in the material sphere, as income may be reduced while costs increase. And as Weitz (1991) points out in regard to HIV/AIDS, and Reynolds-Whyte (1997) in regard to misfortune in a more general sense, coping with uncertainty is very important for the people involved.

### 3 Chronic Illness and Stigma

Experiencing stigma is a common consequence of chronic illness. It is a constant threat in some chronically ill individuals' view and makes such a person vulnerable (Charmaz 2000). A stigmatized person is considered flawed, spoiled, discredited. Stigma is an attribute, an undesirable differentness that discredits or disqualifies an individual from full social acceptance (Goffman 1963). A stigma often becomes what Charmaz (2000) calls a master status, such as 'leper' or 'AIDS patient' overriding all other statuses and identities. One becomes a disabled mother or a disabled worker.

A stigmatizing condition may be easily known, or observable, but also undisclosed. In such a case the ill person involved has to cope with the problem of whether or not, to whom, when and how to disclose the condition. Stigma is a social and a cultural phenomenon: when a person will be stigmatized and if so, how she or he will then be treated, is a matter of social relations and cultural expressions. It has been pointed out (Charmaz 2000) that apart from the stigma attached by others, the felt stigma is important, which comprises fear, guilt and shame. When chronically ill people experience that they are unable to perform basic forms of bodily functioning, which are appropriate in their culture, this may increase guilt and shame.

AIDS is a stigmatized condition because it carries many symbolic associations with 'danger'. Attributions of pollution, contagion, incurability, immorality, and punishment for sinful acts are common in many Western and non-Western societies. Since AIDS is associated with immoral, deviant and illegal behaviour (e.g. homosexuality, sexual promiscuity, intravenous drug use), any contact with the real or imagined bearer of this disease must be avoided.

Quam (1990) argues that beliefs about AIDS as a 'polluted disease' reflect people's negative attributions of the routes through which HIV enters the body: the anus because of faeces, the vagina due to menstrual blood flow, and the penis because of urination, ejaculation, and penetration of the 'dirty' vagina or anus. In addition, symbolic thinking that equates 'dirty' semen and blood with pollution and death intensifies the sense of the polluting power of AIDS and the fear of disease. In Thai culture, the symbolic perception of AIDS as a polluting disease is reflected in the decision by sex workers to use condoms with clients whose bodies they consider 'unclean'.

## Additional References

Corbin, J.M. & A. Strauss

1988 *Unending work and care: Managing chronic illness at home*. San Francisco: Jossey-Bass.

Goffman, E.

1963 *Stigma: Notes on the Management of Spoiled Identity*. Englewood Cliffs, NJ: Prentice-Hall.

Quam, M.D.

1990 'The Sick Role, Stigma, and Pollution: The Case of AIDS.' In: D.A. Feldman (ed.), *Culture and AIDS*. New York: Praeger Publishers, pp. 29-44.

Reynolds-Whyte, S.

1997 *Questioning misfortune: The pragmatics of uncertainty in Eastern Uganda*. Cambridge: Cambridge University Press.

Scheper-Hughes, N.S. & M.M. Lock

1981 'Speaking "Truth" to Illness: Metaphors, Reification, and Pedagogy for Patients.' *Medical Anthropology Quarterly* 13: 137-139.

Streefland, P.H.

1996 'Mutual Support Arrangements Among the Poor in South Asia.' *Community Development Journal* 31 (4): 302-318.

Weitz, R.

1991 *Life with AIDS*. Brunswick and London: Rutgers University Press, pp. 52-78.

## Exercises

### *Individual:*

Make an inventory of psychological and social problems encountered by an asymptomatic HIV-infected man who has decided to disclose his condition to his wife.

### *Multi-cultural group:*

Discuss whether or not, and – if so – how a person who is chronically ill would be stigmatized in your society. Which chronic ailment would be most stigmatizing, which least? Would there be differences between men and women? Would there be a culturally sensitive and socially appropriate way in which health workers could effectively interfere in the stigmatizing process?

---

**MODULE 15**

**USE AND DISTRIBUTION  
OF PHARMACEUTICALS**

# PART I

## USE AND DISTRIBUTION OF PHARMACEUTICALS

### Objectives

At the end of Part I of this Module, the participants should be able to:

- describe socio-cultural aspects of pharmaceutical provision and use in the context of essential drugs programmes;
- understand specifically the process of cultural re-interpretation;
- understand major public health problems related to people's self-medication practices and doctor's prescribing patterns;
- know the types of research methods that can be used to study drug use and distribution, including the advantages and disadvantages of each method.

### Literature

Nichter, M. & N. Vuckovic

- 1998 'Understanding Medication in the Context of Social Transformation.' In: S. van der Geest & A. Rienks (eds), *The Art of Medical Anthropology. Readings*. Amsterdam: Het Spinhuis, pp. 335-344.

Van der Geest, S. & A. Hardon

- 1988 'Drug Use: Methodological Suggestions for Field Research in Developing Countries.' *Health Policy and Planning* 3 (2): 152-159 (**recommended**).

Van der Geest, S. & A. Hardon

- 1990 'Essential Drugs: Are We Missing the Cultural Dimension?' *Health Policy and Planning* 5 (2): 182-185.

### Contents

- 1 The Popularity of Pharmaceuticals
- 2 Prescribing Practices and Self-Medication
- 3 Essential Drugs Programmes
- 4 Study of Drug Use: Methodological Issues



## 1 The Popularity of Pharmaceuticals

Pharmaceuticals play an increasingly important role in health care all over the world. Since the 1980's, many publications have pointed to the medically unsafe use of Western pharmaceuticals in developing countries where regulations are weak and health care systems do not function well. People not only use modern pharmaceuticals on the advice of doctors; a large proportion of illness cases is self-medicated, often with potentially hazardous prescription-only drugs.

Anthropologists have tried to explain the popularity of medicines by studying the constellations of cultural meanings and social relations within which they exist in a given time and place. One important characteristic of pharmaceuticals is their 'concreteness'. Healing power is embedded in a capsule or pill which can be consumed by an ill person without interference from others, thus giving the patient a certain amount of autonomy in health care. Furthermore, pharmaceuticals carry connotations of modernity, hygiene, 'foreignness' and industrial development.

Many authors have warned that the pursuit of health is becoming increasingly 'pharmaceuticalized'. People often feel that 'a pill is needed for every ill'. Reasons for preferring treatment and self-treatment with Western medications are not only related to convenience, cost, and perceived effectiveness; medicines are also vehicles of cultural and symbolic meanings and ways to cope with poverty. Popular criteria in choosing drugs are indications, perceived efficacy and severity of the complaints. Dosage, form (injections are often believed to be more powerful than capsules which in turn are stronger than pills) and other attributes such as colour, taste, brand name, and packaging are also important reasons for preference. Increased dependence on pharmaceuticals is part of daily life for poor city dwellers. The monetary economy makes them sick and at the same time creates a demand for drugs, especially those offering quick relief, since they cannot afford to miss one day of work.

## 2 Prescribing Practices and Self-Medication

Self-medication influences health workers' prescribing practices and vice versa. Drug utilization studies suggest that, all over the world, health workers overprescribe drugs. The overuse of antibiotics and injections has serious public health consequences. The strong faith of lay people in the healing power of Western medicines explains in part the overabundant prescription of pharmaceuticals by health professionals. Reasons for prescribing medicines without medical necessity are related to patient demand and expectations, and doctors' attempts to please patients and safeguard their private practice. The predominance of commercial pharmaceutical marketing in the absence of independent drug information also plays an important part. Many doctors have a lax attitude towards potentially dangerous drugs, and downplay their side effects and contra-indications. Furthermore, doctors' motives for prescribing drugs, especially antibiotics, to treat common, non-serious diseases such as acute diarrhoea and cough and colds, are often based upon erroneous assumptions on the necessity to 'eradicate all bacteria' or on the idea that complications may be prevented by using a 'shotgun' therapy of many different drugs at the same time.

Apart from economic waste on the individual and national level, many public health risks are associated with the inappropriate use of drugs. These may vary from temporary minor side effects to more serious complications such as rare but dangerous side effects, drug interactions, overdose or drug-induced illnesses. A growing number of developing countries are also being confronted with increasing bacterial resistance due to the indiscriminate use of antibiotics. This implies that more expensive and more aggressive antibiotics are needed to combat common infections such as gonorrhoea, urinary tract infections and pneumonia.

### 3 Essential Drugs Programmes

In response to the overabundant use of pharmaceuticals both by consumers and providers and in an attempt to limit the number of dangerous drugs or drug combinations on the market, *essential drugs programmes* have been developed in many countries as a part of a national drug policy. These programmes aim at rationalizing the supply and use of drugs. Essential drugs are those which meet the major health care needs for the majority of the population. Experience shows that the number of necessary drugs is relatively small. Drug selection should be based on evaluations of benefit and safety, and of cost. The selected pharmaceutical products should also meet adequate quality control standards (WHO 1988).

Van der Geest and Hardon (1990) argue in their article 'Essential Drugs: Are We Missing the Cultural Dimension?' that in formulating and implementing these programmes, socio-cultural aspects of drug use and provision have been neglected. Two trends are important in this regard:

The first is that people apply traditional concepts of efficacy to their use of modern pharmaceuticals. For example, people in The Philippines expect an anti-diarrhoeal treatment to 'harden the stools'. This hardening effect is assigned to both traditional herbal remedies such as *bayabas* (guava leaves), and some popular anti-diarrhoeal preparations. In contrast, oral rehydration solution (ORS), the preferred treatment in public health, is said to 'clean the intestines' but is not considered very effective in the treatment of diarrhoea (Hardon 1991: 117). This process, which is called *cultural reinterpretation*, shows to what extent Western pharmaceuticals have been incorporated into local culture. Some modern pharmaceuticals have been available and used for a long time and people are familiar with them through doctors' prescriptions and self-medication. These *indigenised pharmaceuticals* are much in demand and widely available. This trend should be acknowledged in programmes that aim at rationalizing the use of pharmaceuticals and health workers and planners should study local drug use patterns before embarking on their campaigns (Haak & Hardon 1988).

The second trend is that pharmaceuticals have increasingly become *commodities* with a commercial value. They are sold through informal drug distribution channels – grocery stores, drug pedlars and markets – in developing countries. Essential drugs, often provided free of charge through the basic health services, leak into this informal sector.

## 4 Study of Drug Use: Methodological Issues

Many studies have been conducted on drug use and provision in developing countries. However, most of these studies are descriptive in nature and focus on drug providers. Few studies have looked into self-medication practices at the community level of health care and even fewer studies are anthropological in their approach.

Van der Geest & Hardon (1988) state that in conducting studies on pharmaceutical use and distribution, it is important to clearly define the focus of the study. The focus could be either *user-* or *provider-*oriented, and the issue at stake could be either the *illness* or the *drug*. The advantage of illness-centred research is that starting with the illness, one can ask what people are undertaking individually to get rid of the problem. This may include non-pharmaceutical self-care practices. The illness-centred approach allows for a smooth transition during the interview from local etiology and illness perception to drug choice.

A drug-centred approach may reveal the different purposes for which one drug is being used, and the drug's specific attributes and perceived qualities can be explored. For example, Hardon (1991: 119-120) found that among the urban poor of Manila branded drugs with the same pharmacological contents are valued differently. People appeared to distinguish a specific brand for every illness.

### Additional References

Haak, H. & A.P. Hardon

1988 'Indigenised Pharmaceuticals in Developing Countries: Widely Used, Widely Neglected.' *The Lancet* Sept. 10: 620-621.

Hardon, A.P.

1991 *Confronting Ill Health. Medicines, Self-Care and the Poor in Manila*. Quezon City: Health Action Information Network.

Van der Geest, S. & S.R. Whyte (eds)

1991 *The Context of Medicines in Developing Countries. Studies in Pharmaceutical Anthropology*. Amsterdam: Het Spinhuis.

World Health Organization

1988 *Guidelines for Developing National Drug Policies*. Geneva: WHO.

## Exercise

The exercise will be conducted in two groups, one on *prescribers* and one on *consumers*. The two groups will answer similar questions.

*For the group on consumers:*

- 1 What problems with respect to drug use are prevalent among consumers? Select a core drug use problem.
- 2 What factors influence this core drug use problem; can you draw a diagram to clarify in what way the factors influence the core drug use problem?
- 3 What type of research methods are most appropriate to study drug use by consumers?
- 4 How, in your view, can research on this core drug use problem contribute to a more appropriate use of drugs by consumers?

*For the group on prescribers:*

- 1 What problems are involved in drug prescription? Select one important problem.
  - 2 What factors influence this important drug prescription problem; can you draw a diagram to clarify this? Try to categorize the factors; and structure them in terms of service-related factors; socio-economic factors; and patient-characteristic factors.
  - 3 What type of research methods are most appropriate to study this important drug prescription problem?
  - 4 How, in your view, can research on drug prescription contribute to their more appropriate prescription?
-

## PART II

# CASE STUDIES

### Objectives

At the end of Part II of this Module, the participants should have gained:

- insight into the methodological aspects of drug-utilization research by discussing in detail the methods used in one case study;
- an understanding of self-medication practices in Thailand and The Philippines, including similarities and differences found in two case studies.

### Literature

Adome, R.O. et al.

1996 *Popular Pills: Community Drug Use in Uganda*. Amsterdam: Het Spinhuis.

Hardon, A.P.

1991 *Confronting Ill-Health. Medicines, Self-Care and the Poor in Manila*. Quezon City: Health Action Information Network, pp. 103-133.

Le Grand, A. et al.

1993 'Enhancing Appropriate Drug Use: The Contribution of Herbal Medicine Promotion.' *Social Science & Medicine* 36 (8): 1023-35.

Rasmussen, Z.A. et al.

1996 *Enhancing Appropriate Medicine Use in the Karakorum Mountains*. Amsterdam: Het Spinhuis.

Sringernyuang, L.

2000 'Availability and Use of Medicines in Rural Thailand.' Chapter 8: *Motluuk ak seep: Antibiotics and the Sick Womb*. Unpublished PhD Thesis, University of Amsterdam.

Whyte, S.R.

1998 'Pharmaceuticals as Folk Medicine. Transformations in the Social Relations of Health Care in Uganda.' In: S. van der Geest & A. Rienks (eds), *The Art of Medical Anthropology. Readings*. Amsterdam: Het Spinhuis, pp. 319-334.

## Contents

- 1 Case Study from The Philippines
- 2 Case Study from Thailand (a)
- 3 Case Study from Thailand (b)
- 4 Case Study from Pakistan
- 5 Case Study from Uganda

## 1 Case Study from The Philippines

The Philippine case study (Hardon 1991) reveals how people define ill-health in relation to food, hygiene and appropriate self-care. Illness is perceived as caused by environmental factors, particularly heat and cold. People take drugs to relieve their symptoms. People generally consider a drug effective if it causes symptoms to disappear, not on the basis of *how* the medication cures the disease. What matters is that the patient no longer suffers from the symptoms. Some of the concepts explained in Module 15, Part 1 such as cultural reinterpretation are illustrated in this case study.

Respondents in Manila explain the inefficacy of therapies, traditional as well as modern, with the concept of *hiyang* (suitable, appropriate). If the therapy does not work, then apparently the therapy was not *hiyang*. These findings suggest that people actively evaluated the effect of therapies. This active evaluation should constitute the basis for education on the rational use of drugs. Ideally, such education should take into consideration people's definitions of health and illness.

## 2 Case Study from Thailand (a)

The first Thailand case study (Le Grand et al. 1993) focuses on the use of herbal drugs and modern pharmaceuticals in self-medication. In self-medication the share of herbal drugs is much smaller than the share of modern pharmaceuticals. Herbal drugs are mainly used to cure locally defined illnesses and stomach-related ailments. For the majority of common illnesses such as headache and flu, the villagers in Thailand self-medicate with modern pharmaceuticals which are much more accessible and, in their view, more effective.

## 3 Case Study from Thailand (b)

The second case study from Thailand (Sringernyuang 2000) discusses self-medication among Thai rural women who experience abdominal pain in combination with lower back pain, particularly during harvesting season. Women who suffer from these complaints start self-medicating with certain antibiotics which are widely available in Thailand. Sometimes these drugs are even taken to prevent the symptoms from appearing. Lay etiologies include hard work after childbirth, effects of contraceptive methods, and pathologies of the womb. Some pharmaceutical companies use lay notions about the symptoms and the popular concept of *ak seep* in their marketing strategies for antibiotics.

## 4 Case Study from Pakistan

In the Northern Areas of Pakistan community drug use in villages covered by the health programme of a NGO was compared with that in villages outside the programme's catchment area. The NGO aimed at enhancing rational drug use by including

standard drug lists for all levels of health workers, regular drug supply and health education for consumers. Other sources of drugs in the area are drug stores and shops, and government dispensaries and hospitals. Medication use was assessed for reported compliance, prescription, and consumption by patients, using *British National Formulary* standards. In the NGO-covered area 45% of the medicines were used correctly, considering dose, frequency and treatment duration, compared to 19% in the other villages. In all villages people rely heavily on modern pharmaceuticals to treat illness, and often use multiple treatments. Reasons given for using various treatments simultaneously include fear of death, lack of trust in a single treatment, plus the desire for a fast cure. In the villages falling under the NGO programme more women expressed the idea that drugs could be dangerous when not taken properly, but in other villages women asked why drugs would be given if they were dangerous (Rasmussen et al. 1996).

## 5 Case Study from Uganda

In Uganda a rapid process of privatisation in health care has occurred during the last 15 years: drug shops and private clinics have been established widely. Patients at government clinics have instead become customers and consumers. The change in patients' status has also happened at government facilities, where nowadays fees must be paid. The public sources of drugs, treatment and medical advice are closely related to the private ones. Government health workers often augment their low incomes with private practice. Patients at government facilities are referred to private ones. Medicine users mentioned the convenience, courtesy and economy of private drug providers. The drug provision system prevailing in Ugandan villages includes several contradictions. There is a strong wish among policy-makers, adhering to the past's high standards, to make drugs and health care widely accessible through government channels, but there are insufficient resources to do so. In addition, policy-makers do not want to face the changed reality and use the private care providers, as they are afraid they will lose control. The government would like to better educate the public in appropriate use of medicines, but refrains from training shopkeepers as this might be considered recognition of their medicines trade (Adome et al. 1996, Whyte 1998).

---

### Exercise

The exercise of Part I continues and the outcome is presented in a plenary session.

---



**GROWING OLD IN CULTURAL PERSPECTIVE**

## GROWING OLD IN CULTURAL PERSPECTIVE

### Objectives

At the end of this module the participants should be able to:

- understand the process of ageing from a cultural point of view;
- discuss crucial aspects of growing old in anthropological terms;
- develop a comparative perspective in the analysis of ageing patterns.

### Literature

Ingstadt, B. et al.

- 1992 'Care for the Elderly, Care by the Elderly: The Role of Elderly Women in a Changing Tswana Society.' *Journal of Cross-Cultural Gerontology* 7 (4): 379-98.

### Contents

- 1 The Cultural *Perspective*
- 2 Themes:
  - demographic conditions;
  - care;
  - generation conflict;
  - successful ageing;
  - death.

## 1 The Cultural Perspective

Anthropology wants to uncover the cultural – and therefore contingent – roots of things taken for granted. At first sight, there seems to be little reason to look at ageing as a cultural phenomenon. Growing old is a natural process which can be explained in biological terms. Comparing patterns of growing old and images of old age in different societies teaches us, however, that social and cultural environments have a profound impact on the appreciation, experience and way of growing old. The adage that biology is not destiny also goes for ageing. The basic principles of ethnography and anthropological reflection can be fruitfully applied to the study of old age.

Until quite recently, anthropologists hardly took an interest in elderly people as *elderly*. They favoured elderly people as key informants because of their superior knowledge of local customs, but age itself was not discussed. This has changed, no doubt under the influence of the ‘greying’ of the anthropologists’ own society where old age has now become ‘an issue’. At the moment there is an impressive body of literature on old age and culture (e.g. Fry & Keith 1980, Sokolovsky 1990, Spencer 1990, Rhoads Holmes & Holmes 1995).

Stereotypes and generalisations surround old age. *Contextualization* by way of anthropological fieldwork allows us to understand the meaning of growing old in different settings and to observe directly how elderly people act and are treated in daily life situations.

Contextualization leads to a more valid *interpretation* of growing old. The way elderly people dress, interact and communicate with younger people, are portrayed in the media, their living conditions, their mobility and involvement in economic activities, their role in politics and religious affairs, the care and support they enjoy, etc. teach us the appreciation and meaning of old age in a specific community. Forced retirement at the age of 65 in Dutch society, for example, produces another experience of being old than continued involvement in economic and political affairs as may happen in Ghana. Admission to an institution, living alone in a private apartment or staying in the midst of a three or four generation household will lead to different ‘realities’ of old age.

The distinction between *emic and etic perspectives* is particularly relevant to old age. There may be a vast gap between the perception of others and how elderly people view themselves. Most ‘Western’ societies have been dubbed ‘youth-centred’; youthfulness is the cultural model and ‘old’ is a predominantly negative word. People dress and behave in order to look young and asking someone’s age is ‘not done’. Elderly people may resent this negative image and feel marginalized. By contrast, elderly people among the Berti in Sudan retain considerable influence by manipulating the marriages of their children (Holy 1990). Elders in Ghana – another example – do not hide their old age but boast about it; they claim they are ‘more grown’, i.e. are more mature, fuller, human beings than the young and should therefore be respected. Growing old in Ghana is a linear process whereas in Europe ageing is often described as making a full circle and returning to the stage of infancy with its dependence and restrictions. Where such cultural stereotypes exist, the anthropological approach may be able to scratch below the public images and explore how elderly people themselves look upon their situation.

Without *comparison*, there is no anthropology. If anthropology can be called ‘the science that teaches alternative ways of living’, this certainly applies to the topic of old

age. Different perceptions of old age and different styles of coping with it are illuminating and help people to look critically at their own traditions of dealing with ageing. Such openness to alternatives is the fruit of *cultural relativism and respect for other cultures*, the cornerstone of cultural and medical anthropology.

## 2 Themes

Certain themes are particularly relevant in a comparative anthropological study of old age because they occur – in varying appearances – in all cultures and societies.

The study of *demographic conditions* is crucial for the understanding of the position of elderly people in a given society. Economic growth and improved health care have greatly changed the demographic situation in the industrialized world. Life expectancy has risen explosively, leading to an ever-larger number of elderly people, thus increasing the burden on the young. For many, the period of being old has expanded from a few years to thirty years and more. This demographic transition is now also taking place in the Third World.

The question of *care* poses itself inevitably when we study conditions of old age in different social and cultural settings. Large variations occur as to what care activities are performed, by whom, for whom, what arrangements exist, and what factors determine the quality of care. Writing about Japan, Ogawa and Retherford (1993: 586) remark that ‘the burden of caring for elderly parents tends to shift from adult children to the state, to businesses, unions, and other private sector organizations, and to the elderly themselves.’ However, where care of the elderly is shifted to institutions and organizations, elderly people still long for companionship and emotional support from relatives and friends. Loneliness may go hand in hand with efficiently organized technical and material care.

The concept of ‘care’ suggests dependence on the part of the elderly but in many societies the reverse occurs as well: gerontocratic features exist worldwide in the sense that elderly people retain power by their control over material, social, and religious matters. Their command over marriage cattle in Eastern and Southern Africa is a case in point. Young people may resent their elders’ refusal to hand over power and accuse them of witchcraft and other evil practices (Foner 1984: 157–92)). The *generation conflict*, in particular between fathers and sons, has also caught the attention of psychologists and psychiatrists and has become a popular theme in literary works.

The concept of ‘*successful ageing*’ provides a counterweight to the largely negative perception of growing old in industrial societies. It stresses the beauty and pleasures of ‘later life’. Successful ageing is ‘measured’ in terms of health, social, psychic, and cognitive functioning and emotional well-being (Baltes & Baltes 1990). In non-industrialized communities successful ageing depends mainly on one’s success in life before growing old. Those who managed to accumulate sufficient material and social capital can be certain of continued support and security in old age.

Old age eventually leads to *death*. The way people deal with death has innumerable cultural variations. In most societies death is a welcome ‘visitor’ to the elderly person and her or his death is generally regarded as a ‘good death’. In several societies ‘death-hastening’ practices have been reported (Glascock 1990). The advancements of medical

technology have turned death into a problematic phenomenon, however. Death is postponed and elderly people, according to some critics, are denied the right to die peacefully. This development had led to moral, medical and religious debates on voluntary death or euthanasia in a number of industrialized societies.

### Additional References

Baltes, P.B. & M.M. Baltes (eds)

1990 *Successful Aging: Perspectives from the Behavioral Sciences*. Cambridge: Cambridge University Press.

Foner, N.

1984 *Ages in Conflict. A Cross-Cultural Perspective on Inequality Between Old and Young*. New York: Columbia University Press.

Fry, C.L. & J. Keith (eds)

1980 *Aging in Culture and Society: Comparative Viewpoints and Strategies*. New York: Appleton-Century-Crofts.

Glascok, A.P.

1990 'By Any Other Name, It Is Still Killing: A Comparison of the Treatment of the Elderly in America and Other Societies.' In: J. Sokolovsky (ed.), *The Cultural Context of Aging*. New York: Bergin & Garvey, pp. 43-56.

Holy, L.

1990 'Strategies for Old Age Among the Berti of the Sudan.' In: P. Spencer (ed.), *Anthropology and the Riddle of the Sphinx*. London: Routledge, pp. 167-82.

Ogawa, N. & R.D. Retherford

1993 'Care of the Elderly in Japan: Changing Norms and Expectations.' *Journal of Marriage and the Family* 55: 585-97.

Rhoads Holmes, E. & L.D. Holmes

1995 *Other Cultures, Older Years*. London: Sage.

Sokolovsky, J. (ed.)

1990 *The Cultural Context of Aging*. New York: Bergin & Garvey.

Spencer, P. (ed.)

1990 *Anthropology and the Riddle of the Sphinx*. London: Routledge.

## Exercise

- 1 Discuss in groups of four the relationship between young and elderly people in your own community:
    - describe the relationship in its various forms;
    - indicate which main factors account for the quality of the relationship (e.g. respect, reciprocity, care arrangements, control over resources, etc.).
  - 2 Summarize your account in a written text of about 500 words.
-

MODULE 17

**CHILDHOOD ILLNESSES:  
DIARRHOEAL DISEASES AND ARI**

## CHILDHOOD ILLNESSES: DIARRHOEAL DISEASES AND ARI

### Objectives

At the end of this Module, participants are expected to:

- Understand the role of socio-cultural factors in the prevention and management of two of the most common causes of childhood illness: diarrhoea and acute respiratory infections (ARI);
- Be able to assess interventions for these illnesses from an anthropological perspective.



## MODULE 17A

# DIARRHOEAL DISEASES: TRANSMISSION, MANAGEMENT AND PREVENTION

## Literature

Chowdhury A.M.R. & J.P. Vaughan

1988 'Perception of Diarrhoea and the Use of a Home-made ORT Solution in Rural Bangladesh.' *Journal of Diarrhoeal Disease Research* 6 (1): 6-14.

Nichter, M.

1985 'Drink Boiled Water: A Cultural Analysis of a Health Education Message.' *Social Science & Medicine* 21 (6): 667-9.

Nichter, M.

1991 'Use of Social Science Research to Improve Epidemiological Studies of Interventions for Diarrhoea and Dysentery.' *Review of Infectious Diseases* 13: 265-71.

## Contents

- 1 Introduction
- 2 The Social and Cultural Context of Transmission and Prevention
- 3 Cultural Appropriate Management of Diarrhoeal Diseases

## 1 Introduction

Diarrhoea is a clinical syndrome associated with loose or watery stools with or without vomiting and fever. It has been a major killer disease among children in the developing world. It causes dehydration due to loss of water and electrolytes from the blood and makes patients very weak through loss of body fluids and nutrients. In extreme cases, such as in cholera, loss of body fluid can be very rapid and result in death in three to four hours. In moderate form, repeated attacks of diarrhoea can cause malnutrition among children and make them more susceptible to diarrhoeal diseases. The diarrhoea-malnutrition cycle hampers adequate growth and development. It is a disease of poverty and linked with poor water, sanitation, and living conditions. Infectious diarrhoea can be caused by viruses, bacteria and other pathogens.

## 2 The Social and Cultural Context of Transmission and Prevention

Diarrhoea is usually transmitted through the faecal-oral route, mainly through contaminated food and water. In poor societies adequate water and sanitation conditions are often lacking (see Module 19). People use surface water for drinking, washing, and bathing purposes. Surface water is very likely to be contaminated. Thus, diarrhoea is closely related to hygiene behaviour and water and sanitation practices. It can be prevented through change in hygiene behaviour, and water and sanitation practices. These behavioural practices are quite often influenced by social and cultural factors. In many societies traditionally diarrhoea is classified into many types and also is believed to be caused by various factors depending on the nature of the diarrhoea. Thus, to understand the transmission, to design preventive interventions, and to assess the impact of modern interventions it is important to understand the social and cultural context of diarrhoea.

Nichter (1991) argues that in doing research for the development and evaluation of interventions to control diarrhoea we need to identify:

- 1 local categories of diarrhoeal illness;
- 2 perceived signs of severity, which point to specific attributes such as blood and/or mucus in the stools, and the color of the stools;
- 3 local response to clinical signs of dysentery, i.e. blood in stools;
- 4 the way in which illness is spoken about (connotative aspects: the illness-related associations: feelings, fear etc.);
- 5 popular use of biomedical terms

He points out that diarrhoea control programmes have not sufficiently taken into consideration folk taxonomy of diarrhoea. People are given oversimplified messages on the use of oral rehydration therapies (ORT), while they themselves identify diarrhoea with bloody stools as serious, and are likely to medicate this condition with anti-diarrhoeal drugs.

A more culture-sensitive diarrhoea control programme would need to move beyond the focus on ORT to embrace nutritional management and the correct use of anti-diarrhoeal drugs (which are generally inessential in the treatment of childhood diar-

rhoea). Appropriate messages for effective case-management of dysenteric and other persistent and complicated diarrhoeas need to be developed to complement the ORT messages which are currently emphasized in diarrhoea control programmes.

Weiss (1988) presents a conceptual framework for the study of diarrhoeal diseases, including several concepts developed by medical anthropologists, including patterns of distress, explanatory models, patterns of health-seeking behaviour, and different treatment options. Figure 17.1 indicates each of these sets of variables, which together characterize the ‘cultural construction’ of diarrhoea. The conceptual framework organizes ethnographic findings in a manner that enables health professionals to apply them in their programmes.

**Figure 17.1** Cultural Construction of Diarrhoeal Illness: Interrelationship of Social Factors, Illness Experiences, Help-Seeking and Outcome (Source: Weiss 1988: 6)

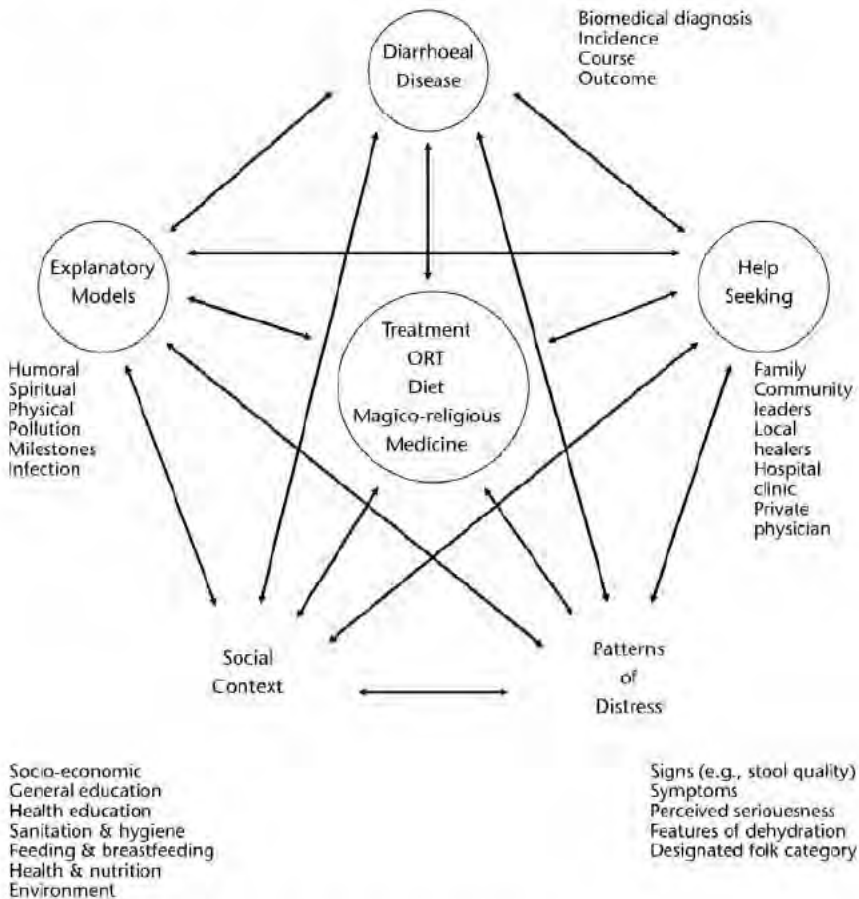

Weiss further argues that health planning for diarrhoeal diseases must be responsive to both epidemiological patterns and local perceptions of health, illness and need. Hence,

when studying diarrhoeal diseases, a combination of ethnographic and epidemiological methods is likely to be synergetic.

### 3 Cultural Appropriate Management of Diarrhoeal Diseases

Scientific management of diarrhoea involves appropriate replacement of fluid. Oral Rehydration Solution (ORS) is in fact constituted with ingredients to replace electrolytes and water in the body to prevent dehydration. If appropriately taken, it can prevent dehydration and death. If diarrhoea is caused by pathogens, an antibiotic is used side by side with ORS in cases of mild or moderate diarrhoea or an intravenous injection of saline in cases of very severe diarrhoea.

Traditionally in many societies diarrhoea was managed by drinking rice water, green coconut water and/or some other kind of drink. These have been developed into all kinds of culturally appropriate rehydration therapies (ORT) promoted in health education. Normal food including breast milk is often stopped or reduced during diarrhoeal episodes. Modern knowledge encourages drinking of fluids and continuation of normal food during diarrhoea. Thus, the promotion of modern diarrhoea management practices in the community involves targeting both community members and healthcare providers for a change in their attitude and behaviour. A knowledge of the explanatory model for diarrhoea is essential to design an effective communication strategy for behaviour change both in terms of prevention and management.

*To understand why preventive intervention has been unsuccessful for water-related diarrhoeal diseases in Sri Lanka, Nichter (1985) studied the main forms of behaviour in the spread of diseases: defaecation habits, food handling and drinking water. Regarding the advice to drink boiled water he found that this message is fully understood in the context of illness and vulnerability. Public health workers emphasized this advice during epidemics (cholera, etc), and it is associated with Ayurvedic advice to take a light diet when ill. Underscoring lay interpretations of the 'drink boiled water' message are folk health concepts; ideas about the qualities of water, shock and digestive capacity. Strong and healthy people were found to be little concerned about the water they routinely used, unless its color, smell or taste changed. When people are ill or in a transitional body state, e.g. infants and pregnant women, the qualities of water are closely noted. They will not make use of water coming from a deep well (because of its cooling qualities) or directly exposed to the sun. If this is the only water available for ill or vulnerable people to drink, then it will be boiled in an attempt to mitigate its properties.*

*'Shock' is an important health concept in Sri Lanka. It occurs when a person in a vulnerable state is subjected to an excess of hot or cold. Therefore, ill people only consume and wash with tepid water. Villagers interpret the advice to drink boiled water in relation to the concept of shock. Because villagers do not associate boiling water with killing bacteria, they place more emphasis on administering tepid water to the ill than on fully boiling it. They may boil water for the ill or vulnerable person, and then recontaminate it by adding cool unboiled water to make it tepid.*

*To be appropriate, health messages should be based on careful observation of customary behaviour and the analysis of cultural systems.*

## Additional References

- Bentley, M.E.  
1988 'The Household Management of Childhood Diarrhea in Rural North India.' *Social Science & Medicine* 27 (1): 75-85.
- Bentley, M.E. et al.  
1988 'Rapid Ethnographic Assessment: Applications in a Diarrhea Management Program.' *Social Science & Medicine* 27 (1): 107-116.
- Berih, A.A. et al.  
1988 'Pharmacy Dispensing Practices for Sudanese Children with Diarrhea.' *Public Health* 103: 455-8.
- Chowdhury, A.M.R. & Z.N. Kabir  
1991 'Folk Terminology for Diarrhoea.' *Reviews of Infectious Disease* 13 (supplement): 5252-5254.
- Chowdhury, A.M.R & R. Cash  
1996 *A Simple Solution*. Dhaka: University Press Limited.
- Eisemon, T.O. et al.  
1987 'Uses of Formal and Informal Knowledge in the Comprehension of Instructions for Oral Rehydration Therapy in Kenya.' *Social Science & Medicine* 25: 1225-34.
- Frankel, S.J. & D. Lehmann  
1985 'Oral Rehydration: What Mothers Think.' *World Health Forum* 6 (3): 271-3.
- Green, E.C.  
1986 'Diarrhea and the Social Marketing of Oral Rehydration Salts in Bangladesh.' *Social Science & Medicine* 23 (4): 357-66.
- Green, E.C.  
1999 *Indigenous Theories of Contagious Diseases*. Walnut Creek, Altamira Press/Sage.
- Mull, J.D. & D.S. Mull  
1988 'Mothers' Concepts of Childhood Diarrhea in Rural Pakistan: What ORT Program Planners Should Know.' *Social Science & Medicine* 27 (1): 53-67.
- Nations, M.K. et al.  
1988 'Brazilian Popular Healers as Effective Promoters of Oral Rehydration Therapy (ORT) and Related Child Survival Strategies.' *Bulletin of Pan American Health Organization* 22 (4): 335-54.
- Weiss, M.G.  
1988 'Cultural Models of Diarrhoeal Illness: Conceptual Framework and Review.' *Social Science & Medicine* 27 (1): 5-16.
- WHO  
1983 WHO Minimum Evaluation Procedure (MEP) in Waterlines 2 (1).

## Exercise

- 1 List the local names for various types of diarrhoea prevalent in your country. Is a distinction made between diarrhoea with blood and watery diarrhoea? What are the community perceptions about the causes of various types of diarrhoea?
  - 2 How are the various types of diarrhoea managed? What is done about breastfeeding and normal food during diarrhoea?
  - 3 How widely is ORT used to manage diarrhoea? What are the barriers to ORT use? How can these barriers be overcome?
-

# ACUTE RESPIRATORY INFECTIONS IN CHILDREN

## Literature

Ramos-Jimenez, P. et al.

1999 *Immunization in the Philippines*. Amsterdam: Het Spinhuis.

WHO

1992 *Focused Ethnographic Studies in ARI Manual*. Geneva: WHO.

## Contents

- 1 Introduction
- 2 The Development of the ARI Programme
- 3 Cultural Appropriate Management of ARI
- 4 The Social and Cultural Context of the Prevention of ARI

## 1 Introduction

Unlike diarrhoea where there is an almost universal understanding of the signs and symptoms, acute respiratory infections (ARI) cover a broad spectrum of illnesses and diseases affecting the upper, middle and lower respiratory tracts. The signs and symptoms can range from a simple cold to coughing, difficult breathing, chest pains, which may or may not be accompanied by fever, and pain in other parts of the body. There are also vast differences between the terms and groups of signs and symptoms that doctors and biomedical researchers use and the terms and groups of signs and symptoms that mothers and traditional healers use. Consequently, there is a lack of common understanding about these conditions between health providers and the community. This presented problems in 'labelling' or diagnosis, so that it was difficult to recognize the extent to which ARIs were contributing to morbidity and mortality in children until the 1970's.

## 2 The Development of the ARI Programme

It was only in 1982 that the WHO established a special programme for ARIs linked with the diarrhoea control programme (which had been in place since the early '70s). At this time, the impact of diarrhoea control had reduced diarrhoea's role as a cause of death in children and ARIs became (and still are to this day) the number one cause of death, particularly in the developing world. Following the diarrhoea control programme model, WHO patterned an ARI programme that could be applied in primary health care (PHC) contexts without diagnostic technology (Ruutu & Lucero 1994).

## 3 Cultural Appropriate Management of ARI

The most important step in the management of ARI is the recognition that the child has a problem that could be life-threatening. Coughs and colds, which may be the initial and sometimes the only manifestations, are very common in children. Mothers and caregivers around the world give home remedies for these symptoms. But when the cough is due to pneumonia caused by a bacterial infection, the condition of infants and young children (especially when they are malnourished) can deteriorate very quickly and, unless given antibiotics and special care, they may die.

Ethnographic and biomedical research have contributed to an algorithm that is today being used by WHO in ARI and Integrated Management of Childhood Illness (IMCI) programmes in developing countries, where bacterial pneumonia is a prevalent cause of ARI (WHO 1997). The algorithm guides health workers in deciding whether or not a child needs to be treated with antibiotics, whether or not the condition can be managed at home or requires special care and how to provide follow-up care. The biomedical terms in the algorithm such as 'chest indrawing' and 'difficult breathing', need to be 'translated' (i.e. taking the emic perspective of the child's caregiver) into terms to which mothers can relate. In Tagalog, these would be referred to as '*umaalon ang tiyan*



at *dibdib* ('chest and abdomen move in waves', as described by Filipino mothers upon seeing a child with chest indrawing) and '*hirap ang paghinga*', a literal translation of difficult breathing. This example shows how using terms mothers actually use can help health workers give appropriate messages to mothers on how to identify the danger signs of ARI in her child. Mothers need to know what to do when a child starts to cough or has difficulty breathing, how to recognize when she or he has developed a serious complication as soon as this occurs and how to decide when to seek care. These important steps do not take place in a health facility but in homes and they are best understood within the social and cultural contexts of families in communities.

#### 4 The Social and Cultural Context of the Prevention of ARI

The risk factors for ARI (low birth weight, malnutrition, lack of immunization, low socio-economic status and poor hygiene) are intertwined in a web of social, cultural and economic interactions that are difficult to unravel. Health workers need to understand these factors and assess how they apply to the individual mother seeking care for her sick child so that specific and pertinent advice can be provided.

ARI prevention today consists of:

- 1 managing protein-calorie malnutrition
- 2 providing Vitamin A supplementation
- 3 promoting and supporting breastfeeding
- 4 addressing indoor pollution (including smoking by adults in the household)
- 5 immunization for diphtheria, pertussis and measles that are common bacterial causes of life-threatening pneumonia.

All of these interventions require the interaction of the health system and communities and the active involvement of women and their households.

*Jimenez et al. (1999) found that while mothers' concepts of disease causation overlap with those of providers, there are concepts such as the 'hot-cold' paradigm (illustrated by the common belief among Filipino mothers that 'cold' perspiration drying on a 'hot' back causes cough and colds), that continue to influence their health practices. A folk syndrome, 'pilay', consisting of cough, colds, fever and body pains (with or without other accompanying signs or symptoms) is believed to be naturally occurring and is therefore part of life. 'Pilay' responds to 'hilot', a form of traditional massage, while dried perspiration is treated with traditional herbs. Mothers are afraid to expose children sick with measles to 'cold' air or water, or to give them certain kinds of foods as these would 'prevent the rashes from coming out' ('lulubog ang tigdás' in Tagalog) and the child will die.*

These folk ideas on ARI causation need to be considered in developing community-based ARI-control programmes.

## Additional References

Ruutu, P. and M. Lucero

1994 'Respiratory Infections.' In: K.S. Lankinen et al. (eds), *Health and Disease in Developing Countries*, pp. 125-134.

WHO

1997 'Division of Child Health & Development. Integrated Management of Childhood Illness: Conclusions.' *Bulletin of the WHO* (suppl 1), vol. 75: 119-128.

---

## Exercises

### *Individual Work*

Construct an explanatory model for pneumonia in your own community, comparing a mother's perception and a health provider's perception of how it is caused and how it should be managed. Discuss how any differences could affect how a child with pneumonia would be cared for (create possible scenarios) and how a health officer in the community would address this.

### *Small group work*

Select an intervention for ARI prevention and develop a community-based programme. Identify the key players in your intervention and describe in detail the roles that each is expected to play. What factors would you consider to increase the likelihood of the programme's success?

---

**MODULE 18**

**FOOD, HEALTH AND CULTURE**

# FOOD, HEALTH AND CULTURE

## Objectives

At the end of this module, participants are expected to:

- appreciate the various contexts in which food and health exist;
- be able to describe the meanings of food and how these affect the complex interactions between food and health.

## Literature

Helman, Cecil G.

2000 'Diet and Nutrition.' *Culture, Health and Illness*. 4<sup>th</sup> edition. Ch. 3.  
Reed Educational and Professional Publishing Ltd.

Pelto, G. et al.

2000 'The Biocultural Perspective in Nutritional Anthropology.' In:  
A. Goodman et al. (eds), *Nutritional Anthropology*, pp. 1-9.

## Contents

- 1 Introduction
- 2 Food for Survival
- 3 Food for Health
- 4 Food as Medicine

## 1 Introduction

Food evokes as many meanings as there are people in this world. Even at various moments in a day, one may regard it as essential, as comfort, as escape, as reward (or punishment), as safety and even as a burden. Throughout humanity's existence, much of people's time and effort has been spent in securing food, preparing it, and partaking of it. Our most elemental rituals and social interactions deal in some way, often principally, with food. Small wonder then that upon exposure to another culture, our first and often most lasting memories are of its food.

There are wide variations across cultures in defining what is and is not food, rules on who prepares which foods for whom, patterns of consumption according to attributes such as gender, social class, and age. There are 'sacred' and 'profane' foods; foods that belong together and some that should never be combined. There are appropriate seasons, times of day, and periods within one's life cycle when certain foods can be eaten and others cannot. Foods are given as gifts to mark celebrations and define kinship ties and are offered to the gods. Foods give life and can also cause death.

Our focus for this module is on one dimension of food, which is its role in human health, as viewed from a bio-cultural perspective (Pelto et al. 2000). Three contexts are highlighted: 1) food for survival and how changing food production systems affect health and nutrition, 2) food for health and how cultural and economic factors affect food choices and lead to nutritional problems, and 3) food as medicine, where an ancient and complex traditional healing system illustrates the use of food for the treatment of illness.

## 2 Food for Survival

Goodman and Armelagos (2000), who are physical anthropologists, studied the archeological remains of a hunting-gathering society that was making its transition to agriculture. Based on evidence from bone remains, they found that those who lived pre-transition had fewer signs of disease and poor nutrition and lived longer. The authors question the 'agricultural hypothesis', i.e. population pressure resulting in food shortages and declining health leading to the shift in agriculture, as being an explanation for the health changes seen in these skeletal remains. These anthropologists postulate that as the community became more productive, they began to accumulate surplus and to trade with neighbouring groups. Internal strife may have occurred as stratification developed within this society, and those who had less developed anemia and other signs of deficiency. These events mirror parallel transitions in our more contemporary underdeveloped countries. As people become more dependent on cash crops and products, they abandon traditional food sources and ways of production and experience unbalanced diets and consequent malnutrition (Kuhnlein & Receveur 1996).

### 3 Food for Health

Shifting food production patterns are among the reasons for developing deficiencies but they are by no means the only ones. Cultural practices, household allocation and individual food preferences all play a role as well. Creed-Kanashiro (1997) looks at these factors in Peru, comparing a rural and an urban community. Using some rapid assessment ethnographic techniques designed for assessing Vitamin A deficiency, she found that Vitamin A intake was much lower in the rural area, attributing this to the season when the study was conducted as well as the lack of access to alternative sources of food. Infants are dependent on breast milk for their Vitamin A needs and are at risk for deficiency during the weaning period as child-feeding is 'extremely passive', with mothers responding only to perceived demands of the child for food. She concludes that since Vitamin A-rich sources are available, it is possible to modify consumption patterns to address this vitamin deficiency.

### 4 Food as Medicine

Another reality food plays in human life is when it is taken as a cure for an illness. Traditional medicine systems – Ayurvedic, Unani, Chinese, Greco-Ionian, among others – all have some dietary prescription as a component of treatment. Increasingly, biomedical practitioners are also considering nutritional aspects when managing disease conditions.

In his book chapter 'Chinese nutritional therapy', Anderson (2000) describes a complex system of food beliefs and practices that have evolved from millennia of empirical use. For the Chinese, all foods have some medicinal value. Their food consumption is not guided by a nutritional food pyramid, but by explanations related to *qi* (the Chinese concept that defines a universal form of energy), the balance between *yin* and *yang* and between 'hot' and 'cold'. This integration of philosophical thought, religious beliefs and day-to-day pragmatic decisions related to food have provided guidelines for food choices that have sustained the Chinese people for thousands of years. The most salient feature of this tradition is that the locus of control in the development of an illness is in the individual. Illness is not something that comes from the outside, but from the body's inability to cope with the external insult. Nutrition is a way to strengthen the body to overcome this insult.

Beyond the individual, in an increasingly globalized world, external forces that influence food production, distribution, and consumption affect food choices and ultimately their effect on nutrition and health. Peltó and Peltó (2000) review dietary changes over the last quarter of the millennium and trace events to trade and commerce, migration and 'modernization', illustrating consequences on diet. The 'fast food culture' and the proliferation of 'junk foods' and their effects on the nutrition of people in developed countries is fast encroaching on the rest of the world, driven by cross-cultural access, ease of travel and global marketing (and profit-making) strategies. Food manufacturers increasingly market their products by pointing to health benefits and by adding pharmaceutical ingredients to substantiate the health claims. As we move closer and closer to being one global community, 'delocalization' changes the

way we eat, our nutrition and our health. Are we likely then to lose the rich diversity in food choice that humans have enjoyed and in the process suffer from the same nutritional consequences of this change? Or will delocalization enrich individual food systems and bring about a more equitable distribution of nutritional resources for better 'health for all'?

### Additional References

Anderson, E.

- 2000 'Chinese Nutritional Therapy.' In: A. Goodman et al. (eds), *Nutritional Anthropology: Bio-Cultural Perspectives on Food and Nutrition*, pp. 198-212. Mountain View: Mayfield Publishing Company.

Creed-Kanashiro, H.

- 1997 'Peru: The Rural Community of Chamis and the Urban Suburb of San Vicente in Cajamarca.' In: H. Kuhnlein & G. Peltó (eds), *Culture, Environment and Food to Prevent Vitamin A Deficiency*. Boston: INFDC.

Goodman, A & G. Armelagos

- 2000 'Disease and Death at Dr. Dickson's Mounds.' In: A. Goodman et al. (eds), *Nutritional Anthropology*, pp. 58-62. Mountain View: Mayfield Publishing Company.

Kuhnlein, H. & O. Receveur

- 1996 'Dietary Change and Traditional Food Systems of Indigenous Peoples.' *Annual Review of Nutrition* 16: 417-42.

Peltó, G. & P. Peltó

- 2000 'Diet and Delocalization: Dietary Changes Since 1750.' In: A. Goodman et al. (eds), *Nutritional Anthropology*, pp. 269-278.

## Exercises

- 1 Think about what you ate yesterday. What made you choose those foods? How different are your food habits now from when you were growing up as a young child? What socio-cultural and macro forces have influenced these differences in your food practices? Write these answers in the form of lists, as an individual exercise.
  - 2 As a group exercise, discuss the most common nutritional problems in your countries/communities. What socio-cultural factors contribute to this problem or could be harnessed to help solve it? Make a brief summary of your discussion for presentation in class (10-15 min).
-



**HYGIENE, WATER AND SANITATION**

# HYGIENE, WATER AND SANITATION

## Objectives

At the end of this Module, the participants should be able to:

- identify and study the social and cultural context of water and sanitation;
- incorporate a social and cultural perspective in designing and evaluating water and sanitation intervention.

## Literature

Curtis, V.

- 1998 'Body Boundaries and Invisible Monsters: The Social Significance of Hygiene.' In: V. Curtis, *The Dangers of Dirt: Household Hygiene and Health*. (PhD Thesis), Agricultural University, Wageningen, pp. 11-42.

Simpson-Hebert, M.

- 1984 'Water and Sanitation: Cultural Considerations.' In: P.G. Bourne (ed.), *Water and Sanitation: Economic and Sociological Perspectives*. Orlando: Academic Press, pp. 173-198.

## Contents

- 1 Cultural Perceptions of Dirt and Cleanliness
- 2 Water
  - Biomedical perspective*
  - Social and cultural aspects*
- 3 Sanitation
  - Biomedical perspective*
  - Social and cultural aspects*

## 1 Cultural Perceptions of Dirt and Cleanliness

People in all cultures have ideas about dirt and cleanliness. These ideas usually take a central place in their cosmological and moral world. Concepts of good and evil, right and wrong, safe and dangerous, tend to be closely linked to perceptions of dirty and clean. Mary Douglas (1966) has pointed out that ‘dirt’ does not refer to substance as such, but to the place of that substance in people’s lives. Her famous dictum goes: Dirt is matter out of place. Dirt, in other words, is disorder. Order is not nature-given; it always is the outcome of human making that can vary enormously. What is order (and ‘clean’) in one place can be disorder (and ‘dirty’) elsewhere. ‘Dirt’, therefore, does not exist in absolute terms, it exists in the eye of the beholder.

Douglas distances herself from what she calls ‘medical materialism’, the claim that concepts of purity and dirt derive from an age-old medical knowledge. In her opinion, the concept of dirt helps people to put their lives in order. It is a tool to classify people, objects and events in positive and negative terms. Biomedical concepts of hygiene do not always easily go along with indigenous cultural perceptions of cleanliness. Policy-makers and health workers should keep this in mind.

## 2 Water

### *Biomedical Perspective*

It is impossible to think of life without water. Human beings have been exploiting surface, rain, and ground water sources for various purposes from time immemorial. Use of water in drinking and maintaining health and personal hygiene is very important. Health is affected by the ingestion of contaminated water either directly or through food (see Module 17 on diarrhoeal diseases). Common health problems caused by the presence of infective agents in water include viral hepatitis, poliomyelitis, diarrhoeal diseases, typhoid, giardiasis, and worm infestation. Chemically contaminated water can cause non-infectious degenerative disorders.

Usually water contains natural impurities and contaminants derived from the atmosphere. The most serious contamination is caused by the consequence of various human activities. Sewage contains pathogenic agents, industrial wastes contain toxic agents, and chemical fertilizers contain harmful chemicals. In the developing world, waste disposal is very poor and quite often contaminates the water sources. There are also examples of ground water contamination by arsenic, fluoride or other similar toxic metals. Availability of water also varies by geographical areas – some countries do not have enough and others are inundated by water seasonally which often is highly contaminated, both having negative health consequences. Water, which is safe at source, may also be contaminated while being carried and/or by the way it is stored. Thus, water needs to be purified either by filtration, boiling, or chemical treatment before use. In developed countries the purification is done centrally by the water supply system. The rural areas and urban slums in the developing world are often outside the piped water supply system.

### *Social and Cultural Aspects*

The appreciation of water is influenced by cultural notions and its collection and storage is subject to social norms and power relationships. Burghart (1988) writes that people in Nepal evaluated the quality of water by criteria that were quite different from those of the municipal authorities. Misra (1975) lists seven reasons why people in an Indian community preferred water from the wells to pipe-borne water. Water may have a religious meaning or represent other values that may be irrelevant to public health professionals.

Water also has strong social and political connections that should be taken into account by policy-makers. A society may, for example, have strict rules about who should – and who should not – collect water.

## 3 Sanitation

### *Biomedical Perspective*

Sanitation is the establishment of conditions favourable to health. One of the most crucial conditions enhancing health and preventing disease is the safe disposal of human waste. Waste disposal, which is a matter of public concern, is usually organized at the level of the community. It involves the enforcement of certain rules, providing some kind of garbage collection and – in rich countries – building a water and sewerage system. But sanitation also includes personal hygiene. Keeping the house and its surroundings clean, particularly the kitchen, using soap to clean the body and clothes and washing hands after defecation. Observance of strict personal hygiene measures controls – to a certain extent – the transmission of communicable diseases.

### *Social and Cultural Aspects*

The management of dirt is an integral part of all cultures but conceptions of dirt and ways of dealing with it vary starkly between and within cultures (cf. Curtis 1988). Human defecation is a case in point. The place of defecation can be an open field, a beach, a pit at the outskirts of the village, a private latrine in the house, ranging from pit and bucket to water closet and a public toilet. Human faeces are regarded with great disgust and fear in one culture but used as manure in another. There is, moreover, a strong differentiation in the degree of perceived 'dirtiness'. People usually regard their own and their young children's faeces as less disgusting than those of others.

Human defecation is often surrounded by taboos and elaborate rules of etiquette, which render sanitation interventions complex and delicate. Reports about failing attempts to improve sanitary behaviour abound. There is still a great lack of knowledge and understanding of cultural habits around defecation. In spite of their interest in dirt and pollution as theoretical issues, anthropologists have largely neglected defecation in their ethnographic work. Better understanding of this more hidden part of human culture is indispensable if we want to improve sanitation in local communities (cf. Almedon 1996, Aziz et al. 1994, Curtis 1998, Green 1999, Stanton et al. 1987).

## References

- Almedom, A.M.  
1996 'Recent Developments in Hygiene Behaviour Research: An Emphasis on Methods and Meaning.' *Tropical Medicine and International Health* 1 (2): 171-82.
- Aziz, K.M.A. et al.  
1994 *Recent Contributions of Behavioural and Biomedical Scientists in Applied Anthropology of Hygiene Practices and Management of Diarrhoea in Bangladesh* 9 (4): 309-316.
- Burghart, R.  
1988 'Cultural Knowledge of Hygiene and Sanitation as a Basis for Health Development in Nepal.' *Contributions to Nepalese Studies* 15 (2): 185-211.
- Curtis, V.  
1998 *The Dangers of Dirt: Household Hygiene and Health*. (PhD Thesis), Agricultural University, Wageningen.
- Douglas, M.  
1966 *Purity and Danger. An Analysis of Concepts of Pollution and Taboo*. Harmondsworth: Penguin.
- Green, E.C.  
1999 *Indigenous Theories of Contagious Disease*. Walnut Creek, etc.: Altamira Press/Sage.
- Misra, K.K.  
1975 'Safe Water in Rural Areas: An Experiment in Promoting Community Participation in India.' *International Journal of Health Education* 18 (1): 53-59.
- Stanton B.F. et al.  
1987 'An Educational Intervention for Altering Water-Sanitation Behaviours to Reduce Childhood Diarrhoea in Urban Bangladesh: Formulation, Preparation and Delivery of Educational Intervention.' *Social Science & Medicine* 24 (3): 275-83.

## Exercise

Discuss the following questions in small groups:

- 1 What are the two most dirty things in your societies?
  - 2 Why are they regarded as dirty?
  - 3 How do people deal with this dirt?
  - 4 What are the health consequences of this management of dirt (provide emic and etic perspectives)?
-

**MODULE 20**

**CULTURE AND MENTAL HEALTH**

# CULTURE AND MENTAL HEALTH

## Objectives

At the end of this module, the participants should be able to:

- describe the role of culture in relation to mental health;
- understand the relationship between the social context and mental health;
- point out in what way social science research may contribute to mental health policies and programmes.

## Literature

Janzen, J.

- 1999 'Text and Context in the Anthropology of War Trauma: The African Great Lakes Region 1993-95.' *Suomen Antropologi* 4: 37-57.

Kleinman, A. & B. Good (eds)

- 1985 *Culture and Depression: Studies in the Anthropology and Cross-cultural Psychiatry of Affect and Disorder*. Berkeley: University of California Press (recommended).

Littlewood, R.

- 1996 'Comments on Culture-bound Syndromes.' In: J. Mezzich et al. (eds.), *Culture and Diagnosis: A DSM-IV Perspective*. Washington, DC: American Psychiatric Press, pp. 253-273.

Swartz, L.

- 1998 *Culture and Mental Health. A Southern African View*. Cape Town: Oxford University Press.

## Contents

- 1 Mental Health in the World
- 2 Mental Health in Cultural Perspective



## 1 Mental Health in the World

Mental health problems are among the most significant contributors to the global burden of disease.

---

‘Some 500 million people in the world suffer from mental or neurological disorders or from psychosocial problems such as those related to alcohol and drug abuse. Of every four people who turn to the health services for help, at least one is troubled by these disorders which are often incorrectly diagnosed and thus not treated’ (WHO 2000).

---

Mental health problems are often a result of complex and multiple biological, psychological and social factors (e.g. war, poverty), and it is believed that the burden of these problems is to become heavier in the coming decades and will raise obstacles to global development. Substantive action is necessary.

The question of where to draw the boundaries around the concept of mental health is important. Some say that mental health issues only relate to disorders which are defined by the *Diagnostic and Statistical Manual* of the American Psychiatric Association. Others say that mental health must be more broadly defined in relation to a variety of problems (violence, poverty, dislocation, substance abuse, oppression). The World Health Organization proposed a view of health as a positive state of physical, mental and social well-being. Mental health is part of health in general. However, the concept of mental health may vary across cultures and groups. What psychiatry might consider as a mental health problem, religious groups see as a spiritual one.

A broad definition of mental health will incorporate groups that are at special risk of developing and having mental health problems: people living in poverty, abused women, abandoned elderly, migrants, refugees, and children. Mental health problems have received lower priority than communicable diseases, but mental problems now are defined as an important burden of disease (WHO, factsheet 217), and as such seem to be receiving more attention from health planners.

## 2 Mental Health in Cultural Perspective

Cultural knowledge about mental illness is embedded in a conceptual universe and includes a wide range of ideas about the person, the self and social behaviour. Culture is dynamic:

---

‘Cultural psychology is the study of the ways subject and object, self and other, psyche and culture, person and context, figure and ground, practitioner and practice live together, require each other, and dynamically, dialectically and jointly make each other up’ (Shweder 1990: 1).

---

A range of views exists on mental health and culture which can be grouped into three main approaches: universalism, relativism and critical approaches. Few researchers keep to one approach. The universalist approach understands mental illness as universal and looks cross-culturally to find evidence for the universals. The approach recognizes the different ways of talking about mental illness, but tends to use the Western diagnostic system as a standard and believes that psychiatry has discovered core syndromes with different manifestations in different parts of the world. A major study in this field is the International Pilot Study of Schizophrenia (WHO 1973, 1979).

The relativistic approach stresses the different ways of understanding mental suffering and the lived experience of suffering. There is more emphasis on what is happening locally than on making broad cross-cultural comparisons. Relativists argue that the Western diagnostic systems are themselves cultural products. In trying to understand mental suffering, relativists try to gain by a hermeneutic approach as full a picture as possible of the suffering's meaning in the context of the individual's family, community and spiritual world. Major contributions to this approach have been made by Kleinman (1980, 1988).

The critical approach to mental health and culture stresses the question of why knowledge is produced and in whose interests. The aim is not simply to explore cultural factors in mental health, but also to explore issues such as the effects the individual experiences from oppression, racism, sexism, and oppressive international and local socio-economic processes from the point of view of the oppressed. The approach also tries to show how psychiatry and psychology have contributed to oppressive practices (Littlewood & Lipsedge 1996; Fanon 1970; Young 1995).

Social science studies a wide variety of processes and phenomena in the field of mental health. An important contribution of the social sciences to mental health research is the outline for cultural formulation and the glossary of cultural terms (culture-bound syndromes) in the *Diagnostic and Statistical Manual IV*. Recent research focuses on cases of mental illness that are seen in community clinics that serve the poor and disadvantaged (minority casebook).

## Additional References

- Littlewood, R. & R. Lipsedge  
 1997 *Aliens and Alienists: Ethnic Minorities and Psychiatry*. London: Routledge.
- Fanon, F.  
 1970 *Black Skin, White Masks*. London: Paladin.
- Kleinman, A.  
 1980 *Patients and Healers in the Context of Culture*. Berkeley: University of California Press.
- Kleinman, A.  
 1988 *Rethinking Psychiatry: From Cultural Category to Personal Experience*. New York: Free Press.
- Young, A.  
 1995 *The Harmony of Illusions: Inventing Post Traumatic Stress Disorder*. Princeton, New Jersey: Princeton University Press.

---

## Exercise

Read the article of Janzen (1999): Text and Context in the Anthropology of War Trauma.

Discuss the following questions together:

- 1 What does the author mean by textual and contextual directions in the anthropological study of violence and trauma?
  - 2 What does the author mean by demedicalization of trauma?
  - 3 What does the author suggest instead of the medical approach and how should this be done?
  - 4 How is the analysis done and what are the imperatives for action?
  - 5 Give your comments on the conclusion.
-



**MODULE 21**

**INTRODUCTION TO  
APPLIED HEALTH RESEARCH**

# INTRODUCTION TO APPLIED HEALTH RESEARCH

## Objectives

At the end of this Module, the participants should be able to:

- describe the major characteristics of Applied Health Research;
- understand the various components of the health system;
- describe the kind of information needed for decision-making in health programmes and the contribution anthropology can make in providing such information.

## Contents

- 1 What is Applied Health Research?
- 2 Selectivity vs. Comprehensiveness in Applied Health Research
- 3 Who Should Be Involved in Applied Health Research?
- 4 Who Benefits?
- 5 Applied Health Research Methodology

Annex 21.1 Guidelines for Applied Health Research

Annex 21.2 Steps in the Development of an AHR Proposal

\* Adapted from Module 2, Health Systems Research Training Series, Volume 2

## 1 What is Applied Health Research?

---

RESEARCH is the systematic collection, analysis, and interpretation of data to answer a certain question or solve a problem.

---

The anthropological approach to Applied Health Research (AHR) is characterized by:

- a clear statement of the problem;
- the identification of the socio-cultural and economic factors that are associated with the problem;
- a plan for data collection related to the problem;
- building on existing data, using both positive and negative findings.

In identifying socio-cultural aspects of the problem, one should also try to understand how the identified health problem is related to the various components of the local health system, which, as put forward in Module 4, includes the professional, folk and popular sector.

---

A HEALTH SYSTEM may be described as:

- the health promoting and health care *practices* that occur in the professional, folk and popular sector in a specific socio-cultural setting;
  - a set of cultural *beliefs of illness and health* which forms the basis for health promoting and health care behaviour in the professional, folk and popular sector;
  - the specific health care and community *institutions* (for example the health centres and households) within which that behaviour occurs;
  - relevant *contextual factors* that determine people's health seeking practices, and the provision of health care services in the various institutions.
- 

How well the different components of the health system function depends to a large extent on socio-economic, political, cultural, physical, epidemiological, and other contextual factors. For example, economic booms or depressions will affect the health and nutritional status of individuals as well as the national budget available for health services. In Applied Health Research, one should therefore aim at clarifying the relevant context of the problem.

## 2 Selectivity vs. Comprehensiveness in Applied Health Research

Because Applied Health Research is problem-oriented, it should ideally be *selective* and concentrate on those factors that will help to explain and solve the problem being examined. In designing the study, researchers should assess how much they know about the problem. Often, it is advisable to start with an *exploratory phase* of the study,

during which the researcher identifies the socio-cultural and health factors that are related to the problem and that need further exploration.

It is important to realize that problems can be defined from different theoretical perspectives (see Module 3). Also, different levels within the health system have different priorities and perspectives and may raise different types of questions. For example, in the control of acute respiratory infections:

*National health policy-makers may want to know:*

- How can trends in national statistics of morbidity and mortality of respiratory infections be explained?
- How adequate are acute respiratory infections diagnosed and treated in health centres; to what extent are pneumonia cases left untreated; and how often are they treated inappropriately?

*Managers at district/provincial level may raise questions such as:*

- How can differences in morbidity and mortality of respiratory infections between various districts be explained?
- Do people in the communities understand when they should bring a child with a acute respiratory infection to the health centre? Do they recognize the severity signs (such as fast-breathing and drawing in of the chest)?

*Hospital directors may ask:*

- Why do we observe such a high rate of complications in acute respiratory illness? Are the first-line services sufficiently available and adequate? Are our own services adequate? Are patients delaying treatment and, if so, why?

*Managers at village level (village health committees and village health workers) may want to know:*

- Why do people not consult community health workers when they have symptoms such as a cough?
- How can we assist illiterate women in effectively preventing and treating acute respiratory illness?

*Community leaders may want to know:*

- What will be the effects of a cost-recovery program on drug costs and availability of drugs?

*(Please add your own examples)*

Problems at one level of the health system are usually connected with problems or deficiencies at other levels. Applied Health Research should address problems from the different perspectives of all those who are, directly or indirectly, involved. Otherwise we run the risk of coming up with results that only partly explain the problem and that are, therefore, insufficient to solve it.



The questions raised by the various actors involved may vary. Some are largely medical ('how appropriate is diagnosis and treatment'); others deal with socio-cultural issues ('how do people perceive severity indicators of acute respiratory infections'). Applied Health Research often requires *inter-disciplinary research*.

### 3 Who Should Be Involved in Applied Health Research?

The *participatory nature* of Applied Health Research is one of its major characteristics. To ensure that the research is relevant and appropriate, everyone directly concerned with a particular health or health care problem should be involved in the research project. This could include policy-makers, staff members from the health services involved, private health care providers, professional researchers, and the community itself. This involvement is critical if the research activities are to make a difference:

- If decision-makers are involved only after completion of the study, the report may just be shelved.
- If health care providers are involved only in data collection and not in the development of the proposal or in data analysis, they may not be motivated to collect accurate data or carry out the recommendations.
- If the community is only requested to respond to a questionnaire, the recommendations from the study may not be acceptable.
- If professional researchers are not involved in the implementation of recommendations, they may have little concern for the feasibility of the recommendations.

The roles that various types of personnel will play in the research project will depend on the level and complexity of the particular study, as well as its area of focus. Some projects are very complex and may need expertise from several disciplines (inter-disciplinary research). Others may focus on simpler problems. It is important to make clear decisions on who is responsible for what.

By dividing the study into smaller sub-studies to be conducted by the various types of personnel much ground can be covered in a short time frame. Such an approach also facilitates the management of the project, as people with very different perspectives on the problem at hand work together on the various aspects of the problem. In presenting the results, the various aspects of and perspectives on the problem are clarified, and recommendations for action made.

### 4 Who Benefits?

Participatory research means working with people with different perspectives. It also means working with people who have different interests and power positions. In designing the study, the researchers should realize these facts and analyze who will benefit from the results of the study. Ideally, people who have least power to shape health care, i.e. the health care beneficiaries, should benefit most from the research. A problem is, however, that the focus of an Applied Health study is often defined by national health policy-makers.

*Policy-makers may consider the transmission of HIV a major problem and commission a study on people's sexual behaviour and on seroprevalence of HIV in order to assess which groups are most at risk of HIV infection. In this case one could question whether the research subjects actually benefit from research. The research subjects may discover that they are infected with HIV and be confronted with the anxiety of an almost certain premature death. It may not be in their own interest to participate in the study, especially if they are not involved in defining the problem, or in deciding what is to be done with the results.*

Not only are these differences in interests and power between health policy-makers, health workers, and the beneficiaries of health care, there could also be differences in power and interests *within* the communities covered by health care services. The researchers should be aware of the local political and social structures in order to understand who are the power figures in the local context.

How can the research benefit the population? Firstly, research could encourage the participation of community members as has been described above. The reality of the situation is that a researcher will often have to work with intermediaries, such as community health workers, or local leaders. Secondly, the researchers should both feed back their results to the communities in which the research was conducted and encourage community members to formulate their own recommendations for action.

## 5 Applied Health Research Methodology

In Figure 21.1 we present an overview of the steps to take in the development of an AHR Proposal. (See also Annex 21.2 for a detailed framework for Applied Health Research Methodology). During this course you will use this framework to develop your research proposal.

**Figure 21.1** Applied Health Research Methodology\*

<i>Questions you should ask</i>		<i>Components of Research Design</i>
1	What is the problem and why should it be studied?	Statement of the problem (Module 22)
2	What questions are we trying to answer?	Definition of research questions (Module 22)
3	What information is already available?	Literature review (Module 23)
4	How do we select an appropriate study type?	Selection of study types and designs (Module 24)
5	What information do we need?	Selection of variables (Module 25)
6	What tools do we need to collect data?	Selection of data collection techniques (Module 26: Overview) (Module 27 & 28: Qualitative techniques) (Module 29: Quantitative techniques)

<i>Questions you should ask</i>	<i>Components of Research Design</i>
7 Where could we collect data?	Sampling (Module 30)
8 Are we likely to harm anyone as a result of the study?	Ethics (Module 31)
9 How is this data to be collected?	Plan for data collection (Module 32)
10 How can we determine whether our methods for data collection are correct before implementing the study?	Pretesting the methodology (Module 33)
11 What will we do with the collected data?	Plan for data processing and analysis (Module 35: Plan) (Module 36: Analysis of qualitative data) (Module 37: Computer Assisted Analysis of qualitative data) (Module 38: Analysis of quantitative data)

\* Adapted from Module 7, Health System Research Training Series, Volume 2

Note: The steps are interrelated. The process is often cyclical in nature. After completing a step, it is useful to review previous steps to ensure consistency in your proposal.

## References

Foster, G.M. & B.G. Anderson  
1978 *Medical Anthropology*. New York: John Wiley.

## Annex 21.1 Guidelines for Applied Health Research

Bearing in mind that AHR is undertaken primarily to provide information to support the decision-making process aimed at improving the functioning of the health system, we will summarize here some essential guidelines for such research to be effective:

- 1 It should focus on priority problems.
- 2 It should be action-oriented, i.e. aimed at developing solutions.
- 3 The research should be participatory in nature, involving all parties concerned (from policy-makers to community members) in all stages of the project.
- 4 Studies should be scheduled in such a way that results will be available when needed for key decisions, i.e. research must be timely. Otherwise, the research loses its purpose.
- 5 Emphasis should be placed on comparatively simple, short-term research designs that are likely to yield practical results relatively quickly. Simple but effective research designs are difficult to develop, but are much more likely to yield useful results when needed.
- 6 The principle of cost-effectiveness is important in the selection of research projects. Programme management and operational research should focus, to a large extent, on low-cost studies.
- 7 Results should be presented in formats most useful for administrators, decision-makers, and the community. Each report should include:
  - a clear presentation of results with a summary of the major findings adapted to the interests of the party being targeted by the report;
  - an honest discussion on practical or methodological problems that could have affected the findings;
  - alternative courses of action that could follow from the results and the advantages and drawbacks of each.
- 8 Evaluation of the research undertaken should not be a measure of the number of papers published but of its ability to influence policy, improve services, and ultimately lead to better health.

## Annex 21.2 Steps in the Development of an Applied Health Research Proposal

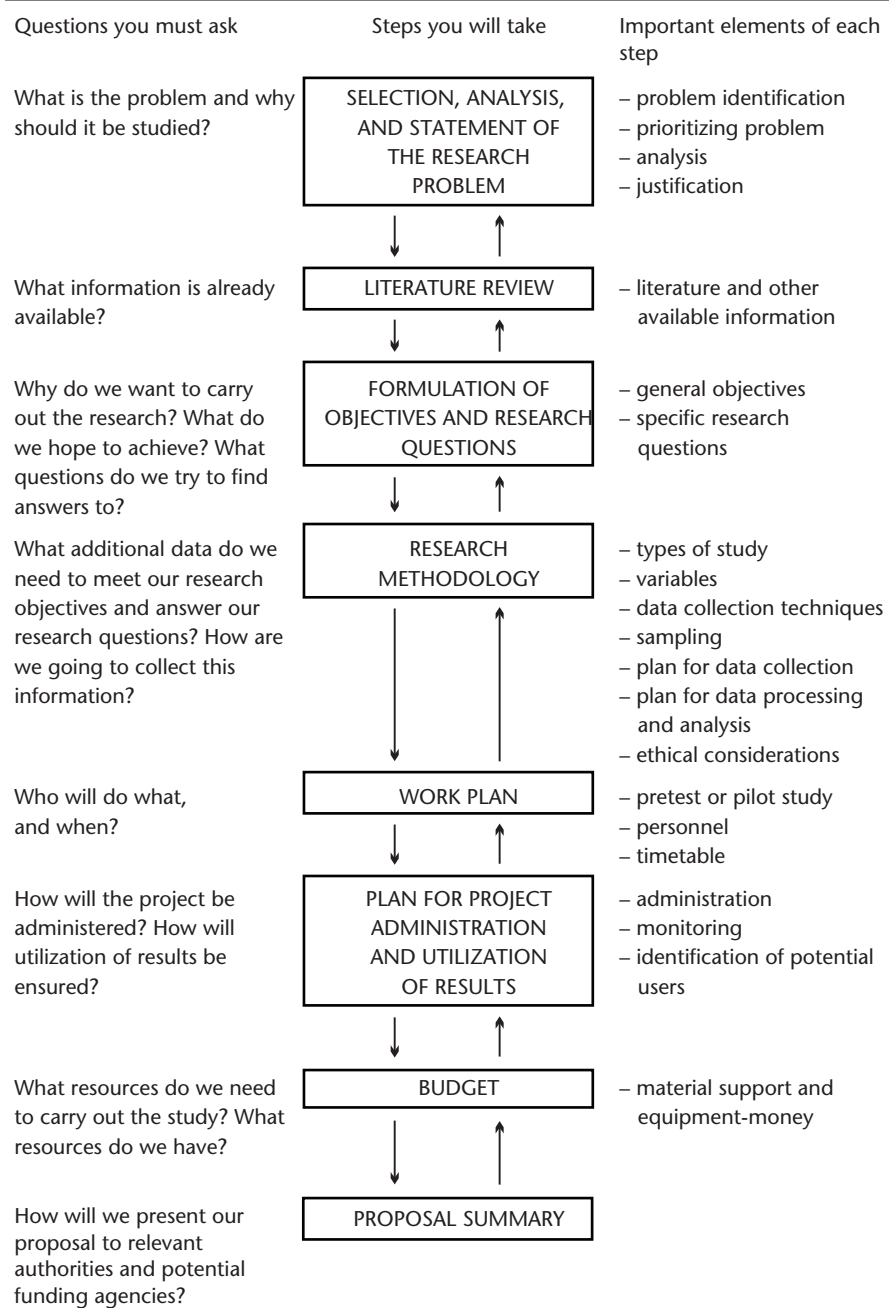

N.B. Development of a research proposal is often a cyclical process. As the arrows indicate, the process is not always linear.



**ANALYSIS AND STATEMENT OF THE PROBLEM:  
DEFINITION OF RESEARCH QUESTIONS**

# ANALYSIS AND STATEMENT OF THE PROBLEM: DEFINITION OF RESEARCH QUESTIONS

## Objectives

At the end of this Module, the participants should be able to:

- analyze a selected research problem or research topic, and the factors influencing it;
- prepare the statement of the problem for the research proposal being developed during the course;
- formulate research objectives and research questions.

## Contents

- 1 Analyzing the Research Problem or Topic
- 2 Deciding on the Scope and Focus of the Research
- 3 Formulating the Problem Statement
- 4 Formulating Objectives and Research Questions

\* Adapted from Modules 4 and 5, Health Systems Research Training Series, Volume 2



## 1 Analyzing the Research Problem or Topic

In Applied Health Research, the researcher is often required to do research on a problem with which she or he is not very familiar. Health workers and managers or community members may be much more familiar with the problem. But even they may never have given critical attention to its various aspects.

A systematic *analysis of the problem*, completed jointly by the researchers, health workers, managers and community representatives is a crucial step in designing the research because:

- it enables those concerned to pool their knowledge of the problem;
- it clarifies the problem and the possible factors that may be contributing to it;
- it facilitates decisions concerning the focus and scope of the research.

In some cases, especially in training situations where students must develop a proposal or design a study in a relatively short period of time, for pragmatic and practical reasons they may select a research *topic*, based on their personal or a theoretical interest. Such a research topic is not necessarily a priority problem from the perspective of health staff, the community or policy-makers, as described in the previous module. When designing a study proposal, the analysis of such a research topic should progress in the same way as a directly applied research problem. In the analysis of a more theoretically based research topic, information might be collected through a literature review and through contacts with some key informants and other researchers, rather than through discussions with people directly involved.

### *Steps in Analyzing a Research Problem or Research Topic*

#### *Step 1 Literature review*

A literature review during the study protocol design phase aims at finding out if others have studied the problem, and if so, where and how it was studied, and what results were found. Case studies in different regions show how the problem took shape in varying socio-cultural contexts. The researcher may become aware that factors found to be related to the research problem or topic in other cultural contexts, might also play a role in her or his own study area. It may also help the researcher to analyze the problem using theoretical insights and concepts. Moreover, the description of the methods used in other studies, and reflections on their limitations and advantages may inspire the researcher developing her or his own research proposal, e.g.: what study design to select; how to develop research tools; and how to sample and contact informants.

How to do a literature review will be described in Module 23.

#### *Step 2 Clarify the viewpoints of managers, health workers, community members and researchers in relation to the problem*

Areas of concern within the health system are often expressed in broad or vague terms by managers, health workers and community members. During initial discussions with those involved in the problem area, clarify the issues by listing all the problems in the area of concern as they perceive them (the emic approach).

Remember that a problem exists when there is a discrepancy between ‘what is’ and ‘what should be’. Therefore, the perceived problems should be worded in such a way as to illustrate this discrepancy. The problem may also be perceived differently by the different persons involved.

*For example, health care managers and health workers may determine the following problems:*

- *Insufficient awareness of appropriate drug use among patients and their relatives;*
- *Insufficient supply of drugs to government health services in the periphery;*
- *Ample availability of a wide range of inappropriate drugs in the private sector;*
- *Inappropriate dispensing practices by drugstore owners;*
- *Poor compliance of patients with prescribed therapy.*

*While community members may define the scarce availability of affordable drugs as their major concern.*

### *Step 3 Further specify and describe the problem*

One should then try to identify the most important problem: the core problem. Looking at the example discussed in Step 2, one may decide that the core problem is the inappropriate use of drugs among consumers.

One should attempt to describe it more elaborately:

- the nature of the problem; the discrepancy between ‘what is’ and what one prefers the situation to be, in this case: How do we define appropriate and inappropriate drug use;
- the distribution of the problem – who is affected, when, and where; and
- the size and intensity of the problem – is it widespread, how severe is it, what are its consequences (such as disability, death, and waste of resources).

### *Step 4 Analyze the problem*

After identifying the core problem one should:

- identify factors that may have contributed to the problem;
- clarify the relationship between the problem and contributing factors.

It is helpful to visualize these interrelationships in the form of a diagram. The basic principles of constructing such a diagram are illustrated below.

Perceived problems and factors contributing to these problems may be placed in boxes. The relationships between them can be indicated by arrows that can be either one-way arrows (for cause-effect relationships) or two-way arrows (for mutual relationships). The core problem can be identified by drawing a double line around it.

*Step 4.1* Write down the main problem(s) as defined in Step 3 in the centre of a black-board or flip chart.

*Step 4.2* Brainstorm on possible causes or factors contributing to the problem.

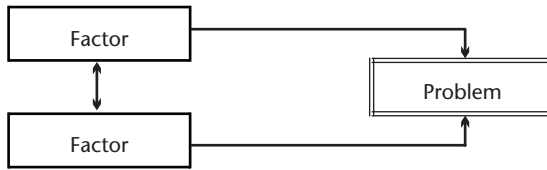
**Figure 22.1** Elements of a Problem Analysis Diagram

It is important that the viewpoints of managers, health care workers, community members or researchers brought up during Step 2 are all included. Discuss the relationships between the different factors and the problem.

If desired, participants may use separate cards or pieces of paper on which to write possible contributing factors. The cards may be pinned or taped around the core problem on the board or flip chart and moved, revised, or eliminated as necessary, during development of the diagram.

Cards for a problem diagram of the rational use of drugs might look like this:

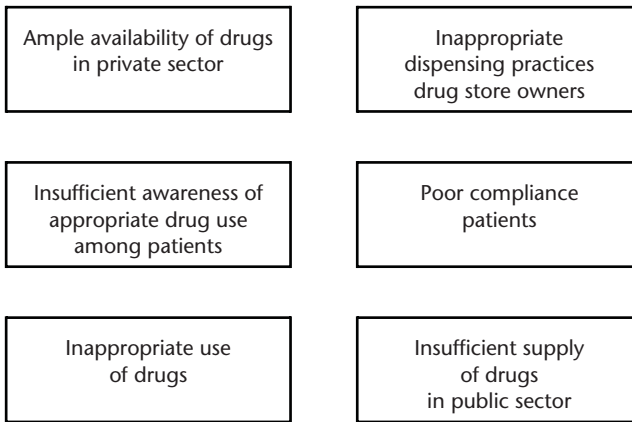
**Figure 22.2** Initial Cards for Problem Diagram – Inappropriate Drug Use

Note that many of the ‘perceived problems’ are related to each other, in a cause-effect relationship (e.g. ample availability of drugs in the private sector contributing to inappropriate drug use by consumers) or in a mutual relationship (e.g. inappropriate prescription practices in the private sector contributing to insufficient awareness about appropriate drug use among consumers, while, at the same time, such insufficient awareness makes it impossible for the patients to comment on prescribing behaviour).

As one can see, this initial diagram suggests that further development of the analysis could proceed in three directions, i.e. analysis of factors related to:

- availability of drugs in both public and private sectors;
- quality of the prescription practices;
- the drug use behaviour and views about appropriate drug use in the community.

These sets of factors will appear in many studies on community drug use. In reality they usually prove to be closely intertwined. Patients' drug use behaviour depends not only on their own educational and cultural background, for example, but also on the quality of the prescription practices and on the availability of drugs in the government health services and in the private sector.

*Step 4.3* Identify further contributing factors.

Extend the problem analysis diagram further by identifying additional factors that could have contributed to or aggravated the problem. It may be possible to identify several 'generations' of predisposing factors.

It is desirable to continue identifying underlying contributing factors until one reaches basic factors that need to be modified in order to solve the problem, and that can be modified within the existing context. This will facilitate the formulation of research projects that can provide useful information for decision-making. This process of continued analysis will necessitate several revisions or extensions of the initial analysis diagram. The final version should encompass all the critical factors that may be contributing to the problem to be studied.

*Step 4.4* Attempt to organize related factors together into larger categories, and develop your final draft of the diagram.

This final step in organizing the diagram will help one not to overlook important factors and will make it easier to develop the data collection tools in a systematic way.

*For example, the revised diagram (see Figure 22.3) focusing on the 'inappropriate use of drugs by consumers' may group contributing factors into four main categories:*

- *socio-cultural factors (for instance, literacy, age, ethnic background, ideas about disease causation);*
- *provision-related factors (for instance, availability of drugs in private and public sectors, prescription practices, availability of traditional medicine);*
- *disease-related factors (for instance, seriousness of the disease, symptoms, complications, lack of progress);*
- *drug-related factors (for instance, whether it is an injection, the reaction to the colour of a capsule, local ideas about efficacy).*

Note that the inappropriate use of drugs by consumers has emerged as the core problem because during the analysis the problem of poor compliance with prescribed therapy was considered too unfocused. We may circle the core problem twice to distinguish it from the boxes that indicate contributing factors.

Further note that this final draft of the diagram is only final in this stage of the study. When the study progresses and more becomes known about the problem, it will be necessary to make new drafts of the problem diagram.



problem is. One would risk concentrating on marginal factors and coming up with marginal solutions. An *exploratory study* (see Module 24) among different target groups (patients, their relatives, health staff, policy-makers) would then be indicated. In that case, one limits the study in the number of informants per target group rather than in the number of factors, so that open research techniques can be applied. These techniques provide an opportunity for identifying even additional factors and patterns of factors which one had overlooked when designing the study.

However, if one is already quite knowledgeable on the problem, because the researcher or others have studied it recently, it might be possible to concentrate on factors which are relatively less known. Usually, successive studies follow a logical sequence. An exploratory study may be followed by a larger survey to further quantify the problem and/or factors which appear to contribute to it, as well as by in-depth studies of limited scope on one or two major contributing factors.

As we continue with sessions on study type, data collection techniques and sampling during the present course, it will be possible to make final decisions on what to include in your study, and how this is to be done. At this point of time it is important to identify and list all sources of information, published and unpublished, which relate to your analysis diagram. Only then can you write an up-to-date statement of the problem and focus your own research.

### 3 Formulating the Problem Statement

The first major section in a research proposal is the *statement of the problem*. Why is it important to state and define the problem well? It is crucial because a clear statement of the problem:

- is the foundation for the further development of the research proposal (research objectives, methodology, work plan, budget, etc.);
- makes it easier to find information and reports of similar studies from which one's own study design can benefit;
- enables one to point out systematically why the proposed research on the problem should be undertaken and what one hopes to achieve with the study results. This is important to highlight when one presents the project to community members, health staff, the relevant ministry, and donor agencies who need to support the study or give their consent.

#### *What Information Should be Included in the Statement of the Problem?*

- 1 A brief description of socio-economic and cultural characteristics and an overview of health status and the health care system in the country or district in as far as these factors are relevant to the problem. Include a few illustrative statistics, if available, to help describe the context in which the problem occurs.
- 2 A concise description of the nature of the problem (the discrepancy between 'what is' and 'what should be') and of its size, distribution, and severity (who is affected, where, since when, and what are the consequences for those affected and for the services?)

- 3 An analysis of the major factors that may influence the problem and a convincing argument that available knowledge is insufficient to solve it.
- 4 A brief description of any solutions tried in the past, how well they worked, and why further research is needed.
- 5 A description of the type of information expected to result from the project and how this information will be used to help solve the problem.
- 6 An overview of available, relevant literature, either as a separate section or integrated in sections 1 to 5, or more commonly, both (see Module 23).
- 7 If necessary, a short list of definitions of crucial concepts used in the statement of the problem.
- 8 A list of abbreviations may be annexed to the proposal, but each abbreviation also has to be written out in full when introduced in the text for the first time.

#### 4 Formulating Objectives and Research Questions

The objectives of a research project summarize what the study should achieve. Objectives should be closely related to the statement of the problem. For example, if the problem identified is low utilization of government dispensaries by women in a rural area, the *general objective* could be to identify the reasons for this low utilization in order to find solutions.

It is necessary to break down a general objective into smaller, logically connected parts, which spell out in detail what information will be collected to gain insight into the reasons for the problem. These are often referred to as *specific objectives*. Specific objectives can also be formulated as *research questions* which generate the required information.

*The study on low utilization of government dispensaries could, for example, generate the following research questions:*

- *What is the level of utilization by women of government dispensaries in sub-district X, during the years 1991 and 1992, as compared with the expectations or targets set?*
- *Are there variations in women's utilization of the dispensaries related to the season, the ailments of the female patients, and the background of female patients served (age, socio-economic status)?*
- *Are there specific factors related to the dispensaries that make them either attractive or unattractive to female villagers, for example:*
  - *distance between home and dispensary;*
  - *availability/quality and costs of the services offered (perspective of services vis-à-vis perspective of clients);*
  - *behaviour of the staff;*
  - *sex of the staff.*
- *Would socio-economic factors influence the women's utilization of a government dispensary, such as:*
  - *socio-economic status/income;*

- *support from husband/other relatives;*
- *women's workload.*
  
- *Would cultural factors influence the women's utilization of dispensaries, for example:*
  - *education and religion;*
  - *perceptions about diseases and preferable ways to cure them;*
  - *self-medication practices.*
  
- *Which other sources of health care are available to village women and how do these compare to the dispensaries? It would be necessary to know, for example:*
  - *distance and costs of other sources;*
  - *specialization of other sources in terms of specific female ailments;*
  - *behaviour of other practitioners toward their female clients.*

The first research question focuses on quantifying the problem. This is necessary in many studies. Often use can be made of available statistics or of the health information system. The second research question further specifies the problem examining its distribution. The remaining research questions consider possible factors that may influence the problem.

Note that the problem analysis diagram is an essential tool in the development of research questions. While elaborating these questions the diagram is usually elaborated still further, simplified or better structured.

In short, the formulation of research questions will help one:

- *to focus* the study (narrowing it down to the essentials);
- *to avoid* collection of data that are not strictly necessary for understanding and solving the problem the researcher has identified; and
- *to organize* the study in clearly defined parts or phases.

Properly formulated research questions will facilitate the development of the research and will help to orient the collection, analysis, interpretation and utilization of data.



---

## Assignment

- 1 Make a problem analysis diagram of the most important components of the problem you have decided to study, or the most important factors that you think are influencing it. Use a blackboard or a flip chart and, if possible, separate cards for each factor. (See part 1 of this Module for details on the steps in this process.) After making your initial diagram try to re-arrange the factors identified into broader categories.
  - 2 Decide whether you can include all factors of your problem analysis diagram in the statement of the problem. In case of doubt, consider two possibilities:
    - a All factors seem important and interrelated; you cannot easily split the diagram up into possible sub-studies as no previous studies have been conducted on this topic in your area? Just continue and we will come back to possible ways of increasing the feasibility of the study when discussing the Modules on Study Types, Data Collection Techniques and Sampling.
    - b The diagram is so complex that several studies would be necessary to cover it while some research has already been done. If so, demarcate the boundaries of possible projects and use the criteria and ranking system in the first exercise on prioritizing problems to select one of the sub-problems as the focus for your project.
  - 3 Prepare a first draft of 2-3 pages of the statement of the problem for the topic you have selected.
    - First, prepare an outline covering items 2 through 5 in the list presented just before this group work session using available information.
    - Then, prepare one or two paragraphs of ‘background information’ that places the problem in its context and will be used as the introduction to the statement of the problem, using available sources.
    - Finally, define crucial terms and explain abbreviations, if necessary.
  - 4 Justification of research on the identified problem is needed.
  - 5 Identify further information you need, from the literature or from key informants, to help you focus your study and to further develop your statement of the problem. Ask course facilitators to give you assistance, if necessary.
  - 6 Develop research questions, making use of the diagram and covering all major factors in a systematic manner.
  - 7 Keep all materials presented in the plenary session, as well as your notes on the comments you received, for use during further development of your proposal.
-



**MODULE 23**

**LITERATURE REVIEW**

# LITERATURE REVIEW

## Objectives

At the end of this Module, the participants should be able to:

- select relevant written sources to be included in the literature review;
- write a critical literature review;
- make a complete and correct reference list.

## Contents

- 1 Introduction
- 2 Different Forms of Literature Review
- 3 Various Written Sources
- 4 Steps in Writing a Critical Literature Review
- 5 Guidelines for Making a Reference List

\* Adapted from Module 5, Health System Research Training Series, Volume 2

## 1 Introduction

A review of written sources can be carried out in the preparatory phase, when a study proposal is elaborated, and/or during the data collection phase, when the fieldwork has already started.

In the preparatory phase, the literature review may start rather broadly – especially when the researcher is not very knowledgeable about the topic or is still formulating the research objectives – in order to give the researcher good insight into the research topic and related issues, theoretical concepts and frameworks. The literature review aims at formulating the right research questions and is often not restricted to the research area, geographically speaking. In the preparatory phase the emphasis is on published articles and books that can be found through computer and library searches, and – if available – published or unpublished study reports.

During the data collection phase, the use of written sources should be much more focused than in the preparatory phase and aimed at finding answers to the research questions. In this phase, the written sources are research-area specific, and often can be found only in the research area, such as articles in local newspapers, hospital statistics, health education and training materials, or brochures from patient organizations.

The focus in this Module is on conducting a literature review in the preparatory phase, but most of what is mentioned here applies to the data collection phase as well.

## 2 Different Forms of Literature Review\*

We can differentiate six types of literature review. These are: *self-study review*, *contextual review*, *integrating review*, *theoretical review*, *methodological review*, *historical review*. A literature review in the preparatory phase may serve several purposes.

By doing *self-study review* the researcher will increase his/hers knowledge about the topic. She or he becomes informed about what others have written about the topic. This stimulates the researcher's own creative thinking. It also helps the researcher to reflect on her or his own bias regarding the research topic. Moreover, by presenting the results of the literature review in the study proposal, the researcher shows her or his familiarity with the topic which increases her or his credibility in the reader's eyes (the proposal reviewer or lecturer).

In the preparatory phase information is collected which enables the researcher to link the study proposal with prior studies, placing it in an overall picture and context, indicating gaps in knowledge, and as such underlining the need for the currently proposed study (*contextual review*). This kind of information generally includes some statistical data which is used in the 'Background' or 'Statement of the Problem' section of a research proposal, indicating why a research project is significant and relevant (see Module 22).

\* This section is adapted from Thongtai and Attig (1993: 85) who discuss six forms of literature review.

The current state of knowledge should be presented in each study proposal by summarizing past research on comparable and related topics in a systematic and logical way. Differences and similarities in research findings should be highlighted and factors that explain them should be discussed. If possible, overall conclusions should be drawn from different studies that address related or comparable topics (*integrating review*).

Different theories and conceptual frameworks that are used to describe and explain the research topic are usually presented, discussed and assessed (*theoretical review*). If the researcher selects a certain theory or conceptual framework as the starting point for her or his own research, the researcher gives the reader insight into the arguments for that choice.

A literature review can also include a short description and evaluation of the methodological strengths and weaknesses of different research projects on similar or comparable topics (*methodological review*). Based on these insights choices made in the methodological section of the proposal can be justified.

Finally, it might be useful to give a *historical review* describing the development of an issue over time, indicating, for example, how and why the research topic and its societal significance have changed; the various ways it has been studied; or changes in theories about it.

Often, the six types of literature review are combined on behalf of one research proposal but occasionally they may be undertaken separately. The researcher has to select what information to include in the review, and in how much detail. Choices depend on various factors: for example on what is already known and written about the research topic; what the researcher already knows about it; and on the research proposal's audience (a donor, a lecturer) and its specific requirements.

### 3 Various Written Sources

A literature review can be based on data from different sources:

- published information: books, articles from scientific journals, national or international newspapers, abstract journals;
- unpublished information: other research proposals, unpublished reports, statistical records, patient files, brochures, newsletters, training or health education materials, annual reports and other written materials produced by non-governmental organisations (NGOs), action groups, or hospitals;
- data from the Internet (worldwide web); and
- diaries, novels, and life histories.

In general, a mix of these sources will be used.

There are several ways to search for relevant literature.

*The 'Traditional' Way, i.e. visiting libraries and documentation centres and contacting key persons*

- 1 Searching for key words and authors in the catalogues of libraries and documentary centres (Ministries of Health, research institutes, NGOs, newspaper offices);
- 2 Examining the reference lists in key papers and books and identifying relevant references;

- 3 Looking for references in indexes and abstract journals;
- 4 Skimming through recent editions of relevant journals; Important international journals in the area of medical anthropology and applied health research are:
  - *Social Science & Medicine*
  - *Medical Anthropology Quarterly*
  - *Anthropology and Medicine*
  - *Health Policy and Planning*
  - *Human Organization*
  - *Studies in Family Planning*
  - *Culture, Medicine and Psychiatry*
  - *Reproductive Health Matters*
- 5 Identifying key persons who are knowledgeable on the literature of the study topic (including researchers, lecturers, health professionals, health activists, and conference speakers) and asking them for references.
 

The advantage of the traditional way is that one has immediate access to the articles and books.

#### *Using the Worldwide Web: Internet Searches*

- 1 This method allows one to log-in and view catalogues from many libraries and documentation centres around the world (and subsequently search for key words and authors). Sometimes one has access to the full text of articles; often libraries offer a copying service. Frequently, these services are free of charge for individuals and institutions in developing countries.

---

#### **Internet sites which provide access to libraries in the field of health and health care in developing countries are listed below.**

- HAIN: [www.kalusugan.org](http://www.kalusugan.org) (resources on sexual and reproductive health)
  - Healthlink Worldwide (former AHRTAG): [www.healthlink.org.uk](http://www.healthlink.org.uk)
  - International Planned Parenthood Federation: [www.ippf.org](http://www.ippf.org)
  - Liverpool School of Tropical Medicine:  
[www.liv.ac.uk/Library/libhomep.html](http://www.liv.ac.uk/Library/libhomep.html)
  - London School of Hygiene and Tropical Medicine: [www.lshtm.ac.uk](http://www.lshtm.ac.uk)
  - Pan American Health Organization: [www.paho.org](http://www.paho.org)
  - ReproLine / Reproductive Health On Line: [www.reproline.jhu.edu](http://www.reproline.jhu.edu)
  - Royal Tropical Institute, Amsterdam: [www.kit.nl](http://www.kit.nl)
  - UNAIDS: [www.unaids.org/publications/documents/index.html](http://www.unaids.org/publications/documents/index.html)
  - United Nations Population Information Network (POPIN):  
[www.undp.org/popin](http://www.undp.org/popin)
  - University of Amsterdam: [www.uba.uva.nl/en/aboutuba/](http://www.uba.uva.nl/en/aboutuba/)
  - WHO: [www.who.int/hlt/index.html](http://www.who.int/hlt/index.html)
  - World Bank (HNP): [www.worldbank.org/html/extdr/hnp/hnp.htm](http://www.worldbank.org/html/extdr/hnp/hnp.htm)
-

---

**Statistical information can be found on the following websites:**

- CIHI (Center for International Health Information):  
www.cihi.com/hthpub.htm
  - DHS (Demographic and Health Survey) Macro International:  
www.macrint.com/dhs
  - WHOSIS (WHO Statistical Information Service):  
www.who.org/whosis/whosis.htm
- 

- 1 To find more relevant websites, the use of ELDIS (a 'Gateway to Information Sources on Development and the Environment') is very practical. This is an Internet site, hosted by the Institute of Development Studies, Sussex, that offers an easy route to the latest information on development and environmental issues in general, and has a special site for health issues (<http://nti.ids.ac.uk/eldis/health/health.htm>). ELDIS provides a large number of descriptions and links involving a variety of information sources, including worldwide web sites, databases, library catalogues, bibliographies, e-mail discussion lists, research project information, maps and newspaper collections. Where there is no Internet link available, other information on the availability of databases, CD-Roms, etc. is given.
  
- 2 Researchers can do or request a computerized literature search in relevant databases. These databases are accessible through Internet and are available on CD-Roms, and are constantly updated. Important databases are:
  - Medline: [www.medscape.com](http://www.medscape.com)  
A database with abstracts of the worldwide literature on medical issues.
  - Popline: [www.jhuccp.org/popline/index.stm](http://www.jhuccp.org/popline/index.stm)  
A database with abstracts of the worldwide literature on population, family planning, and related health issues.

For a comprehensive list of databases in the field of health one can consult the websites of database providers, such as for example Silverplatter ([www.silverplatter.com](http://www.silverplatter.com)). Knowing how to use bibliographic databases effectively is an essential skill for anyone undertaking research in health. In Eyens' (1998) article on 'Searching bibliographic databases effectively', he illustrates the search process using the example of cost-effectiveness of immunization programmes in Africa.
  
- 3 One can search the Worldwide web for relevant websites hosted by NGOs, international organizations, patient groups, etc., which may not necessarily give access to libraries, but which comprise useful information. Some of these sites can be accessed through the websites listed above.



## 4 Steps in Writing a Critical Literature Review

### *Step 1 Skimming and reading material and making notes*

The researcher should try to focus her or his literature search as much as possible as soon as the research objective has become clear. This prevents her or him from spending a lot of time searching, copying and reading literature that will not be used later.

Once seemingly relevant literature has been found, the researcher must first decide its importance. There is no need to read every article or book in detail. In first instance, articles, books and reports can be skimmed: the title, the abstract or summary, the headings and the conclusions often give a good idea of the written source's relevance for the purpose of the review.

Key articles or books have to be identified and read in detail. What comprises 'key' written sources for a given research topic depends on the latest knowledge on the topic in general, and in the research area, in particular. Articles or books which provide an overview of the state of the art on the research topic in various study areas are, of course, key sources. If other studies on the same or a related topic have been done in the study area or in a neighbouring area (district, country), these certainly should be read carefully as well. One can say: the more rare studies are on the research topic, the larger the geographic area from which studies should be drawn. Articles or books that discuss relevant theoretical or methodological issues – even if not dealing with the research topic per se – can also be considered key sources for the literature review.

A practical way to keep track of relevant findings and valuable insights is to highlight important segments of the text with a colour marker or to write key words in the margin; make short notes or summaries of them, and refer to the source and page where it was found. It is recommended to keep these notes in an organized way (per item), for example as separate computer entries, on individual index cards or on different pages in a notebook.

### *Step 2 Making an outline for the literature review*

First, the researcher organizes her or his notes into groups of related findings and statements according to which aspects of the research topic they touch upon. Based on this ordering of the notes and a growing understanding of the research topic the researcher can make the first outline for the literature review: indicating which topics should be discussed, and in which order. All factors mentioned in the problem analysis diagram (Module 22) should be discussed in the literature review. The grouping of contributing factors may help structure the flow of the literature review, e.g. first presenting and discussing the socio-cultural factors, followed by provision-related factors, disease-related factors and background factors. Newly-found factors, mentioned in the literature, may also inform the problem analysis diagram.

When making the outline, the researcher takes care not to be guided by the availability of data alone. If written information on certain aspects is still lacking (while the researcher suspects they play a role because they were, for example, mentioned in the brainstorm session by health workers or the target group) special efforts are made to find literature about these topics. If *all* possible efforts are undertaken to find written information on the research topic in the specific area where the study will take place, and no information can be found, the researcher should include information found on

the same topic in other areas, and to discuss to what extent and why things are expected to be different or similar in the intended research area.

### Step 3 Writing a literature review

Finally, the researcher writes a coherent discussion in her or his own words using all relevant references. This implies not only reporting on their content, but also analyzing and criticizing them and drawing conclusions.

In doing this, the researcher should be aware of various types of possible *bias in the literature*. Therefore, the researcher has to be critical of the existing literature. If doubts exist about certain references, or conflicting opinions or data are found in the literature, these should be discussed openly and critically. In principle, the researcher should avoid including references to publications without checking the original as much as possible.

Biases in a *literature review* can occur if the researcher only presents references which support the author's point-of-view or when far-reaching conclusions are drawn from preliminary research results, or when sweeping generalizations are made based on just one case or a small study.

## 5 Guidelines for Making a Reference List

When using written sources, published or unpublished, the researcher should make sure that she or he can give a correct and complete list of the sources referred to in the study proposal, the study report or thesis. Guidelines on the exact order and layout for references vary among journals, books and training institutes.

A frequently used reference style is the Harvard style:

- In the main body of the text, list the author's name (no initials), comma and date, e.g. (Helman, 2000). If there are three or more authors, one should use the term et al., e.g. (Hardon et al., 2000).
- References should be listed alphabetically by author at the end of the proposal or report in a double-spaced format.
- To refer to an *article* the following form is used: the author's name, initials, year of publication, article title, full journal title, volume and page range, e.g.:

Inhorn, M. 1994, Kabsa (A.K.A. Musharara) and Threatened Fertility in Egypt, *Social Science & Medicine* 39, 487-505.

- References to a *book* should include the author's name, initials, year of publication, title, edition, publisher and place of publication, e.g.:

Tan, M.L. 1999, *Good Medicine. Pharmaceuticals and the Construction of Power and Knowledge in the Philippines*, Het Spinhuis, Amsterdam.

- References to a *chapter in a book* should include the chapter author's name, initials, year of publication, chapter title. In: name of editor(s) of book, title of book, publisher and place of publication, e.g.:

Reis, R. 2000, The 'Wounded Healer' as Ideology. The Work of Ngoma in Swaziland, in: Rijk van Dijk et al. (eds), *The Quest for Fruiton through Ngoma. The Political Aspects of Healing in Southern Africa*, James Currey Publishers, Oxford, pp. 61-75.

- The reference for a *document / article from the world wide web* should follow the format:

Author(s) (surname followed by initials), title of the document / article, page number on the site. Website address (www:\... etc.) Date that the document entered the site or the date it was last updated.

All relevant details should be written on cards or placed in a separate file on the computer. Doing this immediately from the beginning of the literature search is time-saving – even when one is not yet sure if all the sources will ultimately be included in the reference list.

Researchers intending to publish their research findings in a scientific journal might profit from the guidelines created to assist potential authors in successfully submitting articles for publication as presented in an editorial article in *Social Science & Medicine* by Gordon (2000).

## References

- Eyens, J.E.  
1998 'Searching bibliographic databases effectively.' *Health Policy and Planning* 13 (3): 339-342.
- Gordon, A.J.  
2000 'Guidelines for contributors to Social Science and Medicine.' *Social Science & Medicine* 50 (1): 3-15.
- Thongthai, V. & G.A. Attig  
1993 'The Literature Review and Documentary Research.' In: B. Yoddummern-Attig et al. (eds), *Qualitative Methods for Population and Health Research*. The Institute for Population and Social Research, Mahidol University, Thailand, pp. 82-90.

## Exercises

- 1 Imagine you are preparing a study proposal on social, cultural and economic aspects of immunization in your country. Do a literature review for that proposal. Carry out a literature search and hand in a list of the ten most relevant articles, books and other documents you found and make correct references. List in what way you found these references (list of relevant key words or authors; library catalogues accessed; websites visited, etc.). This exercise can be done with a fellow student.
  
  - 2 Carry out a literature search for your own research proposal. List the references in the correct way, skim the articles that you can access; select which are key articles and which are 'probably relevant' references, and indicate briefly the relevance of each reference for your literature review. Based on this, you can make an outline of your literature review and discuss it with your supervisor.
-

**STUDY TYPES AND DESIGNS**

# STUDY TYPES AND DESIGNS

## Objectives

At end of this Module, the participants should be able to:

- describe the study types most often found in AHR and the advantages and limitations of each study type;
- describe various study designs and be able to choose between them;
- identify the most appropriate study type and design for the research proposal you are developing.

## Contents

- 1 Introduction
- 2 Overview of Study Types
- 3 Overview of Options for Study Designs

\* Adapted from Module 9, Health Systems Research Training Series, Volume 2

## 1 Introduction

Depending on the existing state of knowledge about a problem that is being studied, different types of questions may be asked that require different study types. Some examples are given in Table 5.1.

**Table 24.1** Research Questions and Study Types

<i>State of knowledge of the problem</i>	<i>Type of research questions</i>	<i>Study types</i>
- Knowing that a problem exists, but knowing little about its characteristics or possible causes	- Who is affected - How do the affected people behave? - What do they know, believe, think about the problem? - What is the nature/magnitude of the problem?	- Exploratory studies or - Descriptive studies
- Suspecting that certain factors contribute to the problem	- Are certain factors indeed associated with the problem? What is the main cause of the problem?	- Comparative (= analytical) studies
- Having sufficient knowledge about the cause to develop and assess an intervention that would prevent, control, or solve the problem	- What is the effect of a particular intervention? (e.g. being exposed to a certain type of health education message) - Which of two alternative strategies gives better results? Are the results in proportion to time/money spent?	- Intervention (= action) studies

The study types chosen depend on:

- The type of problem;
- The knowledge already available about the problem; and
- The resources available for the study.

## 2 Overview of Study Types

Several classifications of study types are possible, depending on what research strategies are used. Here we discuss the following study types which are most common:

- Exploratory studies;
- Descriptive studies;
- Comparative studies; and
- Intervention studies.

Often, a combination of these study types is used within one research.

## A *Exploratory Studies*

---

An EXPLORATORY STUDY is a small-scale study of relatively short duration which is carried out when little is known about a situation or a problem.

---

Applied Health Research usually begins with an exploratory research phase in which the researcher attempts to gain insight into a problem by investigating people's views on the problem, how people interpret the nature of the problem, and how they seek solutions. He or she will learn about the concepts that respondents use in describing the problem and about the causes of the problem that they identify. The researcher will need to speak the local language or work with a translator.

In preparing the exploratory study, the most important element of the field work is *being there*: to observe, to ask seemingly stupid yet often informative questions, and to write down what is heard and seen. The researcher doing fieldwork will have to develop a number of general questions and more specific topics for discussion. These topics can be addressed by use of in-depth interviews with key respondents of the community, in participant observation or in group discussions.

*When studying why men and women do not use contraceptives, an anthropologist will ask people questions about their reproductive histories, reproductive physiology, and about their views of the contraceptive technologies that are available in the health centres. The researcher may ask respondents to draw the reproductive organs of a woman and a man and may request them to explain how, in their view, the contraceptive methods work. In discussing these topics the researcher can learn the concepts that people use to describe the effects of the methods; they may start to understand why people do not use the contraceptive methods that are available in the local health care centres.*

When doing a descriptive study we describe the views and needs of people and the possibilities for action. We may want to go further and try to *explain* the differences we observe (e.g. why some women deliver at home and others in the hospital) to identify causes of problems. Then we will need to compare groups. Small-scale studies that *compare* extreme groups are very useful for exploring and describing problems. We could, for example, compare forty mothers who delivered in a maternity ward and forty who delivered at home to find reasons for the low percentage of supervised deliveries.

Descriptive studies gain in value if we approach the problem from different angles at the same time. In the study that is looking for causes of low utilization of family planning services, it may be very useful to include interviews with health staff in the family planning centres and interviews with their supervisors, as well as informal discussions with users. In this manner, information from different independent sources can be cross-checked.

After the initial phase of an exploratory study the researcher will review his or her list of questions and topics, and will develop a new list that is relevant to respondents' every-



day lives to further study the problem at hand. After such exploratory work has been done (s)he can develop a diagram in which the most important factors contributing to the problem are presented. This can be used as a basis for a next, more analytical, phase of the research. If the problem and its contributing factors are not well defined it is always advisable to do an exploratory study before embarking on a large-scale descriptive or comparative study.

## B Descriptive Studies

---

A Descriptive STUDY involves the systematic collection and presentation of data to give a clear picture of a particular situation.

---

Descriptive studies can be carried out on a small or large scale. *Case studies* describe the characteristics of one or a limited number of cases extensively. The subject of a case study may be a patient, a health centre, or a village. Such a study can provide useful insight into a problem. Case studies are common in social sciences, management sciences and clinical medicine. For example, in clinical medicine the characteristics of a hitherto unrecognized illness may be documented as a case study. This is often the first step toward building up a clinical picture of that illness. Extended case studies are also frequently used in anthropological studies. A 'thick' description of an illness case and the subsequent health seeking behaviour not only produces information on behaviour and practices, but also on underlying ideas and beliefs.

However, if one wishes to test whether the findings pertain to a larger population a more extensive survey has to be designed. *Surveys* aim at quantifying the distribution of certain variables in a study population at one point in time. Surveys have long been an important part of anthropological research. Surveys can be viewed as a focused, organized means of data collection. Crane and Angrosino (1992) note that the survey is a logical and necessary complement to participant observation and related techniques that are based on subjective immersion in a cultural setting. They may cover, for example:

- Physical characteristics of people, materials, or the environment, as in:
  - prevalence surveys (measuring the prevalence of bilharzia, leprosy),
  - evaluation of coverage (of immunization, latrines, etc.);
- Socio-economic characteristics of people, such as their age, gender, education, marital status, number of children, and income;
- The behaviour of people and the knowledge, attitudes and beliefs of people that may help to explain that behaviour (*KAPB studies*); or
- Events that occurred in the population.

Usually surveys cover a sample of the population (for example, a household survey). Surveys can reveal interesting associations between certain variables, e.g. between having leprosy and socio-economic status, sex, and education. Researchers who conduct a survey often go further and will combine a description of the study population with a comparison of a number of groups within that population. Such combinations are very common.

For some problems such a ‘rapid appraisal’ may provide sufficient information to take action. Otherwise a larger, more rigorous comparative study will have to be developed to test differences between groups.

### C *Comparative Studies*

---

A COMPARATIVE STUDY attempts to explain/understand problems by establishing causes or associated factors for certain problems. This is done by comparing two or more groups some of which have or develop the problem and some of which have not.

---

Comparison is a fundamental research strategy to identify factors that help *explain* why one group of persons or objects differs from another. A study involving a comparison between groups provides a stronger basis for analysis than a research only involving one group.

Many surveys focus on comparing as well as describing groups.

*A survey on malnutrition may wish to establish:*

- *the percentage of malnourished children in a certain population;*
- *feeding practices;*
- *knowledge and certain beliefs that influence these practices;*
- *socio-economic, physical, and political variables that influence the availability of food.*

*The researcher will not only want to describe these variables but, by comparing malnourished and well-nourished children, he or she will try to determine which socio-economic, behavioural, and other independent variables have contributed to malnutrition.*

In doing a comparative study a researcher may choose from various study designs most appropriate for the research questions. Three examples will be discussed here:

- A study comparing cross-sections of a population or geographical settings;
- A case-control study;
- A cohort study.

#### *Case-Control Study*

Case-control studies are widely used in epidemiological studies. In studying the case and the control groups, the researcher can try to identify factors that are associated with the problem, called risk factors in epidemiological research. For example, in the case of malnutrition, bottlefeeding could be an important associated risk factor, occurring more in the malnourished group than in the well-nourished group. Another associated factor could be lack of income.

A CASE-CONTROL STUDY is a particular type of comparative study. In a case-control study, the investigator compares one study group among whom a problem is present with another group, called a *control or comparison group* where the problem is absent. This comparison helps the researcher to discover what factors have contributed to the problem.

In case-control studies, one starts with the outcome (malnourished and well-nourished children) and then looks back to determine the presence or absence of certain associated factors. This we call a retrospective study design.

Past ←————— Present  
(Retrospective study, looking back: case-control studies)

The advantage of case-control studies is that they are relatively quick and inexpensive to undertake. The major problem with case-control studies is the selection of appropriate control groups.

**Figure 24.1** Diagram of a Case-Control Study

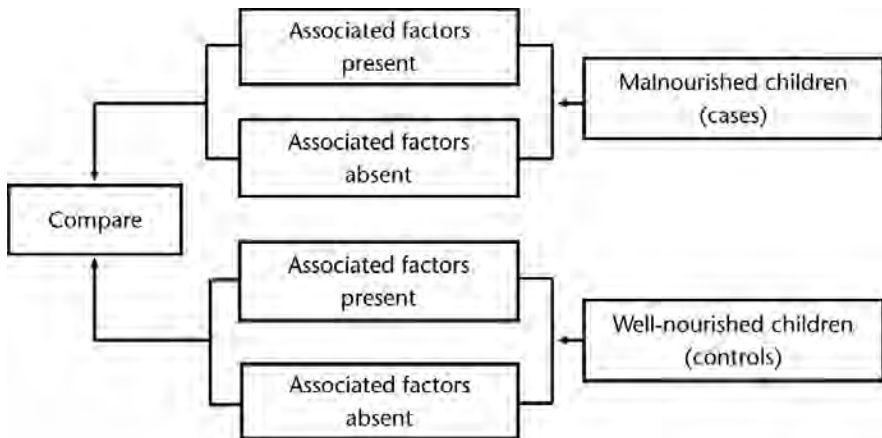

### *Cross-Sectional or Geographical Comparison Study*

A comparative study can also compare groups or cross-sections of a population as they are in the present. In the case of the malnutrition example such a study would compare families with malnourished children with those with well-nourished children. This could be carried out within one community. Comparative studies may also cover geographical areas or settings comparing one community with high malnutrition rates with another with low malnutrition rates. In this case the researcher could try to discover which factors are present in the first community that could explain this discrepancy.

ancy. Examples of these factors could be differences in ethnic background, income levels, or differences in hygienic conditions.

Two advantages of geographical or cross-sectional comparisons are that they are relatively easy to carry out and that differences between settings and groups can be investigated. Some problems with this method are that it cannot always be determined whether these differences are responsible for variations found in malnutrition rates and that the outcome of risk factors cannot be measured over time.

### *Cohort Study*

Comparative studies can also take a different approach. By following groups of people among whom a certain risk factor is *prospectively* present (looking from the present into the future), one could discover to what extent certain health problems occur in these groups. Such studies are called prospective studies, in contrast to the retrospective design used in case-control studies.

Present —————> Future  
(Prospective study, looking into the future: cohort studies)

In epidemiological research prospective comparative designs are called *cohort studies*. The aim of cohort studies is to determine the role of a certain associated factor in the development of a condition or disease. This associated factor can be a certain behaviour (such as smoking) or an etiological agent (such as exposure to radiation or to famine).

---

In a Cohort Study a group of individuals that is exposed to a risk factor (= study group) is compared with a group of individuals not exposed to the risk factor (control group). The researcher follows both groups over time and compares the occurrence of the problem that (s)he expects to be related to the risk factor in the two groups, to determine whether a greater proportion of those with the risk factor are indeed affected.

---

From a sample drawn from the population it is determined which individuals have the particular associated factor (who are *exposed*) and which individuals are not. The researcher will then follow both groups over a number of years to determine whether there is an association between exposure and disease. Cohort studies in the past have helped researchers to determine, for example, the association between smoking and lung cancer and heart disease. To determine the importance of an associated risk factor, cohort studies usually require a large sample. Since the same groups of people have to be followed over a number of years to determine the outcome (disease or not), a prospective study design is not only labour intensive and thus very expensive, but also difficult to conduct.

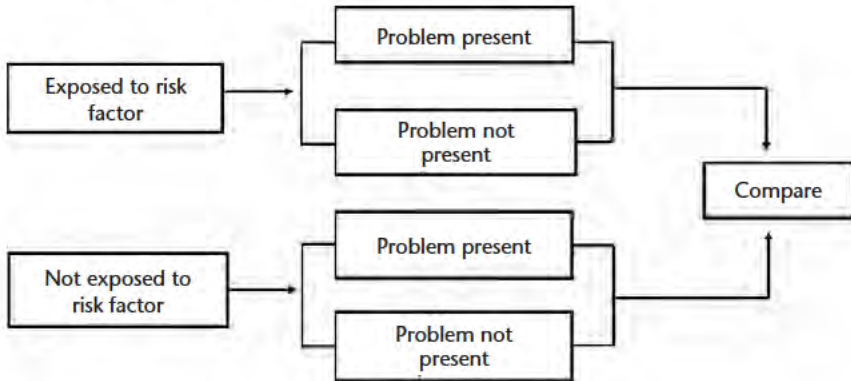
**Figure 24.2** Diagram of a Cohort Study

A study trying to establish the relationship between bottlefeeding (= risk factor) and malnutrition (= problem) could be designed as a cohort study. A group of infants delivered in a maternity clinic, all from low income families, could be followed twice monthly over a twelve month period through personal home visits by trained field workers. A distinction could be made between those who were breastfed and those who received bottlefeeding only, and a third group who received mixed feeding. During the study, the incidence of diarrhoeal diseases and other conditions could be compared, as well as growth charts and infant mortality rates across the three groups.

Such a prospective study design which involves close contact with informants, combined with qualitative research methods such as in-depth interviews, could also shed some light on the way mothers from low income families deal with the illness episodes of their children. Health seeking behaviour of the three groups could be compared. The study mentioned above could offer explanations for the under-utilization of health services in severe cases of acute diarrhoeal diseases in children. It could also explain the rationale behind mothers' feeding decisions: why bottle-feeding is often preferred despite its higher cost.

- \* There are two different ways to measure the occurrence of disease in a population: *incidence* and *prevalence* rates.

Incidence rate per 1,000: Number of *new* cases of a disease occurring in the population during a specified period of time / number of persons exposed to risk of developing the disease during that period of time x 1,000.

Prevalence rate per 1,000: Number of *all* cases of disease present in the population during a specified period of time / number of persons in the population at that specified time x 1,000.

The difference between these rates is especially apparent in chronic ailments with a long duration. The prevalence rate equals the incidence rate times the average duration of the disease.

The major advantage of cohort studies is that they are the only certain way to establish causal relationships. However, they take longer than case-control studies and since they are labour-intensive, they are expensive. Another major problem is the inability of the researcher to follow-up all persons included in the study over the course of a number of years.

To summarize the differences between the various comparative studies we will present another example.

*If you assume there is a causal relationship between the use of a particular water source and the incidence of diarrhoea among children under five in a village using different water sources:*

- You can select a group of children under five and check at regular intervals (e.g. every two weeks) whether the children have had diarrhoea and how serious it was. Children using the suspected source and those using other sources will be compared with regard to the incidence of diarrhoea (*cohort study*).
- You can also conduct a **case-control study**. You may compare children who present themselves at a health centre with diarrhoea (cases) during a particular time with other children (controls) presenting themselves with other complaints of roughly the same severity (for example acute respiratory infections) during the same time and determine which source of drinking water they had used.
- In a **cross-sectional comparative study**, you could interview a sample of mothers in the village to determine how often their children have had diarrhoea during, for example, the past month, and obtain information on their source of drinking water. You then compare the source of drinking water of children who were reported as suffering from diarrhoea with those who were not.

#### **D Intervention Studies**

---

In Intervention or ACTION-ORIENTED studies as well as EVALUATIVE studies, the researcher intervenes in a situation and evaluates or measures the effects of this intervention.

---

Here we discuss two approaches commonly used in intervention studies: a study design using two groups (*quasi-experimental study*) and a design in which one study group is compared before and after the intervention (*before-after study*).

### Quasi-Experimental Intervention Study

Intervention studies often use a QUASI-EXPERIMENTAL DESIGN with two (or more) groups, one of which serves as a control group in which no intervention takes place. Both groups are observed prospectively, before as well as after the intervention, to test if the intervention has made any difference.

**Figure 24.3** Diagram of a Quasi-Experimental Design with Two Groups

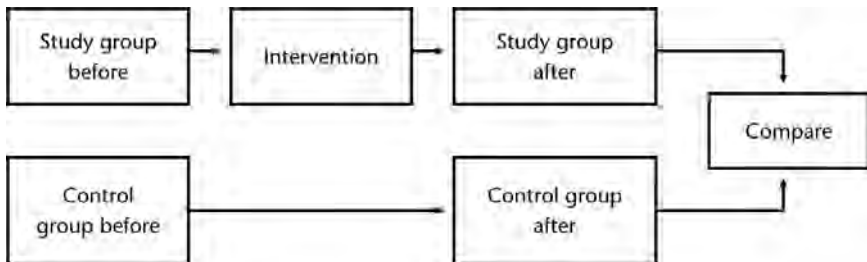

*A researcher plans to study the effects of health education on the level of participation of a village population in an immunization campaign. She decides to select one village in which health education sessions on immunization will be given and another village that will not receive health education to serve as a control. The immunization campaign will be carried out in the same manner in both villages. A survey will then be undertaken to determine if immunization coverage in the village where health education was introduced before the campaign is significantly different from coverage in the control village which did not receive health education.*

### Before-After Study

Another type of design that is often chosen because it is quite easy to set up, uses only one group in which the intervention is carried out. The situation is analyzed before and after the intervention to test if there is any difference in the observed problem. This is called a *before-after study*.

*The outpatient clinic of hospital X is extremely crowded. Waiting times of over 5 hours for patients before they are attended to are not uncommon. The hospital management has carried out a study to analyze the bottlenecks and implements most of the recommendations made. Three months later, another study is done to check to what extent the problem has been solved and where further action is necessary.*

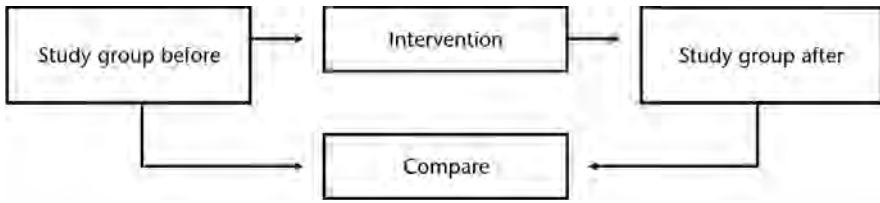

**Figure 24.4** Diagram of a Before-After study

This design is often used for management problems that pertain to one single unit (hospital, school, village). However, if the problems occur at a larger scale or if they might be influenced by other factors apart from the intervention during the trial, it is highly recommended that the design include both a study and a control group.

*In the trial with health education on immunization, for example, it would have been quite risky to work without a control group. Outside events (such as a health education campaign on immunization by radio or other mass media) might have led to improved knowledge on immunization in both the study group and the control group. If you had had just a single study group and no control group, you might have erroneously concluded that the total increase was due to your own intervention.*

### Conclusion

Four major types of studies were classified:

- Exploratory studies;
- Descriptive studies;
- Comparative studies; and
- Intervention studies.

These types of study correspond with different research objectives. However, it is important to stress that these study types are very much interrelated and overlap considerably. Most explorative studies will also attempt to describe a problem. A descriptive study will usually try to analyze the problem. In many anthropological studies exploratory, descriptive, and analytical objectives are so blended that often it does not make sense to label them by any particular types. One may conclude that this classification is based upon 'ideal types of research'. It depends on the research questions whether the main focus of the study is exploratory, descriptive or analytical.

Furthermore, one may also see these different study types as subsequent research phases. Applied Health Research which uses an anthropological approach often starts with an exploratory/descriptive phase before going into higher levels of analysis and hence intervention. This has the advantage that the wider socio-cultural context, including behavioural associated factors, can be better understood.



### 3 Overview of Options for Study Design

In designing a study, a researcher has several options at his/her disposal. These design options depend on the aims of the research. By listing the various options below, we want to show that, within each study type, several approaches are possible.

---

The selection of an appropriate STUDY DESIGN depends on:

- the state of knowledge about the problem;
  - the nature of the problem and its environment;
  - the resources available for the research; and
  - the ingenuity and creativity of the researcher.
- 

A researcher will have to select the options most suited to his/her research objectives, possibilities and budget. The options listed below are merely a selection of the possibilities.

#### *Qualitative or Quantitative Study*

A study can be qualitative or quantitative or a combination of both. The decision whether your study is qualitative or quantitative depends on the research questions. If your research questions involve questions such as ‘how often ...’ or ‘what is the coverage or distribution of the problem’, then quantitative research methods are most appropriate. Quantitative research has the advantage that, if performed correctly, it may generate conclusions that can be generalized. If the research focuses on questions such as ‘why’ and ‘how’ then qualitative methods are more appropriate. Qualitative research may produce more insight and in-depth information.

A *combination* of both options helps us to approach a problem both in-depth, and in general. Quantitative study designs will be discussed in Module 19, while qualitative study designs are dealt with in Module 18.

#### *Comprehensive or Focused Study*

A study may be *comprehensive* in approach, trying to describe the wider socio-economic and cultural context of a problem. This usually requires an in-depth study and a lot of time. An example of comprehensive studies are anthropological *ethnographies*. A comprehensive study of nutrition would include not only a discussion of calory intake and diet, but also of relevant beliefs about nutrition and food taboos, an analysis of food production and distribution, social and family structure.

In a *focused* study, the scope of the researcher is ‘narrowed down’ to the core problem and relevant contextual information. An example of a focused study could be the *Rapid Appraisal Procedure* (RAP). In a nutritional RAP conducted in Pahou (Benin) both the areas of research and the steps of the procedure were determined precisely leaving room for flexibility of the implementation (Varkevisser et al. 1993).

For some studies the rapid assessment may provide sufficient information to answer the research questions because the researcher already knows the community's culture or has previous knowledge of the problem. If the researcher does not know the culture of the community studied and has little knowledge about the problem, an ethnographic or comprehensive study should be conducted.

### *Micro or Macro Study*

The focus of the study can be on the 'micro' level or on the 'macro' level. For example, in a study into injection practices and preferences one may focus on the household level (micro); in this case one can try to establish the prevalence of injections in the household in the past two weeks; or one can ask household members which treatment they prefer for a certain type of illness, how they view injections etc. A macro study could focus on the national level. This study could gather data on injection use in health centres and hospitals, could interview policy-makers and district officers.

In a *multi-level perspective* study several levels (micro-meso-macro) of a health system are being compared.

Other study designs that were already discussed in this Module are:

### *Retrospective versus Prospective Study*

In a retrospective study the focus is back in time, in a prospective study the focus is forward in time. An example of a retrospective design is a case-control study, while an example of a prospective design is the before-after study.

### *Comparative or Non-Comparative Study*

As discussed above, a comparative design has many advantages especially if generalization of the findings is desired. One may compare several levels of organization (multi-level study), different settings, the same group across time (cohort study), or cases and controls (case-control study). However, comparison is not always possible. Also, bias (distortion) is a serious threat to every comparative design. This will be discussed in Module 16.

An example of a non-comparative design is the detailed case study.

### *Participatory or Non-Participatory Research*

This study design focuses on the decision to involve the community or people under study in the decision-making process of the research project or not. One of the major characteristics of AHR is its participatory nature. Participation of the research subjects in research design is not always feasible or possible. Not all data collection tools allow for active participation. Researchers must strike a balance between involving the research subjects as much as possible on the one hand and the demands of scientific research on the other.

## References

- Babbie, E.R.  
1973 *Survey Research Methods*. Belmont: Wadsworth.
- Campbell, D.T. & J.C. Stanley  
1963 *Experimental and Quasi-Experimental Designs for Research*. Chicago: Rand McNally.
- Crane, J.G. & M.V. Angrosino  
1992 *Field Projects in Anthropology. A Student Handbook*. Illinois: Aaveland Press Inc.
- Holland, W., R. Detels & G. Knox (eds.)  
1984 *Oxford Textbook of Public Health. Volumes 1-4*. Oxford: Oxford University Press.
- Kelsley, J.L., W.D. Thompson & A. Evans  
1986 *Methods in Observational Epidemiology*. New York: Oxford University Press.
- Kleinbaum, D.G., L.L. Kupper & H. Morgestern  
1982 *Epidemiological Research*. Belmont: Lifetime Learning Publications.
- Kidder, L.H. & C.M. Judd  
1987 *Research Methods in Social Relations*. Hong Kong: CBS Publishing Japan Ltd.
- McMahon, B. & T.F. Pugh  
1970 *Epidemiology: Principles and Methods*. Boston: Little, Brown and Company.
- Moser, C.A. & G. Kalton  
1979 *Survey Methods in Social Investigation*. Hants: Gower Publishing Company.
- Schlesselman, J.J.  
1982 *Case-Control Studies*. New York: Oxford University Press.
- Varkevisser, C.M., E. Alihonou & S. Inoussa  
1993 *Rapid Appraisal of Health and Nutrition in a PHC Project in Pahou, Benin. Methods and Results*. Amsterdam: Royal Tropical Institute (KIT), PDS-Pahou Series 2b.
- Yin, R.K.  
1984 *Case Study Research: Design and Methods*. London: Sage Publications.

## Exercise

The group work exercise on the selection of study types is combined with an assignment on the selection of data collection techniques. It comes at the end of Module 17.

---

**MODULE 25**

**RESEARCH THEMES,  
VARIABLES AND VALIDITY**

## RESEARCH THEMES, VARIABLES AND VALIDITY

### Objectives

At end of this Module, the participants should be able to:

- offer a description of research themes are, and how they are operationalized;
- describe what variables are and how they are defined;
- understand the difference between dependent, independent and confounding (intervening) variables;
- understand the importance of the validity and reliability of the research findings;
- employ strategies to deal with threats to validity in research design.

### Contents

- 1 Introduction
- 2 What is a Research Theme?
- 3 What is a Variable?
- 4 Dependent and Independent Variables
- 5 Contextual and Confounding Variables
- 6 The Validity and Reliability of Conclusions

\* Adapted from Module 8, Health Systems Research Training Series, Volume 2

## 1 Introduction

The study type that you choose depends to a large extent on the general state of knowledge on the problem you will research. In Module 22, we analyzed a problem we want to investigate. The problem itself, and all the factors that might influence it, were presented in a diagram which then served as the basis for the formulation of research objectives. Depending on the research objectives we discussed various study types and options for designs in Module 24.

In further developing our study design, it is essential that the problem itself, as well as each of the factors we identified when analyzing the problem in Module 22, be carefully defined. To do this we identify *research themes* and *variables*. Variables are most useful in studies in which researchers want to quantify the results. By defining a variable, the researcher clarifies which factor will be counted and which not. In more exploratory or qualitative studies, the variables to be covered in the study are usually not yet defined. In such cases, we speak of *research themes*.

## 2 Research Themes

Usually, in exploratory studies, the researcher makes a list of *research themes* based on the specific research questions that have been defined and the problem analysis diagram. This list is constantly revised and expanded. For example, in an exploratory study of care for the elderly in a poor Bangladesh community, the researcher listed several factors that he thought might be related to the problem under study (Neeloy, 2000). He made four groups of factors (research themes and variables): those related to the individual elderly, to his/her family, to perceptions on care and the elderly, and to the available policies and services (see matrix).

**Matrix 25.1** Factors related to care for the elderly in a poor Bangladesh community:  
Research themes and variables

<i>Individual factors</i>	<i>Family factors</i>	<i>Perceptions</i>	<i>Policies and Services</i>
Social position	Composition of domestic group	Regarding old age	Government policy for the elderly
Image in community	Number of adult children	Regarding care for the elderly	Access to health care
Owning property	Education of children		Housing for the elderly
Marital status	Family income		Economic support for the elderly
Health status	Relationship with relatives		
Position in family	Religious practices		

Some of these factors are variables, such as ‘number of adult children’ (which can be readily measured), others are themes which must be operationalized before they can be used in the field.

The research theme ‘image in community’, for example, is based on the following: In rural Bangladesh peasants live close to each other. Neighbors and relatives play an important role in the social network. Sharing personal matters among neighbors is very common. This sharing makes a person known to many others in the *somaj* (the group associated with a person’s every day life). The researcher assumed that the way an elderly person interacted within his/her *somaj* during his/her active life influences the image that others have of that person. This image, in turn, might influence whether or not people give or do not give assistance to that person when he/she has grown old.

To get insight on the influence of the research theme ‘image in community’ the researcher has to operationalize this further, not in measurable terms, but in descriptive terms. It might be useful in this phase of the study to use the definition of a research theme (concept) as found in other studies on the themes or in an anthropological handbook.

Research themes are used to focus discussion, interviews, and observations. In this example, data have to be collected on:

- the role and position of the elderly in his/her *somaj* now and in the pastformer days;
- assistance given to the elderly person by people from his/her *somaj*.

In the course of the research, the list of themes is expanded and changed in the light of the preliminary results already obtained. When conducting initial interviews, focus group discussions, or participant observation, researchers have to listen and watch carefully to identify such new themes. For example, in a study on self-medication practices in Manila’s slums, Hardon (1990) found that people evaluate efficacy of medicines using the concept *hiyang*. Medicines are labelled not *hiyang* if they do not make the patient better. In further interviews Hardon found that a medicine is *hiyang* if it is compatible with the patients; it suits him/her. This notion of ‘compatibility’ is an important part of the lay self-care culture: people do not attribute a medicine’s efficacy to its chemical content, but to its *relation* with the medicine user.

In exploratory studies a flexible approach is crucial in order to identify the relevant factors that should be studied in more detail in subsequent research. The results can be used to develop a revised problem analysis diagram that includes relevant factors and their context.

### 3 What is a Variable?

---

A VARIABLE is a characteristic of a person, object, or phenomenon that can take on different values.

The values of variables can be expressed in numbers. These are then called NUMERICAL VARIABLES.

The values of variables can also be expressed in categories. Then these are called CATEGORICAL VARIABLES.

---



A simple example of a numerical variable is a person's age. The variable age can have different values when a person is aged 20 to when that same person is 40 years old.

Other examples of numerical variables often encountered in Applied Health Research are:

- Weight (expressed in kilograms or in pounds);
- Distance between homes and clinic (expressed in kilometres or in minutes walking distance); and
- Monthly income (expressed in dollars, rupees, or baht).

The different values of a variable may also be expressed in *categories*. For example, the variable sex has two values, male and female, which are distinct categories. Other examples are:

**Table 25.1** Examples of Categorical Variables

<i>Variables</i>	<i>Categories</i>
Color	red blue green, etc.
Outcome of disease	recovery chronic illness death
Main type of staple food eaten	maize millet rice cassava, etc.

### *Factors Rephrased as Variables*

When looking at the analysis diagram developed in Module 22, you will notice that most of what we called 'factors' (for convenience sake) are in fact variables which have *negative values*. We decided that inappropriate drug use among consumers' was related to factors such as "insufficient awareness of appropriate drug use of consumers', 'inappropriate prescribing and dispensing practices', and 'insufficient supply of drugs in the public sector'.

As we conduct our study and try to determine to what extent these variables play a role we have to formulate the variables in a *neutral* way so that they can take on positive as well as negative values. The table below presents examples of negative 'factors' and how they can be rephrased as neutral 'variables'.

**Table 25.2** Factors Rephrased as Variables

<i>Factors as presented in the analysis diagram</i>	<i>Variables</i>
Long waiting time	Waiting time
Absence of drugs	Availability of drugs
Lack of supervision	Frequency of supervisory visits
Poor knowledge of the signs, causes, and consequences of TB	Knowledge of the signs, causes, and consequences of TB

### *Operationalizing Variables by Choosing Appropriate Indicators*

Note that the different values of many of the variables presented up to now can easily be determined. However, for some variables it is sometimes not possible to find meaningful categories unless the variables are made operational with one or more precise *indicators*. Operationalizing variables means making them measurable.

*In many AHR studies, you want to determine the level of knowledge concerning a specific issue. This will assist you in determining to what extent the factor 'poor knowledge' influences the problem under study, for example low utilization of ante-natal care by pregnant women.*

*The variable 'level of knowledge' cannot be measured as such. You must develop a series of questions to assess a person's knowledge on, for example ante-natal care and risk factors related to pregnancy. The answers to these questions form an indication of the person's knowledge on this issue that can now be categorized. If 10 questions were asked, you may decide that the knowledge of those with:*

- 0 to 3 correct answers is poor;
- 4 to 6 correct answers is reasonable; and
- 7 to 10 correct answers is good.

When defining variables on the basis of the problem analysis diagram, it is important to realize which variables are measurable as such, and which ones need indicators. Once appropriate indicators have been identified, we know exactly what information we are looking for. This makes the collection of data as well as the analysis more focused and efficient.

### *Defining Variables and Indicators of Variables*

To ensure that everyone (the researcher, the data collectors, and, eventually, the reader of the research report) understands exactly what has been measured, and to ensure that there will be consistency in the measurement, it is necessary to clearly define the variables and indicators of variables.

*To define the indicator 'waiting time' it is necessary to decide what will be considered the starting point of the waiting period, e.g. is it when the patient enters the front door, or when he or she has been registered and obtained a card?*

For certain variables, it may not be possible to define adequately the variable or the indicator immediately because further information may be needed for this purpose. Researchers may need to review the literature to find out what definitions have been used by other researchers, so that they can standardize their definitions and thus be able later to easily compare their findings with those of other studies. In some cases, the opinions of 'experts', or community members or health care providers may be needed to define the variable or indicator.

*In a study of referrals made by health centres to a large hospital, one variable that may be studied is the adequacy of the information that is provided to the hospital by the staff of the health centre. To define the items of information that should be included and the criteria for determining adequacy (e.g. 5 out of 5 items or at least 3 out of 5 items), information is needed from the relevant health care providers.*

In such cases, it is necessary to identify and state the method that will be used to develop the definitions of the variables or indicators.

Note, however, that in some studies the researcher is not primarily interested in measuring variables, but rather in identifying variables or clusters of variables that help explain a problem or reasons for success.

#### 4 Dependent and Independent Variables

Because in applied health research you often look for causal explanations, it is important to make a distinction between dependent and *independent* variables.

---

The variable that is used to describe or measure the problem under study is called the **DEPENDENT** variable.

The variables that are used to describe or measure the factors that are assumed to cause or at least to influence the problem are called the **INDEPENDENT VARIABLES**.

---

*In a study of the relationship between knowledge of family planning methods and utilization of contraceptives, 'utilization of contraceptives' (with values 'yes' and 'no') would be the dependent variable and 'awareness of family planning methods' the independent variable.*

Whether a variable is dependent or independent is determined by the statement of the problem and the objectives of the study. It is, therefore, important when designing a study to clearly state which variable is dependent and which is independent.

Although in everyday language we may speak of possible causes of problems, in scientific language we prefer to speak of associations between variables, unless a causal relationship can be proven. Always remember that in science, you may have one condition present, which is necessary but not sufficient, for another phenomenon to occur. Looking for co-factors is part of scientific research. The existence of co-factors which contribute to the constitution of a certain problem or condition forces us to take the wider context of the problem into account.

## 5 Contextual and Confounding Variables

### *Demographic and Socio-Economic Variables*

In almost every study, contextual variables such as age, sex, ethnicity, educational level, socio-economic status, marital status, and religion appear. These contextual variables are also known as background variables. They are often related to a number of independent variables, so that they influence the problem indirectly (hence the term contextual or background variables). If the contextual variables are important to the study, they should be measured. However, in the interest of economy, try to keep the number of contextual variables to be measured to a minimum.

### *Confounding Variables*

Causal relationships are often very difficult to prove. One of the major dangers is that we assume a causal relationship between two variables, while in reality there is another variable related to *both* variables. Such an intervening variable is also called *confounding variable*.

---

A variable that is associated with the problem and with a possible cause of the problem is a potential **CONFOUNDING VARIABLE**. Another term sometimes used in the social sciences to describe a confounding variable is **INTERVENING VARIABLE**.

A **CONFOUNDING** (intervening) variable may either strengthen or weaken the apparent relationship between the problem and a possible cause.

---

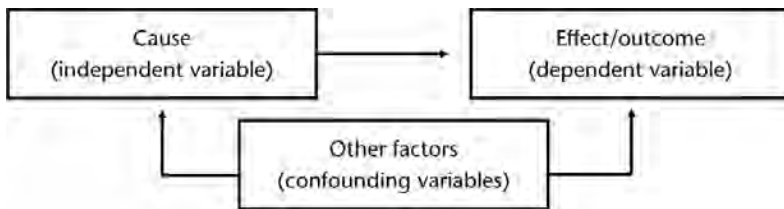

For example:

*In a case-control study, a relationship is shown between the low level of the mother's education and malnutrition in children under the age of five. However, family income may also be related to the mother's education as well as to malnutrition.*

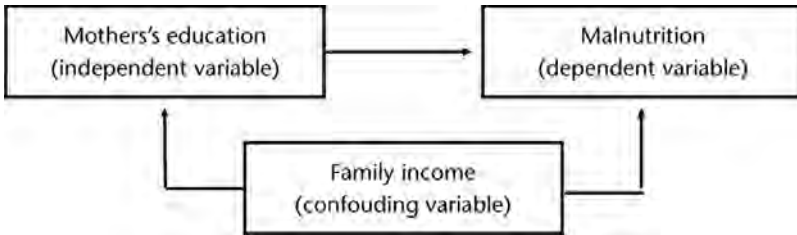

*In this case family income is a potential confounding variable. To give a true picture of the relationship between mother's education and malnutrition, family income must also be considered and measured.*

The researcher has to control for confounding variables. In case-control studies, this may be done to some extent beforehand, for example by selecting only mothers with a specific level of family income, or by matching both groups for expected confounding variables.

---

MATCHING means ensuring that the cases and controls are similar with respect to the distribution of one or more potentially confounding variables (for example age, income, education). In this procedure each subject in the study group is paired (MATCHED) with another subject in the control group for the particular confounding variable.

---

*Matching in our example would ensure that in both the case group and the control group the distribution of family income is even: for every low income mother in the case group, you would select a low income mother for inclusion in the control group.*

Ideally a researcher would like to match the cases and controls for all variables except the one(s) he is testing as associated factors. In practice this is neither possible nor advisable. You might, for example, 'match away' interesting variables and associations. There is another technique more used in social research available to control for confounding variables at the level of analysis afterwards: *stratification* (see Module 26).

---

STRATIFICATION involves making a separate analysis for different levels of the confounding variable (for instance: high, middle or low family income strata).

---

*By forming strata of high, middle and low income families the confounding variable will be taken into account, with mother's education and malnutrition among their children being analyzed between families with different categories of income.*

Unfortunately, social reality is even more complex. A single, simple cause – effect relationship almost never exists. A host of contextual factors may also influence the relation between two variables. Anthropologists usually do not use the term confounding variables, but instead point to the importance of contextualizing the problem at hand.

*In studying malnutrition, anthropologists would be interested in the variety of contextual factors related to the problem. They would want to know how these factors affect the relation between mother's education and malnutrition. These may include traditional and modern beliefs on appropriate infant feeding, access to information on appropriate feeding, access to health care, hygienic conditions in which the families live, and use of bottlefeeding can all be related to malnutrition.*

Since anthropologists often feel that it is not possible to identify one single cause of a health problem, they prefer to give a 'thick' (i.e. highly detailed) description of the interrelationship between various factors relevant to the problem.

### *Confounding Variables in Comparative Designs*

In any comparative study, one has to watch out for confounding variables. When a researcher compares two groups to study a phenomenon (for instance the incidence of a disease) it is of great importance to make sure that both groups are *comparable*, i.e. more or less equal in terms of many demographic and socio-economic variables. Otherwise the researcher might be comparing apples and pears which renders his/her conclusions unsound.

A Research team wishes to evaluate the effect of an intervention: an intensive training of mothers in Community A. For comparison the team selects community B where no intervention has taken place. In their analysis the researchers find that the frequency of malnutrition of under-5s is lower in community A than B. Can they now conclude that this difference is the result of the intensive training.

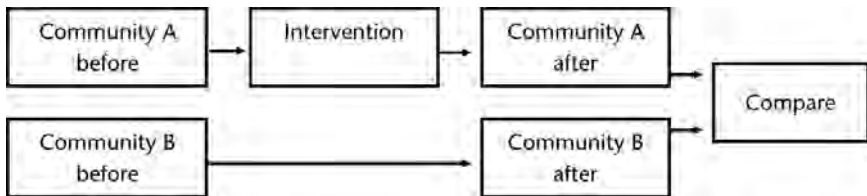

The answer is no. A relationship is shown between the low level of the mother's education and the malnutrition in under-5s. However, family income may be related to the mother's education as well to malnutrition.

*Family income is therefore a potential confounding variable. To give a true picture of the relationship between mother's education and malnutrition, family income*

should also be considered and measured. This could either be incorporated into the research design, for example by selecting only mothers with a specific level of family income, or it can be taken into account in the analysis of the findings, with mother's education and malnutrition among their children being analyzed for families with different categories of income.

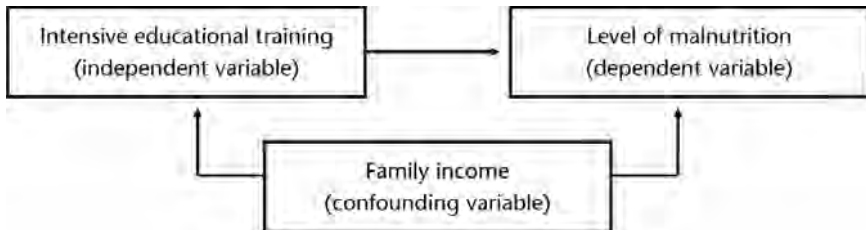

Unexpected factors beyond your control might have produced the same effect as the intervention you were studying, thereby making it impossible for you to know whether it was your intervention that produced the impact.

*During an AIDS awareness campaign launched by a community action research project in a poor black community in Chicago, the famous basketball player Magic Johnson publicly announced that he too was infected with HIV. This caused an enormous arousal of awareness, especially among young blacks in the United States. The action research project then decided that it was impossible to determine the extent of the effect of their own campaign before and after the intervention in the community, as they had originally intended.*

### Summary

Taking our analysis diagram as a starting point, we have to identify for our particular study:

- Which variables are related to each specific objective, and which are independent, dependent, confounding and contextual variables;
- Which variables can be measured as they are;
- Which variables need to be operationalized, by choosing indicators to measure them, and what definitions are needed for the variables and indicators that have been selected; and
- Which variables need further information to be defined adequately.

### *What are Validity and Reliability in Research Findings?*

---

VALIDITY refers to the degree to which scientific observations actually measure or record what they purport to measure.

---

Door-to-door interviewing about intimate details of respondents' sexual behaviour might produce a lot of answers duly recorded in interviewers' notebooks, but we would seriously doubt that the answers were an accurate representation of actual behaviour. Thus, such interviewing on sensitive subjects generally lacks in validity. Quantitative surveys are often criticized for producing invalid data, while the anthropological habit of long-term fieldwork in small communities – employing a variety of participant observation and interviewing situations – is generally thought to produce data with a high degree of validity.

---

RELIABILITY is often closely related to the matter of validity, but refers to the REPEATABILITY of scientific observations.

---

If the same set of door-to-door interviews on respondents' sexual behaviour produces approximately the same set of responses on repeated trials and with different interviewers, we can say that this observational technique has high reliability, regardless of the validity of the findings. It is possible to develop a reliable questionnaire which produces invalid responses! Most often, however, validity and reliability are interrelated.

Reliability (repeatability) refers to the possibility to *replicate* (repeat) the observations and is related to the precision of the instrument used for the scientific observations. Validity refers to the *soundness* of the observations, to the accurateness of the data collected by the research method / instrument. Validity is always a *relative* concept, while reliability, or rather: repeatability, can be measured. Most anthropological field work may be characterized by its concern with validity, sometimes at the expense of reliability. For Applied Health Research, however, we would like to emphasize that both high validity and high reliability in research are desirable because we would like the findings of our research to be not only scientifically sound (valid) but also generalizable (repeatable).

Researchers strive to increase validity and reliability of their methods and conclusions. This is often done by maintaining a 'mix' of research operations, often a blend of quantitative and qualitative methods, emphasizing both high validity and high replicability. This 'mix' of research methods is sometimes called triangulation and will be discussed in Module 17.



### *How to Deal with Threats to Validity and Reliability*

At various stages of the research validity and reliability could be threatened:

- At the moment of **selection** of the appropriate study type and design; distortion may occur during sampling or due to selectivity in assigning different subjects into various groups;
- At the level of the **data collection** (related to the instrument): the instrument itself may be unreliable; bias (distortion) may occur at various stages of data collection: interviewer-bias and Hawthorne effect (see footnote on next page);
- At the level of the **analysis** of the data collected: confounding variables or unexpected events may lead to misleading conclusions.

*Strategies to deal with threats to validity:*

- 1 *Control group.* Observing a control group who are not exposed to the risk factor or intervention reduces threats due to unexpected and confounding factors. It should be noted that in ΔHR it is often very difficult to identify and maintain a control group because the control group can become contaminated, i.e. exposed to the intervention through factors beyond the control of the researcher.
- 2 *Before and after measurements.*
- 3 *Appropriate sampling procedures.* This reduces threats due to selectivity.
- 4 *Unobtrusive methods of data collection* and allowing adaptation time for subjects to get used to being observed serve to reduce Hawthorne effects.
- 5 *Careful design and pretesting* of instruments reduce bias due to instrumentation.
- 6 *Stratification and matching* for confounding variables during the analysis of the results.

\* Hawthorne effect occurs when a group is being observed to determine the effect of an intervention. The observed change may be due to the fact that the group is being studied rather than due to the intervention.

## References

- Campbell, D.T. & J.C. Stanley  
 1963 *Experimental and Quasi-Experimental Designs for Research*. Chicago: Rand McNally.
- Hardon, A.P.  
 1991 'Confronting Ill Health: Medicines, Self-Care and the Poor in Manila.' The Philippines Health Action Information Network.
- Holland, W., R., Detels & G. Knox (eds.)  
 1984 *Oxford Textbook of Public Health. Volumes 1-4*. Oxford: Oxford University Press.
- Kelsley, J.L., W.D. Thompson & A. Evans  
 1986 *Methods in Observational Epidemiology*. New York: Oxford University Press.
- Kleinbaum, D.G., L.L. Kupper & H. Morgestern  
 1982 *Epidemiological Research*. Belmont: Lifetime Learning Publications.
- Kidder, L.H. & C.M. Judd  
 1987 *Research Methods in Social Relations*. Hong Kong: CBS Publishing Japan Ltd.
- McMahon, B. & T.F. Pugh  
 1970 *Epidemiology: Principles and Methods*. Boston: Little, Brown and Company.
- Moser, C.A. & G. Kalton  
 1979 *Survey Methods in Social Investigation*. Hants: Gower Publishing Company.
- Neeloy, Ashraful Alam Neeloy  
 2000 'Research Proposal: Care for the Elderly Poor. A Case Study of a Bangladeshi Village.' Research Proposal prepared for the AMMA Course, Amsterdam.
- Pelto, P.J.  
 1970 *Anthropological Research. The Structure of Inquiry*. New York: Harper & Row Publishers.
- Schlesselman, J.J.  
 1982 *Case-Control Studies*. New York: Oxford University Press.
- Yin, R.K.  
 1984 *Case Study Research: Design and Methods*. London: Sage Publications.

## Exercise

- 1 Look at your problem analysis diagram and give examples of numerical and categorical variables. Which variables can be measured directly and which ones need indicators before they can be measured?
- 2 Give an example of a dependent and an independent variable in your own proposal.

**MODULE 26**

**OVERVIEW OF  
DATA COLLECTION TECHNIQUES**

# OVERVIEW OF DATA COLLECTION TECHNIQUES

## Objectives

At the end of this Module, the participants should be able to:

- describe various data collection techniques applied in AHR and state their uses and limitations;
- state the benefits of using a combination of different data collection techniques;
- state various sources of bias in data collection and ways of preventing bias;
- identify ethical issues involved in the implementation of research and ways of ensuring that the research informants or subjects are not harmed by the study.

## Contents

- 1 Overview of Data Collection Techniques
- 2 Importance of Combining Different Data Collection Techniques
- 3 Bias in Information Collection
- 4 Maximizing Validity

\* Adapted from Module 10, Health Systems Research Training Series, Volume 2

## Overview of Data Collection Techniques

Data collection techniques allow us to collect systematically information about our objects of study (people, objects, and phenomena) and about the settings in which they occur. One must be systematic in the collection of data. If data are collected haphazardly, it will be difficult to answer the research questions in a conclusive way. In this Module an overview of various qualitative and quantitative data collection methods will be provided. The methods will be discussed in further detail in Modules 27-28 (Qualitative Data Collection Techniques) and Module xx (Quantitative Data Collection Techniques).

### 1 *Using Available Information*

Usually there is a large body of data already collected by others, although it may not necessarily have been analyzed or published. Locating sources and retrieving information is a good starting point in any data collection effort. The data can be quantitative (for example, data from statistics) or qualitative in nature.

*Content analysis* usually focuses on narratives, such as newspaper articles, folk songs, religious texts, diaries, and life histories. In general, the researcher has a theme in mind, otherwise it is difficult to structure the analysis. For example, she or he could skim through three years of a certain newspaper to observe how journalists have reported on AIDS, which themes have been covered and which not, how frequently, and whether there are any changes over time. Or, she or he could study specific Ayurvedic texts in search of a certain health belief's origin.

*Diaries and life histories* can also be very illustrative. There are numerous interesting and touching books in which patients suffering from terminal diseases relate how they cope with their disease or in which relatives relate how patients react to their disease and to treatment.

*Clinic and hospital records* are another source. Health centres and hospitals often have records that provide a wealth of information. Researchers can review data on vaccinations, for example, and gain insights on the effectiveness of the local area's immunization campaigns simply by looking at how many children are able to complete the recommended immunizations.

All these materials have to be analyzed in a structured manner. For quantitative as well as qualitative data one may use checklists or compilation sheets. In qualitative research, themes or issues are identified which will have to be ordered meaningfully.

### 2 *Observation*

---

OBSERVATION is a technique that involves systematically selecting, watching, and recording behaviour and characteristics of living beings, objects, or phenomena.

---

Observation of human behaviour is a much-used data collection technique. The observer may participate in the situation or activity she or he is observing in various degrees. If she or he participates this may be done quite openly or the researcher may choose to conceal that specific identity. This would be *unobtrusive observation*.

*High degree of participation* is another possibility. (In the following examples concealment is intended but depends on the recognizability of the researcher as an outsider): Medical staff who themselves become patients in a hospital; a social scientist who dresses as a football fan and mixes with the public to observe the behaviour of fans, or who goes to a beer hall to observe whether or not people share drinks with leprosy patients. Note that you can also tap peers to do research, e.g., train young people to observe their peers and to document what they observe.

An example of *low degree of participation (no concealment obtrusive)* would be an anthropologist who is allowed to attend a session held by a traditional healer.

*No participation (concealment unobtrusive)* could take the form of a psychologist who observes the playing behaviour of children behind a glass wall which is only transparent from her or his side.

Observations may serve different purposes. They can give additional, more accurate information on people's behaviour than interviews or questionnaires: questionnaires may be incomplete because one forgets to ask certain questions and informants may forget or be unwilling to mention certain things. Observations can, therefore, check on the information collected, especially on sensitive topics such as alcohol or drug use, or stigmatized groups such as people with leprosy, tuberculosis, epilepsy, or AIDS. In some cases of research, observation may be a primary source of information, especially for assessing the quality of care in health centres and hospitals. The observers may use additional tools such as video recorders. Observations can also be made of objects. For example, the presence or absence of a latrine and its state of cleanliness may be observed. Also, a researcher may count the number of times a syringe or a needle is used before it is sterilized. Observations can thus be qualitative and/or quantitative in nature.

Observations of human behaviour can form part of any type of study, but as they are time-consuming they are most often used in small-scale studies. Module 28 will deal further with participant observation and some of its advantages and methodological problems.

### 3 Interviewing

---

An INTERVIEW is a data collection technique that involves oral questioning of respondents, either individually or as a group.

---

Answers to the questions posed during an interview can be recorded by writing them down (either during the interview itself or immediately after the interview) or by tape recording the responses.

Interviews can be conducted with varying degrees of flexibility. The two extremes, high and low degrees of flexibility, are described below:

- *High degree of flexibility* (semi-structured or unstructured interviews): In these interviews an interview schedule is used to ensure that all issues are discussed, but at the same time, flexibility in timing and the order in which questions are asked is allowed. The interviewer may ask additional questions on the spot to gain as much useful information as possible. Questions are open-ended: the respondent is unrestricted in what and how she or he answers. A highly flexible form of interview is the ethnographic interview.

This semi-structured or loosely structured method of asking questions can be used for interviewing individuals as well as groups of key informants.

A flexible method of interviewing is useful if a researcher has as yet little understanding of the problem or situation he or she is investigating. It is frequently applied in exploratory studies and case studies. A researcher will usually start with a number of key informants who are highly knowledgeable on various aspects of the investigation.

- *Low degree of flexibility* (structured interviews and questionnaires): In structured interviews, a questionnaire is used with a fixed list of questions that have mainly fixed or pre-categorized answers in a standard sequence. Less flexible methods of interviewing are useful when the researcher is relatively knowledgeable about expected answers and when the number of respondents being interviewed is large. Structured questionnaires are also necessary when statistical analysis is required.

#### 4 *Self-Administered Questionnaires*

---

A WRITTEN QUESTIONNAIRE (also referred to as self-administered questionnaire) is a data collection tool in which written questions are presented that are to be answered by the respondents in written form.

---

A written questionnaire can be administered in different ways, for example by:

- sending questionnaires by mail with clear instructions on how to answer the questions and asking for mailed responses;
- gathering all or part of the respondents in one place at one time, giving oral or written instructions, and letting the respondents fill out the questionnaires; or
- hand-delivering questionnaires to respondents and collecting them later.

The questions can be either open-ended or closed (with pre-categorized answers). See Module 30 for details concerning the design of interview schedules and questionnaires.

#### 5 *Focus Group Discussions (FGD)*

Focus group research involves organized discussions with a selected group of individuals to gain insight on their views, feelings, beliefs and experiences regarding a certain topic. In comparison with an individual interview, the advantage is that some ideas, experiences, and feelings are more likely to be revealed in the interaction within a group.

Although the opposite might be true as well: people may not be very willing to share certain kind of information, depending on, for example, the composition of the group and the meaning and sensitivity of the topic under discussion. When using focus group discussions (FGDs) – ideally – the researcher is no longer the centre of the activity, rather, she/he lets informants discuss with each other. The researcher merely facilitates the discussion. However, such a situation is not always easy to achieve. It requires special skills from the facilitator and clear instructions to the participants of the FGD, in order to avoid having the FGD become a group interview, i.e. the emphasis being on questions and responses between the researcher and participants. In Module 28 some instructions are given on how to conduct a focus group discussion.

### *Narrative Research Method*

The narrative research method grew out of a need expressed by those responsible for programmes for young people. It aims at describing realistic patterns of adolescent behaviour, a goal which was difficult to achieve through more conventional research methods. There are different ways of conducting such research. The WHO and others have applied the narrative research method in three phases in several African countries.

- First, a workshop is held with youth leaders to identify key events typically experienced by young people in their communities between puberty and childbearing or marriage. For example, for sexuality, significant events experienced by teenagers might be 1) the first encounter between two young people that leads to a more serious relationship; 2) the first confrontation with parents about ‘dating’, and (3) the first sexual experience. Two volunteers then roleplay a scene, and participants offer their opinions, suggest alternative ways, and discuss the motives and intentions of the characters. A story is developed which may cover several years in the lives of the adolescents involved. Based on this story a kind of questionnaire is produced.
- In the second phase the youth workers take stories and questionnaires to the field, targeting young people of both sexes. The stories are read or played, questions are asked (individually and/or in groups) and rapporteurs note the answers, reactions and discussions.
- In the last phase another workshop is held with the same youth workers who jointly discuss and analyze the findings. They present charts, showing the most common choices made at each stage in the story by different respondents. Differences between groups (age, sex, urban/rural) are identified by item, and the meaning of their findings as a basis for programme and project development are discussed. The findings of such a study can be roleplayed live (or on video tape) in front of key audiences of influential policy-makers, parents, teachers, community leaders and religious figures, in order to increase the study’s impact (adapted from WHO [1993]).

### *Projective Techniques*

When a researcher uses projective techniques, she or he asks an informant to react to some kind of visual or verbal stimulus.



The informant may be provided with a set of pictures of different sanitary conditions and be asked to react. Another possibility is to present the informant with different types of medicines, ask him/her to arrange these into piles and then explain the logic behind the piles.

Another example of a projective technique is the presentation of hypothetical questions and cases to an informant. A researcher may ask the informant to complete sentences, such as:

- If I would discover that my neighbour has TB I would ..... ;
- If my wife would propose to use condoms I would .....

Or she or he may ask the informant ‘Suppose your child suffered from diarrhoea; what would you do?’

Such techniques can easily be combined with semi-structured interviews or written questionnaires.

### *Differentiation between Data Collection Techniques and Data Collection Tools*

To avoid confusion in the use of terms, the following table points out the distinction between techniques and tools applied in data collection.

**Table 26.1** Data Collection Techniques and Tools

<i>Data Collection Techniques</i>	<i>Data Collection Tools</i>
Using available information	Checklist, data compilation forms
Observing	Eyes and ears, pen and paper, watch, tape or video recorder etc.
Interviewing	Interview schedule, checklist, questionnaire, tape recorder
Administering written questionnaires	Questionnaire
Organising focus group discussions	Discussion guide, tape recorder
Using narrative research methods	Stories and questionnaires
Using projective techniques	Visual aids, sentence completion forms, hypothetical cases

### *Advantages and Disadvantages of Various Data Collection Techniques*

Table 26.2 summarizes the advantages and disadvantages of the major data collection techniques as discussed above.

**Table 26.2** Advantages and Disadvantages of Various Data Collection Techniques

<i>Technique</i>	<i>Advantages</i>	<i>Disadvantages</i>
<i>Using available information</i>	<p>Inexpensive, because data are already there.</p> <p>Permits examination of past trends.</p>	<p>Data are not always easily accessible.</p> <p>Ethical issues concerning confidentiality may arise.</p> <p>Information may be imprecise or incomplete.</p>
<i>Observing</i>	<p>Gives more detailed and context-related information.</p> <p>Permits collection of information on facts not mentioned in the questionnaire.</p> <p>Permits tests of reliability of responses to questionnaires.</p>	<p>Ethical issues concerning confidentiality or privacy may arise.</p> <p>Observer bias may occur (observer may notice only what interests him or her).</p> <p>The presence of the data collector can influence the situation observed.</p> <p>Thorough training of research assistants is required.</p>
<i>Interviewing</i>	<p>Suitable for use with illiterates.</p> <p>Permits clarification of questions.</p> <p>Higher response rate than written questionnaires.</p>	<p>The presence of the interviewer can influence responses.</p> <p>Reports of events may be less complete than information gained through observations.</p>
<i>Semi-structured flexible interview</i> (small-scale; open ended questions)	<p>Permits collection of in-depth information and exploration of spontaneous remarks by respondents.</p>	<p>The interviewer may inadvertently influence the respondents.</p> <p>Open-ended data are difficult to analyze.</p>
<i>Structured interview</i> (larger-scale; closed questions)	<p>Easy to analyze because of fixed categories of answers.</p> <p>Statistical analysis is possible.</p>	<p>Important information may be missed because spontaneous remarks by respondents are usually not recorded or explored.</p> <p>Lack of validity.</p>

<i>Technique</i>	<i>Advantages</i>	<i>Disadvantages</i>
<i>Self-administered written questionnaires</i>	<p>Less expensive.</p> <p>Permits anonymity and may result in more honest responses.</p> <p>Does not require research assistants.</p> <p>Eliminates bias due to phrasing questions differently with different respondents.</p>	<p>Cannot be used with illiterate respondents.</p> <p>There is often a low rate of response.</p> <p>Questions may be misunderstood.</p>
<i>Focus group discussion</i>	<p>Provides possibility to pursue issues that came up in individual interviews.</p> <p>Is a relatively 'fast' method to learn about different perspectives on issues.</p> <p>Provides possibility for joint evaluation of interventions.</p>	<p>People may be reluctant to talk in each other's presence about sensitive topics.</p> <p>Is not suitable if researcher is interested in actual behaviour because FGDs generate group norms rather than individual ideas and practices.</p> <p>Sometimes the results are only meager as the group discussion dynamics do not take off.</p>
<i>Narrative Research Method</i>	<p>Deals with issues that are really relevant for target group.</p> <p>The research process itself is already an intervention that raises awareness among target group members.</p> <p>Requests true involvement of the target group in all phases of research. This enhances commitment in the intervention phase.</p>	<p>Conducting roleplays require facilitators with good skills in group dynamics.</p> <p>Care should be taken that the research process and the outcomes are carefully reported to policy-makers and others involved.</p>

## 2 Importance of Combining Different Data Collection Techniques

When discussing different data collection techniques and their advantages and disadvantages, it becomes clear that they can complement each other. A skillful use of a combination of different techniques can maximize the quality of the data collected and reduce the chance of bias (see below). The combination of different techniques is called *triangulation*.

Researchers often use a combination of flexible and less flexible research techniques.

*In a certain area it was observed that young children often do not eat enough food during and after an illness episode. From a nutritional standpoint, young children need extra calories in order to recover from illness to make up for the energy losses and lack of appetite during the illness episode. Without these extra calories a child's resistance may be weakened and the child's growth could be negatively affected (this process is sometimes called stunting). This may result in a vicious circle of repeating illnesses and malnutrition.*

*A study could be designed to address this problem, containing the following stages:*

- *To determine the extent of the problem, the researchers could make use of growth charts and the existing health centre records of malnourished children in the area;*
- *Focus group discussions (FGDs) with several groups of mothers and/or in-depth interviews with a small group of mothers to find out how they feed their young children during and after episodes of different illnesses and how they deal with children who have no appetite when they are sick. During this stage the researchers could use projective techniques such as hypothetical illness cases. This could be the exploratory study;*
- *A household survey, testing the relevant findings of the exploratory study on a larger scale;*
- *FGDs with women in the study area to discuss findings and possible questions arising from the survey and to develop possible solutions for the problems detected.*

In this example, the exploratory, qualitative part of the study would be used to focus the subsequent household survey on the most relevant issues and to help phrase the questions in an optimal way in order to obtain the information that is needed.

The second, quantitative part of the study would be used to find out what proportion of the mothers follow various practices, the reasons for their behaviour, and whether the problem is more prevalent among certain categories of children, e.g. the younger ones or children from specific socio-economic categories.

The third, qualitative part of the study would provide feedback on the major findings of the survey. Do the conclusions make sense to women in the study area? Have certain aspects been overlooked when interpreting the data? What remedial action is feasible to improve the feeding practices of sick children?

This example shows how various methods can be used in subsequent research phases to complement each other. It is also common to collect both qualitative and quantitative data in a single questionnaire. Researchers collecting both types of data have to take care that they:

- do not include too many open-ended questions in large-scale surveys, making data analysis difficult; and
- do not use inappropriate statistical tests on quantitative data generated by small-scale studies.

The combination of different techniques at the same time, or triangulation, is a basic characteristic of Rapid Appraisal Techniques. Rapid appraisals are usually carried out by multi-disciplinary teams which use flexible research techniques requiring a high degree of interaction among themselves as well as with the target group. Rapid appraisals can be used in a more or less participatory way, including the target group in the design, implementation and analysis.

### 3 Bias in Information Collection

---

BIAS in information collection is a distortion or a systematic error in the design or conduct of a study that results in the information not being representative of the situation.

---

Bias affects both the validity and reliability of the study. Possible sources of bias during data collection are:

#### *Defective Instruments*

Bias can be produced by unreliable instruments such as:

- using a weighing scale which is not adjusted to zero;
- using a door-to-door survey to investigate the extent of condom use.

In questionnaires, bias can also be produced by:

- fixed or closed questions on topics about which too little is known;
- open-ended questions without guidelines on how to ask (or answer) them;
- vaguely phrased questions; or
- questions placed in an illogical order.

Another example of bias is called *instrument reactivity*: the instrument itself has an effect on the subjects and produces a distorted response:

- in a survey on alcoholism, the researcher asks school children ‘Is your father an alcoholic?’

These sources of bias can be prevented by carefully planning the data collection process and by pretesting the data collection tools.

### *Observer Bias*

Observer bias can easily occur during observation or loosely (semi-)structured group or individual interviews. There is a risk that the data collector will see or hear only the things in which he or she is interested or will miss information that is critical to the research. Observation protocols and guidelines for conducting semi-structured interviews should be prepared, and training and practice should be provided to data collectors in using both these tools. Moreover, it is highly recommended that data collectors work in pairs when using flexible research techniques and discuss and interpret the data immediately after collecting it.

### *Selection Bias*

If a large proportion of the population under study refuses to cooperate (non-response) or if the sampling procedure used in the study is inadequate, this results in *selection bias*. This type of bias affects the representativeness of the study and will be discussed at length in Module 32. Non-response may distort the research results in a positive or a negative way.

*In a survey trying to establish the prevalence of sexually transmitted diseases (STDs) among men, it was found that many men refused to answer certain questions regarding extra-marital sexual relations and visits to STD clinics. It is possible that these men feared the consequences of disclosing such sensitive information to outsiders. The researchers may therefore underestimate the prevalences of STDs in the community.*

It is always wise to investigate the reasons for non-response since this may give the researcher some important clues about the topics being researched.

*Quijano (1992) developed a questionnaire to interview general practitioners in the private sector in The Philippines about their drug prescribing practices. He selected a large sample of 315 GPs, both inside and outside the metro Manila area. Only 129 questionnaires were accomplished. About 90 GPs flatly refused to answer the questionnaire, many of them expressing distrust and some were outrightly belligerent. Another 50 questionnaires were reported 'lost'. Such a large proportion of refusals indicates that the results of Quijano's research were biased. Nevertheless, he concludes that his study showed grossly irrational prescribing behaviour by medical practitioners. According to the answers of the questionnaire, consultation with a physician almost always results in drug prescription, even for the most trivial complaints.*

---

## Questions

Do you think that Quijano's conclusion is justified? How did the selection bias affect the results of his study? Could you think of ways to improve the validity of Quijano's study?

---

High non-response or refusal rates are usually a meaningful sign for a researcher.

*The example of the non-response of doctors in The Philippines (Quijano 1992) clearly demonstrated the reluctance of medical professionals to discuss their prescribing practices, which they saw as something confidential which should not be discussed with outsiders or lay people. Some doctors even defended their so-called 'right to prescribe'.*

Selection bias may also occur due to drop-outs in prospective, comparative study designs. The type of subjects who drop out of the study or control groups may be related to some of the characteristics being studied.

*You are studying the effectiveness of a nutritional programme for malnourished children by comparing the average weight gain in the programme group with that of a control group. However, a number of mothers in the programme group found the programme too demanding and have dropped out. This did not occur in the control group.*

This form of selection bias is also known as *differential subject loss* in the various groups.

## Information Bias

Information bias may occur while abstracting information from records or statistics. Often, medical records are incomplete, illegible or incomprehensible. This poses some problems if the researchers want to use these records in the research.

Another example of information bias is called *recall (or memory) bias*. This form of bias is related to inconsistencies in informants' memories. Most people are not able to recall accurately minor events such as common illnesses that happened some weeks ago. If a researcher asks the question: 'Did you or any of your family members receive an injection in the past year?' the answers may be unreliable or incomplete. Memory bias can be minimized if the period of recall is limited. It is therefore advisable to ask questions that require only a short period of recall: it is generally advisable to use a recall period not longer than two weeks. The question about the prevalence of injections could therefore better be phrased as: 'Did you or any of your family members receive an injection in the past two weeks?'

### *Effect of the Interview and/or Interviewer on the Informant*

This is a factor in all interview and research situations. In Module 25 we briefly mentioned the Hawthorne effect: a change in group behaviour due to the fact that it is being studied. In an interview situation a similar effect may occur. The informant may mistrust the intention of the interview and dodge certain questions or give misleading answers. Such bias can be reduced by adequately introducing the purpose of the study to informants, by taking sufficient time for the interview, and by assuring informants that the data collected will be confidential.

Another important point is the interviewer's behaviour and style of interviewing. A bossy style may put off the respondent or may lead him or her to lean towards giving answers which she or he expects to be 'desired' by the interviewer.

It is always important to be careful in the selection of interviewers. In a study soliciting the reasons for the low utilization of local health services, for example, one should not ask health workers from the health centres concerned to interview the population. Their use as interviewers would certainly influence the results of the study. The same will be the case if interviewers are recruited from a class of wealthy peasants for a study among poor peasants. The same principle could be applied to a study of doctors. In this case it is advisable that the interviewers are medical graduates as well since doctors are often unwilling to discuss their practices with non-doctors. Differences in class, gender, social status and profession between informants and interviewers are important reasons for bias in research situations.

To conclude: there are many forms of bias. By being aware of the potential biases mentioned above, it is possible, to a certain extent, to prevent them. However, since every researcher has his or her own expectations, preferences and interests, a study is never totally free from observer bias. Also, since an interview always has an effect on the informant, this type of bias can also not be avoided.

Since bias can never be banned completely from any study design, it is always best to report honestly what the researcher has done to prevent bias as much as possible and in what ways the data may still be biased.

## **5 Maximizing Validity**

When conducting research one should aim at collecting valid and reliable data. In Module 25 validity was defined as ensuring that the collected data reflect the reality to which the research questions are directed.

All sources of bias which were discussed in the previous section – defective instruments, observer bias, effects of the interview on the informant – can lead to invalid and unreliable data.

A proper strategy to maximize validity is triangulation: the combining of different data collection methods. The data collected with the various methods can be compared for inconsistencies. If an inconsistency is discovered, its source has to be found. Invalid data must always be discarded. After adjusting the data collection method which has led to invalidity, or by using a new method, additional data will probably have to be



collected. Large refusal rates, resulting in selection bias, may indicate that the data collection method was not suited for the purpose of the research.

*In the example of the high non-response rate among men in a survey on the prevalence of STDs in a community one could improve the research's validity by adding other research methods, such as observations in STD clinics, in-depth interviews with key informants such as doctors, drug sellers and prostitutes and their clients. Records of STD clinics could also help to determine how often certain illnesses are detected.*

Reliability of the research instruments can be improved by precision and by pretesting the research tools. In the design of questionnaires, for example, much time has to be devoted to the precise, concrete and unambiguous phrasing of questions.

## References

Chambers, R.

- 1985 'Shortcut Methods of Gathering Social Information for Rural Development Projects.' In: Michael C. Cernes (ed.), *Putting People First: Social Variables in Rural Development*. New York & London: Oxford University Press.

Chambers, R.

- 1990 'Rapid but Relaxed and Participatory Rural Appraisal: Towards Applications in Health and Nutrition.' Paper presented at the International Conference on Rapid Assessment Methodologies for Planning and Evaluation of Health Related Programs. Washington DC, Nov. 12-15 1990.

Marshall, P.

- 1991 'Research Ethics in Applied Medical Anthropology.' In: C.E. Hill (ed.), *Training Manual in Applied Medical Anthropology*. Washington, DC: American Anthropological Association, Special Publication No. 27.

Pelto, P.J. & G.H. Pelto

- 1978 *Anthropological Research. The Structure of Inquiry. Second Edition*. Cambridge: Cambridge University Press.

Quijano, R.F.

- 1992 'Prescribing Habits and Attitudes of Medical Practitioners in the Philippines.' *Drug Monitor* Vol. VII (2): 15-27.

WHO

- 1993 *The health of young people. A challenge and a promise*. Geneva: WHO.

## Exercise

### *Selection of Study Types and Data Collection Techniques*

Four health-related problems for which studies must be developed are described below. For each problem you are asked to state:

- what type(s) of study you would propose (see Module 15);
  - from whom (or from what) you would collect the data required for each study; and
  - what data collection techniques you would use.
- 1 A district health team evaluated its malaria spraying programme by looking at available records and reports and did not find significant flaws in the functioning of the services in different divisions and villages. Nevertheless, the incidence of malaria and mosquito counts show peaks in certain villages that are most likely related to differences in quality of the malaria spraying services. You want to find out if there is something wrong with the services.
  - 2 In a rural district it was noted that the number of low birth-weight babies was comparatively high and you have been asked to do research on the socio-cultural and socio-economic conditions of the mothers to find out the reasons and to determine what remedial action should be undertaken.
  - 3 You have recently been appointed as District Research Officer in a remote district. The government wants to improve health services in this area. One of your tasks is to assist in the development a district health plan. You want to collect information that will contribute to the development of the plan.
  - 4 There are long queues (waiting times) at the out-patient department of your district hospital. It is necessary to find out to what extent the problem may be related to the organization and management of the department and whether certain bottlenecks can be identified. In a later stage of the research the management would like to try to eliminate some of the bottlenecks and see whether there is improvement. You are asked to carry out applied research on the problem.
-

---

## Assignment

Decide what study types and options for study design you will apply in your own research proposal. Make your choice on the basis of your research questions and the variables you would like to include in the study.

Determine what data collection techniques you will use.

Decide whether there are any ethical problems with your study design or data collection tools you propose.

---



**QUALITATIVE DATA COLLECTION TECHNIQUES I:  
ETHNOGRAPHIC TECHNIQUES**

# ETHNOGRAPHIC TECHNIQUES

## Objectives

At the end of the Module, the participants should be able to:

- understand ethnographic techniques;
- describe the different types of questions used for ethnographic interviewing and understand how ethnographic interviewing differs from the use of survey questionnaires;
- describe how participant observation can be used in research, especially in relation to identifying contextual factors affecting behavior;
- distinguish different parts of an ethnographic record.

## Contents

- 1 Introduction
- 2 Choosing Informants
- 3 Ethnographic Interviewing
- 4 Participant Observation
- 5 Drawing Out Context

## 1 Introduction

Ethnography is derived from two Greek words: *ethnos* (people) and *graphein* (to write). It means writing about or describing peoples and cultures. Ethnography is both a science and an art. It requires an ability to listen and to learn, to be sensitive to what people are saying. It is based on sharp observation of what is going on. Ethnography, in turn, allows for a scientific study of cultures or ethnology, which gives us new insights into problems and solutions.

Ethnography actually employs many different methods such as interviews, observation, oral history, folklore analysis, focus group discussions, and surveys. The methods complement each other to improve validity of the information gathered.

In this Module, we will emphasize the use of ethnographic interviewing methods, which are important complementary tools to the more quantitative surveys to be discussed in Module 19. We will also discuss other ethnographic techniques such as participant observation, and the writing of field notes.

What are the differences between ethnographic interviewing and a survey utilizing questionnaires?

- Ethnographic studies often require more time in the field to gather information. This is because ethnographers are interested in gathering as much detailed information as possible. Since time and budgetary constraints may prevent a long stay in the field, there have been attempts to develop methods that still use ethnographic techniques but involve shorter periods in the field (*Rapid Appraisal Procedures*). These ‘short cuts’ involve a focus instead of trying to gather data on everything that goes on. Two forms of rapid ethnography are *focused ethnographic interviews* and *focus group discussions*. Focus group discussions will be discussed separately in Module 28.
- Ethnographic techniques involve an observation of the wider context of people’s lives. This includes the social and the natural environment. Thus, even in rapid assessment, it is important for the researcher to gather as much background information as possible while retaining a focus on a particular issue or topic.
- Ethnographic techniques are interested in the ‘native’ (emic) point of view. The use of the local language is not just a medium through which information is exchanged; instead, language itself becomes information. Local words and descriptions are recorded as is. A translation into English can be provided when you are doing a write-up but key words should be retained in the original language since many words cannot be accurately translated from one language to another.
- Because of our interest in the native point of view, in ethnographic research it is preferred not to speak of a ‘researcher’ and a ‘respondent’ but of an ‘ethnographer’ and his ‘informant’.

## 2 Choosing Informants

Ethnographic techniques do not rely on rigid sampling methods as one would find for surveys. However, it is important to decide on who your informants will be. Ethnographers often rely heavily on *key informants*. These are individuals who are presumed to be knowledgeable about the research topics. Often, the selected key informants are officials in a community, or older people. In a maternal and child health research project, it is logical to presume that mothers should be the key informants.

However, one has to be careful with presumptions about key informants. Research on maternal and child health should not necessarily be limited to mothers. In many societies, young mothers depend very much on the advice of older women, such as their mothers or mothers-in-law, in matters of child health. In others, the husbands decide on health seeking matters. A fieldworker's most important informants are frequently persons who occupy specialized positions in local society. Apart from the advantages such as obtaining detailed information from those 'who know' it may give a biased picture of events. Relying on village officials may exclude other important views and opinions of those with less power and of less prominent social status.

In the final analysis, it is always best to obtain information from a 'core' group of informants, for example mothers, but to supplement the information by interviewing other people and using other ethnographic methods such as observation of day-to-day activities in the community. Key informant interviewing is used to best advantage when it is closely integrated with participant observation.

## 3 Ethnographic Interviewing\*

### *Elements of Ethnographic Interviews*

Ethnographic interviewing is one of the most important techniques in ethnography. Ethnographic interviews and discussions often resemble day-to-day conversations. Instead of throwing out questions in rapid succession, as in formal interviews and surveys, an ethnographic interview allows for longer questions and 'probing'. The ethnographer can go back and review points that are not clear while the informant is more spontaneous in his or her answers. Sometimes, the informant may even ask the ethnographer questions. This indicates that in ethnographic interviews the hierarchy between researcher and research subject is less apparent than in formal interviewing situations.

There are obvious advantages in using ethnographic interviewing, mainly that of gathering information that cannot be obtained from more structured interviews or surveys because of the complexity and sensitivity of the issues.

*If we rely only on surveys for research on the income of women, we may end up limiting the information that can be derived. Women whose work is mainly agri-*

\* This section is based on: J. Spradley (1979): *The Ethnographic Interview*. New York: Harcourt Brace Jovanovich.



*cultural, for instance, may not be able to put a cash value on their work. Ethnographic interviews allow a probing into the different types of women's labour, including their own ways of assessing the value of such labour.*

Ethnographic interviews are meant to draw out *categories of meaning*, eliciting what people think, and how one person's perceptions compare with another's. The purpose is to map out shared values in the community, and more specifically, values that influence behavior.

The quality of information obtained from an ethnographic interview depends on how much structure and focus is built into the methodology. There are three main elements that allow this structure and focus:

- 1 *Presence of an explicit purpose.* Both the ethnographer and the informant are aware of a topic or topics of interest. This keeps the discussion more or less focused although the researcher should also learn to be flexible enough to move to other topics that may turn out to be important. Explaining the purpose of your research is an important ethical consideration. Properly introducing yourself, and the research objectives, allows you to obtain informed consent.
- 2 *The use of ethnographic explanations.* The ethnographer introduces the purpose or purposes of the interview at the start of a session and repeats these objectives from time to time to keep the discussion focused, or to introduce new questions. For example, in doing research on economic status of women, one might start a discussion on marriage but the ethnographer should explain that the discussion of marriage is meant to generate insights into women's economic status. Without explaining the research's focus, the person being interviewed might feel that the questions are intrusive or irrelevant.

A good ethnographer should also explain what he or she is doing. If notes are being taken, or if a tape recorder is being used, you should explain why you are doing this. All research projects require guarantees of confidentiality, so this should be stressed when you ask permission to take notes or to tape the session. These explanations are especially important when you are working in an area that may be affected by political conflict. Any person asking many questions, and using tape recorders, cameras or maps, may be suspected of gathering information for political purposes.

- 3 *The use of ethnographic questions.* There are three main types of ethnographic questions used to collect information:
  - structural questions;
  - descriptive questions;
  - contrast questions.

These questions supplement each other. There is no 'correct' sequence on using the questions since one moves back and forth according to the flow of the discussion and the objectives of the interview session. As mentioned earlier, ethnography is both a science and an art. The only way to learn to ask the questions is to try them out. Below, we

present some examples of how to start each type of question. In a real interview situation, the questions should be put in a more conversational tone.

### *Ethnographic Questions*

#### *Structural Questions*

These tend to be more general questions that give you a framework for deeper discussion. For example, you can ask the informant: 'What have you heard about how AIDS is spread around?', which results in a list of answers. The items named then allow you to ask more specific descriptive questions.

Sometimes, one can also ask 'verification' questions. For example, an informant may have named what (s)he knows about the modes of HIV transmission: 'sex, blood transfusion, mosquitoes.' After having discussed sexual modes of transmission, the researcher can go back to the original list and ask: 'Did you mention mosquitoes earlier?' This allows you to shift the focus of the interview while verifying an earlier statement from the informant.

#### *Descriptive Questions*

There are several types of descriptive questions. All of these allow for in-depth probing of answers that came from the structural questions:

- a *General* – This is somewhat similar to structural questions but here you are trying to create a focus. For example, in a discussion of illnesses transmitted by insects, you can ask for the informant's knowledge of illnesses spread by flies, and then by mosquitoes, and so forth.
- b *Experiential* – It is often useful to ask the informant to talk about their own experiences: 'Can you tell me, from your own experience, how you prepare an oral rehydration drink?' In some instances, you may even ask your informant to actually show you how (s)he would prepare the rehydration drink. Actual demonstration helps to narrow down the gap between knowledge and practice, i.e., while some informants may be very good at describing a certain technique, this may not always translate into actual skills. Or, the informant may be quite skilled but may not express himself or herself if you ask for a verbal description.

Experiences need not be first hand. You can also ask the informant about what they know about other people's experiences: 'Since you have never tried preparing the oral rehydration drink, what have you heard from your friends or neighbours who have tried preparing that drink?' Asking for 'second-hand' information can also be a good way of asking sensitive questions, e.g.: 'Have you heard of other women's experiences with abortion? What were their experiences?'

Experiential questions are especially important in intervention research because informants can explain their reasons for doing or not doing something, based on their own experiences. You could, for instance, ask a mother to talk about her experiences with hospitals. Quite often, as she explains her experiences you will find out the reasons for people using, or avoiding, a hospital.

- c Hypothetical* – If an informant does not have any experience about a situation, you can also pose a hypothetical situation: ‘What would you do if you found out that a neighbour had tuberculosis?’
- d Native language descriptions* – Even if both the ethnographer and the informant are speaking in the same language, there may be cases where there are terms that are specific to a village, or to a sub-culture. People may have specific terms for sexual activities. You can ask them about these terms: ‘What terms do you use to refer to sexual intercourse?’ It is very important to retain all these local terms. If you translate them to other dialects or languages, be sure to cite the original terms.

### *Contrast Questions*

Sometimes, it is useful to use contrast questions to highlight important differences. They can involve two items or two situations: ‘How would you differentiate the fever in malaria from other fevers?’ Or, they can involve three situations: ‘What is the difference between this medicine and the two other medicines you described earlier?’

An ethnographic session moves back and forth among these questions. You ask, then clarify, then perhaps repeat a question or go back to an earlier answer for more details. Periodically, you also have to incorporate and synthesize the views that have been obtained to allow you to move on to another topic while keeping a logical flow.

## 4 Participant Observation\*

Ethnography does not just involve interviewing. *Participant observation* is an important complementary tool to interviewing, especially if you are to understand the context of what people say in the interviews. Participant observation is also essential for checking and evaluating key-informant data. A field project usually consists of a continuous interplay between participant observation and other modes of data collection.

Originally, the style of social science research involved an ‘outsider’ coming into a village and observing activities there as an objective, detached researcher with minimal involvement with the community. Anthropologists working in the field for extended periods of time found that you could get much more information by using participant observation, i.e., by actually participating in the natives’ activities.

The rationale here is to learn to see and interpret the world from the people’s own perspective through intensive interaction: by participating in many of the day-to-day activities. All human beings act as ordinary participants in many social situations.

The participant observer, however comes to a social situation with *two* purposes: to engage in activities appropriate to the situation and to observe the activities, people, and physical aspects of the situation (Spradley 1980: 53-62). The ordinary participant in a social situation usually experiences it in a subjective manner: as participants, we are

\* This section is based on J. Spradley (1980): *Participant Observation*. New York: Holt, Rinehart and Winston.

*inside* the situation. The participant observer, on the other hand, will experience being both an insider and outsider simultaneously. Doing ethnographic fieldwork involves alternating between the insider and outsider experience, and having both simultaneously.

Participant observation builds on many basic principles that we have discussed at the start of this course, particularly cultural relativism. It means recognizing that different cultures have different ways of interpreting the world around us, and to understand some of the reasons for these differences. It also means becoming explicitly aware of the tacit cultural rules that guide our behaviour and of the meaning of routine, ordinary activities. As a participant observer, you will need to increase your *introspectiveness*, i.e. your ability to look within yourself how you feel about particular experiences. You will learn to use yourself as a research instrument. This introspection of ordinary activities contrasts sharply with the ordinary participant who has learned to take the experience for granted. Introspection may not seem ‘objective’, but it is a tool all of us use to understand new situations and to gain skill at following cultural rules.

The last crucial difference between an ordinary participant and the participant observer is that the latter will keep a detailed *record* of both objective observations and subjective feelings, while an ordinary participant will almost never record details of routine activities.

There are many types of participation. The degree of involvement, both with people and in the activities ethnographers observe can vary:

**Figure 27.1** Types of Participation along a Continuum of Involvement  
(Source: Spradley 1980: 58)

<i>Degree of Involvement</i>	<i>Type of Participation</i>
High	Complete Active Moderate
Low	Passive
(No involvement)	Non-participation

In passive participation, the ethnographer is present at the scene of action but does not participate or interact with the people involved. The passive participant is merely a ‘by-stander’ or ‘spectator’. Often, participant observation in public places begins with passive participation. In contrast, the active participant seeks to *do* what other people are doing, not merely to gain acceptance, but to more fully learn the cultural rules for behaviour. It depends on the purpose of the research project which type of participant is desirable or feasible. Complete participation, for example, may not be possible unless you are a member of the group or community being studied. Active participation is often not possible if you want to study the interaction between doctors and patients in a clinic, unless you are a doctor or a patient yourself.

Participation should not be mechanical. Participant observation should not become manipulative in the sense that you participate in a community’s activities only to extract information. Over the years, participant observation has been expanded into a

broader concept of *participatory action research*, where the distinctions between informants and researchers are minimized. In community health research, it is useful to involve the community in the entire research process, such as formulating the methods and instruments. Such methods may yield valuable information that relates immediately to the community's interests, and can spur immediate action or intervention.

## 5 Drawing out Context

Ethnographic research always considers context. Human interaction always takes place in a certain setting. In other words, an ethnographic session always aims to answer the following questions, in relation to your topic of research:

---

	thinking		
WHO is	saying	WHAT to WHOM	and WHY?
	doing		

---

Notice that we differentiate 'thinking', 'saying' and 'doing' because what people *say* they do may not necessarily be the same thing that they actually *do*. A good ethnographer must therefore be a good observer to understand the total context of culture.

*Analyze the following statement: 'Let me help'.*

*Three simple words that will have different meanings in different contexts. When a man tells another man, 'Let me help' it reflects a simple exchange of words that results in either acceptance or a polite refusal of the help being offered. The same situation applies when a woman uses that same statement with another woman. Now, when a man says, 'Let me help' to a woman, it may actually mean: 'Let me do it for you. You can't do it yourself.' Notice that if a woman says: 'Let me help' to a man, again in many cultures, the man will interpret it through his male culture to mean: 'Let me do it for you. You can't do it yourself' even if the woman really was giving a simple offer to help. The man may therefore react with resentment because he assumes the woman thinks he is not capable of doing the task himself. This is the case in some, but not all, cultures. One has to understand the social relations in a particular culture to be able to 'read' the actual message or messages. Think of your own culture and how a sentence can take different meanings when spoken between two men; two women; from a man to a woman and from a woman to a man.*

Gender differences may interact with other differences, such as class or socio-economic status. A good ethnographer tries to observe such exchanges and to understand as many hidden messages as possible, especially in the way they relate to social statuses and roles. This is where ethnography becomes ethnology, as the researcher tries to describe, analyze and understand the different meanings of ideas, words and actions.

In this Module we have concentrated mainly on the advantages of ethnographic techniques. Of course these have some limitations too. The outcome of the use of ethnographic techniques depends a lot on the personal qualities and character of the

ethnographer. Some individuals are keen observers, while others fail to notice or remember many of the details. Some individuals have no difficulties in making contact with others and adapting themselves to new social situations. Every individual has areas of special interest and expertise that affect his or her habits of observation. The theoretical orientation of a researcher also affects the way (s)he sees an event. Fieldworkers need to become aware of their own strengths in observational style: they should practice observing and recording events in order to discover observational biases and to learn to direct their attention to features they might ordinarily tend to neglect. Many ethnographers, for instance, have neglected the role women played in society – focusing mainly on the public domain which is often dominated by men.

The same reservations can be made for ethnographic interviewing. Different interviewers can elicit different answers from the same informants. The social characteristics, the style of the presentation and other qualities of the interviewer have an important effect on the informant. The reliability of the ethnographic interview could be improved by long-term contact between ethnographer and informant, although it should be taken into account that their friendship will definitely colour the information given by the informant. By combining several research methods (triangulation) the information from various sources can be validated and you gain a clearer picture of the community.

Apart from the interviewer-effect on the quality of key-informant responses there are other problems in the interpretation and analysis of verbal data from selected interviews which will be discussed in Module 25.

#### 4 The Ethnographic Record

An ethnographic record consists of field notes, audio or video tape recordings, photographs, artifacts (material objects), and anything else which documents the culture you are studying. Field notes form the core of your ethnographic record. The field notes record your observations, conversations, interpretations, and suggestions for future information to be gathered.

It may not always be appropriate to be taking field notes such as during solemn social events. If one cannot take notes during an event, do so as soon as it is convenient and proper. The notes need not be detailed, but they should contain enough substantial verbatim information to help you recall important information when you write a report. Be sure to distinguish direct quotations (what did people actually say) from your own inferences. In recording observations it is best to describe the events themselves rather than the inferences that the observer derives from them. An observational statement such as: 'The two men were very hostile to each other' is overly general and contains a judgement rather than detailed information on the observed situation.

Learn to summarize the observations. The field notes can be similar to a diary, with concrete, descriptive, and contextual information such as dates, places, names of people and general information about your research site. Your notes should serve as a trigger to release remembered information. These notes can be expanded at the end of each day, together with your analysis and interpretation of the information you have gathered.

Remember that field notes are not just records of interviews. Field notes also include materials you may have copied from other documents such as books and journals. The notes may also include relevant information such as materials from billboards, advertisements on radio or television, information brochures.

A fieldwork journal would contain additional notes, including your experiences, feelings, reservations, additional questions rising out of your fieldwork, and even mistakes. Such a journal is important in helping you to improve your work since introspection is part of the fieldwork experience.

The usefulness of your ethnographic records will depend on how you systematize them. Draw up tables of contents and indexes in order to be able to retrieve information quickly when you need them.

## References

- Hammersley, M. & Atkinson, P.  
1983 *Ethnography: Principles and Practice*. London: Routledge.
- Pelto, P.J. & G.H. Pelto  
1978 *Anthropological Research. The Structure of Inquiry*. Second Edition.  
Cambridge: Cambridge University Press.
- Spradley, J.  
1979 *The Ethnographic Interview*. New York: Harcourt Brace Jovanovich.
- Spradley, J.  
1980 *Participant Observation*. New York: Holt, Rinehart and Winston.





**QUALITATIVE DATA COLLECTION TECHNIQUES II:  
FOCUS GROUP DISCUSSIONS**

# FOCUS GROUP DISCUSSIONS

## Objectives

At the end of the Module, the participants should be able to:

- identify the uses and limitations of focus group discussions (FGDs) as a method of data collection in research;
- formulate a FGD discussion guide on a specific research topic.

## Contents

- 1 Characteristics and Uses of Focus Group Discussions
- 2 Advantages and Disadvantages of Focus Group Discussions
- 3 How to Conduct a Focus Group Discussion

Annex 28.1 Sample Discussion Guide

\* Adapted from Module 10c, Health Systems Research Training Series, Volume 2

## 1 Characteristics and Uses of Focus Group Discussions

Focus group discussions (FGDs) were originally developed in the 1940s by sociologists working with the US military in an effort to assess the effectiveness of propaganda materials intended to boost military morale. Since then, FGDs have been used extensively for research to help to evaluate advertising and marketing strategies. The use of FGDs by anthropologists is fairly recent, and is found mainly in applied fields such as intervention research.

In Module 26, the importance of obtaining emic information on concepts, perceptions, and ideas of the group was stressed. A Focus Group Discussion is an important tool to obtain such information.

FGD-techniques can be used to:

- *Focus research and develop relevant research hypotheses.* FGDs allow you to explore in greater depth the problem to be investigated and its possible causes.  
*A district health officer notices in one village there is a low utilization of pregnant women of the services of the Ante-Natal Clinic (ANC). She cannot understand why this is, since in the neighbouring villages most pregnant women attend the ANC. Several FGDs with village leaders, with women of childbearing age, and with health staff assigned to the village can help the district health officer to identify some of the possible causes of the problem, such as local beliefs and preferences. Such information can be used to help formulate plans for more intensive research for appropriate interventions.*
- *Formulate appropriate questions for more structured surveys.* Designing a good questionnaire requires some preliminary understanding of the local language and concepts.  
*Planners are interested in finding out drug utilization patterns. An FGD can be conducted to find out the most commonly used medicines in the community and the uses (including local names of illnesses) of these medicines. Doing an FGD reduces the number of open-ended questions and allows for the use of appropriate local terms.*
- *Supplement or confirm information on community knowledge, beliefs, attitudes and behaviour already available but that may be incomplete or unclear.*  
*During a survey on birthing practices, it is discovered that there are a few households where the mother self-delivers. You want to get more information on this practice. Holding an FGD with several mothers can help you get information, such as actual experiences with self-delivery and the reasons why some mothers (prefer to) self-deliver.*
- *Develop appropriate messages for health education programmes.*  
*You want to develop an information campaign on the use of oral rehydration solution for infants with diarrhoea. This campaign is supposed to be for rural mothers. An FGD with mothers from several rural areas can help you to explore relevant local*

*concepts that can be integrated into your information materials. An FGD can also be used to pretest draft versions of your materials.*

- *Explore controversial or sensitive topics.* Remember, though, that the willingness to share ideas about sensitive topics will vary according to culture, and according to the issues raised for discussion.

*In a household survey, male informants most frequently said that their wives kept the household money, whereas female informants maintained their husbands kept the money. An FGD with a group of females and a separate one with a group of males may bring forward the complicated patterns and variations of financial responsibility in a household. It could be interesting to have a third session of males and females together to discuss the differences in perception.*

Because FGD participants are usually recruited by convenience, rather than at random, this research method cannot, by itself, be used to test hypotheses or to produce results that are generalizable to the broader population. A focus group discussion is used to explore or to confirm hypotheses, in conjunction with other research methods.

## 2 Advantages and Disadvantages of Focus Group Discussions

FGDs are fairly low-cost and can be conducted rapidly. Because the discussions are conducted with groups, interactions tend to be lively and can produce rich information. Topics that are sensitive or controversial are sometimes better handled through an FGD because participants feel more comfortable or secure about expressing certain views when they are in a group. There is a synergistic effect, where one person will build on what another person has said. Finally, FGDs are flexible, allowing in-depth exploration of different points related to the topic.

On the other hand, focus groups discussions also have some disadvantages. Minority opinions may not always be expressed in an FGD, especially in cultures where confrontations or debates are considered improper. Ideas on deviant or socially-stigmatized behaviour will certainly not emerge unless your FGD participants all belong to a particular group (e.g. sex workers). FGDs are also of limited usefulness for bringing out actual behaviour. Focus Group Discussions will often bring out group norms ('what should be'). FGDs are affected by the usual biases in any research methodology such as the facilitator visibly reacting (favourably or unfavourably) to comments, or the participants giving answers that they think the facilitator wants. As in any group discussion, there may also be dominant participants who are more assertive or aggressive about expressing their views.

Last but not least, FGD results are qualitative in nature and may be difficult to interpret and process.

In recent years, Focus Group Discussions have become very popular with researchers and donors. There is a tendency to think of FGDs as a method that can stand on its own. It is tempting to limit qualitative research to FGDs because they can be conducted so rapidly. However, FGDs are only suitable to explore or to confirm hypotheses and research questions in conjunction with other research methods such as interviews,

surveys and observation. They should never be used as the main or only research method.

### 3 How to Conduct a Focus Group Discussion

The following guidelines may give you the impression that all FGDs need to be formally organized. In reality, there are many opportunities to conduct more informal types of FGDs, such as initiating discussions in ‘natural settings’, such as when people get together to talk at the end of the day.

In intervention research, it is also possible to initiate an FGD as a starting session before you begin health education sessions. This starting session may even be useful in getting people to feel comfortable about expressing their views and ideas.

The guidelines below outline some of the important points you need to consider both in formal, or informal FGDs.

#### A *Preparation*

##### *Preparing question guides for a Focus Group Discussion*

First of all, question lists for FGDs should entail a limited number of questions. Preparing five or six good and relevant questions is generally more than enough for about one and a half hours of discussion with six to ten people. It enables all participants to have their say. If more questions are prepared the facilitator will have to rush through the discussion. One should not forget that in FGDs – contrary to individual interviews – the reaction of one participant can lead to contributions from others: they will remember another example that they wish to share with the others, and so on. In many cases the researcher may want to discuss many more than five or six questions. It can be helpful to list first all the potential questions that could be asked, and then to select the most critical ones.

As with semi-structured interviews it is crucial that the questions – especially in the beginning of the FGD – are open-ended and neutral, giving the participants ample opportunity to give responses that reflect their own situation, revealing what is important for him or her, and not only confirming the researcher’s views. To stimulate participants to reflect on their situation, the facilitator may encourage them to think about the actual situation related to the topic under research. For example, by making them remember their child’s last diarrhoea episode. Literate groups can be asked to answer a few questions on paper to trigger their memories. Giving accurate information on the objectives of the FGD will help the participants be more conscious of the intended focus of the discussion, and it allows the facilitator to remind participants of this focus in cases when their personal stories wander too far from it.

Questions in a FGD follow a logic sequence: moving from more general questions on experiences and ideas, to more specific ones, focusing on the aim of the research. These latter questions are more directed, especially when opinions or suggestions are requested on concrete issues, as, for example, health education material or the most appropriate way to organize mobile immunization clinics.

Closed questions, leading to 'yes' or 'no' answers, are not appropriate to stimulate a lively discussion. 'Why' questions should be avoided as well, because people may be inclined to rationalize their behaviour. 'How' and 'what' questions often give you insight on how people came to act as they did.

It is good to invest some time in requesting comments on the FGD questions from colleagues. Pretesting can be done in the field. After pretesting, the wording and sequence of the questions have to be critically reviewed. If no major changes are made, the data collected in this first FGD can be included for analysis.

### *Recruitment of Participants*

The optimum size for an FGD would be six to twelve participants. If there are only a few participants, the discussion may be limited. If there are too many, it becomes difficult to facilitate the discussion.

Participants should be roughly of the same socio-economic group or have a similar background in relation to the issue under investigation. The age and sexual composition of the group should facilitate free discussion.

If you need to obtain information on a topic from several different categories of informants who are likely to discuss the issue from different perspectives, you should organize a focus group for each major category, e.g. a group for men and a group for women; or a group for older women and a group for younger women. It may be interesting to have an additional discussion in which one group is presented with differing opinions from another group.

Participants should be invited at least one or two days in advance, and the general purpose of the FGD should be explained. You should also explain the purpose of the FGD to town or village officials, especially in areas where group meetings may be viewed suspiciously as political activities.

### *Physical Arrangements*

Communication and interaction during the FGD should be encouraged in every way possible. Arrange the chairs in a circle. You may even decide to hold the discussion sitting on the floor with participants in a circle. Make sure the area is neither too small nor too large, and that there will be minimal disturbances. This may, of course, be difficult in many situations, such as when mothers have to bring in their children.

The FGD should be conducted in a neutral setting, e.g. you cannot have a discussion about the utilization and quality of public health services in a government health center. Always try to minimize other sources of bias, even the presence of health education posters that may force participants to give a 'correct' answer.

### *Participant Incentives*

Remember that an FGD involves time. You should provide incentives for FGD participants such as food and beverages during the FGD.

Whether your incentives are in cash or in kind, be sure that the incentives will not create an obligation on the part of the respondents to give you answers that they think you desire them to give.

### *Preparation of a Discussion Guide*

A written list of topics to be covered should be prepared for each FGD. It can be formulated as a series of open-ended questions. Guides for different groups gathered to discuss the same subject may vary slightly, depending on their knowledge or attitudes and how the subject can first be explored with them. Also prepare other materials such as blackboards, poster papers and pens and discussion aids. An example of a focus group discussion guide is provided in Annex 28.1. In this FGD about medicines a sorting game is included in which the participants are requested to sort actual samples of different drugs.

### ***B Conducting the Session***

One of the members of the research team should act as facilitator or moderator for the focus group while another member should serve as ‘recorder’.

#### *Functions of the Facilitator/Moderator*

The facilitator or moderator should *not* act as an expert on the topic. His or her role is to stimulate and support discussion.

The first task of the facilitator is to introduce the session: introduce both yourself as facilitator and the recorder. Introduce the participants by name or ask them to introduce themselves. Put the participants at ease and explain the purpose of the FGD, the kind of information needed, and how the information will be useful to the community.

A second task for the moderator is to encourage discussion. Be enthusiastic, lively, and humorous and show your interest in the group’s ideas. Formulate questions and encourage as many participants as possible to express their views. Avoid eye contact with a dominant participant, or gently explain that you need to hear from other discussants. Encourage the more passive participants, calling them by name and asking for their views.

Remind participants that there are no ‘right’ or ‘wrong’ answers. React neutrally to both verbal and non-verbal responses. Avoid a question-and-answer session and do not settle for a simple ‘yes’ or ‘no’ answer. Probe for the reasons behind these ‘yes’ or ‘no’ answers.

To build rapport and empathize is an important function of the facilitator. It is always good to have name tags for FGD participants. This allows everyone to relate to each other, and for the facilitator to relate to the participants. Address the participants by their preferred names (and titles, in some cases).

Observe non-verbal communication. Ask yourself: ‘What are they saying? What does it mean to them?’ Be aware of your own tone of voice, facial expressions, body language, and those of the participants. Be sensitive to signs that participants are getting bored, restless, or uneasy.

When you are asked for your ideas or views by a respondent, remember that you are not there to do a health education workshop. Direct the questions back to the group by saying: ‘What do you think?’ ‘What would you do?’ But remember to set aside time, if necessary, after the session to give participants the information they have asked for. Do not try to comment on everything that is being said. There will be times when all the

participants become silent. Wait a little and see what happens, rather than forcing them to say something.

It is important to systematize the discussion from time to time and reorientate the discussion when it goes off the track. Try to keep discussions focused. Systematize the discussion by linking or referring ideas and concepts, e.g. by saying: 'Remember what Mrs. X said earlier about diarrhoea, how does that relate to Mrs. Y's experience?' or 'Mr. X, is your situation similar or different from that of Mr. Y?'

Listen carefully and move the discussion from topic to topic. Subtly control the time allocated to various topics so as to maintain interest. If participants spontaneously jump from one topic to the other, let the discussion continue for a while because useful additional information may surface and then summarize the points brought up and reorientate the discussion.

Take time at the end of the meeting to summarize, check for agreement or disagreement, and thank the participants. Summarize the main issues brought up and check about the group's general feelings about these main points. Let them know that their ideas have been a valuable contribution. Listen for additional comments made after the meeting has been closed.

#### *Functions of the Recorder*

The recorder documents the content of the discussion as well as the processes and interactions during the FGD. Important points to be recorded include:

- date, time, and place;
- names and characteristics (sex, age, occupation) of participants;
- general description of the group dynamics (level of participation, presence of a dominant participant, level of interest);
- opinions of participants, recorded as much as possible in their own words, especially for key statements;
- emotional aspects (e.g. reluctance, strong feelings attached to certain opinions); and
- vocabulary used, particularly in FGDs that are intended to assist in developing questionnaires or health education materials.

While a tape recorder is highly recommended, remember that taping is only a way of assisting in capturing the information. Recordings help to clarify certain points or terms used during the discussion. The human recorder's notes should be seen as more important than the tape recorder.

A supplementary role for the recorder could be to assist the facilitator (if necessary) by drawing his or her attention to:

- missed comments from participants; and
- missed topics (the recorder should have a copy of the discussion guide during the FGD).

If necessary, the recorder could also help the facilitator to resolve conflict situations.



### *C Number and Duration of Sessions*

The number of focus group sessions to be conducted depends upon project needs, resources, and whether new information is still coming from the sessions; that is, whether contrasting views from various groups in the community are still emerging. Plan to conduct at least two different FGDS for each sub-group (for example, two for males and two for females). This allows for comparison of the gathered information.

A focus group session typically lasts up to an hour and a half. Generally the first session with a particular type of group is longer than the following ones because all of the information is new. Thereafter, if it becomes clear that all the groups have the same opinion on particular topics, the facilitator may be able to move the discussion along more quickly to other topics that still elicit new points of view.

### References

- Krueger, R.A.  
1988 *Focusgroups. A practical guide for applied research.* Newbury Park: Sage Publications.
- Merton, R.K., M. Fiske & P.L. Kendall  
1990 *The Focused Interview.* Second edition. New York: The Free Press.
- Morgan D.L.  
1997 *Focus groups as qualitative research.* (Second Edition) London: Sage.
- Stewart, D.W. & P.N. Shamdasani  
1990 *Focus Groups: Theory and Practice.* London: Sage.



**DESIGN OF INTERVIEW SCHEDULES  
AND QUESTIONNAIRES**

# DESIGN OF INTERVIEW SCHEDULES AND QUESTIONNAIRES

## Objectives

At the end of the Module, the participants should be able to:

- understand the various stages in questionnaire design;
- demonstrate appropriate techniques for wording different types of questions;
- demonstrate appropriate techniques for formatting questionnaires to ensure maximum quality of responses.

## Contents

- 1 Introduction
- 2 Types of Questions
- 3 Steps in Designing a Questionnaire

Annex 29.1 Maternal Record

Annex 29.2 Example of a Questionnaire

\* Adapted from Module 10b, Health Systems Research Training Series, Volume 2

## 1 Introduction

Interviews and self-administered questionnaires are probably the most commonly used research techniques. These instruments are structured in the sense that there is a fixed set of questions that have to be asked. Once the decision has been made to use these techniques, the following questions should be considered before designing our tools:

- What exactly do we want to know, according to the objectives, hypotheses and variables we have identified?
- Is questioning the right technique to obtain all answers, or do we need additional techniques, such as observation or analysis of records?
- Are there previous studies that have been done, with questionnaires that can be adapted? There is no sense reinventing the wheel. At the same time, be aware of cross-cultural differences that may make it difficult or even impossible to adapt some of the questionnaires used in another culture.
- Whom will we ask questions and what techniques will we use? Do we understand the topic sufficiently to design a questionnaire, or do we need some loosely structured interviews with key informants or an FGD first to orientate ourselves?
- What is the level of literacy among the informants? If the level of literacy is low or if our informants are completely illiterate, the use of self-administered questionnaires is not possible. There are other options remain, however. See Annex 29.1 for an example of a Maternal Record for use by non-literate traditional birth attendants.
- How large is the sample that will be interviewed? Studies with many respondents often use shorter, highly structured questionnaires, whereas smaller studies allow more flexibility and may use questionnaires with a number of open-ended questions. Always maintain a balance between a scientifically acceptable sample size and your available logistical resources for data collection and analysis.

## 2 Types of Questions

Before examining the steps in designing a questionnaire, we need to review the types of questions used in questionnaires. Depending on how questions are asked and recorded we can distinguish between *open-ended* and *closed* questions.

### *Open-Ended Questions*

Such questions are useful to obtain information on facts with which the researcher is not very familiar: opinions, attitudes, and suggestions of informants or sensitive issues.

*‘What do you think are the reasons for a high drop-out rate of village health committee members?’*

### *Closed Questions*

Closed questions offer a list of possible options or answers from which the respondents must choose. When designing closed questions you should try to:

- offer a list of options that are exhaustive and mutually exclusive; and
- keep the number of options as few as possible.

Closed questions are useful if the range of possible responses is known.

*‘What is your marital status?’*

- |   |                            |                       |
|---|----------------------------|-----------------------|
| 1 | Single                     | <input type="radio"/> |
| 2 | Married/living together    | <input type="radio"/> |
| 3 | Separated/divorced/widowed | <input type="radio"/> |

*‘Have you ever gone to the local village health worker for treatment?’*

- |   |     |                       |
|---|-----|-----------------------|
| 1 | Yes | <input type="radio"/> |
| 2 | No  | <input type="radio"/> |

Closed questions may also be used if you are only interested in certain aspects of an issue and do not want to waste the time of the respondent and interviewer by obtaining more information than one needs.

*A researcher who is only interested in the protein content of a family diet may ask:*

*‘Did you eat any of the following foods yesterday?’*

*(circle ‘yes’ or ‘no’ for each set of items)*

- |                     |     |    |
|---------------------|-----|----|
| Peas, bean, lentils | Yes | No |
| Fish or meat        | Yes | No |
| Eggs                | Yes | No |
| Milk or cheese      | Yes | No |

Closed questions may be used as well to get the respondents to express their opinions by choosing rating points on a scale.

*‘How useful would you say the activities of the Village Health Committee have been in the development of this village?’*

- |   |                   |                       |
|---|-------------------|-----------------------|
| 1 | Extremely useful  | <input type="radio"/> |
| 2 | Very useful       | <input type="radio"/> |
| 3 | Useful            | <input type="radio"/> |
| 4 | Not very useful   | <input type="radio"/> |
| 5 | Not useful at all | <input type="radio"/> |

Be careful when using attitudes scales. Such scales are advisable only in face-to-face interviews with literates if the various options for each answer are provided for the respondents on a card they can look at while making their choice. If the researcher only reads the options, the respondents might not consider all options equally and the scale will not accurately measure the attitudes. Some researchers feel that distinctions between ‘extremely’ and ‘very’ may be artificial or subjective.

**Table 29.1** Advantages and Disadvantages of Open-Ended and Closed Questions and Conditions for their Optimal Use

<i>Open-Ended Questions</i>	<i>Closed Questions</i>
<i>Advantages</i>	<i>Advantages</i>
Issues not previously thought of when planning the study may be explored, thus providing valuable new insights into the problem.	Answers can be recorded quickly. Analysis is easy.
Information provided spontaneously is likely to be more valid than answers suggested in options from which the informant must choose.	
Information provided in the respondent's own words may be useful as examples or illustrations that add interest to the final report.	
<i>Disadvantages</i>	<i>Disadvantages</i>
Skilled interviewers are needed to get the discussion started and focused on relevant issues and to record all important information.	Closed questions are less suitable for face-to-face interviews with non-literates.
Analysis is time-consuming and requires experience.	Respondents may choose options they would not have thought of themselves (leading questions bias). Important information may be missed if it is not asked.
	The respondent and interviewer may lose interest after a number of closed questions.
<i>Suggestions</i>	<i>Suggestions</i>
Thoroughly train and supervise the interviewers.	Use closed questions only on issues that are simple.
Prepare a list of further questions to keep at hand to use to 'probe' for answer(s) in a systematic way.	Pretest closed questions first as open-ended questions to see if your categories cover all possibilities.
Pretest open-ended questions and, if possible, pre-categorize the most common responses, leaving enough space for other answers.	Use closed questions in combination with open-ended questions.

In practice, a questionnaire usually has a combination of open-ended and closed questions, arranged in such a way that the discussion flows as naturally as possible.

In a face-to-face interview, questions are often asked as open-ended questions, but to facilitate recording and analysis, possible answers are to a large extent pre-categorized.

*'How did you become a member of the Village Health Committee?'*

- |   |                                       |                       |
|---|---------------------------------------|-----------------------|
| 1 | <i>Volunteered</i>                    | <input type="radio"/> |
| 2 | <i>Elected at a community meeting</i> | <input type="radio"/> |
| 3 | <i>Nominated by community leaders</i> | <input type="radio"/> |
| 4 | <i>Nominated by the health staff</i>  | <input type="radio"/> |
| 5 | <i>Other (specify)</i>                | <input type="radio"/> |

-----  
 -----

The interview guide or questionnaire should indicate whether the informant can give more than one answer to a question. For open-ended questions, more than one answer is usually allowed. The interviewers will have to be trained to wait for additional answers. They should also be instructed not merely to tick the options mentioned, but to record any additional information a respondent may provide.

*Note:* Sometimes it is useful, especially in small-scale studies, to use pictures or drawings when asking certain questions. A sample of such pictures used in one interview schedule is provided in Annex 29.1.

### 3 Steps in Designing a Questionnaire

Designing a good questionnaire always takes several drafts, corresponding to different steps in the design process. With each draft, try to concentrate on one aspect of the questionnaire, for example:

- Draft 1: Content
- Draft 2: Formulation and sequence of questions
- Draft 3: Format of the questionnaire
- Draft 4: Translation (where needed)

As with any research tool, a pretest should always be conducted. In this Module, we will explain the first four steps while pretesting will be discussed in Module 22.

#### *Step 1 Content*

Take your objectives, and research questions and problem analysis diagram, as your starting point. Decide what questions will be needed to measure or to define your variables and reach your objectives. When developing the questionnaire, you should reconsider the variables you have chosen, and, if necessary, add, drop or change some. You may even change some of your objectives at this stage if they seem impractical. Consider the best way to ask different types of questions:

- factual or subjective?
- knowledge or perception?
- attitudes?
- behaviour?



## Step 2 Formulating Questions

Formulate one or more questions that will provide the information needed for each variable. Take care that questions are specific and precise enough that different respondents do not interpret them differently.

*A question such as: ‘Where do community members usually seek treatment when they are sick?’ cannot be asked in such a general way because each respondent may have something different in mind when answering the question:*

- *One informant may think of measles with complications and say he/she goes to the hospital while another respondent is thinking of cough and says he goes to the private pharmacy.*
- *Even if both think of the same disease, they may have different degrees of illness severity in mind and thus answer differently.*
- *In all cases, self-care may be overlooked.*

The question, therefore, as a rule, has to be broken up into different parts and made so specific that all informants focus on the same thing.

*While studying health seeking behaviour one could:*

- *concentrate on an acute illness case that has occurred in the family over the past fortnight and ask what has been done to treat it from the onset; or*
- *concentrate on a number of diseases and ask whether they have occurred in the family over the past X months. Chronic or serious diseases have a longer recall period than minor ailments. Then you can ask what has been done from onset of the named diseases or illnesses.*

Another important thing is to check whether each question measures one thing at a time.

*The question: ‘How large an interval would you and your husband prefer between two successive births?’ would better be divided into two questions because husband and wife may have different opinions on the preferred birth interval.*

Keep questions brief and use simple, everyday language. Use words that the respondent can understand. A long question can be confusing, especially if it is read to the respondent. Generally, if the question goes beyond 20 words, it may mean you are asking too many things at the same time. On the other hand, the question should not be so brief as to be vague.

Avoid *leading questions*. A question is leading if it suggests a certain answer.

*The question: ‘Do you agree that the district health team should visit each health centre monthly?’ hardly leaves room for ‘no’ or for other options. A better question would be: ‘Do you think that district health teams should visit each health centre? If yes, how often?’*

Questions about opinions are most prone to bias so the safest thing to do is to present all options.

*Not acceptable: 'Don't you agree that...'*

*Weak: 'Do you agree that...'*

*Better: 'Do you agree or disagree that...'*

Sometimes, a question is leading because it presupposes a certain condition.

*'What action did you take when your child had diarrhoea the last time?' presupposes the child has had diarrhoea. A better set of questions would be: 'Has your child had diarrhoea? If yes, when was the last time?' 'Did you do anything to treat it? If yes, what?'*

Formulate control questions to *cross-check* responses on 'difficult' questions, i.e. sensitive questions or questions for which it is difficult to get a precise answer.

Avoid words with double or vaguely defined meanings and emotionally laden words. Concepts such as nasty (health staff), lazy (patients), or unhealthy (food), for example, should be omitted.

Avoid questions that are threatening or that may make the respondent feel ignorant. Asking too many questions that directly probe into the respondent's knowledge can be threatening. People may perceive the questionnaire as an exam. Rephrase some questions as probing into their opinions or views: instead of asking 'Do you know of . . .', you can ask, 'What do you think of . . .'

Be realistic about the kind of information that can be obtained. Recognize that certain types of information may not be easy to obtain. One major problem is that of *recall*. Always check if you yourself can answer some of the questions you ask, e.g.: 'How many times did you have cough and colds in the last year?' On the other hand, while you may not remember what you ate three days ago, many people living in poverty will remember since there may be very little variation in their diet. The problem of recall loss is a major cause of response errors. Try to reduce these problems by using a realistic recall period (e.g., not more than one month for less serious ailments).

Also explore the possibilities of using other tools such as *tracer lists*. Tracer lists can be drawn up for common illnesses, for illness symptoms, food items, medicines (see the example of a questionnaire in Annex 29.2). Such lists are developed out of preliminary research, such as inquiring about what the most common illnesses in the community might be. This way, you have a short list of possible answers that can be incorporated into your questionnaire.

In some cases, you may have to complement the survey with other tools such as *calendars or diaries* that you can leave with the respondent. Always remember that there are alternative research methods, such as ethnographic interviews or focus group discussions, that may have to be used for topics that are too sensitive or controversial.

### Step 3 Sequencing of Questions

The sequence of questions must be logical for the respondent and allow as much as possible for a 'natural' discussion. In a survey on maternal and child health, you can arrange the questions to go from ante-natal care, to the birth delivery and on to post-natal care.

At the beginning of the interview, keep questions concerning contextual variables (e.g. age, religion, education, marital status, or occupation) to a minimum. Some respondents may be reluctant to provide personal information early in the interview, even if confidentiality is assured, so save such questions for the end.

Start with interesting but non-controversial questions, preferably open-ended, that are directly related to the subject of the study. This type of beginning should help to raise the informant's interest and lessen suspicions concerning the purpose of the interview, for example that it will be used to provide information to use in levying taxes.

Pose more sensitive questions as late as possible in the interview. Examples are questions pertaining to income, political matters, sexual behaviour, or diseases with stigma attached to them.

You may want to ask questions about behaviour or practices before questions about attitudes. The reason here is that if you first ask about attitudes, the respondent may orientate his/her answers about practices in such a way as to conform with what (s)he may perceive to be 'correct' norms. Attitudinal questions are difficult to ask; if you bring them in at the wrong time, they may also affect answers to questions about the respondent's behaviour.

*If you first ask opinion questions like 'Do you think paying for sex is right or wrong?' the respondent may be unwilling to admit to patronizing sex workers later in the survey.*

Make the questionnaire as short as possible. Conduct the interview in two parts if the nature of the topic requires a long questionnaire, i.e. more than one hour to complete.

### Step 4 Formatting the Questionnaire

When you finalize your questionnaire, be sure that the questionnaire's length is reasonable. After going through several drafts, there is a tendency for the questionnaire to expand to an unreasonable length. Review the questions and check if this can still be used in the field. Do you have all the information needed? Will you be able to process and analyze the data?

It is often useful to draw up dummy tables, listing different variables that you want to analyze and correlate. *Dummy tables* are tables that are not yet filled in with data (see Module 26). These help you to evaluate the questionnaire's usefulness.

Each questionnaire should have a heading and space to insert the number, date, and location of the interview, and, if required, the name of the informant. You may add the name of the interviewer to facilitate quality control.

Very clear instructions should be given to the interviewers or to the respondents for *self-administered questionnaires*. This includes definitions of particular terms that may

be interpreted in different ways, for example: what do you mean by ‘sexual intercourse’? An explanation of the research project should appear at the beginning of the questionnaire, together with assurances of confidentiality.

Points to consider in the formatting of questionnaires are the following:

- Make sure to group the same type of questions together. In KAPB studies, it helps to group questions according to ‘knowledge’, ‘attitudes’ and ‘practices’. For other questionnaires, you can group the questions by topic.
- Sufficient space should be provided for answers to open-ended questions;
- Boxes for pre-categorized answers are placed in a consistent manner, e.g. on the right half of the page.
- If you use a computer, the right margin of the page should be reserved for boxes or columns intended for computer codes. It is best to consult with your computer programmers or statisticians on formatting.

A good example of a questionnaire is presented in Annex 29.2.

Finally, remember that the questionnaire’s presentation can have an effect on the respondent. Invest a little for good printing and good paper. A respondent will not take you seriously if your questionnaire is hardly readable because it has been poorly produced.

### *Step 5 Translation*

If interviews will be conducted in one or more local languages, the questionnaire has to be translated to standardize the way questions will be asked. Avoid the use of on-the-spot interpreters since this tends to produce more errors.

After having it translated you should have it retranslated into the original language. The person doing this translation back to the original language should be someone who was not involved in the first translation. You can then compare the two versions for differences and make a decision concerning the final phrasing of difficult concepts.

When translating questions, be sure to examine for three things: linguistic equivalence; cultural equivalence, and cultural appropriateness.

#### *A Linguistic Equivalency*

This applies both to grammar and syntax. Even slight changes in wording can change the original meaning. In Filipino, for example, the word *sinat* is often literally translated as ‘slight fever’ but this is inaccurate because *sinat* simply means a subjective evaluation of slightly elevated body temperature that is *not* necessarily considered as fever (e.g. *sinat* that comes after strenuous physical activity).

#### *B Conceptual Equivalency*

Even if a translation carries linguistic equivalency, it may still lack conceptual equivalency. For example, ‘dehydration’ may be too abstract a term in many places. You may therefore need to use actual physical signs of dehydration (such as very little urination), rather than the term ‘dehydration’ itself.

### *C Cultural Appropriateness*

This overlaps with conceptual equivalency. When you ask a mother if her child is ‘thin’ she may give an answer based on the norms in her village. If all the children are under-nourished, ‘thinness’ may not be recognizable.

Research on sex or other sensitive topics will also need to consider what terms are acceptable or unacceptable in the community.

### *Step 6 Preparations for the Field*

Pretest drafts of your questionnaire in an actual field situation with small groups of respondents. The main purpose of the pretest is to ensure that respondents understand the questions and answer them usefully. Thus, in each pretest interview, the respondent should go through debriefing, where he or she is asked about the questions, and the interview process. Several pretests may be necessary.

Another objective of pretesting is to assess cost factors. The pretest gives you the opportunity to assess how long it takes to administer each questionnaire, and how many respondents can be covered in one day, by the number of interviewers you have.

Preferably, you should have recruited interviewers even in the planning stage so they can participate in questionnaire formulation. When choosing interviewers, you should keep in mind demographic variables (such as age, sex, ethnicity, educational level) that may be important in the survey process. Usually, interviewers should have similar backgrounds with that of respondents. Also screen interviewers for certain attitudes and skills:

#### *Positive Attitudes in an Interviewer:*

- willingness to listen
- openness toward other opinions
- non-judgemental
- prepared to work at irregular times
- prepared to travel
- ability to create rapport and establish confidence

#### *Positive Skills:*

- previous interviewing experience
- acceptable level of literacy and numeracy
- clear handwriting
- able to follow instructions and to think of alternatives if there are problems in the survey

Interviewers should be trained before going to the field. They should be familiar with the questions to be asked, as well as the intent and meaning of each of the questions. They should be briefed on the sampling method, and contingencies (e.g., calling back at a household, or substituting another respondent).

Provisions should also be made for field supervision and editing. This means checking completed interview schedules for errors, omissions and discrepancies soon after interviewing is completed. Be sure to make allowance in your schedules for field-work to cover data gaps, which may require revisits to the research sites.

## References

Aday, L.A.

- 1989 *Designing and Conducting Health Surveys*. San Francisco: Jossey-Bass Publishers.

Kroeger, A.









- 1988 'Introduction to the Methodology of Household Surveys.' In: *Training Modules for Household Surveys on Health and Nutrition*. Geneva: World Health Organization, Epidemiological and Statistical Methodology Unit.

Peeters, R. & A. Kroeger

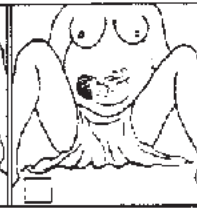
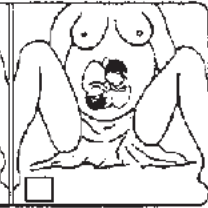
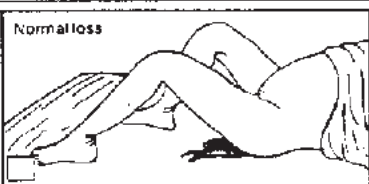
- 1988 'Interviewers: Selection and Training.' In: *Training Modules for Household Surveys on Health and Nutrition*. Geneva: World Health Organization, Epidemiological and Statistical Methodology Unit.

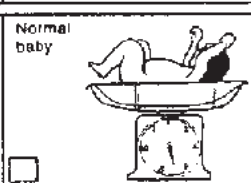
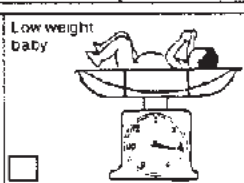
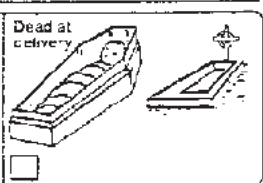
### Annex 29.1 Maternal Record\*

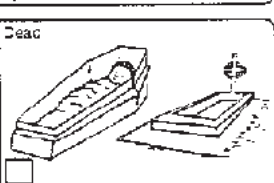
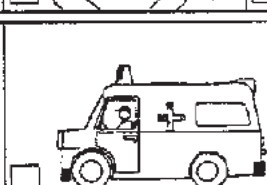
Name of mother \_\_\_\_\_ Name of TBA \_\_\_\_\_  
 Age of mother \_\_\_\_\_ Date of delivery \_\_\_\_\_  
 Parity \_\_\_\_\_ Number \_\_\_\_\_

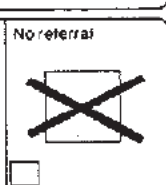
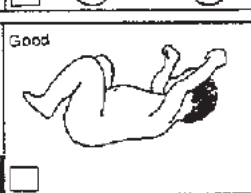
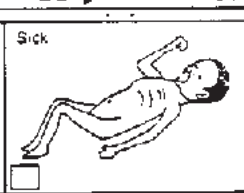
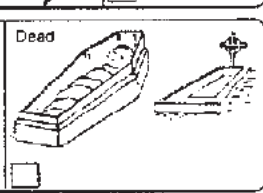
<p><b>1</b> Presentation of baby</p>	 <input type="checkbox"/>	 <input type="checkbox"/>	 <input type="checkbox"/>	 <input type="checkbox"/>
<p><b>2</b> Blood loss of mother during and after delivery</p>	<p>Normal loss</p>  <input type="checkbox"/>	<p>Abnormal loss</p>  <input type="checkbox"/>		
<p><b>3</b> Condition of baby at delivery</p>	<p>Normal baby</p>  <input type="checkbox"/>	<p>Low weight baby</p>  <input type="checkbox"/>	<p>Dead at delivery</p>  <input type="checkbox"/>	
<p><b>4</b> Condition of mother after delivery</p>	<p>Good</p>  <input type="checkbox"/>	<p>Sick</p>  <input type="checkbox"/>	<p>Dead</p>  <input type="checkbox"/>	
<p><b>5</b> Referral to hospital</p>	 <input type="checkbox"/>	 <input type="checkbox"/>	<p>No referral</p>  <input type="checkbox"/>	
<p><b>6</b> Condition of baby at one week</p>	<p>Good</p>  <input type="checkbox"/>	<p>Sick</p>  <input type="checkbox"/>	<p>Dead</p>  <input type="checkbox"/>	

\* This questionnaire, which was made for use by non-literate Traditional Birth Attendants, was provided by Dr. Peter Lamptey.

**Annex 29.2 Example of a Questionnaire \***

INJECTION PRACTICE RESEARCH (Household survey) Indonesia		Form A:  No.:   □□□
Date of interview           : .....	Date of check               : .....	
Name of interviewer       : .....	Name of Team Leader                       : .....	
Signature:                   : .....	Signature                   : .....	
<b>1.</b> Subdistrict               : .....		<input type="checkbox"/>
<b>2.</b> Village                   : .....		<input type="checkbox"/>
<b>3.</b> RT/RW                   : .....		<input type="checkbox"/>
<b>4.</b> Name head of household : .....		
<b>5.</b> Employment of household head:		<input type="checkbox"/>
1. Housewife / not employed		
2. Farming / fishing		
3. Paid labourer in factory of farm		
4. Business or self-employment		
5. Government or military		
6. Private firm		
7. Pension		
8. Others, describe .....		
<b>6.</b> Ethnic group: .....		<input type="checkbox"/>
<b>7.</b> Religion                 1. Islam                         4. Hinduism		<input type="checkbox"/>
2. Christian                    5. Others		
3. Buddhist		
Respondent:		
<b>8.</b> Name of respondent    : .....		
<b>9.</b> Relationship with HHH: .....		
<b>10.</b> Sex                     : 1 male                         2. female		<input type="checkbox"/>
<b>11.</b> Age                    : .....		<input type="checkbox"/>
<b>12.</b> Educational level of respondent:		<input type="checkbox"/>
1. To young for schooling		
2. No schooling or an-alphabetic		
3. Not finished primary school		
4. Finished primary school		
5. Finished secondary school		
6. Finished highschool		
7. Finished university		

\* This questionnaire, designed to research the prevalence of injection use at the household level in two districts in Indonesia, was prepared by Dr. Rudy Salan and his collaborators.



<b>13. Number of members in household:</b>							
Name:	Age	Sex	Education	Status in household			
1.					□□□□		
2.					□□□□		
3.					□□□□		
4.					□□□□		
5.					□□□□		
6.					□□□□		
7.					□□□□		
8.					□□□□		
9.					□□□□		
10.					□□□□		
11.					□□□□		
12.					□□□□		
<b>14. In the last 2 weeks was someone in your family ill:</b>							
1. Yes							
2. No, proceed to question 22					□		
<b>15. If yes, which household member? (Please note down only the consecutive number of question 13)</b>							
a. ....					□□		
b. ....					□□		
c. ....					□□		
d. ....					□□		
e. ....					□□		
<b>Questions</b>			<b># of HH member (according to question 15)</b>				
			a.	b.	c.	d.	e.
<b>16. What kind of illness did you have?</b>							
1. Fever							
2. Cough / cold							
3. Abdominal pains / diarrhea							

Questions	# of HH member (according to question 15)					
	a.	b.	c.	d.	e.	
<b>4. Weakness / muscle pain</b>						□□□□□
<b>5. Skin disease</b>						□□□□□
<b>6. Others (describe:</b>						□□□□□
<b>17.</b> Where did you go for help?						
1. Hospital						□□□□□
2. Health centre						□□□□□
3. Sub health centres						□□□□□
4. Integrated health post						□□□□□
5. Outpatient clinic						□□□□□
6. Doctor (private pract.)						□□□□□
7. Nurse (private practice)						□□□□□
8. Midwife (private pract.)						□□□□□
9. Health cadres						□□□□□
10. Healers						□□□□□
11. No help requested						□□□□□
<b>18.</b> Was the patient given:						
1. Injection						□□□□□
2. Only oral medication						
3. Combination of both						
<b>19.</b> Where did you get this injection?						
1. Hospital.						□□□□□
2. Health centre						□□□□□
3. Sub health centre						□□□□□
4. Integr. health post						□□□□□
5. Outpatient clinic						□□□□□
6. Doctor (private pract.)						□□□□□
7. Nurse (private pract.)						□□□□□

Questions	# of HH member (according to question 15)					
	a.	b.	c.	d.	e.	
<b>19.</b> Where did you get this injection?						
8. Midwife (private pract.)						□□□□□
9. Health cadre						□□□□□
10. Healer						□□□□□
<b>20.</b> Is this injection given on the request of the patient or the family?						
1. Yes						□□□□□
2. No						
<b>21.</b> Why does the patient or the family requested to be injected?						
1. Works faster						□□□□□
2. cheaper						□□□□□
3. It is customary						□□□□□
4. Often forget to take medicine						□□□□□
5. Others						□□□□□
<b>22.</b> According to you, which illnesses should be given injections?						
1. Fever						□
2. Cough / cold						□
3. Abdominal pains / diarrhea						□
4. Weakness / muscle pains						□
5. Skin disease						□
6. Don't know						□
7. Others, describe:						□
<b>23.</b> What are your expectations after you are given an injection?						
.....						
.....						



**MODULE 30**

**SAMPLING**

# SAMPLING

## Objectives

At the end of this session, the participants should be able to:

- identify and describe common methods of sampling used in qualitative and quantitative research;
- discuss issues related to the choice of sampling method;
- list the factors to consider when deciding on sample size;
- decide on the sampling method most appropriate for the research design being developed.

## Contents

- 1 Introduction
- 2 Sampling Methods
  - A *Purposeful Sampling for Qualitative Studies*
  - B *Probability Sampling for Quantitative Studies*
- 3 Bias in Sampling
- 4 Ethical Considerations
- 5 Sample Size

## 1 Introduction

What is sampling?

---

SAMPLING involves the selection of a number of study units from a defined study population.

---

When selecting a sample, a researcher first needs to decide which population he/she intends to study. This depends on the research objectives and questions. Sampling strategies need to be defined as one can rarely cover each and every person in the selected population.

In qualitative studies they aim to identify *information rich* cases in a purposeful manner. Information rich cases are those from which one can learn a great deal about issues of central importance to the purpose of the research, thus the term *purposeful sampling*. For example, when one wants to understand how women who are infertile cope, one will want to conduct in-depth interviews with women who experience infertility.

Quantitative sampling typically depends on large samples selected randomly. A truly random and statistically representative sample allows for generalization from the sample to the larger population. The purpose of such sampling methods is not to gain in-depth understanding of an issue, but to be able to generalize findings.

### *Selection of Study Sites*

This chapter deals with the sampling of households or individuals as study units. Before selecting households or individuals, a researcher needs to identify relevant study sites or in other terms, the population from which a sample is to be drawn.

The selection of study sites depends both on the objectives of the study and on pragmatic factors (such as the distance to be traveled, and contact which can facilitate entry into the community).

The research objectives provide the researcher with criteria to select study sites. For example, a study on perceptions and practices regarding childhood malaria is best done in communities with a high incidence of malaria.

The next step is to consider the heterogeneity of the potential study population – i.e. households with children who live in malaria-endemic areas. If ethnicity is an important factor, the researcher may want to select communities with different ethnic profiles. Or, alternatively, to allow for profound ethnographic study, the researcher may decide to focus on malaria perceptions and practices in one community with people who belong to the largest ethnic group of the country or region.

In the preparatory phase of a study, researchers should identify various research sites that are congruent with the research objectives. On site visits, they should discuss the study's objectives with health programme managers, community leaders and representatives of other relevant institutions. Final selection of study sites is based not only on the research site characteristics, but also on the willingness of health workers and community leaders to participate in and facilitate the study.

When the research sites have been selected, the researchers need to decide on the sampling method to be used to select individuals and/or households in the community. Below is a discussion on the most commonly used qualitative and quantitative sampling methods.

## 2 Sampling Methods

### A *Purposeful Sampling for Qualitative Studies*

There are several strategies for purposeful sampling of information rich cases. The methods most commonly used by anthropologists in qualitative studies are given below, including the purpose for which the method is especially useful and its disadvantages.

#### 1 *Convenience Sampling*

---

CONVENIENCE SAMPLING is a method in which for convenience sake the study units that happen to be available at the time of data collection are selected in the sample.

---

Many clinic-based studies use convenience samples.

*A researcher wants to study the attitudes of villagers toward family-planning services provided by the MCH clinic. He decides to interview all adult patients who visit the outpatient clinic during one particular day. This is more convenient than taking a random sample of people in the village and it gives a useful first impression.*

A drawback of convenience sampling is that the sample may be quite biased. Some people may be overselected, others underselected or missed all together. In the above example, the people missed are those who perhaps because of bad experiences do not come to the clinic anymore. To gain insight on the views of non-users of the clinic one would need to select informants in the community rather than at the clinic.

#### 2 *Maximum Variation Sampling*

This sampling method aims to select study units which represent a wide range of variation in dimensions of interest. For example, the researcher may be interested in family planning practice and assume that religion is an important background variable. The researcher is afraid to miss the Catholics, who are a minority in the area. She or he, therefore, decides to include in the study 15 women from each of the different religious groups (Hindus, Muslims, Protestants, and Catholics) and to extend the study over 3 or 4 days to obtain the desired sample. In the same case, other important dimensions are age, marital status and number of children. Within each ethnic group the researcher



can decide to interview at least five unmarried women, five young married women with not more than one child, and five women who have been married for at least three years and have two or more children.

Maximum variation can also be used as a strategy to select communities in which to do research. In the above example, this would imply that the researcher selects in a Hindu, Muslim, Protestant and Catholic community. Maximum variation sampling is also often used when deciding on which groups to involve in focus group discussions. Recall, the informants participating in each FGD should be relatively homogenous as far as key background variables for the study are concerned.

Using a maximum variation sampling strategy allows one to identify shared experiences in the sample. Important shared patterns derived from a heterogeneous study population are more significant than those derived from a more homogenous group of respondents. For example, in a study on self-care practices in childhood disorders among urban poor of different ethnic backgrounds in Manila a researcher found that a few herbal remedies, such as ginger for a sore throat, and guave for diarrhoea, are used commonly by all respondents. She posed that these are practices which are indigenous in various regions of The Philippines. These herbal practices are reinforced in the heterogeneous ethnic communities in the cities. More culture-specific practices tend to be 'forgotten' in urban life.

### 3 *Snowball Sampling*

Snowball sampling is perhaps the most common sampling method used in qualitative studies. The researcher starts identifying some (at least two) individuals who are relevant to the study, for example, women with preschool children in a study on perceptions of the quality of the vaccination programme; and then asking them to locate other useful informants, i.e. other mothers of preschool children. The advantage of this method is that one informant refers the researcher to another and that the researcher therefore has a good introduction for the next interview. A disadvantage is that the variation in the sample may be limited because it consists of informants who belong to the networks of the index cases. Therefore, it is important to have at least two different entrances in the community.

### 4 *Sampling Contrasting Cases*

In comparative studies sampling will involve two or more population groups with distinct characteristics. This sampling method is useful in comparative studies which aim to explain problems by establishing which factors are associated with it or cause it. For example, the study may intend to determine the reasons for not using family planning services by comparing the group of reproductive age women who do and who do not use the services. Or, in a study on the use of oral rehydration therapy (ORT) to prevent childhood death in diarrhoea cases, one can sample women who do use ORT and those who do not, and compare these two groups in the analysis.

Contrast sampling can also be used in selecting research sites. For example, when evaluating a health programme, one can select a research site where (according to statistical information) the programme has been successful (for example in promoting

condoms) and where this is not the case. Comparison can help analyze which factors contribute to success and which factors constrain programme success.

Contrast sampling can also be used to select participants for focus group discussions. Within each group the informants should be relatively homogenous in terms of the important dimensions of the study; but for the different groups you select contrasting cases (e.g. men and women; younger and older; users and not users).

### 5 Sampling Typical Cases

When selecting informants, anthropologists often want to identify typical cases. These cases need to be selected with the help of key informants who know what a typical case is. For example, in a study on infertility, the aim can be to identify an infertile woman who can be interviewed to capture the way in which women typically deal with the condition. This clearly should not be a woman with a relatively high educational background and therefore one with more access to information on infertility than others in her community. Rather, it should be a woman with an average educational background and economic status.

Typical cases can also be selected after a first exploratory round of interviews using a maximum variation approach in which common strategies are identified. 'Typical' cases are selected for more in-depth interviewing from the initial sample.

### B Probability Sampling Methods for Quantitative Studies

In quantitative studies we aim to measure variables and generalize findings obtained from a *representative sample* from the total population. In such studies, we will be confronted with the following questions:

- What is the group of people (*study population*) from which we want to draw a sample?
- How many people do we need in our sample?
- How will these people be selected?

The study population has to be clearly defined, for example, according to age, sex, and residence. Apart from people, a study population may consist of villages, institutions, records, etc.

Each study population consists of *study units*. The way one defines the study population and the study unit depends on the problem to be investigated.

**Figure 30.1** Examples of Study Population and Study Units

<i>Problem</i>	<i>Study population</i>	<i>Study unit</i>
Malnutrition related to weaning in district X	All children 6-24 months of age in District X	One child between 6-24 months in District X
High drop-out rates in primary schools in District Y	All primary schools in District Y	One primary school in District Y
Inappropriate record-keeping for leprosy patients registered in hospital Z	All records on leprosy patients in hospital Z	One record on a leprosy patient registered in hospital Z

If researchers want to draw conclusions that are valid for the whole study population, they should take care to draw a sample in such a way that it is representative of that population.

---

A REPRESENTATIVE SAMPLE has all the important characteristics of the population from which it is drawn.

---

*If one intends to interview 100 mothers to obtain a complete picture of the weaning practices in District X one would have to select these mothers from a representative sample of villages. It would be unwise to select them from only one or two villages as this might give a distorted or biased picture. It would also be unwise to interview only mothers who attend the under-fives clinic, as those who do not attend this clinic may wean their children differently.*

An important issue influencing the choice of the most appropriate sampling method is whether a sampling frame is available, that is, a listing of all the units that compose the study population.

If a sampling frame does exist or can be compiled, *probability sampling* methods can be used. With these methods, each study unit has an equal or at least a known probability of being selected in the sample. The following probability sampling methods will be discussed:

- Simple random sampling;
- Systematic sampling;
- Stratified sampling;
- Cluster sampling;
- Multi-stage sampling.

### 1 *Simple Random Sampling*

This is the simplest form of probability sampling. To select a simple random sample one needs to:

- Make a numbered list of all the units in the population from which one wants to draw a sample;
- Decide on the size of the sample (this will be discussed later in section 5);
- Select the required number of sampling units, using a ‘lottery’ method or a table of random numbers (Annex 32.1 explains how to use a table of random numbers).

*A simple random sample of 50 students is to be selected from a school of 250 students. Using a list of all 250 students, each student is given a number (1 to 250), and these numbers are written on small pieces of paper. All the 250 papers are put in a box, after which the box is shaken vigorously to ensure randomization. Then, 50 papers are taken out of the box and the numbers are recorded. The students belonging to these numbers will constitute the sample.*

## 2 Systematic Sampling

---

In SYSTEMATIC SAMPLING individuals are chosen at regular intervals from the sampling frame. Ideally we randomly select a number to tell us where to start selecting individuals from the list.

---

A systematic sample is to be selected from 1,200 students from a school. The sample size selected is 100. The sampling fraction is:

$$\frac{100 \text{ (sample size)}}{1,200 \text{ (study population)}} = \frac{1}{12}$$

The sampling interval is therefore 12. The number of the first student to be included in the sample is chosen randomly, for example by blindly picking one out of twelve pieces of paper, numbered 1 to 12. If number 6 is picked, then every twelfth student will be included in the sample, starting with student number 6, until 100 students are selected: the numbers selected would be 6, 18, 30, 42, etc.

Systematic sampling is usually less time-consuming and easier to perform than simple random sampling. However, there is a risk of bias as the sampling interval may coincide with a systematic variation in the sampling frame. For instance, if we want to select a random sample of days on which to count clinic attendance, systematic sampling with a sampling interval of 7 days would be inappropriate, as all study days would fall on the same day of the week, which might, for example, be a market day.

## 3 Stratified Sampling

The simple random sampling method described above does not ensure that the proportion of individuals with certain characteristics in the sample will be the same as those in the whole study population.

---

If it is important that the sample includes representative groups of study units with specific characteristics (for example, residents from urban and rural areas, or different age groups), then the sampling frame must be divided into groups, or STRATA, according to these characteristics. Random or systematic samples of a predetermined size will then have to be obtained from each group (stratum). This is called STRATIFIED SAMPLING.

---

Stratified sampling is only possible when we know what proportion of the study population belongs to each group we are interested in.

An advantage of stratified sampling is that one can take a relatively large sample from a small group in the study population. This allows one to get a sample that is big enough to enable researchers to draw valid conclusions about a relatively small group without having to collect an unnecessarily large (and hence expensive) sample of the

other, larger groups. However, in doing so, one is using unequal sampling fractions and it is important to correct for this when generalizing our findings to the whole study population.

*A survey is conducted on household water supply in a district comprising 20,000 households, of which 20% is urban and 80% rural. It is suspected that in urban areas the access to safe water sources is much more satisfactory. A decision is made to include 100 urban households (out of 4,000, which gives a 1 in 40 sample) and 200 rural households (out of 16,000, which gives a 1 in 80 sample). Because we know the sampling fraction for both strata, the access to safe water for all the district households can be calculated.*

#### 4 Cluster Sampling

It may be difficult or impossible to take a simple random sample of the units of the study population, either because a complete sampling frame does not exist or because of other logistical difficulties (e.g., visiting people scattered over a large area may be too time-consuming). However, when a list of groupings of study units is available (e.g., villages or schools) or can be easily compiled, a number of these groupings can be randomly selected.

---

The selection of groups of study units (clusters) instead of the selection of study units individually is called CLUSTER SAMPLING.

---

Clusters are often geographic units (e.g., districts, villages) or organizational units (e.g., clinics, training groups).

*In a study of the knowledge, attitudes, and practices related to family planning in a region's rural communities, a list is made of all the villages. Using this list, a random sample of villages is chosen and all the adults in the selected villages are interviewed.*

#### 5 Multi-Stage Sampling

---

A MULTI-STAGE SAMPLING procedure is carried out in phases and usually involves more than one sampling method.

---

In very large and diverse populations sampling may be done in two or more stages. This is often the case in community-based studies, in which the people to be interviewed are from different villages, and the villages have to be chosen from different areas.

*In a study of a district's pit latrine utilization, 150 homesteads are to be visited for interviews with family members as well as for observations on types and the cleanliness of latrines. The district is composed of six wards and each ward has between six and nine villages. The following four-stage sampling procedure could be performed:*

- 1 *Select three wards out of the six by simple random sampling.*
- 2 *For each ward, select five villages by simple random sampling (15 villages in total).*
- 3 *For each village select ten households. Because simply choosing households in the centre of the village would produce a biased sample, the following systematic sampling procedure is proposed:*
  - *Go to the centre of the village.*
  - *Choose a direction in a random way: spin a bottle on the ground and choose the direction the bottleneck indicates.*
  - *Walk in the chosen direction and select every third or every fifth household (depending on the size of the village) until you have the ten you need. If you reach the boundary of the village and you still do not have ten households, return to the centre of the village, walk in the opposite direction and continue to select your sample in the same way until you have ten. If there is nobody in a chosen household, take the next nearest one.*
- 4 *Decide beforehand whom to interview (for example the head of the household, if present, or the oldest adult who lives there and who is available).*

The main advantages of cluster and multi-stage sampling are that:

- a sampling frame of individual units is not required for the whole population. Initially a sampling frame of clusters is sufficient. Only within the clusters that are finally selected do we need to list and sample the individual units.
- The sample is easier to select than a simple random sample of similar size because the individual units in the sample are physically together in groups, instead of scattered all over the study population.

Their main disadvantage is that:

- compared to simple random sampling, there is a larger probability that the final sample will not be representative of the total study population. The likelihood of the sample not being representative depends mainly on the number of clusters selected in the first stage. The larger the number of clusters, the greater the likelihood that the sample will be representative.

### 3 Bias in Sampling

---

BIAS in sampling is a systematic error in sampling procedures that leads to a distortion in the results of the study.

---

In Module 26 we discussed how the use of faulty data collection tools could lead to biased results. Bias can also be introduced as a consequence of *improper sampling procedures* that result in the sample not being representative of the study population.

*A study was conducted to determine the health needs of a rural population to plan primary health care activities. However, a nomadic tribe, which represented one-third of the total population, was left out of the study. As a result, the study did not give a picture of the health needs of the total population.*

There are several possible sources of bias in sampling. The best known source of bias is non-response (see Module 26, section 3).

*In a survey trying to establish the percentage of men who has had a sexually transmitted disease (STD), it was found that many men refused to answer certain questions such as whether they had recently visited prostitutes or had attended an STD clinic in the past month. It is possible that these men feared the consequences of disclosing such sensitive information to an outsider. The researchers may therefore underestimate the prevalence of STDs in the community.*

Non-response is encountered mainly in studies where people are being interviewed or asked to fill in a questionnaire. They may refuse to be interviewed or forget to fill in the questionnaire. The problem lies in the fact that non-respondents in a sample may exhibit characteristics that differ systematically from the characteristics of respondents.

There are several ways to deal with this problem and reduce the possibility of bias:

- Data collection tools (including written introductions for the interviewers to use with potential respondents) have to be pretested. If necessary, adjustments should be made to ensure better cooperation.
- If non-response is due to absence of the subjects, follow-up of non-respondents may be considered.
- If non-response is due to refusal to cooperate, an extra, separate study of non-respondents may be considered to discover to what extent they differ from respondents.
- Another strategy is to include additional people in the sample, so that non-respondents who were absent during data collection can be replaced. However, this can only be justified if their absence was very unlikely to be related to the topic being studied.

The bigger the non-response rate, the more necessary it becomes to take remedial action. It is important in any study to mention the non-response rate and to discuss honestly whether and how it might have influenced the results.

Other sources of bias in sampling may be less obvious, but are at least as serious:

- *Studying volunteers only.* This produces selectivity (or bias) in assigning subjects to various groups:

*You intend to study whether a programme on how to stop smoking will be effective in helping the smokers in a hypertension clinic. You invite those who would like to attend to register themselves. You plan to compare the percentage who stop smoking among those who attend the programme with those who do not. However, it is likely that those who register themselves are those who are strongly motivated to stop smoking while those who are not motivated do not join the programme.*

The fact that volunteers are motivated to participate in the study may mean that they are also different from the study population on the factors being studied. It is better to avoid using non-random procedures that introduce the element of choice.

- *Sampling of registered patients only.* Patients reporting to a clinic are likely to differ systematically from people seeking treatment at home.
- *Missing cases of short duration.* In studies of the prevalence of disease, cases of short duration are more likely to be missed. This may often mean missing fatal cases, cases with short episodes, and mild cases.
- *Seasonal bias.* It may be that the problem under study exhibits different characteristics in different seasons of the year. For this reason, data on the prevalence and distribution of malnutrition in a community, for example, should be collected during all seasons rather than just at one time. When investigating health services' performance, to take another example, one has to take into account the fact that towards the end of the financial year shortages may occur in certain budget items which may affect the quality of services delivered.
- *Tarmac bias.* Study areas are often selected because they are easily accessible. However, these areas are likely to be systematically different from more inaccessible areas.

#### 4 Ethical Considerations

If the recommendations from a study will be implemented in the entire study population, one should aim at drawing a sample from this population in a representative way. If part way through the research new evidence suggests that the sample was not representative, this should be mentioned in any publication concerning the study, and care must be taken not to draw conclusions or make recommendations that are not justified.

#### 5 Sample Size

Having decided how to select our sample, we now have to determine our *sample size*.

It is a widespread belief among researchers that the bigger the sample, the better the study becomes. This is not necessarily true. In general it is much better to increase the *accuracy* of data collection (for example by improving the training of interviewers or by better pretesting of the data collection tools) than to increase sample size after a certain point.



In *qualitative studies* the aim is not to be representative of the population. The validity, meaningfulness and insights generated from qualitative inquiry have more to do with the information richness of the cases selected, and the analytical qualities of the researcher than with the sample size. There are no rules for sample size in qualitative inquiry. It depends on what one wants to know, the purpose of the inquiry, and practical factors. Often qualitative researchers refer to the redundancy criterion: that is when no new information is forthcoming from new sampled units.

Funders of the research are not likely to accept such a vague statement on sample size. To satisfy their needs and also those of supervisors, one can use pragmatic criteria in defining sample size, considering the amount of time it costs to do and transcribe the interviews and the number of sub-groups from which one will select respondents. A qualitative study with 40 informants is a relatively large study. Generally qualitative comparative studies have at least ten informants per group.

In *quantitative studies*, as a general rule we can say that the desirable sample size is determined by the expected variation in the data: the more varied the data is, the larger the sample size we will need to attain the same level of accuracy.

For surveys and analytical studies precise calculations can usually be made that indicate the desirable sample size. Examples of such calculations follow below.

For exploratory studies, we cannot say more than that the sample size needs to be large enough to reflect important variations in the population, but small enough to allow for intensive study methods.

*In a study on attitudes toward family planning, one may decide to interview three categories of informants (non-users, female users, and male users), and start with 20 to 30 interviews per category. This number could be increased if the data obtained for each category do not indicate a certain trend or if results are conflicting.*

---

The eventual sample size is usually a compromise between what is *desirable* and what is *feasible*.

---

The *feasible sample size* is determined by the availability of resources:

- time;
- manpower;
- transport;
- money.

Remember that if persons are to be interviewed in their homes, it is often more time consuming to go and trace the people than to actually do the interview. In addition, remember that resources are not only needed to collect the information, but also to analyze it!

If many variables are included in the study (which is usually the case in an exploratory type of study) the sample size should be relatively small to avoid problems during analysis. If one has few variables, one can afford to have a larger sample.

The following general rules may help to determine the *desirable sample size* of any given study:

- The desirable sample size depends on the expected variation in the data (of the most important variables): the more varied the data are, the larger the sample size one would need to attain the same level of accuracy. For exploratory studies it is important that the sample size is large enough to reflect important variations in the population, but small enough to allow for intensive study methods.
- The desirable sample size also depends on the number of cells one will have in the cross-tabulations required to analyze the results. A rough guideline is to have at least 20 to 30 study units per cell.

---

## Assignment

- 1 Review your study objectives and suggest what types of study sites would be relevant for your study. Suggest 2-3 criteria to be used in selecting study sites.
  - 2 What are the study units from which you will select a sample?
  - 3 Will your sampling strategy be purposeful or is a probability sampling method a better approach? Or will you combine these two types of sampling?
  - 4 Which specific purposeful or probability sampling method will you use in your study? Why is this method appropriate?
-



**MODULE 31**

**ETHICAL CONSIDERATIONS  
IN APPLIED HEALTH RESEARCH**

# ETHICAL CONSIDERATIONS IN APPLIED HEALTH RESEARCH

## Objectives

At the end of this Module, participants should be able to:

- list key ethical criteria for applied health research;
- identify potential harm to informants caused by applied health research and suggest ways to minimize harm and maximize the study's benefits;
- understand the importance of informed consent and ways in which it can be dealt with in anthropological research.

## Contents

- 1 Introduction to Basic Ethical Principles
- 2 Avoiding Harm to Subjects and Maximizing Benefits
- 3 Obtaining Informed Consent Before the Study or Interview Begins
- 4 Protecting the Privacy of Informants
- 5 The Need for Ethics Committees

## 1 Introduction to Basic Ethical Principles

Three basic principles have dominated ethical discussions on research with human subjects. These include the principle of respect for persons, the principle of beneficence, and the principle of justice. These principles imply that researchers must not only respect individual autonomy but also the health and well-being of subjects. Before and during the development of data collection techniques, one needs to consider whether or not the research procedures are likely to cause any physical or emotional harm to the informants. Harm may be caused, for example, by:

- violating informants' right to privacy by posing sensitive questions or by gaining access to records that may contain personal data;
- increasing social stigma attached to certain groups of informants by disclosing sensitive information to the general public, the media or the authorities;
- observing the behaviour of informants without their consent;
- failing to observe or respect certain cultural values, traditions, or taboos.

## 2 Avoiding Harm to Subjects and Maximizing Benefits

When conducting research, it is the researcher's responsibility to protect the well-being of the informants. To ensure this, ethical guidelines have been developed to guide professional conduct during the process of data collection, data analysis and publication of the results of social science research. These ethical considerations have to precede any research procedure. The researcher must be aware of any possible harm her or his research might cause to the informants *before* she or he starts collecting the data.

Applied Health Research should only be conducted if potential harm can be minimized and if some benefit can be derived for individuals and society. In the larger context, the long-term social and scientific consequences that may result from investigations must be taken into account (Marshall 1991).

AIDS research is fraught with ethical dilemmas. A social scientist conducting research on the way in which families cope with HIV/AIDS, for example, can seriously stigmatize families in settings where HIV/AIDS is not openly discussed. If the objective of the research is publically known, a visit to any household could have social consequences. A discussion about the consequences of HIV/AIDS to the family may not only be stigmatizing, but also extremely distressing to the respondents. When conducting such highly sensitive research, it is nearly impossible to guarantee the privacy of the respondents and avoid harm. Local informants should be consulted on the best way to conduct the study. It may be best, for example, to not even mention HIV/AIDS to the community leader where the study is done and instead to explain that the objective of the study is to find out how families cope with chronically ill family members. In addition, the researchers should establish links with HIV/AIDS-counsellors, so that informants who are distressed by the interview can be referred to them. Finally, researchers engaging in such studies should consider seriously the potential benefits of the study for the informants. If there are few, then clearly the benefits do not outweigh the risk that harm will be done to the informants.

Research subjects are often aware of the possible dangers of their cooperation in research. They may decide not to cooperate, resulting in high non-response rates for questionnaires or high refusal rates for interviews. They may also deliberately give incorrect answers. Of course, this will have a detrimental effect upon the validity of the research. Ethical conduct will therefore also help to improve the validity of the research outcome and at the same time increase the acceptability and participation of the study subjects in the study.

Ethical problems in the determination of research's risks and benefits may arise when the researcher has no control over the use of the research data. Related to this is the problem of *allegiance*: where do the researchers stand in terms of loyalty? Are they accountable to the sponsors of the research, their institution or to the community in which the research was conducted? For example, a pharmaceutical company may contract a social scientist to do a series of focus group discussions prior to testing the acceptability of various dosage forms of a new painkiller for children. The main aim of the survey is to develop a marketing strategy to increase the market share of the painkiller by expanding its use in children. The painkiller is more expensive than paracetamol, which is the medicine of choice for children according to the national drug formulary, and it has more side effects. By engaging in such a study the researchers are confronted with a conflict of interest. They themselves will benefit by the study as they will be paid for it, but the results of the study appear to have no benefit for the informants. In fact, if the marketing campaign is successful, the results could possibly contribute to harm for children, in terms of adverse effects. To be able to judge possible conflicts of interest between the subjects in the research and the sponsors, researchers should always inform the research subjects about the funding sources of their studies and clarify in what way research results will be used by the sponsoring agencies.

In our view, the researchers should primarily be responsible to their informants and they should make sure that the people who have participated in the research get a chance to benefit from the study results first. This means that the researcher has a moral obligation to present his or her results to the communities where the studies have been done; and to promote use of the results in the interests of the community. One way in which this can be done is to organize feedback sessions in which not only the results of the study are presented and validated by people in the community, but also community members get a chance to formulate recommendations for action. This can be a research activity in itself, requiring, for example, a series of focus group discussions with various groups of informants in the community (older men, younger men, older women, younger women, et cetera). Researchers can build on existing mechanisms or develop new ones to facilitate dialogue between the community and health care institutions which cater to community health care needs.

### 3 Obtaining Informed Consent before the Study or Interview Begins

*Informed consent* means that the researcher asks informants for permission to include them in the study after information about the research objectives has been provided. Informed consent consists of three key elements:



- the provision of adequate information, including a description of research purposes and the study's risks and benefits;
- comprehension of information by the informant(s);
- voluntary participation.

Obtaining informed consent can be very difficult when language barriers exist or in research among vulnerable populations (for example, ethnic minorities, hospitalized patients, or children). Also, in cultural settings with different ethical standards and ideas about a person's autonomy and privacy, the principle of informed consent takes on different meanings. Informed consent may also affect participation in research, as was the case in The Philippine study into prescribing practices, and the responses to interview questions (people tend to give 'desirable' answers).

For some studies, including observational techniques, informed consent would ruin the purpose of the research. If health centre workers would be informed about the objectives of a research study into, for example, the extent of unhygienic practices in the administration of injections, then they might change their normal practice. If individuals are aware that they are under study they often change their behaviour as a result (Hawthorne effect). For a researcher interested in actual behaviour and not in the behaviour 'as it should be', informed consent could be counterproductive. Some observational techniques such as concealed (unobtrusive) observation make use of covert researchers. This 'dishonesty' is often justified by stating that this is the only way to get data which is not obtainable by other means. Another justification for such covert research methods is that valid research data is in the interest of public health (as is the case with the determination of unhygienic administration of injections in health centres) or in the interest of the research subjects because they help to develop more effective interventions (as is the case with unobtrusive participant observation in a gay cruising area in order to develop an appropriate AIDS prevention campaign).

When intending to do participant observation on a certain topic in a community, anthropologists tend to ask informed consent from key gate-keepers, such as the community leaders. They explain their objectives and study methodology to these people and when consent is given it is considered a proxy for that of the individual community members. When conducting participant observation without explicit informed consent from the individuals who are studied, it is extremely important that informants' privacy be guaranteed. Also, it is essential that after the study has been done, the community is informed of the work done by the anthropologist and given a chance to comment on the findings and to benefit from them. This may seem self-evident, but one would only need to take a look at anthropological PhD theses available in university libraries in Europe and the United States and question the writers on whether or not their informants also have a copy of the product of their fieldwork. Most likely the majority of them has not left even a single copy of the work in the field where the data was obtained. In publishing the results of the study the anthropologist may need to decide not only to give informants pseudonyms, but also to disguise the name of the community where the study was done, to ensure privacy for the informants and avoid harm to the community.

#### 4 Protecting the Privacy of Informants

In all research, but especially when sensitive questions have to be asked about, for example, sexual practices or the use of illicit drugs or the use of abortions, one should omit names and addresses from the questionnaires. The privacy of informants has to be guaranteed. This means that one should conduct the research completely anonymously. Some researchers even decide to give villages or places fictive names in order to protect the research subjects. In the informed consent procedures, informants should be told about the ways in which privacy will be guaranteed. Anthropologists conducting participant observation have to be especially careful in protecting their informants in the entries they make in their notebooks and diaries. The descriptions of people, even when fictive names are given, can be used to define their identity. One way to avoid this is by using codes for key background variables which have no clear meaning to people who happen to find the diary.

#### 5 The Need for Ethics Committees

In medical research ethical clearance is nearly always required by the involved funding agencies and health institutions. Unfortunately such procedures are not always well established in the social sciences. Ideally research institutions involved in social science research on health issues should set up ethical committees to review and approve proposals. Criteria that can be used in such a process are:

- quality of the research design;
- competency of the researchers;
- funding sources listed and possible conflicts of interest specified;
- acknowledgement of identified possible negative consequences of the study;
- the researchers describe how they intend to minimize harm and maximize the study's benefits;
- the informed consent procedure is described, including a description of the way in which voluntary participation will be ensured. It should also include a copy of the full information on the study's purpose and methods which will be given to informants, and the way in which comprehension will be checked, and consent given (this can be a main discussion point, as when researchers have reason not to follow informed consent procedures, they will need to explain why, and put forward alternatives to ensure respondents' privacy and informed consent before results are published);
- mechanisms for ensuring privacy and confidentiality of the informants and communities.

#### References

Marshall, P.

- 1991 'Research Ethics in Applied Medical Anthropology.' In: C.E. Hill (ed.), *Training Manual in Applied Medical Anthropology*. Washington DC: American Anthropological Association, Special Publication No. 27.

---

## Group Exercise

Select an ethical committee consisting of two teachers and three students (try to make the committee as heterogenous as possible).

Conduct the following role play: The committee is newly established and wants to discuss a number of ethical issues in order to get to know each other and as a basis for its future policy. The students not participating in the committee act as a staff member from a research institution specialized in anthropology of health and health care. They resist strict rules on the conduct of research as they tend to do participant observation, using natural conversations and unobtrusive observations as main methods of study. The committee asks them to pose ethical questions and dilemmas to them concerning their own research projects. These are written down and given to the committee. (Ten minutes time is allowed to reflect on the questions to be posed individually), followed by 15 minutes tea or coffee break in which the five-person committee selects a number of the questions and dilemmas and elects a chairperson.

A plenary meeting is then held by the committee in which three key questions/dilemmas are discussed under the chair's guidance with the aim of defining a position on the issue. The staff who is present at the committee meeting is allowed to comment on the position taken by the committee.

---



**PLAN FOR DATA COLLECTION**

# PLAN FOR DATA COLLECTION

## Objectives

At the end of this Module, the participants should be able to:

- identify and discuss the most important points to be considered when preparing a plan for data collection;
- determine what resources are necessary and available to carry out your study;
- describe typical problems that may arise during data collection and how they may be solved;
- prepare a plan for data collection for the research proposal you are developing.

## Contents

- 1 Introduction
- 2 Stages in the Data Collection Process

Annex 32.1 Training Interviewers

\* Adapted from Module 12, Health Systems Research Training Series, Volume 2

## 1 Introduction

Where are we now in the development of our research proposal? Look again at the diagram in Module 13 that introduces the research methodology. We have just finished some crucial theoretical sessions, in which we have defined:

- what information we want to collect to answer the research questions implied in our objectives (Module 16);
- what approach we will follow to collect this information (module 15);
- what techniques and tools we will use to collect it (Module 17-19);
- where we want to collect the data, how we will select our sample, and how many subjects we will include in our study (Module 20).

Now we enter a new phase in the development of our research methodology: planning our fieldwork. We have to plan concretely how we will collect the data we need, how we will analyze it, and how we can test the most crucial parts of our methodology. Finally, we will have to develop a plan for project administration and monitoring and to budget the resources necessary to carry out the study.

A *plan for data collection* can be made in two steps:

- Listing the tasks that have to be carried out and who should be involved, making a rough estimate of the time needed for the different parts of the study, and identifying the most appropriate period in which to carry out the research.
- Actually scheduling the different activities that have to be carried out each week in a work plan.

Ideally, a pretest of the data collection and data analysis procedures should be made. The advantages of conducting the pretest *before* we finalize our proposal is that we can draft the work plan and budget based on realistic estimates, as well as revise the data collection tools before we submit the proposal for approval.

However, if this is not possible (for example, because the proposal is drafted far from the field, and there are no similar research settings available close to the workshop site), the field test may be done after finishing the proposal, but long enough before the actual fieldwork to allow for a thorough revision of data collection tools and procedures.

A plan for data collection should be developed so that:

- You will have a clear overview of what tasks have to be carried out, who should perform them, and the duration of these tasks;
- You can organize both human and material resources for data collection in the most efficient way; and
- You can minimize errors and delays that may result from lack of planning (for example, the population not being available or data forms being misplaced).

It is likely that while developing a plan for data collection you will identify problems (such as limited manpower) that will require modifications to the proposal. Such modifications might include adjustment of the sample size or extension of the period for data collection.

## 2 Stages in the Data Collection Process

Three main stages can be distinguished in the data collection process:

- Stage 1: Permission to proceed
- Stage 2: Data collection
- Stage 3: Data handling

### *Stage 1 Permission to Proceed*

Consent must be obtained from the relevant authorities, individuals, and the community in which the project is to be carried out. This may involve organizing meetings at national or provincial level, at district, and at village level. For clinical studies this may also involve obtaining written informed consent.

Most likely the principal investigator will be responsible for obtaining permission to proceed at the various levels. The health research unit in the ministry of health or the institution organizing the course may assist in obtaining permission from the national level. In many countries research proposals have to be screened for scientific and ethical integrity by national research councils.

### *Stage 2 Data Collection*

When collecting our data, we have to consider the logistics: who will collect what, when, and with what resources and quality control.

#### *A Logistics of Data Collection*

##### *WHO will collect WHAT data?*

When allocating tasks for data collection, it is recommended that you first list them. Then you may identify who could best implement each of the tasks. If it is clear beforehand that your research team will not be able to carry out the entire study by itself, you might look for research assistants to assist in relatively simple but time-consuming tasks.

*In a study into the effects of improvements in delivery care on utilization of these services the following task division could be proposed:*

**Figure 32.1** Allocating Tasks for Data Collection

<i>Task</i>	<i>To be carried out by</i>
Record study	Research team
Focus group discussions with health staff before and after individual staff interviews	Research team
Individual health staff interviews	Research team
Participant observation in clinic	Principal investigator
Interviews with mothers (community based) before and after delivery	Research assistants, under supervision of research team



*HOW LONG will it take to collect the data for each component of the study?*

- 1 Consider:
  - The time required to reach the study area(s).
  - The time required to ‘walk around’ and build rapport in the community
  - The time required to locate the study units (persons, groups, records). If you have to search for specific informants (e.g. users or defaulters of a specific service), it might take more time to locate informants than to interview them.
  - The number of visits required per study unit. For some studies it may be necessary to visit informants a number of times, for example, if the information needed is sensitive and can be collected only after informants are comfortable with the investigator or if observations have to be made more than once (follow-up of pregnant mothers or malnourished children). Allowing time for follow-up of non-respondents should also be considered.
  - The time required for quality control of the collected data to judge their validity.
  - The time required for keeping fieldnotes on the research process.
  - The time required for preliminary analysis of the data.
  
- 2 Calculate the number of interviews that can be carried out each day (e.g. 4).
  
- 3 Calculate the number of days needed to carry out the interviews. For example:
  - You need to do 200 interviews.
  - Your research team of 5 people can do  $5 \times 4 = 20$  interviews per day.
  - You will need  $200 : 20 = 10$  days for the interviews.
  
- 4 Calculate the time needed for the other methods used in the study (for example, 5 days for familiarization and rapport building, 5 days for focus group discussions, 3 days for participant observation).
  
- 5 Determine how much time the research team can devote to the fieldwork. If time required according to calculation is more, it may be necessary to recruit assistants for certain components of the study, for example for conducting interviews.

Recruiting research assistants for data collection may ease the task of the research team, but it must be remembered that the training and supervision of research assistants also requires time (see Annex 32.1). The team has to carefully balance the advantages and disadvantages. If none of the team members has previous research experience they might prefer designing a study that they can carry out themselves without or with only a minimum of assistance.

If research assistants are required, consider to what extent local health workers can be used. They have the advantage of being acquainted with the local situation. Obviously, they should never be involved in conducting interviews to evaluate the performance of their own health facility or in studies on people’s self-care practices in their own catchment area. Local staff from related services (teachers, community development) or students might help out. Sometimes village health workers or community members can collect certain parts of the data.

It is always advisable to slightly overestimate the period needed for data collection to allow for unforeseen delays. In fact, it is often difficult to implement the fieldwork strictly according to plan, as you may encounter unforeseen problems such as weather conditions or breakdowns in transport. Your basic philosophy in planning fieldwork should be: be flexible!

*IN WHAT SEQUENCE should data be collected?*

In general, it is advisable to start with analysis of data already available. This is essential if the sample of respondents is to be selected from the records. Another rule of thumb is that qualitative research techniques (such as focus group discussions) that are devised to focus the content of questionnaires should be carried out before finalization of the questionnaires. If the focus group discussions are to provide feedback on issues raised in larger surveys, however, they should be conducted after preliminary analysis of the questionnaires.

To use time and transport efficiently, data to be drawn from different sources in one locality should be collected at the same time (for example, interviews with staff in a health centre, observations of equipment available in the centre, and interviews with mothers living nearby should be scheduled together).

*WHEN should the data be collected?*

The actual time that the data will be collected will be determined by the type of data to be collected and the demands of the project. Consideration should be given to:

- the availability of research team members and research assistants;
- the appropriate season(s) to conduct the fieldwork (if the problem is season-related or if data collection would be difficult during certain periods);
- the accessibility and availability of the sampled population; and
- public holidays and vacation periods.

**B Ensuring Quality**

It is extremely important that the data we collect is of good quality, that is to say, reliable and valid. Otherwise we may come up with false or misleading conclusions. In the previous Modules possible sources of data distortion (*bias*) have been discussed. Biases we should try to prevent include:

- a Deviations from the sampling procedures set out in the proposal.
- b Variability or bias in observations or measurements made because:
  - our study subject changes his or her behaviour as a consequence of the research. For example, a subject may act more positively while being observed;
  - we use unstandardized measuring instruments. For example, we may use unstandardized weighing scales or imprecise or no guidelines for interviewing;
  - researchers themselves vary in what they observe or measure (observer variability). For example, researchers may be selective in their observations (observer bias); measure, question, or note down answers with varying accuracy or follow different approaches (one being more open, friendly, probing than the other).
- c Variations in criteria for measurement or for categorizing answers because we changed them during the study.

There are a number of measures that can be taken to prevent and partly correct such distortions, but remember: prevention is far better than cure! Cure usually implies ‘surgery’: you may have to cut out the bad parts of your data or, at best, devise crutches.

There are several other aspects of the data collection process that will help ensure data quality. You should:

- a* Prepare a fieldwork manual for the research team as a whole, including:
  - guidelines on sampling procedures and what to do if respondents are not available or refuse to cooperate (see Module 20);
  - a clear explanation of the purpose and procedures of the study, which should be used to introduce each interview; and
  - instruction sheets on how to ask certain questions and how to record the answers.
- b* Select your research assistants, if required, with care. Choose assistants who are:
  - from the same educational level;
  - knowledgeable concerning the topic and local conditions; but not the object of study themselves; and
  - not biased concerning the topic (for example, health staff are usually not the best interviewers for a study on traditional health practices).
- c* Train research assistants carefully in all topics covered in the fieldwork manual as well as in interview techniques (see Annex 32.1) and make sure that all members of the research team master interview techniques such as:
  - asking questions in a neutral manner;
  - not showing by words or expression what answers one expects;
  - not showing agreement, disagreement, or surprise; and
  - recording answers precisely as they are provided, without sifting or interpreting them.
- d* Pretest research instruments and research procedures with the whole research team, including research assistants.
- e* Take care that research assistants are not placed under too much stress (requiring too many interviews a day; paying per interview instead of per day).
- f* Arrange for on-going supervision of research assistants. If, in case of a larger survey, special supervisors have to be appointed, supervisory guidelines should be developed for their use.
- g* Devise methods to assure the quality of data collected by all members of the research team. For example, quality can be assured by:
  - requiring interviewers to check whether the questionnaire is filled in completely before finishing each interview;
  - asking the supervisor to check at the end of each day during the data collection period whether the questionnaires are filled in completely and whether the recorded information makes sense;
  - having the researchers review the data during the data analysis stage to check whether data are complete and consistent.

### *Stage 3 Data Handling*

Once the data have been collected, a clear procedure should be developed for handling and storing them.

- First, it is necessary to check that the data gathered are complete and accurate (see section on quality control above).
- At some stage questionnaires will have to be numbered. Decide if this should be done at the time of the interview or at the time the questionnaires are stored.
- Identify the person responsible for storing data and the place where they will be stored.
- Decide how data should be stored. Record forms should be kept in the sequence in which they have been numbered.

---

## Individual Assignment

Make a plan for data collection, considering the points below:

### 1 *Permission to proceed*

- Which organizations or individuals should be approached to obtain permission to proceed with the research project?
- Who will ask for permission? When? What procedures will be followed?

### 2 *Data Collection*

List the different components of your study (including time for familiarization) and the number of interviews, observations, or measurements required.

- Calculate for each component how many interviews or observations can be done per day by one person.
- Decide if you need extra assistance.
- In case you need research assistants: For which components of the research? How many research assistants? Who would be the right persons to assist you and for how many days will you need them?
- How will you train them? (place, timing, content, duration, trainers).
- How will you ensure their supervision?
- How will the quality of the data be checked and by whom?

### 3 *Data handling*

- How will the questionnaires/checklists be numbered?
- How will the data be stored and who has the final responsibility for storing the data?

### 4 *Ethical considerations*

Make sure that your data collection process is ethical in all respects:

- How have you planned to obtain informed consent from your informants? Are there any categories of informants that need special consideration (e.g. children, sick persons, mentally disabled individuals)?
  - Are certain parts of the research focused on sensitive issues? How will you handle problems that may arise?
  - Do certain parts of your research require extra attention to assure confidentiality? How will you handle this issue?
-

## Annex 32.1 Training Interviewers

### 1 Interviewers' Tasks

During the fieldwork, interviewers (or research assistants) may work independently or together with one of the researchers. If they go out independently, they may have to carry out the following tasks:

- do the sampling in the field (for example sampling of households within a village and/or sampling of individuals to be interviewed within households);
- give a clear introduction to the interviewee concerning the purpose and procedures of the interview;
- perform the interviews. Obviously it is best to give interviewers standard questionnaires to administer. It is not wise to assign the more difficult tasks of performing highly flexible interviews or focus group discussions to research assistants.

It is imperative that interviewers be trained by the researchers so they can carry out their tasks accurately and correctly, according to the procedures developed by the researchers. Interviewers should not be left to develop their own procedures. If each interviewer is allowed to develop his own approach, bias is almost certain to result.

The training of interviewers may take 2 to 3 days. The first day may be devoted to theory, followed by 1 or 2 days of practical training, depending on the local circumstances and the nature of the study.

### 2 Theoretical Training

Interviewers must be thoroughly familiar with the objectives of the research project and the methodology. Therefore, it is recommended that they be provided with a copy of the research protocol and that the most relevant sections be discussed thoroughly, including:

- statement of the problem;
- objectives;
- data collection tools to be used (an overview);
- sampling procedures (if sampling has to be done in the field);
- plan for data collection; and
- plan for data analysis.

It is important at this stage that the interviewer trainees get ample opportunity to ask questions.

Then a more in-depth discussion should follow concerning the data collection tools (questionnaires and possibly checklists) that are to be used by the interviewers. For each and every question they should know *why* the information is required.

Interviewers should be taught basic interview techniques, such as:

- asking questions in a neutral manner;
- not showing by words or expression what answers one expects;
- not showing agreement, disagreement, or surprise; and

- recording answers to open questions precisely as they are provided, without sifting or interpreting them.

Clear instructions should be given, as well, concerning to what extent the interviewer is allowed to alter the phrasing of questions, if it seems necessary, and whether he or she should probe for answers.

For questions that have pre-categorized answers it should be made clear whether the possible answers should be mentioned by the interviewer during the interview or not (usually they are not to be mentioned). There should be no misunderstandings concerning how to record answers and observations.

Finally, explanations should be given concerning how the interviewer should introduce him or herself to the interviewee, what to say concerning the purpose of the study, how to ask for consent, and how to close the interview.

### 3 *Practical Training*

Practical training in interviewing is essential. This may be provided in two stages.

First, *role plays* can be performed, during which one trainee assumes the role of the interviewer and another plays the interviewee. Other trainees and the trainers (researchers) should observe carefully what happens and give constructive feedback right after the role play. Then roles can be changed, until each trainee has had the chance to practice each type of interview at least once.

Second, a *field test* should be conducted, which will serve two purposes: the training of the interviewers and a (further) test of the data collection tools. A test of the tools is essential if a previous field test resulted in important changes or if the questionnaire(s) were translated into a local language after the first field test. If the interviewer trainees are involved in the proper phrasing of questions it will definitely strengthen their interest and commitment.

The field test is best carried out in groups of 2 to 3 persons, with each team including at least one trainer and one trainee. Note that after the field test constructive criticism of each interview should be made, starting from the moment the interviewee was first approached up to their last meeting.

### 4 *Supervision of Interviewers*

If interviewers are used, responsibility for the research remains with the researchers. To guarantee the quality of the data collected it is important to supervise the interviewers' performance, especially at the beginning of the data collection period. If they are going out into the field independently, plans could be made to accompany them on selected visits or to question a small sample of the interviewees concerning key aspects of the interview. Interviewers can also accompany each other at regular intervals to observe each other's interviewing techniques and to identify differences in conduct. Ways to prevent such differences could be discussed during regular fieldwork meetings.

As a further quality control check, it is important that the interviewer's name (or interviewer's code) appears on each questionnaire/checklist so that it is possible to ask for clarification if certain information is not clear.





**MODULE 33**

**PRETESTING**

# PRETESTING

## Objectives

At the end of this Module, the participants should be able to:

- describe the components of a pretest or pilot study that will allow you to test and, if necessary, revise your proposed research methodology before starting the actual data collection;
- plan and carry out pretests of research components for the proposal being developed.

## Contents

- 1 What is a Pretest?
- 2 Pretest in the Actual Research Area

Annex 33.1 Summary of Points to Assess During a Pretest or Pilot Study

\* Adapted from Module 14, Health Systems Research Training Series, Volume 2

## 1 What is a Pretest?

---

A PRETEST usually refers to a small-scale trial of a particular research component.

A PILOT STUDY is the process of carrying out a preliminary study, going through the entire research procedure with a small sample.

---

### *Why Do We Carry out a Pretest or Pilot Study?*

A pretest or pilot study serves as a trial run that allows us to identify potential problems in the proposed study. Although this means extra effort at the beginning of a research project, the pretest or pilot study enables us, if necessary, to revise the methods and logistics of data collection before starting the actual fieldwork. As a result, a good deal of time, effort, and money can be saved in the long run. Pretesting is simpler and less time consuming and costly than conducting an entire pilot study. Therefore, we will concentrate on pretesting as an essential step in the development of the research projects.

If a study consists of various research phases, for example a small-scale exploratory study using qualitative tools followed by a survey, then pretesting should be done at the beginning of each phase.

The following aspects of the research methodology can be evaluated during pretesting:

- 1 Reactions of the respondents to the research procedures can be observed in the pretest to determine:
  - availability of the study population and how respondents' daily work schedules can best be respected;
  - acceptability of the methods used to establish contact with the study population;
  - acceptability of the questions asked; and
  - willingness of the respondents to answer the questions and collaborate with the study.
  
- 2 The data collection tools can be pretested to determine:
  - whether the tools you use allow you to collect the information you need and whether those tools are reliable. You may find that some of the data collected are not relevant to the problem or are not in a form suitable for analysis. This is the time to decide not to collect these data or to consider using alternative techniques that will produce data in a more usable form;
  - how much time is needed to administer the questionnaire, to conduct observations or group interviews, and to make measurements;
  - whether there is any need to revise the format or presentation of questionnaires or interview schedules, including whether:
    - the sequence of questions is logical;
    - the wording of the questions is clear;
    - translations are accurate;

- space for answers is sufficient;
  - there is a need to pre-categorize some answers or to change closed questions into open-ended questions;
  - there is a need to adjust the coding system; or
  - there is a need for additional instructions for interviewers (e.g. guidelines for ‘probing’ certain open questions).
- 3 Sampling procedures can be checked to determine:
- whether the instructions to obtain the sample are followed in the same way by all staff involved;
  - how much time is needed to locate individuals to be included in the study.
- 4 Staffing and activities of the research team can be checked, while all are participating in the pretest, to determine:
- how successful the training of the research team has been;
  - what the work output of each member of the staff is;
  - how well the research team works together;
  - whether logistical support is adequate;
  - the reliability of the results when instruments or tests are administered by different members of the research team;
  - whether staff supervision is adequate.

The pretest can be seen as a period of extra training for the research team in which sensitivity to the needs and wishes of the study population can be developed.

- 5 Procedures for data processing and analysis can be evaluated during the pretest. Items that can be assessed include:
- appropriateness of data master sheets and dummy tables and ease of use;
  - effectiveness of the system for quality control of data collection;
  - appropriateness of statistical procedures (if used);
  - clarity and ease with which the collected data can be interpreted.
- 6 The proposed work plan and budget for research activities can be assessed during the pretest. Issues that can be evaluated include:
- appropriateness of the amount of time allowed for the different activities of planning, implementation, supervision, coordination, and administration;
  - accuracy of the scheduling of the various activities.

### *When Do We Carry out a Pretest?*

You might consider:

- Pretesting at least your data collection tools, either during the workshop, or, if that is impossible, immediately thereafter, in the actual field situation.
- Pretesting the data collection and data analysis process 1-2 weeks before starting the fieldwork with the whole research team (including research assistants) to allow time for revisions.

## 2 Pretest in the Actual Research Area

All the issues mentioned above may have to be reviewed again during a pretest in the actual field situation. Other issues, such as the functioning of the research team, including newly recruited and trained research assistants, and the feasibility of the work plan, can only be tested in the research area. An important output of the pretest should be a fully developed work plan.

If choices have to be made as to what to include in the pretest, the following considerations may be helpful:

- What difficulties do you expect in the implementation of your proposal? Think of possible sources of bias in data collection techniques and sampling and ethical issues you considered during the preparation of your plan for data collection (Module 17). Can some of these potential problems be overcome by adapting the research design?
- If you feel you have little experience with a certain data collection technique you may want to do some extra practice during the pretest.
- Which parts of your study will be most costly and time consuming? Questionnaires used in large surveys, for example, should always be tested. If many changes are made the instruments should be pretested again. If a questionnaire or interview schedule has been translated into a local language, the translated version should be pretested as well.

It is highly recommended that you analyze the data collected during the pretest immediately. Then finalize and if necessary, adjust the master sheets. Make totals for each variable included in the master sheets. Fill in some dummy tables and prepare all the dummy tables you need keeping your research objectives in mind. Do this even if you plan to analyse the data by computer. By doing this you will detect shortcomings in your questionnaires that still can be corrected!

In the pretest or pilot study should be involved:

- The research team, headed by the principal investigator.
- Any additional research assistants or data collectors that have been recruited.

How long should the pretest or pilot study last? The time required for a pretest or pilot study will be determined by a number of factors:

- The size and duration of the research project (the longer the study will take, the more time you might reserve for the test run);
- The complexity of the methodology used in the research project.

Keep in mind that this is the last chance you will have to make adjustments that will help to ensure the quality of your fieldwork. If you have a two months fieldwork period, you might reserve at least one week for pretesting your data collection tools, analyzing the results of the pretest, finalizing your tools, and elaborating the work plan.

### Individual Assignment

- 1 Determine what parts of the methodology you would like to test. Include all data collection tools, if possible.
  - 2 Prepare a short list of questions you wish to answer during the pretest (see Annex 33.1 for suggestions).
-

### Annex 33.1 Summary of Points to Assess During a Pretest or Pilot Study

1	<i>Reactions of respondents to your research procedures</i>	<i>Acceptable</i>	<i>Not acceptable</i>	<i>Suggestions</i>
	Availability of sample needed for full study Work schedules of population that may affect their availability Desire of population to participate Acceptability of questions Clarity of the language used			
2	<i>The data collection tools</i>	<i>Acceptable</i>	<i>Not acceptable</i>	<i>Suggestions</i>
	Whether the tools provide the information you need and are reliable Time needed for administering each of the data collection tools Presentation of questions and format of questionnaire Accuracy of translation Pre-categorizing of questions Coding system and coding guidelines Handling and administering the tools			
3	<i>Sampling procedures</i>	<i>Acceptable</i>	<i>Not acceptable</i>	<i>Suggestions</i>
	Whether the instruction to obtain the sample are used uniformly by all staff Time needed to locate the individuals to be included in the study			
4	<i>Preparation and effectiveness of research team</i>	<i>Acceptable</i>	<i>Not acceptable</i>	<i>Suggestions</i>
	Adequacy of staff training Output of each team member Team dynamics Reliability of tools when administered by different team members Accuracy of interpretation Appropriateness of plan for supervision			

5	<i>Procedures for data processing and analysis</i>	<i>Acceptable</i>	<i>Not acceptable</i>	<i>Suggestions</i>
	Use of data master sheets Effectiveness of data quality control Appropriateness of statistical procedures Ease of data interpretation			
6	<i>Schedule for research activities</i>	<i>Acceptable</i>	<i>Not acceptable</i>	<i>Suggestions</i>
	Amount of time allowed for: <ul style="list-style-type: none"> <li data-bbox="154 565 434 588">– field trips for data collection</li> <li data-bbox="154 605 277 628">– supervision</li> <li data-bbox="154 645 306 668">– administration</li> <li data-bbox="154 685 314 708">– analysis of data</li> </ul> Sequence of activities			



**MODULE 34**

**FIELDWORK EXERCISE**

## FIELDWORK EXERCISE

### Objectives

At the end of this Module, the participants should be able to:

- understand how a focused ethnographic interview is performed.
- conduct a rapid ethnographic appraisal in a community by practising ethnographic interviews and participant observation as well as the construction of an ethnographic record.

### Literature

Spradley, J.P.

1979 *The Ethnographic Interview*. New York: Holt, Rinehart and Winston, pp. 55-77.

Bentley, M.E. et al.

1988 'Rapid Ethnographic Assessment: Application in a Diarrhoea Management Program.' *Social Science & Medicine* 27 (1): 107-116.

### Contents

- 1 Objectives of the Fieldwork Exercise
- 2 The Focus of the Exercise: Diarrhoeal Diseases in Young Children

## 1 Objectives of the Fieldwork Exercise

For the ethnographer, participant observation combined with semi-structured interviews are the most important data gathering techniques. The technique of ethnographic interviewing is used in order to discover the categories of meaning for the particular culture. Interviewing is useful for eliciting what people think, and how one individual's perceptions compare with another's. Such comparisons help identify shared values in the community, values that motivate behaviour. Participant observation complements the information gathered in the interviews. It is also useful for validation of the results (do individuals actually *do* what they *say* they do?), and for directing further research.

During this course, a two-day fieldwork exercise will be performed in a rural setting. The main objective of this exercise is that participants will be able to practise some aspects of the conventional ethnographic fieldwork techniques in a 'real' setting. While multi-method research techniques are normally used to complement each other in an ethnographic study, in the attempt to be holistic and learn as much as possible about a particular culture, participants in this exercise are required *only* to practise the conducting of an ethnographic interview and of some participant observation, as well as the completion of field note records.

Ethnographic interviewing and the taking of field notes were discussed in detail in Module 18a. Qualitative research in general and participant observation in particular usually requires a long period of stay in the community. In this course this is not possible. Therefore we have opted for the Rapid Ethnographic Appraisal technique in which a focus is selected. In this Module we will briefly discuss the focus chosen for the fieldwork exercise: diarrhoeal diseases. A group of anthropologists (Bentley et al. 1988) have designed rapid ethnographic assessment procedures for the study on diarrhoeal diseases.

## 2 The Focus of the Exercise: Diarrhoeal Diseases in Young Children

Diarrhoeal diseases represent a relevant focus for fieldwork practice because of its contribution to health problems in developing countries, and its central place in the child survival strategies of national and international health agencies (Pelto, Bentley & Pelto 1990).<sup>\*</sup> Diarrhoeal diseases are also relatively easily identified, globally distributed, and culturally patterned beliefs and practices play a tremendously important role (see Figure 34.1).

\* See also the special issue of *Social Science and Medicine* Volume 27 Number 1 (1988), devoted to the 'Anthropological Studies of Diarrhoeal Illness.'

**Figure 34.1** Cultural Construction of Diarrhoeal Illness: Interrelationship of Social Factors, Illness Experience, Help Seeking and Outcome (Source: Weiss 1980: 6)

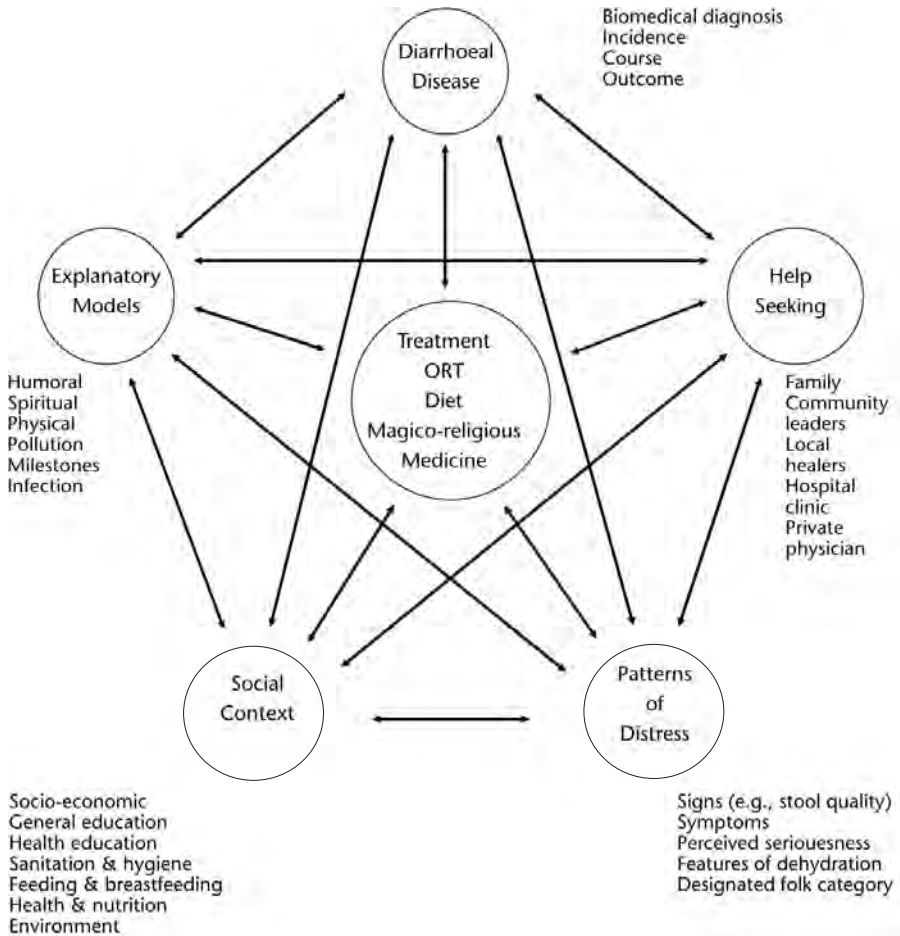

Anthropological contributions to diarrhoeal disease control programmes are well documented in the recent literature. Kendall (1990) cites the importance of understanding popular health beliefs, knowledge and behaviour in order to provide effective planning of health education. In Honduras, for example, the absence of the folk term *empacho* in the official oral rehydration therapy (ORT) promotion campaign led many people to believe that oral rehydration salts (ORS) were not useful for treating diarrhoea attributed to *empacho* (Scrimshaw & Hurtado 1988).

In most developing countries, it is common to use traditional practices for home management of diarrhoea in association with Western pharmaceuticals. This practice often leads to negative outcomes (Nations & Rebhun 1988; Kendall 1990). The inappropriate use of pharmaceuticals such as antibiotics or anti-diarrhoeal preparations in self-care of diarrhoea is an increasingly significant problem in the developing world. Health planners and programme managers are often unaware of traditional practices

in the case management of diarrhoeal diseases at home and overlook these behaviours in their ORT promotion campaigns.

For the fieldwork exercise and its preparation we will use interview and observation guidelines which will be provided to the participants under the title *Health Seeking Behaviour on Childhood Diarrhoeal Disease among the Rural Philippines*. In this research brief a framework is developed which enables us to understand how Philippine mothers think and react to their children's diarrhoeal diseases. It includes many of the concepts we have dealt with in the first five Modules of this course such as explanatory models (EMs), the existence of medical pluralism, patterns of resort, cultural definitions of illness and causation, and people's perceptions of the gravity of particular illness episodes interacting with their assessment of economic cost and likelihood of cure.

Components of the explanatory model on diarrhoeal diseases include:

- A classification of the disease and illness names;
- Their relative severity;
- The signs and symptoms that characterize each category;
- The causes of these illnesses;
- Home remedies; and
- Treatment by providers outside the home.

Key research questions for the fieldwork exercise (see *Health Seeking Behaviour on Childhood Diarrhoeal Disease among the Rural Philippines*) include the following:

- What are the emic, culture-specific explanatory models, including folk taxonomies of childhood diarrhoea; and how do these affect people's choices of diarrhoea management?
- To what extent do people within a particular cultural setting share a single explanatory model of diarrhoea?
- What are the patterns of health seeking behaviour for those with childhood diarrhoeal diseases in terms of onset, recognition, diagnosis and treatment, and outcome?
- What treatments do people use in self-care of diarrhoea in young children?
- Which environmental, economic, behavioural, and socio-cultural factors influence the acceptance or non-acceptance of oral rehydration therapy (ORT), and influence effective, appropriate use of ORT in management of childhood diarrhoeal illness?

## Additional References

Fetterman, D.M.

- 1989 *Ethnography Step by Step*. Applied Social Research Methods Series Volume 17. London: Sage Publications.

Kendall, C.

- 1990 'Public Health and the Domestic Domain: Lessons from Anthropological Research on Diarrhoeal Diseases.' In: J. Coreil & J.D. Mull (eds.), *Anthropology and Primary Health Care*. Boulder, Colorado: Westview Press.

Nations, M. & L.A. Rebhun

- 1988 'Mystification of a Simple Solution: Oral Rehydration in North-East Brazil.' *Social Science and Medicine* 27 (1): 25-38.

Pelto, P.J., M.E. Bentley & G.H. Pelto

- 1990 'Applied Anthropological Research Methods: Diarrhoea Studies as an Example.' In: J. Coreil & J.D. Mull (eds.), *Anthropology and Primary Health Care*. Boulder: Westview Press.

Scrimshaw, S.C.M. & E. Hurtado

- 1988 'Anthropological Involvement in the Central American Diarrhoeal Disease Control Project.' *Social Science and Medicine* 27 (1): 97-107.

Weiss, M.G.

- 1988 'Cultural Models of Diarrhoeal Illness.' *Social Science and Medicine* 27 (1): 5-16.

---

## Exercise

- 1 In the class, participants will practise an ethnographic interview with local mothers having a child under five years of age, using interview guidelines. This is done to pretest the interview guidelines. A translator will be provided. Before and after the pretest, the interview guidelines will be reviewed in plenary sessions.
  - 2 A two-day period of fieldwork practice will be conducted in a rural setting. Participants will make a short field visit to the health centre and then travel to the village. At the village site, participants will be divided into small groups. Each group will interview two key informants and two mother-respondents at their places of residence. All group members will participate by asking questions with the assistance of a Philippino translator. Each participant will be responsible for at least one key informant or mother-respondent in order to be sure that all the information needed is collected and completely recorded.

Before the end of each interview, participants should make sure that the field notes also cover contextual information (for example, epidemiological data, information on the health care system, general social and economic conditions, etc.). The field notes should contain all answers to the questions in the interview guidelines. Verbatim information should be recorded as much as possible.
  - 3 After the completing of the fieldwork, the participants will discuss in the class the problems that arose: the handling of fieldwork, the conducting of ethnographic interviews, the practising of observation and the recording of field notes.
-





**PLAN FOR DATA PROCESSING AND ANALYSIS**

## PLAN FOR DATA PROCESSING AND ANALYSIS

### Objectives

At the end of this Module, the participants should be able to:

- identify important issues related to sorting, quality control, and processing of data;
- describe how data can best be analyzed and interpreted based on the objectives and variables of the study;
- prepare a plan for the processing and analysis of data (including data master sheets and dummy tables) for the research proposal they are developing.

### Contents

- 1 Introduction
- 2 Sorting Data
- 3 Performing Quality Control Checks
- 4 Data Processing: Categorizing and Coding
- 5 Data Processing: Manually or by Computer
- 6 Data Analysis
- 7 Conclusion

- Annex 35.1 Questionnaire for Exercise
- Annex 35.2 Data Master Sheet for Exercise, Part 2
- Annex 35.3 Frequency Tables for Exercise, Part 3
- Annex 35.4 Cross-Tabulation for Exercise, Part 4
- Annex 35.5 Analysis of Responses to Open-Ended Questions for Exercise, Part 5

\* Adapted from Module 13, Health Systems Research Training Series, Volume 2

## 1 Introduction

At the start of this session, all participants will be asked to fill in a questionnaire (see Annex 35.1) to be used later in an exercise on data processing and analysis.

Why is it necessary to prepare a plan for processing and analysis of data? Such a plan helps the researcher assure that at the end of the study:

- all the information he or she needs has indeed been collected;
- (s)he has not collected unnecessary data that will never be analyzed.

This implies that the plan for data processing and analysis must be made after careful consideration of the objectives of the study as well as the list of variables.

The procedures for the analysis of data collected through qualitative and quantitative techniques are quite different. Therefore, one must also consider the type(s) of study and the different data collection techniques used when making a plan for data processing and analysis.

For *qualitative data*, it is a matter of describing, summarizing, and interpreting data obtained for each study unit or for each group of study units. Here the researcher starts analyzing while collecting the data so that questions that remain unanswered (or new questions that come up) can be addressed before data collection is over.

For *quantitative data*, the starting point in analysis is usually a description of the data for each variable for all the study units included in the sample.

Preparation of a plan for data processing and analysis will provide you with better insight into the feasibility of the analysis to be performed as well as the resources that are required. It also provides an important review of the appropriateness of your data collection tools.

Note: The plan for processing and analysis of data must be prepared *before* the data is collected in the field so that it is still possible to make changes in the list of variables or the data collection tools.

### *What Should the Plan Include?*

When making a plan for data processing and analysis the following issues should be considered:

- sorting data;
- performing quality control checks;
- data processing; and
- data analysis.

## 2 Sorting Data

An appropriate system for sorting data is important for facilitating subsequent processing and analysis. If you have different study populations (for example village health workers, village health committees, and the general population), you obviously would number the questionnaires or field notes separately.

In a comparative study, it is best to sort the data right after collection into the two or three groups that you will be comparing during data analysis.

*In a study concerning the reasons for low acceptance of family planning services, users and non-users would be basic categories; in a study of the reasons why nurses object to being posted in rural areas, rural and urban nurses would be basic categories; in a case-control study obviously the cases are to be compared with the controls.*

It is useful to number the questionnaires, and field notes, belonging to each of these categories separately right after they are sorted.

*The questionnaires administered to users of family planning services could be numbered  $U_1, U_2, U_3$ , etc., and those for the non-users  $N_1, N_2, N_3$ , etc.*

---

### Exercise, Part 1: Processing and Analyzing Questionnaires

The questionnaire that was completed at the beginning of this session will now be used to determine the relationship between cigarette smoking and episodes of coughing during the past 2 days. Discuss what would be the most appropriate way of processing and analyzing the questionnaires.

---

## 3 Performing Quality Control Checks

Usually the data have already been checked in the field to ensure that all the information has been properly collected and recorded. Before and during data processing, however, the information should be checked again for *completeness and internal consistency*.

- If a questionnaire has not been filled in completely you will have *missing data* for some of your variables. If there are many missing items in a particular questionnaire, you may decide to exclude the whole questionnaire from further analysis.
- If an inconsistency is clearly due to a mistake made by the researcher or assistant (for example, if a person in an earlier question is recorded as being a non-smoker, whereas all other questions reveal that he is smoking), it may still be possible to check with the person who conducted the interview and to correct the answer.
- If the inconsistency is less clearly a mistake in recording, it may be possible (in a small-scale study) to return to the respondent and ask for clarification.
- If it is not possible to correct information that is clearly inconsistent, you may consider excluding this particular part of the data from further processing and analysis. If a certain question produces ambiguous or vague answers throughout, the whole question should be excluded from further analysis.

Note: A decision to exclude data should be considered carefully, as it may affect the validity of the study. You should keep an accurate count of how many answers or questionnaires you have had to exclude because of incompleteness or inconsistency, and discuss this point in your final report.

If you process your data by computer, quality control checks must also include a verification of how the data has been transformed into codes and subsequently entered into the computer.

#### 4 Data Processing: Categorizing and Coding

Data processing involves:

- a categorizing the data;
- b coding; and
- c summarizing the data on master sheets.

##### A *Categorizing*

Decisions have to be made concerning how to categorize responses.

In exploratory studies using qualitative techniques such as participant observation and ethnographic interviewing, variables have not been identified prior to data analysis. Data processing and analysis in such studies is an ongoing process. In preliminary analysis central themes are identified for further analysis. Researchers often use these topics in their interview guides and checklists as initial categorization. These topics are then defined as codes (or labels) and used to further code the data. For a detailed description of the analysis of qualitative data see Module 25.

For *numerical variables*, the data are usually collected without any pre-categorization. Because you are often still discovering the range and the dispersion of the different values of these variables when you collect your sample (e.g. home – clinic distance for out-patients), decisions concerning how to categorize numerical data (and how to code them) are usually made *after* they have been collected.

For *categorical variables* that are investigated through closed questions or observation (for example, observation of the presence or absence of latrines in homesteads) the categories have been decided upon beforehand. In interviews, the answers to open-ended questions (for example: ‘Why do you smoke?’) can be pre-categorized to a certain extent, depending on the knowledge of possible answers. However, there should always be a category called ‘others, specify ...’, which can only be categorized afterwards. These responses should be listed and placed in categories that are a logical continuation of the categories you already have. Answers that are difficult or impossible to categorize may be put into a separate residual category called ‘others’, but this category should not contain more than 5% of the answers obtained.

Responses obtained from open-ended questions in interviews or self-administered questionnaires include:

- opinions of respondents on a certain issue;
- reasons for a certain behaviour; and

- description of certain procedures, practices, or beliefs/knowledge with which the researcher is not familiar.

Note that these data may also be obtained from questions asking for comments, following a closed question.

The data can be analyzed in three steps:

*Step 1* List the data for each question. Take care to include the source of each item you list (in the case of questionnaires, you can use the questionnaire number) so that you can place it in the original context if required.

How you will categorize qualitative data depends on the type of data requested.

In the case of data on opinions and reasons, there may be a limited number of possibilities. *Opinions* may range from (very) positive, neutral, to (very) negative. Data on *reasons* may require different categories depending on the topic and the purpose of your question. In Part 5 of the exercise you are asked to categorize the reasons why people smoke by grouping them in such a way that it is easy to find entry points for health education aimed at reducing smoking.

*Step 2* To establish your categories, first read through the whole list of answers. Then start giving codes for the answers that you think belong together.

*Step 3* Next try to find a label for each category. After some shuffling you usually end up with 4 to 6 categories. You should enter these categories on the questionnaire and on the master sheet.

Note again that you may include a category ‘others’, but that it should be as small as possible, preferably containing less than 5% of the total answers.

If you categorize your responses to open-ended questions in this way you can:

- report the percentage of respondents giving reasons or opinions that fall in each category; and
- analyze the content of each answer given in particular categories, to plan what actions should be taken (e.g. for health education).

Questions that ask for descriptions of procedures, practices, beliefs or knowledge (item 3) are usually not meant to be quantified although you may quantify certain aspects of them. The answers rather form part of a jigsaw puzzle that you have to put together carefully. When you are analyzing questions of this type you may find it useful to list and categorize responses.

## **B Coding**

If data are entered into a computer for subsequent processing and analysis, it is essential to develop a *coding system*.

---

**CODING** is a method used to convert (translate) the data gathered during the study into symbols appropriate for analysis.

---

For computer analysis, each category of a variable is usually given a number, for example, the answer 'yes' may be coded as 1, 'no' as 2 and 'no response' as 9.

The codes should be entered on the questionnaires (or checklists) themselves. When finalizing your questionnaire you should insert a box for the code in the right margin of the page for each question. These boxes should not be used by the interviewer. They are only filled in afterwards during data processing. Take care that you have as many boxes as the number of digits in each code.

**Note:** If you intend to process your data by computer, always consult a person experienced in computer processing before you finalize your questionnaire.

Also, if analysis is done by hand using data master sheets, it is useful to code your data. There are some coding conventions which researchers should observe:

Common responses should have the same code in each questions, as this minimizes mistakes by coders. For example:

<i>Yes (or positive response)</i>	<i>code - 1</i>
<i>No (or negative response)</i>	<i>code - 2</i>
<i>Don't know</i>	<i>code - 9</i>

Coding for open-ended questions can be done only after examining a sample of questionnaires. The most frequently occurring responses should be coded. It may be necessary to group similar types of responses into single categories, so as to limit their number. If there are too many categories it is difficult to make meaningful summaries during analysis.

Qualitative codes usually are labels which indicate the topic that is recorded and relevant to the study. Such codes are used in analyzing the field notes.

### **C Data Master Sheet**

If data are processed by hand, it is often most efficient to summarize the raw research data in a so-called *data master sheet* to facilitate analysis. On a master sheet, all the answers of individual respondents are tallied by hand.

**Table 35.1** Example of a Master Sheet

Respondent number	Q1: Age (years)	Q2: Sex		Q4: Smoking			Q5: Number of cigarettes
		M	F	Yes	No	No response	
1	30	✓		✓			10
2	41		✓		✓		–
3	23		✓	✓			15-20
etc.							
Total							

Data are easier to tally from the master sheets than from the original questionnaires. Straight counts can be performed for background variables (such as sex, residence), and for all independent variables under study (such as smoker/non-smoker in the exercise).

Questionnaire data may be compiled by hand instead of using master sheets if it is difficult or impossible to put the information (such as answers to open-ended questions) in a master sheet. Hand compilation is also necessary if you want to go back to the raw data to make additional tabulations in which different variables are related to each other.

In a comparative study you should use different master sheets for the two or three groups you are comparing (e.g. users and non-users of family planning services). In a survey, it may be useful to have several master sheets depending on the nature and objectives of the study and whether you want to compare two or more groups. In the example given in the exercise, it is useful to have one data master sheet for people with episodes of cough and another for those without cough.

Note: Great care should be taken when filling in master sheets. You should verify that all totals correspond to the total number of study units (respondents). If not, all subsequent analytical work will be based on erroneous figures. There should be special columns for 'no response' or missing data, to arrive at accurate total figures.

## 5 Data Processing: Manually or by Computer

As you begin planning for data processing, you must make a decision concerning whether to process and analyze the data:

- manually, using data master sheets or manual compilation of the questionnaires; or
- by computer, for example, using a microcomputer and existing software or self-written programmes for data analysis.

It should be kept in mind that the personnel responsible for computer analysis should be consulted very early in the study, i.e. as soon as the questionnaire and dummy tables are finalized.



### *Hand Compilation*

Hand compilation is used when the sample size is small. Certain procedures will help ensure accuracy and speed.

- 1 If only one person is doing the compilation, use *manual sorting*. If a team of two persons work together, use either manual sorting or *tally counting*.
- 2 Manual sorting can be used only if data on each subject are on a different sheet(s) of paper.
- 3 To do manual sorting the basic procedure is to:
  - take one question at a time;
  - sort the questionnaires into different piles representing the various responses to the question (examples: male/female; used hospital/health centre/traditional practitioners);
  - count the number in each pile.

When you need to sort out subjects who have a certain combination of variables (e.g. females who used each type of health facility) sort the questionnaires into piles according to the first question, then subdivide the piles according to the response to the other question.

- 4 To do tally counting the basic procedure is:
  - One member of the compiling team reads out the information while the other records it in the form of a tally (e.g. 'III' representing three subjects or 'IIII' representing four subjects who have a particular variable).
  - Tally count for no more than two variables at one time (e.g. sex plus type of facility used). If it is necessary to obtain information on three variables (e.g. sex, time of attendance at health centre, and diagnosis), do a manual sorting for the first question, then tally count for the other two variables.
  - After tally counting, add the tallies and record the number of subjects in each group.
- 5 After doing either manual or tally counting check the total number of subjects/responses in each question to make sure that there has been no omission or double count.

Note: Researchers often assume that hand compilation is merely common sense and do not train their staff in the correct procedure. Many hours of work are subsequently wasted in trying to detect the source of errors due to double counts, wrong categorization, and omissions.

---

## Exercise, Part 2: Data Master Sheet

The questionnaires (or the two piles of questionnaires) will be divided among four or five groups of participants in such a way that everybody is involved in the exercise. Each group will be asked to summarize the data on a master sheet (see Annex 35.2) and to calculate totals. One group will put its data on a master sheet on a flip chart, so everyone can see and discuss it.

---

### *Computer Compilation*

Before you decide to use a computer, you have to be sure that it will save you time or that the quality of the analysis will benefit from it. Note that feeding the data into a computer costs time and money. The computer should not be used if your sample is small and the number of variables large. The larger the sample, the more beneficial the use of a computer will be. Also be sure that the necessary equipment is available as well as the necessary expertise.

Computer compilation consists of the following steps:

- 1 choosing an appropriate computer programme;
- 2 data entry;
- 3 verification or validation;
- 4 programming (if necessary);
- 5 computer outputs.

#### *1 Choosing an Appropriate Computer Programme*

A number of computer programmes are available on the market that can be used to process and analyze research data. The most widely used programmes are:

- LOTUS 1-2-3, a spreadsheet programme (from the Lotus Development Corporation).
- dBase (version III plus or IV), a data management programme (from Ashton-Tate).
- Epi Info (version 5), a very consumer-friendly programme for data entry and analysis, which also has a word processing function for creating questionnaires (developed by the Centers for Disease Control, Atlanta, and the World Health Organization, Geneva).
- SPSS, which is a quite advanced Statistical Package for Social Sciences (by SPSS Inc.).

If you intend to use a computer, you should ask advice from an experienced person concerning which programme is the most appropriate for your type of data. Note that Epi Info may be freely used and copied. All the other programmes have copyrights.

## 2 *Data Entry*

To enter data into the computer you have to develop a data entry format, depending on the programme you are using. However, it is possible to enter data using dBase (which is relatively good for data entry) and do the analysis in LOTUS 1-2-3 or SPSS.

After deciding on a data entry format, the information on the data collection instrument will have to be coded (e.g. Male: 1, Female: 2). During data entry, the information relating to each subject in the study is keyed into the computer in the form of the relevant code (e.g. if the first subject (identified as 0001) is a male (code 1) aged 25, the data could be keyed in as 001125).

## 3 *Verification*

During data entry, mistakes will definitely creep in. The computer can print out the data exactly as it has been entered, so the printout should be checked visually for obvious errors, (e.g. exceptionally long or short lines, blanks that should not be there, alphabetic codes where numbers are expected, obviously wrong codes). For example:

- codes 3-8 in the column for sex;
- codes above 250 when you had only 250 subjects.

If possible, computer verification should be built in. This involves giving the appropriate commands to identify errors.

*The computer can be instructed to identify and print out all subjects where the 'sex' column has a code 3-8.*

## 4 *Programming*

If you use computer personnel to analyze your data, it is important to communicate effectively with them. Do not leave the analysis to the computer specialist! You as a researcher should tell the computer personnel:

- the names of all the variables in the questionnaire;
- the location of these variables in relation to the data for one subject (i.e. the data format);
- how many subjects are to be analyzed and which groups are to be compared;
- whether any variables are to be recorded or calculated; and
- for which variables you need straight tabulations and which variables you would like to cross-tabulate.

A certain amount of basic training is needed to use any of the above-mentioned computer programmes and to give the appropriate commands.

## 5 Computer Outputs

The computer can do all kinds of analysis and the results can be printed. It is important to decide whether each of the tables, graphs, and statistical tests that can be produced makes sense and should be used in your report.

## 6 Data Analysis

### *Frequency Counts*

From the data master sheets, simple tables can be made with frequency counts for each variable. A frequency count is an enumeration of how often a certain measurement or a certain answer to a specific question occurs. For example:

<i>Smokers</i>	63
<i>Non-smokers</i>	<u>74</u>
<i>Total</i>	137

If numbers are large enough it is better to calculate the frequency distribution in percentages (*relative frequency*). This makes it easier to compare groups than when only absolute numbers are given. In other words, percentages standardize the data.

---

A PERCENTAGE is the number of units in the sample with a certain characteristic, divided by the total number of units in the sample and multiplied by 100.

---

*In the above example the calculation of the percentage answers the question: If I had asked 100 people who had an episode of coughing if they smoke cigarettes, how many would have answered 'yes'? The percentage of people answering 'yes' would be:*

$$\frac{63}{137} \times 100 = 46\%$$

A *frequency table* such as the following could then be presented:

**Table 35.2** Numbers of Smokers and Non-Smokers in the Sample

<i>Category</i>	<i>Frequency*</i>	<i>Relative frequency</i>
Smokers	63	46%
Non-smokers	74	54%
Total	137	100%

\* Missing data: 3

Note: Sometimes data are missing due to non-response or (in oral interviews) non-recording by the interviewer. Usually you do not use missing data in the calculation of percentages. However, the number of missing data is a useful indication of the quality of your data collection and, therefore, this number should be mentioned, for example as a note to your table (see Table 35.2, for example).

Be careful: ‘Don’t know’ is *not* to be taken as a non-response. If applicable, a category ‘don’t know’ should appear in the data master sheet and in the frequency table.

It is usually necessary to summarize the data from numerical variables by dividing them into categories. This process includes the following steps:

- 1 Inspect all the figures: What is their range? The range is the difference between the largest and the smallest measurement.
- 2 Divide the range in three to five categories. You can either aim at having a reasonable number in each category (e.g. 0-2 km, 3-4 km, 5-9 km, 10+ km for home – clinic distance) or you can define the categories in such a way that they all start with round numbers (e.g. 20-29 years, 30-39 years, 40-49 years, etc.).
- 3 Construct a table indicating how data are grouped and count the number of observations in each group.

When inspecting frequency distributions and ranges, you may still discover that certain data are incorrect. In this case, appropriate action must be taken, as described in section 3 (quality control checks).

---

### Exercise, Part 3: Frequency Tables

All groups of participants are asked to make a frequency distribution for the variables sex and age, using the information from the data master sheets in Part 2 of this exercise (see Annex 35.3 for examples of dummy tables). The totals will be put in a table on the flip chart.

---

#### *Cross-Tabulations*

In addition to making frequency counts for one variable at a time, it may be useful to combine information on two or more variables to describe the problem or to arrive at possible explanations for it. For this purpose it is necessary to design *cross-tabulations*.

Depending on the objectives and the type of study, three different kinds of cross-tabulations may be required:

- 1 Cross-tabulations which aim at describing the problem under study.
- 2 Cross-tabulations in which groups are compared to determine differences.
- 3 Cross-tabulations which focus on exploring relationships between variables.

When the plan for data analysis is being developed, the data are, of course, not yet available. However, to visualize how the data can be organized and summarized, it is useful at this stage to construct so-called *dummy cross-tabulations*.

---

A DUMMY TABLE contains all elements of a real table, except that the cells are still empty.

---

*In the exercise it would be useful to compare the answer to question 3 on coughing with the major independent variable smoking/non-smoking.*

**Table 35.3** Episodes of Cough in Smokers and Non-Smokers

	<i>Cough in last 2 days</i>	<i>No cough in last 2 days</i>	<i>Total</i>
Smokers			
Non-smokers			
Total			

In a research proposal, dummy tables should be prepared to show the major relationships between variables.

Note: It is extremely important to determine before you start collecting the data what tables you will need to assist you in looking for possible explanations of the problem you have identified. This will prevent you from collecting too little or too much data in the field. It will also save you much time in the data processing stage. Care should be taken not to embark on an unstructured comparison of all possible variables. The dummy tables to be prepared follow from the specific objectives of the study.

If we process the data by hand, we will have to tally how often each combination of outcomes of two variables occurs.

*If you asked how many smokers did cough in the last 2 days, how many non-smokers did so, how many smokers did not cough and how many non-smokers did not cough, you might obtain the following result:*

**Table 35.4** Episodes of Cough in Smokers and Non-Smokers

	<i>Cough in last 2 days</i>	<i>No cough in last 2 days</i>	<i>Total</i>
Smokers		       	
	11	52	63
Non-smokers		       	
	3	71	74
Total	14	123	137

There are two different ways to handle the data when doing the tallying. Either master sheets can be used or the original questionnaires can be sorted by hand.

In the latter case, you would go through the following steps for the above example:

- Divide the forms into two piles, one for smokers and one for non-smokers.
- Divide each pile into one for those without cough and one for those who had an episode of cough (we now have four piles).
- Count the number in each pile and fill in the table.

Some practical hints when constructing tables:

- If a dependent and an independent variable are cross-tabulated, the independent variable is usually placed vertically (at the left side of the table in a column) and the dependent variable horizontally along the top of the table.
- All tables should have a clear title and clear headings for all rows and columns.
- All tables should have a separate row and a separate column for totals to enable you to check if your totals are the same for all variables and to make further analysis easier.
- All tables related to each objective should be numbered and kept together so the work can be easily organized and the writing of the final report will be simplified.

To further analyze and interpret the data, certain calculations or statistical procedures must usually be completed. Especially in large cross-sectional surveys and in comparative studies, statistical procedures are necessary if the data is to be adequately summarized and interpreted. When conducting such studies it is, therefore, advisable to consult a person with statistical knowledge from the start in order that:

- correct sampling methods are used and an appropriate sample size is selected;
- decisions on coding are made that will facilitate data processing and analysis; and
- a clear understanding is reached concerning plans for data processing, analysis, and interpretation, including agreement concerning which variables need simple frequency counts and which ones need to be cross-tabulated.

A knowledge of elementary statistics will help you better understand the whole process of data analysis and interpretation.

---

### Exercise, Part 4: Cross-Tabulation

Each of the groups of participants who have a set of questionnaires are asked to cross-tabulate smokers/non-smokers and cough/no cough. All information will be put together in one cross-tabulation (on flip chart, see Annex 35.4).

After completion of the table, answer the following questions:

- What percentage of smokers had an episode of cough within the past 2 days?
  - Does this study confirm that smoking causes coughing?
- 

## 7 Conclusion

A plan for the processing and analysis of data includes:

- a decision on whether all or some parts of the data should be processed by hand or computer;
  - preparation of dummy tables for the description of the problem, the comparison of groups (if applicable), or the establishment of relationships between variables, guided by the objectives of the study;
  - a decision on the sequence in which tables should be analyzed, or in what order data should be analyzed;
  - a decision on how qualitative data should be analyzed;
  - an estimate of the total time needed for analysis and how long particular parts of the analysis will take;
  - a decision concerning whether additional staff are required for the analysis; and
  - an estimate of the total cost of the analysis.
- 

### Exercise, Part 5: Analysis of Response to Open-Ended Questions

Do the exercise in Annex 35.5 in small groups.

---



---

## Assignment

Prepare a plan for data processing and analysis, considering the following points:

**1 *Sorting and Quality Control of Data:***

- How will the sorting be done? When?
- What quality checks should be made? Who will do them? When?

**2 *Processing of Data:***

- How will you do it (by hand or by computer)? If by computer: do you have enough experience and is the necessary equipment available?
- Prepare data master sheets for your proposal.
- How many open-ended questions do you have that require categorizing or coding? Who will do the categorizing or coding? How much time will be required for data processing (taking into account the sample size)?

**3 *Analyzing and Interpreting the Data:***

- Using the specific objectives and the list of variables, prepare dummy tables in which you relate variables to each other to analyze possible (causal) relationships. Select the dummy tables that you plan to fill in before we have our workshop on data analysis and reporting.
  - Make estimates of the time and materials required for the analysis.
-



**ANALYSIS OF QUALITATIVE DATA**

# ANALYSIS OF QUALITATIVE DATA

## Objectives

At the end of this Module, the participants should be able to:

- describe the different steps in qualitative data analysis;
- have an insight into the ways qualitative data can be coded and ordered;
- summarize analyzed qualitative data;
- identify possible errors and omissions in the analysis of qualitative data.

## Contents

- 1 Introduction
- 2 Procedures for Processing and Displaying Qualitative Data
- 3 Drawing and Verifying Conclusions \*\*
- 4 Strategies for Testing or Confirming Findings

\* Adapted from Module 24, Health Systems Research Training Series, Volume 2

\*\* The main source of inspiration for writing this Module was: M.B. Miles & A.M. Huberman, 1984. *Qualitative Data Analysis, A Sourcebook of New Methods*. London: Sage Publications. Sections 3 and 4 of this Module are heavily abbreviated and adapted versions of their Chapter VII.

## 1 Introduction

Although procedures and outcomes of qualitative data analysis differ from those of quantitative data analysis, the principles are not so different. In both cases the researcher will have to:

- describe the sample population;
- order, reduce and/or code the data (data processing);
- display summaries of data in such a way that interpretation becomes easy;
- draw conclusions; and
- develop strategies for testing or confirming findings to prove their validity.

## 2 Procedures for Processing and Displaying Qualitative Data

### *Description of the Sample Population*

A useful first step in data processing, and in reporting findings, is a description of the informants. If your research population is large enough relevant background data may also be tabulated, on for example age, sex, occupation, education, or marital status, as is the practice in quantitative studies.

Since qualitative research usually involves small samples, sometimes a handful of key informants or focus group participants, you may need to provide more information to contextualize your data.

*Who were the key informants and what made them qualify as such? Who took part in the focus group discussions? How representative were the participants of the groups they represented? Under what circumstances were observations carried out? Who was observed (and who was not)? What were the reactions of those observed? In a focus group discussion, the notes of the recorder are very important, especially comments about the mood of the participants and the types of interactions.*

### *Ordering and Coding Data*

Interview and focus group discussion notes tend to be fragmented. Try to expand and organize these notes as soon as you can after the fieldwork. Immediately after each interview or focus group discussion, make sure to transform raw field notes into a well organized set of notes. It is not necessary to do a word-for-word transcription. You should have enough notes with key statements that can be expanded for analysis.

When analyzing such field notes you may find that, no matter how good the discussion guidelines were, the informants may jump from topic to topic. You have to try to systematize the information gathered. You may also find that your notes contain information that may not be immediately useful, or that may be totally irrelevant. You can exclude such notes but do not discard them since they may be useful later on.

To make the analysis easy, we have to order and reduce the data. Ordering is best done in relation to the research questions or discussion topics. If the data are limited and straightforward, we can simply mark all relevant data that belong to the same dis-

cussion topic by writing the number of that topic in the margin. If the data are complicated and bulky, it may be helpful to use codes for ordering the data.

*In trying to decide on coding categories, you can use one or both of the following methods:*

- *Deductive coding: Here, your theoretical framework generates the possible categories.*
- *Inductive coding: With this approach, your data generates the categories to use.*

You may need to review your data several times, doing preliminary or open coding before you decide on a final coding system. You can assign several codes to a single passage or word.

Unlike quantitative data, where codes are usually numbers, the codes for qualitative data are usually *labels* which can be easily remembered.

*In a focus group discussion about common illnesses in a village, you might code the data in the following way:*

<i>Cause</i>	<i>Causes of illness</i>
<i>Sign</i>	<i>Signs of illness</i>
<i>Tx1-Person</i>	<i>Persons sought for first form of treatment</i>
<i>Tx1-Med</i>	<i>Medicines used for first form of treatment</i>
<i>Tx1-Result</i>	<i>Result of first treatment</i>

Note: Devise codes that you and your co-researchers can easily understand. The codes should usually follow the topics of the discussion guide or of the checklist for observations.

### ***Summarizing Data: Statements about Issues and Graphics***

After ordering the data we will have to summarize them. The first step is to list the data that belong together. After coding the data, we list all the data that have been given the same code, e.g. all the different causes for a particular illness.

*In a study on the introduction of soft baby foods an issue may be: mothers' views of how diarrhoea is contracted by infants. When reading through all the answers to the relevant question(s) we may find, for instance, that mothers differentiate between general causes for contracting diarrhoea, like drinking bad water, and the cause of their own child having diarrhoea: bad luck.*

We may also gain insight by looking at the indigenous concepts that people use to explain their views.

*When discussing the causes of diarrhoea, informants may, for example, think that diarrhoea is a 'hot' condition. They would then naturally perceive 'heat' as being the actual cause of the diarrhoea and not a contaminated water supply. Hot-cold notions are common in traditional medical systems. Such concepts are also applied*

*by informants to their choice of medicines used to treat a number of health problems. If the cause of diarrhoea is excessive 'heat', they then consider it only logical to take 'cooling' medications.*

In answering the question 'What self-medication do people apply in case of childhood diarrhoea' a researcher may wish to make a qualitative statement, explaining how people interpret the signs of diarrhoea and what they consider appropriate treatment. Such qualitative statements may be accompanied by a table providing quantitative data on the pattern of treatment. The importance of the qualitative statement is that it explains how people perceive diarrhoea and its treatment and *why* a certain treatment is preferred. The quantitative data show *how often* specific causes and treatments were mentioned, and how often certain treatments were given.

### *Displays in Charts and Figures*

It is also possible to further summarize the data graphically in a *chart* (e.g. a matrix) or a *figure* (e.g. diagram, flow chart). This will be particularly helpful when there is a need to interpret large amounts of data. Diagrams, like matrices, are of great assistance in keeping an overview of the data collected, in guiding data analysis, and in generating explanatory insights.

### *Matrices*

*In a focus group discussion on changing weaning practices, the researchers listed the answers of young mothers concerning the introduction of soft foods and those of mothers above child-bearing age using the codes as outlined above. They then summarized these answers in a matrix:*

**Figure 36.1** Matrix on Introduction of Soft Baby Foods among Mothers of Different Age Groups

<i>Age groups</i>	<i>Onset soft food</i>	<i>Type of food</i>	<i>Frequency of sf/day</i>
Young mothers (20-30)	range: 4-7 months average: 6 months	- soft porridge - soft porridge with pound groundnuts - mashed potatoes, mashed fruits, soaked biscuits	1-2 times daily - depends on availability of mother and caretaker - depends on appetite of child
Mothers past child-bearing age (45)	range: 5-11 months average: 8.5 months	- soft porridge - soft fruits	1-2 times daily - depends on availability of mother and caretaker - depends on appetite of child

\* Youngest child of young mothers; oldest child of mothers above child bearing age.

- This type of matrix display made it easy for the researchers to conclude that:*
- younger mothers start giving soft foods, on average, 2.5 months earlier than the generation of their own mothers;
  - younger mothers use a larger variety of soft weaning foods than older mothers; and
  - the two generations do not seem to differ in the frequency with which they give/gave soft foods to their babies.

Matrices are the most common form of graphic display of qualitative data. They can be used to order information in many ways; for example, according to:

- time sequence (of procedures being investigated);
- type of informants (as in the example above);
- location of data collection;
- type of activity; or
- reasons for certain behaviour.

*Diagrams*

*The focus group discussion on changing weaning practices mentioned above might provide information on reasons for early or late weaning that we could satisfactorily summarize in diagrams:*

**Figure 36.2** Reasons for Early Introduction of Soft Foods by Young Mothers

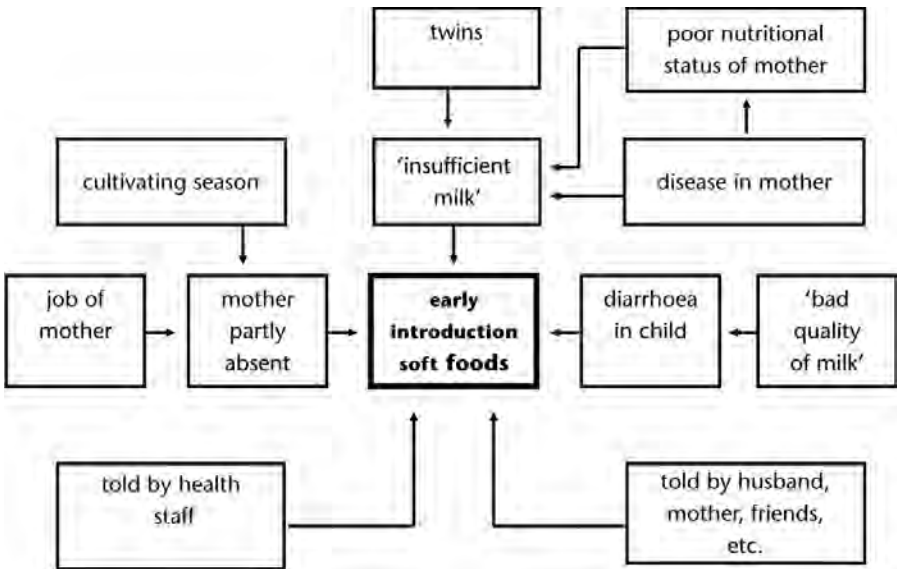

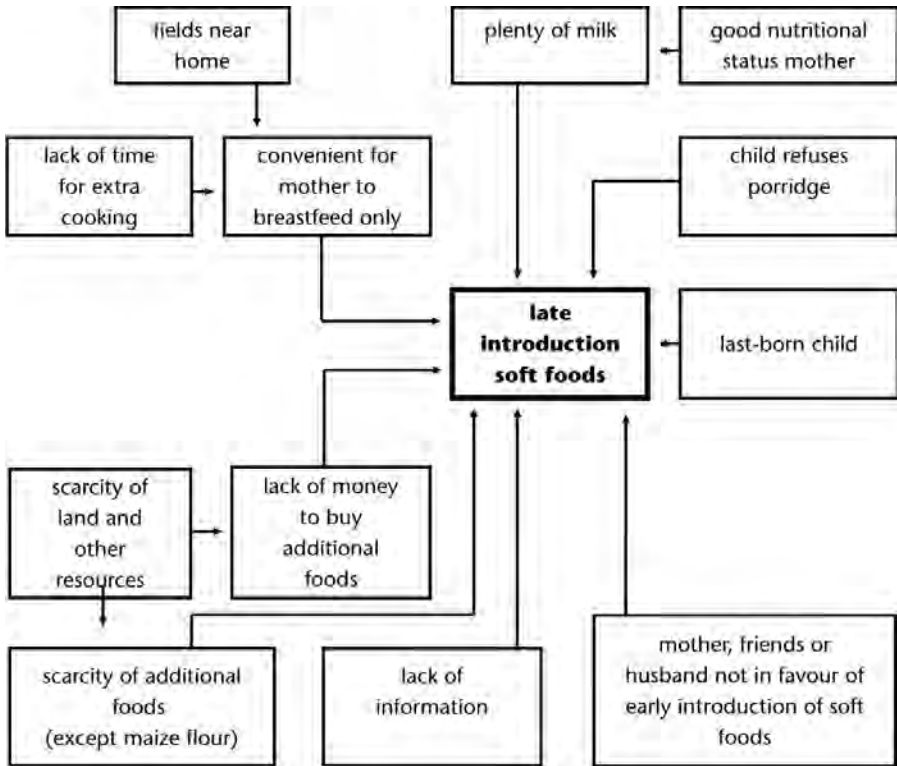

**Figure 36.3** Reasons for Late Introduction of Soft Foods by Young Mothers

Such diagrams can be prepared after one focus group discussion, for example, for young mothers as well as for mothers above child-bearing age. It will help to explore the problem even further in subsequent discussions. For example:

- *What influences whether mothers, friends or husbands are in favour or not in favour of the early introduction of soft weaning foods?*
- *How it is possible that some mothers have information on what soft foods to provide and how to prepare them, whereas other mothers lack this information?*
- *How could this information best be provided in health education?*

Some diagrams may be more complex than the ones presented here, especially if you include the attitudes and opinions of informants. You may change and elaborate the diagrams as you receive more data or proceed with the analysis of existing data.

### Flow Charts

Flow charts can be useful in tracing what happens after a certain action is taken. The figure below summarizes actions taken by mothers whose children have diarrhoea.

**Figure 36.4** Action Taken by 17 Mothers whose Breastfed Children (6-18 Months Old) had Severe Diarrhoea

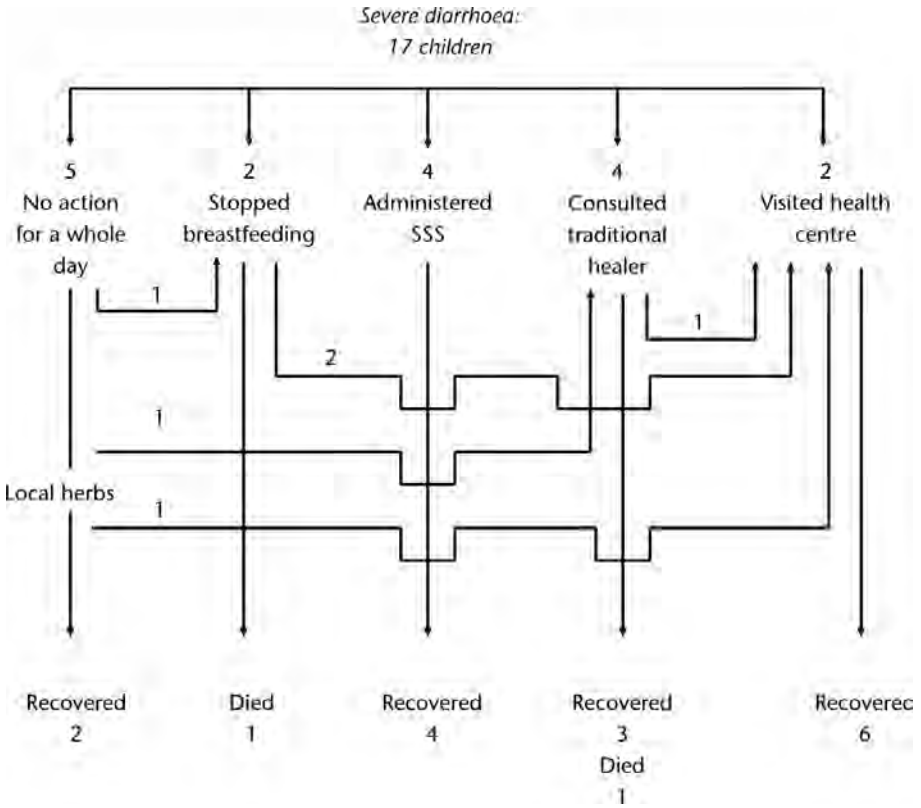

*From the flow chart we can see that different actions were taken by the 17 mothers who were interviewed. It is remarkable that those children who were given salt-sugar-solution (four in total) all recovered without any other form of treatment. Three mothers stopped breastfeeding their children, and one of these children died. The other two recovered after being taken to a health centre. Such information is important in making policy recommendations.*

Note: Remember that qualitative data needs to be contextualized. Not all the data can be reduced to tables and charts. You should therefore include other information in your write-up. It is always good to include direct quotations from informants, in the local language. This makes the discussion more clear and expressive.

### 3 Drawing and Verifying Conclusions

Drawing and verifying conclusions is the essence of data analysis. It is not an isolated activity, however. When we start summarizing our data, we continuously draw conclusions, and modify or reject quite a number of them as we proceed. Writing up the results of your study helps to generate new ideas as well. Therefore such writing should start as early as possible, right from the onset of data processing and analysis.

Keeping this in mind, let us briefly recapitulate the various possible steps in data processing and analysis that lead to the drawing of valid conclusions:

- Ordering the data in relation to the objectives/research questions.
- Categorizing or labelling answers that have similar characteristics or patterns.
- Displaying the summarized data in charts and figures such as matrices and diagrams or tables to help visualize possible relationships between certain variables.
- Identifying variables and associations between variables.

In analyzing your research data, you want to identify associations between variables.

*If we find that among the mothers who wean their children early, many are employed outside their homes, we can assume that having a job contributes to early weaning.*

- Context and finding confounding variables.

Variables sometimes appear to be related but the association cannot easily be explained. Other times it seems that variables should logically go together, but you cannot find a relationship. In cases such as these it may be that there is another variable influencing the association between the two variables concerned, that has to be identified.

*One example is the finding that some sanitation programmes were not able to determine the impact of the use of latrines on the incidence of diarrhoea. This was contrary to expectations. In the programme villages latrines were built but the incidence of diarrhoea was little effected by their implementation. The programme managers could not explain this discrepancy. Only through participant observation were they able to discover that villagers did not actually use the latrines as they found the smell repugnant and also claimed they attracted mosquitoes. Rules of courtesy disallowed this subject to be raised during village meetings.*

In this case, the behaviour of the villagers, i.e. their non-use of latrines, confounded the expected association between the use of latrines and the incidence of diarrhoea. Socio-cultural and behavioural factors often 'intervene' or 'confound' associations between variables. In qualitative research a preferred term for these factors is *contextual variables*. Since in social reality these contextual variables are always present, it is crucial that the research findings are always interpreted from the perspective of their wider socio-cultural context.

## 4 Strategies for Testing or Confirming Findings

Researchers who use quantitative research designs reduce their data to numbers and apply statistical tests. This does not necessarily ensure that their research results are valid: something may have gone wrong during sampling or collection of data. The following strategies therefore should be used by all researchers. They are particularly relevant, however, to qualitative research, as most of these strategies are used to establish logical coherence in the data collected.

- 1 Check for *representativeness* of data. Although the informants in qualitative research usually are not selected randomly, they must have been selected systematically, according to previously established rules. Check whether you have indeed interviewed all categories of informants needed to get a complete picture of your topic, e.g. different age groups of mothers. Also check back on focus group discussions – did you allow one or two participants to dominate the discussion? There is also a strong tendency, during field work, to note events that you find new and interesting. You can use such information but be sure to note if that observation can be generalized, i.e. was the activity you observed common or rare?
- 2 Check for bias due to *observer bias* or the influence of the researcher on the research situation. In qualitative research it is the researcher who is the major ‘research instrument’. Therefore it is particularly relevant that (s)he be aware of bias.
- 3 Cross-check data collected from interviews with observations, focus group discussions etcetera. A *multi-method approach*, also called triangulation, may help to improve the validity of the data.
- 4 Cross-check data with evidence from other, *independent sources*. These sources may be different research techniques employed to investigate the same topic, or results from other, similar studies. The data should confirm or at least not contradict each other. If there is contradiction, your data may still be valid if you can find explanations for the differences such as opposed interests between subgroups of your population. Do not try to ‘fit’ your findings with those of other studies. Scientific research constantly generates new information. Cross-checking data insures that you are not processing your data mechanically and that you are conscious about the need to assess validity of your research findings.

*If you have a research project on family planning, you might find that the answers of husbands and wives contradict each other. If the contradiction is in the type of family planning techniques used then you have to probe further. Perhaps your questions were not clear. It can also indicate that the method you used was insensitive: either the husband or wife felt you were asking too personal a question. But such inconsistency in your data does not necessarily imply that your findings are invalid. It may also reflect different perspectives between men and women on reproductive choice. One can expect differences in answers to questions such as ‘How many children would you like to have?’ In fact, a difference between the answers of*

*the husband and the wife can be important, for instance in case the husband's desired number of children is higher than that of the wife.*

- 5 *Compare and contrast data.* This can be built into the research design by including different categories of informants. If we want to be sure, for example, that variable A (high level of education) influences variable B (use of family planning methods) we have to compare a group of mothers with high education to a group of mothers with low education. Comparing and contrasting data is important if you are attempting to identify your variables as well as confirm associations between variables.
- 6 Use *extreme groups* of informants to the maximum. In the discussion of study design and sampling we stated that it may be useful to look for categories of informants that represent the extremes on a certain variable.

*You may find it most useful to study non-users of family planning services and regular attenders of these services, leaving out the category of irregular attenders. This may be the quickest way of identifying the key variables that influence the acceptance of contraceptive methods and preferences of (non)-users.*

- 7 Do *additional research* to test the findings of your study. You may have little time to do additional research, but the results of your study may be so intriguing that you decide to do a follow-up study afterwards. Such a study may be undertaken for several reasons:
  - to replicate certain findings;
  - to rule out (or identify) possible intervening variables;
  - to rule out rival explanations by investigating them; or
  - to look for negative evidence.

Additional studies undertaken for one or more of these reasons may serve to strengthen your conclusions in the original study.

- 8 Get *feedback* from your informants. We have stressed that you need to involve all parties concerned in the various stages of the research. It is important to get feedback on the research process itself, as well as on the data collected.

This is important not only for ethical reasons or because it will improve the chances that the results will be implemented, but also because it will improve the quality of your proposal, your data, and the conclusions drawn from these data. Suggestions and additional information collected during feedback sessions will invariably increase the quality of your research report, especially for applied purposes such as policy planning or programme evaluation.

## References

Miles, M.B. & A.M. Huberman

1984 *Qualitative Data Analysis: A Sourcebook of New Methods*. London: Sage Publications.

Spradley, J.P.

1979 *The Ethnographic Interview*. New York: Holt, Rinehart and Winston.

Walker, R. (ed.)

1985 *Applied Qualitative Research*. Hants: Gower Publishing Company Ltd.

Yin, R.K.

1984 *Case Study Research: Design and Methods*. London: Sage Publications.

---

## Exercise

Read the following article carefully.

Tomson, G. & G. Sterky

1986 'Self-Prescribing by Way of Pharmacies in Three Asian Developing Countries.' *The Lancet* September 13: 620-621.

*A Swedish researcher, Tomson, investigated the pattern of advice given and drugs dispensed at 75 Asian pharmacies in response to the presentation of a fictitious case of diarrhoea in an infant. In 75 pharmacies, he presented a fictitious case-history to the pharmacy attendant: 'I have a child of 11 months old with 3 days of diarrhoea. What treatment would you recommend?' The case-history was also typed in the prevalent local language and handed to the pharmacy attendant. Tomson concludes that only 16 of 75 pharmacies gave the appropriate advice – oral rehydration or consultation with a health worker.*

- 1 What are the data collection methods used by the researcher?
- 2 What are the problems with this research project? Some problems can be easily identified as being part of research design. What are these problems?

For example:

- What do you think of the validity of this research?
  - Could you identify possible sources of bias?
  - Could bias have been prevented?
  - Do you feel the authors have paid enough attention to ethical considerations?
- 3 What are the deficiencies in the analysis? How would you propose to improve on the project if you had to conduct it?
-





**MODULE 37**

**COMPUTER-ASSISTED  
QUALITATIVE DATA ANALYSIS**

# COMPUTER-ASSISTED QUALITATIVE DATA ANALYSIS

## Objectives

At the end of the Module the students should:

- be aware of the existence of Computer-Assisted Qualitative Data Analysis Software (CAQDAS);
- be able to mention the basic functions, advantages and disadvantages of CAQDAS;
- know where to find additional information on CAQDAS.

## Contents

- 1 Introduction
- 2 Functions of CAQDAS
- 3 Advantages and Disadvantages
- 4 Selected Websites

## 1 Introduction

Anthropological methods involve the collection of huge quantities of textual data. Traditionally the data is analyzed manually, as was explained in Module 36: data is ordered, coded, sorted, summarized, findings are verified and conclusions are made. However, with the advent of computer technology, Computer-Assisted Qualitative Data Analysis Software (CAQDAS) has become available which can support and facilitate certain steps involved in the processing of qualitative data. Although this computer assistance enables a researcher to do, for example, the tedious 'cut and paste' work faster and in a more convenient way, it should be stressed that the actual analysis and interpretation work still must be done by the researcher him/herself. The quality of the analysis of qualitative data does not depend on the use of a computer programme. It continues to be the researcher who determines all the steps in the analysis process and the quality of the outcome.

Today, a considerable number of software programmes are available for qualitative data analysis. Commonly used and cited programmes include AQUAD, Atlas.ti, Code-a-Text, Ethnograph, HyperResearch, Kwalitan, NUD\*IST, NVIVO, QED, and WinMaxpro. This Module does not aim to provide an overview of the advantages and disadvantages of each of these software programmes. However, at the end of the Module a list of websites has been included, where one can find more detailed information about some of these programmes. In most cases, a free demonstration programme can be downloaded which permits testing and comparison among the different software programmes.

Some of the programmes can also aid the analysis of illustrations, sound and video images. This module addresses only text analysis.

## 2 Functions of CAQDAS

Most programmes can be used with all kinds of written text, such as transcribed interviews, fieldwork notes, documents or any other text that can be entered into a word processor. This includes a text that has been downloaded from the internet. In some cases, the text must be prepared before it can be 'read and understood' by the CAQDAS.

Most of the above mentioned programmes contain functions which aid the researcher in the following steps of data analysis:

### 1 *Organizing*

Using computer software allows the storage of various documents (transcribed interviews, fieldnotes and documents) in separate work files or databases, while still offering the possibility to search different files simultaneously using one or more codes.

### 2 *Coding*

Coding may be done manually, automatically or both. The number of codes that can be attached to parts of the texts differ per programme, as well as the length of

the parts (word, one or more paragraphs) to which codes can be attached. Sometimes these parts can overlap. Some programmes can give subcodes (*nesting*) or enable the codes to be related hierarchically.

### 3 *Searching and Retrieving*

After the data has been entered and coded, all CAQDAS have the important characteristic of being able to search for parts of text that have been given a certain code. This is probably the most time-saving characteristic of using CAQDAS, especially when a lot of data is involved. Instead of reviewing all the documents to find the segments containing a certain code, the software can retrieve and print all the relevant text parts at 'a push of a button'. Some programmes include the so-called KWIC (*keyword in context*) view option which provides information on the context of the searched word or code.

### 4 *Making Memos*

The researchers' comments, reflections or temporary definitions of codes or used concepts can – often – be jotted down in separate memory files (*memos*), and in some cases these files are connected to a part of the text and/or a code. This allows the researcher to keep detailed track of the way he or she has gone through the process of analysis.

In some CAQDAS it is possible to write in the original text, for example, to correct errors or add comments. In other programmes the text is to be 'read only'. A number of software programmes also can handle the data in a quantitative way. Some of the programmes are based on a theoretical orientation in qualitative data analysis, as for example, the *grounded theory*.

## 3 *Advantages and Disadvantages*

After the data has been entered and coded, computer-supported sorting and retrieving makes the work easier and faster. However, one should not forget that entering and coding the data are time-consuming activities themselves, especially if you still have to learn to use the programme after the data has already been collected. Whether or not software will save time in a particular situation depends on several factors, such as personal computer experience and skills, the amount of data collected, and the kind and depth of analysis to be applied. For any potential future user of a CAQDAS it may be wise to first experiment with a programme or a demonstration programme using a limited amount of data. Afterwards one can decide on the value or added value of using the software. Asking someone who is actually using the programme to give a short demonstration may be a good way of gaining insight on its advantages and disadvantages.

One of CAQDAS's important features is the structuring of data management. This also allows more researchers to work together on one project, and even, on the same material. This may enhance the validity of the analysis and one can even think of replica-

tion of the analysis process. It even seems that computer software increases the credibility and acceptance of qualitative research within the scientific community. One should, however, be careful not to overestimate the added value of using qualitative software for analysis of qualitative data. The tool in itself cannot determine quality.

When using computer software to analyse qualitative data it is crucial that the researcher does not allow the text's real essence to be lost, and the analysis to become mechanical. Ethnographers and other qualitative researchers 'dive deep' into their data to look for meanings and relationships. The 'traditional' reading, re-reading and scanning of the entire, transcribed interviews should not be bypassed when using computer software. One should be careful not to decontextualize findings.

Another problem involving software and the processing of textual data, occurs when data is recorded and transcribed in a local language. In such cases, the computer programme requires translation of this data into English or another language understood by the computer and this information must then be entered into the programme again. This extra step may result in the loss of valuable insights attainable only in the local language.

### Selected Websites

ATLAS.ti	<a href="http://www.atlasti.de">www.atlasti.de</a>
ETHNOGRAPH	<a href="http://www.QualisResearch.com">www.QualisResearch.com</a>
HyperRESEARCH	<a href="http://www.researchware.com">www.researchware.com</a>
KWALITAN	<a href="http://www.kwalitan.net">www.kwalitan.net</a>

## References

Alexa, M. & C. Zuell

- 1999 Review of software for text analysis. Spezial Band 5. ZUMA, Mannheim ([www.zuma-mannheim.de](http://www.zuma-mannheim.de)).

Fielding, N. & R. Lee (eds.)

- 1991 *Using computers in qualitative research*. Thousands Oaks, Sage Publications.

Fielding, N.

- 1993 Analysing qualitative data by computer. Social Research Update, issue one. ([www.soc.surrey.ac.uk/sru/SRU1.html](http://www.soc.surrey.ac.uk/sru/SRU1.html)).

Nigel G., N. Fielding & R. Lee

- 1998 *Computer analysis and qualitative research*. London: Sage Publications.

Weitzman, E. & M. Miles

- 1995 *Computer programs for qualitative data analysis. A software sourcebook*. Thousands Oaks, CA: Sage.

**ANALYSIS OF QUANTITATIVE DATA**

# ANALYSIS OF QUANTITATIVE DATA

## Objectives

At the end of this Module, the participants should be able to:

- construct cross-tabulations that will help meet their research objectives;
- identify possible confounding variables that need consideration when exploring relationships between variables, and take appropriate measures to deal with them.

## Contents

- 1 Introduction
- 2 Different Types of Cross-Tabulations
- 3 Constructing Cross-Tabulations Appropriate for the Research Objectives
- 4 General Hints When Constructing Tables
- 5 Dealing with Confounding Variables: Stratification and Matching

\* Adapted from Module 23, Health Systems Research Training Series, Volume 2



## 1 Introduction

Thus far we have made tables containing frequency distributions for one variable at a time to partially describe our data. Depending on the objectives of our study and the study type, we may have to examine the relationship between several of our variables at once in order to adequately describe our problem or identify possible explanations for it.

For this purpose it is appropriate to design *cross-tabulations*.

*We want to know the ages at which teenage pregnancies occur and whether they are more frequent among school girls than among girls who are not attending school. To answer these questions we may construct the following cross-tabulation (the data are imaginary):*

**Table 38.1** Number of Teenage Pregnancies at Different Ages among Girls Attending School and Not Attending School (Province X, 1988-1990)

Age at onset of pregnancy	Number of pregnancies		Total
	Attending school	Not attending school	
12 years	2 (3%)	1 (2%)	3
13 years	2 (3%)	0	2
14 years	5 (7%)	2 (4%)	7
15 years	23 (34%)	12 (23%)	35
16 years	36 (53%)	37 (71%)	73
Total	68 (100%)	52 (100%)	120

Some examples of cross-tabulation tables are provided in the following pages. You will notice that in each example the nature and the design of the cross-tabulation table is determined by the objectives and the type of study conducted.

## 2 Different Types of Cross-Tabulations

Depending on the objectives and the type of study, three different kinds of cross-tabulations may be required:

- Cross-tabulations may aim at describing the problem under study by presenting a combination of variables. Table 38.1 is an example. Cross-tabulations are also used to describe a sample of research subjects in terms of a combination of contextual variables, such as age, sex, profession, residence.
- Cross-tabulations in which groups are compared to determine differences.
- Cross-tabulations that focus on exploring relationships between variables.

Examples of each of these three types of cross-tabulations are given below.

### *Cross-Tabulations to Describe a Sample*

In any study which yields quantitative data, whether descriptive or comparative, it is common to first describe the research subjects included in the sample(s) before presenting the actual results of the study. This can be done for separate variables in a simple frequency table or for a combination of variables in a cross-tabulation.

*A study was carried out on the degree of job satisfaction (dependent variable) among doctors and nurses in rural and urban areas. To describe the sample a cross-tabulation was constructed which included the sex and the residence (rural or urban) of the doctors and nurses interviewed. This was useful because in the analysis the opinions of male and female staff had to be compared separately for rural and urban areas.*

**Table 38.2** Residence and Sex of Doctors and Nurses

Health workers		Residence		Total
		Rural	Urban	
Doctors	Males	8 (10%)	35 (21%)	43
	Females	2 (3%)	16 (10%)	18
Nurses	Males	46 (58%)	36 (22%)	82
	Females	23 (29%)	77 (47%)	100
Total		79 (100%)	164 (100%)	243

*Table 38.2 can also be split up into two separate cross-tabulations for residence and type of health workers: one for males and one for females.*

The data in the tables is usually listed in absolute figures as well as in relative frequencies (percentages or proportions). For numerical data (such as age) the mean, median and/or mode may be calculated as well to describe the sample.

In descriptive studies that aim at quantification of a certain problem, cross tabulation is a useful tool for presenting findings.

### *Cross-Tabulations to Determine Differences between Groups*

In comparative studies such as case-control studies, cohort studies or intervention studies, some objectives will focus on discovering whether any differences exist between two or more groups on particular variables. In such cases cross-tabulation of data is necessary.

*In a intervention study of the effect of attendance of mothers at nutrition talks on their level of nutritional knowledge two groups of mothers were compared: those who did and those who did not attend the nutrition talks. The following dummy cross-tabulation table was prepared:*

**Table 38.3** Number of Attenders and Non-Attenders at Nutrition Talks with Different Levels of Nutritional Knowledge

	Level of nutritional knowledge			Total
	Low	Average	High	
Attenders				
Non-attenders				
Total				

*In this example ‘low’, ‘average’ and ‘high’ level of nutritional knowledge have to be clearly defined.*

Note that in the above cross-tabulation the groups that are to be compared are put in rows, whereas the different levels of nutritional knowledge are put in columns. This is because ‘nutritional knowledge’ is the outcome of the attendance at nutrition talks and it is therefore considered to be the dependent variable.

It is the accepted convention to place the categories of the *dependent* variable in *columns*. The categories of the *independent* variable is displayed in *rows*.

*In a case-control study on malnutrition, severely malnourished children (cases) were compared with well-nourished children (controls) in order to find appropriate ways of alleviating the problem of malnutrition in children. The following dummy cross-tabulation was constructed:*

**Table 38.4** Level of Mothers’ Nutritional Knowledge for Mothers with Severely Malnourished and Well-Nourished Children (12-35 Months)

Level of mothers’ nutritional knowledge	Nutritional status of their children		Total
	Severely malnourished (cases)	Well-nourished (controls)	
Low			
Average			
High			
Total	100%	100%	

Note the difference between Tables 38.3 and 38.4. In Table 38.4 ‘nutritional knowledge’ is the independent variable, and thus is displayed in the rows, whereas the two groups which are to be compared are displayed in the columns.

Yet other cross-tabulations can be constructed to be used in the study mentioned above. Each time the two groups (severely malnourished children and well-nourished children) can be displayed in the columns. Different independent variables can be put in rows, such as source of drinking water (protected or unprotected) or immunization status (fully immunized or not).

When constructing cross-tabulations to detect differences between groups, carefully decide whether the groups that are to be compared should be put in rows or in columns, depending on the type of study.

When calculating percentages to be put in the cross-tabulation it is important to remember that the totals for each of the groups which are to be compared should be 100%.

Once these cross-tabulations are filled in with the appropriate data they can be used when performing statistical tests.

*Cross-Tabulations to Explore Relationships between Variables*

Many Applied Health Research projects aim at exploring possible relationships or associations among variables. In such cases it is important to consider whether the variables are independent or dependent.

*In a study of breastfeeding practices you may examine the relationship between the age of mothers and duration of breastfeeding. The cross-tabulation presented in Table 38.5 could be helpful.*

**Table 38.5** Duration of Breastfeeding in Mothers of Different Age Groups

Age (years)	Duration of breastfeeding			Total
	0-5 months	6-11 months	12 months	
15-19				
20-24				
25-29				
30-34				
35-39				
40				
Total				

*If you want to determine whether there is an association between the working status of mothers (independent) and the duration of breastfeeding (dependent variable) Table 38.6 would be appropriate.*

**Table 38.6** Duration of Breastfeeding in Relation to Working Status of Mother

Mothers' working status	Duration of breastfeeding			Total
	0-5 months	6-11 months	12 months	
Full-time employed				
Part-time employed				
Not employed				
Total				

### 3 Constructing Cross-Tabulations Appropriate for the Research Objectives

When designing your research project you were asked to produce dummy tables for the data you expected to collect. These dummy tables were made on the basis of the objectives and the type of study.

After you have collected your data and have an idea of their quality and how they can be used, you need to look again in a systematic way at the cross-tabulations to be made.

To construct appropriate cross-tabulations we recommend that you follow the steps below:

- 1 Review each specific objective and the method chosen for collecting the relevant data.
- 2 Formulate hypothetical sentences that you consider to be the type of conclusions you expect to reach concerning each objective.

*In a study on breastfeeding practices, where one of the specific objectives is to determine factors associated with early weaning expected conclusions could be:*

- *‘Mothers who are employed wean their children earlier than mothers who are not employed.’*
- *‘Mothers who did not attend nutrition talks wean their children earlier than mothers who attended nutrition talks.’*

The reasons for formulating ‘possible conclusions’ are that they help you:

- remember the purpose of each tabulation and calculation you undertake;
- avoid wasting time on meaningless calculations and tabulations; and
- keep your data organized so you can more easily write a well-organized report.

- 3 For each ‘possible’ or ‘expected conclusion’ construct the dummy cross-tabulations that will enable you to derive the right conclusions.
- 4 Perform the appropriate frequency counts (using the data mastersheets) and enter the results in the cells of the cross-tabulation.
- 5 Interpret the table and write a clear conclusion. It is not necessary to describe the content of the table in detail.

### 4 General Hints when Constructing Tables

- Make sure that all the categories of the variables presented in the tables have been specified and that they are mutually exclusive (i.e. no overlaps and no gaps).
- When making cross-tabulations check that the column and row counts correspond to the frequency counts for each variable.
- Also check that the grand total in the table corresponds to the number of subjects in the sample.

- Think of a clear title for each table. Also be sure that the headings of rows and columns leave no room for misinterpretation.
- Number your tables and keep them together with the objectives to which they are related. This will assist in organizing your report and ensure that work is not duplicated.

## 5 Dealing with Confounding Variables: Stratification and Matching

### *Stratification*

If one or more of the objectives of your study focus on exploring relationships among variables it is important to determine whether there are other factors which influence these relationships. These are known as intervening or confounding variables.

*In the example of the relationship between breastfeeding and working status it might be that the educational level of the mother is such a confounding variable, as it could be related to both the working status of the mother and duration of breastfeeding.*

Once you have collected your data the appropriate way of dealing with confounding variables is *stratification*, which involves a separate analysis for the different levels of this confounding variable.

*Such a separate analysis involves the construction of cross-tabulations for mothers with different educational levels. This means that Table 38.6 has to be split up into two tables: one for those mothers who have little schooling, say less than 5 years, and another one for those who have 5 or more years of schooling.*

If we find a similar association between working status and duration of breastfeeding in both groups of mothers, then this indicates that the educational level of the mother is *not* a confounding variable.

### *Matching*

In the Module on variables and validity (Module 16) it was stated that if at the stage of designing the study a variable is already suspected to be a confounding variable, the effect of this variable may be removed by pairing the observations (also called *matching*). In this procedure each subject in the study group is matched with another subject in the control group for the particular confounding variable.

*For each employed mother with less than 5 years of schooling you would choose a non-employed mother with a similar educational level. Also for each employed mother with 5 or more years of schooling you would select a non-employed mother with 5 or more years of schooling.*

---

## Assignment

- 1 Review each specific objective and formulate hypothetical sentences that describe the type of conclusions you expect for each objective.
  - 2 Construct dummy cross-tabulations, keeping in mind whether you want to:
    - describe research subjects in your sample or describe the problem;
    - compare groups in order to find differences; or
    - find associations between variables.
  - 3 If you construct analytic cross-tabulations, try to identify possible confounding variables by making further dummy cross-tabulations (stratification).
  - 4 Finally, fill in the dummy cross-tabulations with data and formulate a conclusion after completion of each table.
-





**MODULE 39**

**WORK PLAN**

# WORK PLAN

## Objectives

At the end of this Module, the participants should be able to:

- describe the characteristics and purposes of various project planning and scheduling techniques such as work scheduling and GANTT charting;
- determine the staff they need for the various tasks in their project and describe why they need additional staff (research assistants, data collectors, or supervisors) apart from the research team that developed the proposal, where they will recruit them, for how long a period they need them, and how they will train and supervise them;
- prepare a work schedule, GANTT chart, and staffing plan for the project proposal they are developing.

## Contents

- 1 Introduction
- 2 Various Work Scheduling and Planning Techniques
- 3 The Use of a Work Plan

\* Adapted from Module 15, Health Systems Research Training Series, Volume 2

## 1 Introduction

What is a work plan?

---

A **WORK PLAN** is a schedule, chart, or graph that summarizes, in a clear fashion, various components of a research project and how they fit together.

---

It may include:

- the tasks to be performed;
- when the tasks will be performed; and
- who will perform the tasks and the time each person will spend on them.

## 2 Various Work Scheduling and Planning Techniques

### 1 *The Work Schedule*

---

A **WORK SCHEDULE** is a table that summarizes the tasks to be performed in a research project, the duration of each activity, and the staff responsible.

---

The version of a work schedule given on the following page includes:

- the tasks to be performed;
- the dates each task should begin and be completed;
- research team, research assistants, and support staff (drivers and typists) assigned to the tasks; and
- person-days required by research team members, research assistants, and support staff (the number of person-days equals the number of working days per person).

The period for field research for a project should not exceed 6 months.

This work schedule was developed for a study of factors contributing to low utilization of family planning services in a certain region. The research team consisted of four persons (mainly regional health team members).

The study consisted of two main parts:

- 1 Analysis of the service records to assess the percentage of the users of the services and the regularity of their attendance, and interviews with staff responsible for the service delivery.
- 2 Interviews with female users and non-users of the family planning services (sampled from the records); and interviews with husbands of female users and of non-users of FP services.

**Table 39.1** Example of a Work Schedule: Family Planning Study (FP)

<i>Tasks to be performed</i>	<i>Dates</i>	<i>Personnel assigned to task</i>	<i>Person days required</i>
1 Finalize research proposal and literature review	week 1 - 3 4 - 24 April	Research Team (4)	4 x 3 = 12 days
2 Clearance from national and funding authorities	week 1 - 5 4 Apr. - 8 May	Research unit - Ministry of Health	
3 Clearance and orientation of local authorities	week 6 9 -15 May	PI (Regional Health Officer) Driver	2 days 2 days
4 Compilation of family planning records and interviews of FP staff	week 6 - 9 9 May - 5 June	Public health nurse Driver	10 days 10 days
5 Analysis of FP records and sampling study units	week 10 6 - 12 June	Research team Secretary	4 x 2 = 8 days 1 day
6 Training of research assistants and field testing questionnaire	week 11 13 - 19 June	Research team Research assistant(s) Facilitator	4 x 3 = 12 days 5 x 3 = 15 days 1 x 4 = 4 days
7 Interviews in community	week 12 -13 20 June - 3 July	Research team Research assistants	4 x 10 = 40 days 5 x 10 = 50 days
8 Preliminary data analysis	week 19 -22 8 - 28 Aug.	Research team Research assistants Facilitator	4 x 7 = 28 days 5 x 1 = 5 days 1 x 2 = 2 days
9 Feedback to local authorities and district health teams	week 27 3 - 9 Oct.	Research team Driver	4 x 1 = 4 days 2 days
10 Feedback to communities	week 28 10 - 16 Oct.	Research team Driver	4 x 1 = 4 days 1 day
11 Data analysis and reporting workshop	week 29 -30 17 - 30 Oct.	Research team Facilitator	4 x 10 = 40 days 1 x 10 = 10 days
12 Report finalization	week 31 - 34 31 Oct. - 28 Nov.	Research team Secretary	4 x 2 = 8 days 1 x 5 = 5 days
13 Discussion of recommendations /plan of action with local authorities and district health teams	week 36 - 37 12 - 25 Dec.	Research team Secretary Driver	4 x 3 = 12 days 3 days 3 days
14 Monitoring research project	continuous	Research team	4 x 1 = 4 days

You will notice that, if the workshops are excluded, each team member roughly spent 30 working days on the research, except the regional public health nurse. She visited all centres with FP services in the region to analyze the records and interview staff. Although she integrated these tasks with her normal supervisory duties, she spent about 10 working days more than the other team members. Five research assistants (two community health nurses and three district health Inspectors) were recruited to assist with the interviewing. The number of working days required was multiplied by four (for the research team) and five (for the research assistants) to arrive at the number of person-days.

### *How to Develop a Work Schedule*

- a Review and revise, if necessary, the list of tasks you prepared for your plan for data collection (Module 21). Add to the list other tasks you must complete not related to data collection (such as clearance of proposal; data analysis and report writing; and feedback to authorities and target group). Number all tasks.
- b Now review the staffing for the different tasks, taking into account your experience during the pretest. Consider:
  - who will carry out which tasks;
  - the amount of time needed per research unit (interview/observation/record) including travel time; and
  - the number of staff needed to complete each task in the planned period of time.
 Make revisions, if required. Complete the staffing for the tasks you have just added.
- c Consider whether the use of short-term consultants is necessary for certain tasks. Always consider using local consultants. If consultants are used, involve them in the planning stage of the project so you can incorporate any useful suggestions they may have concerning the design of the methodology.
- d In reviewing your tentative staffing plan you should ask:
  - Are the types of personnel and levels of expertise you require likely to be available for the project? For example, is there a sufficient range of disciplines available including, where appropriate, personnel from outside the health field?
  - If special staff have to be recruited or reassigned from other ministries or agencies, what regulations or procedures will have to be followed?
  - Is the staffing plan realistic, taking into account the project budget that is likely to be available?
  - To what extent can community members, traditional healers, students, or other non-professionals be involved in the study?
  - What training would the research assistants or data collectors require? How long would the training last? Who would do the training? How do you intend to supervise the assistants and data collectors?

Then fix the dates (in weeks) indicating the period in which each task will have to be carried out and calculate the number of working days per person required to complete each task.



## 2 *The GANTT Chart*

---

The GANTT CHART is a planning tool which depicts graphically the order in which various tasks must be completed and the duration of each activity.

---

The GANTT chart shown on the following page indicates:

- the tasks to be performed;
- who is responsible for each task; and
- the time each task is expected to take.

**The length of each task is shown by a bar that extends over the number of days, weeks or months the task is expected to take.**

## 3 The Use of a Work Plan

A work plan can serve as:

- a tool in planning the details of the project activities and later in budgeting funds;
- a visual outline or illustration of the sequence of project operations. It can facilitate presentations and negotiations concerning the project with government authorities and other funding agencies;
- a management tool for the principal investigator and members of his or her team, showing what tasks and activities are planned, their timing, and when various staff members will be involved in various tasks;
- a tool for monitoring and evaluation, when the current status of the project is compared to what had been foreseen in the work plan.

When should the work plan be prepared?

- The first draft of the work plan should be prepared when the project proposal is being developed, so the schedule can be discussed easily with the relevant authorities.
- A more detailed work plan should be prepared after the pretest in the study area.
- There should be no hesitation in revising work plans or preparing new ones after the project is underway based on a reassessment of what can be realistically accomplished in the coming months.

The factors that should be kept in mind when preparing a work plan are:

- It should be simple, realistic, and easily understood by those directly involved.
- It should cover the preparatory and the implementation phases of the project, as well as data analysis, reporting, and dissemination/utilization of results.
- The activities covered should include technical or research tasks; administrative, secretarial, and other support tasks; and training tasks.
- The realities of local customs (local holidays, festivals) and working hours should be considered when preparing the work plan.

- Also seasonal changes and their effect on travel, work habits, and on the topic you are studying (such as incidence of disease or nutritional status) should be kept in mind as the schedule is planned.
- 

## Assignment

Prepare a work plan for inclusion in your proposal, following the steps described below:

- 1 Start with the development of a work schedule:
    - List all tasks to be carried out, completing and revising the list of tasks you prepared for your plan for data collection.
    - Consider who will carry out each task; the number of working days required per person to complete each task; the number of staff you will need to finish each task in a given period of time; and the period in which you plan to actually carry out each task.
    - Consult a calendar and note any public holidays or other important activities scheduled for the research period (about 6 months) in which you plan to conduct the fieldwork.
    - Do not forget to include support staff required (typists, drivers, etc.) and facilitators or local consultants.
  - 2 Consider whether the number of days each member of the research team plans to spend in the field is acceptable (generally it should not exceed 30 working days).
  - 3 Prepare a GANTT chart to include in your proposal.
  - 4 Include two or three paragraphs on the staff required for your research and their tasks in your work plan. Include:
    - the composition of the research team itself and the tasks of its various members;
    - the reasons for recruiting research assistants / data collectors / supervisors; where you recruit them; what their tasks will be; for how long they are required; how you will train and supervise them;
    - the role of facilitators during the fieldwork and when they will be needed;
    - whether any other consultants will be needed and, if so, what skills they should have and what their tasks would be.
-



**MODULE 40**

**BUDGET**

# BUDGET

## Objectives

At the end of this Module, the participants should be able to:

- select or develop appropriate major categories for a budget;
- make reasonable estimates of the expenses in various budget categories;
- list various ways a budget can be reduced, if necessary, without substantially damaging a project;
- prepare a realistic and appropriate budget for the project proposal being developed during the course.

## Contents

- 1 The Importance of Budget Preparation
- 2 The Preparation of a Budget
- 3 The Budget Format and Justification
- 4 Obtaining Funding for Projects

Annex 40.1 Example of Budget for a Family Planning Study (in Kwachas)

Annex 40.2 International Sources of Funding for Research

## 1 The Importance of Budget Preparation

There are several reasons why we need a budget:

- A detailed budget will help you to identify which resources are already locally available and which additional resources may be required.
- The process of budget design will encourage you to consider aspects of the work plan you have not thought about before and will serve as a useful reminder of activities planned, as your research gets underway.

When Should Budget Preparation Begin?

A complete budget is normally not prepared until the final stage of project planning. However, cost is usually a major limiting factor and, therefore, must always be kept in mind during planning so that your proposals will not require an unrealistically high budget. Remember that both ministries and donor agencies usually set limits for research project budgets.

The use of locally available resources increases the feasibility of the project from a financial point of view.

## 2 The Preparation of a Budget

It is convenient to use the work plan as a starting point. Specify, for each activity in the work plan, what resources are required. Determine for each resource needed the *unit cost* and the *total cost*.

---

The UNIT COST (e.g. per diem or cost of petrol per km), the MULTIPLYING FACTOR (number of days), and TOTAL COST should always be clearly indicated for all budget categories.

---

*In the work plan of a study to determine the utilization of family planning methods in a certain district, it is specified that 5 interviewers will each visit 20 households in clusters of 4 over a time period of 5 working days. A supervisor will accompany one of the interviewers each day using a car. The other 4 interviewers will use motor cycles. The clusters of households are scattered over the district but are on average 50 kilometres from the district hospital from where the study is conducted.*

The budget for the field work component of the work plan will include funds for personnel, transport and supplies. In Table 40.1 an example of a budget of costs involved in fieldwork for a family planning study.

If more than one budget source will be used (e.g. the Ministry of Health and a donor), it would be useful to indicate in the budget which source will pay for each cost. Usually a separate column is used for each funding source (see Annex 40.1).

**Table 40.1** Costs Involved in Fieldwork for a Family-Planning Study

<i>Budget category</i>		<i>Unit cost</i>	<i>Multiplying factor</i>	<i>Total cost</i>
1	Personnel	Daily wage (including per diem)	Number of staff-days (no. staff x no. of working days)	Total
	Interviewers	\$ 10	5 x 5 = 25	\$ 250
	Supervisor	\$ 20	1 x 5 = 5	\$ 100
			Personnel TOTAL	\$ 350
2	Transport	Cost per km	Number of km (no. vehicles x no. days x no. km/day)	Total
	Motorcycles	\$ 0.10	4 x 5 x 100 = 2000	\$ 200
	Car	\$ 0.40	1 x 5 x 100 = 500	\$ 200
			Transport TOTAL	\$ 400
3	Supplies	Cost per item	Number	Total
	Pens	\$ 1.00	12	\$ 12
	Questionnaires	\$ 0.20	120	\$ 24
			Supplies TOTAL	\$ 36
			Grand TOTAL	\$ 786

### 3 The Budget Format and Justification

An example of a project budget is provided in Annex 40.1. This budget includes the major categories that are usually needed for small projects: personnel, transport, and supplies and equipment.

The type of budget format to be used may vary depending upon whether the budget will be supported by your own organization or the ministry of health or submitted to a donor organization for funding. Most donor organizations have their own special project forms, which include a budget format.

If you intend to seek donor support it is advisable to write to the potential funding organization as early as possible during the period of project development.

#### *Advice on Budget Preparation*

- Keep in mind the tendency to underestimate the time needed to complete project tasks in ‘the real world’. Include a 5% contingency fund if you fear that you might have budgeted for the activities rather conservatively (if inclusion of a contingency fund is not allowed, an alternative is to slightly over-budget in major categories).

- Do not box yourself in too tightly with very detailed categories and amounts, especially if regulations do not allow adjustments afterward. Ask the supervising agency to agree that there may be some transfer between ‘line items’ in the budget, if needed.
- If your government or department has agreed to contribute a certain amount for the project, try to arrange that the contribution be administered separately, so that the administrators remain aware of the commitment. This may also ensure easier access to the funds.
- If the budget is for a period longer than a year, build in allowances for inflation before the project begins and in subsequent years by increasing costs by a set percentage (if inflation is high in the local economy, you may have to build in allowances for even shorter projects).

It is not sufficient to present a budget without explanation. The *budget justification* follows the budget as an explanatory note justifying briefly, in the context of the proposal, why the various items in the budget are required. Make sure you give clear explanations concerning why items that may seem questionable or are particularly costly are needed and discuss how complicated expenses have been calculated. If a strong budget justification has been prepared, it is less likely that essential items will be cut during proposal review.

#### *How Can Budgets Be Reduced?*

- Explore whether other health-related institutions are willing to temporarily allocate personnel to the project.
- When possible, use local rather than outside personnel. If consultants are needed at the beginning, train local personnel as soon as possible to take over their work.
- Explore the use of students or community volunteers, where appropriate.
- Plan for strict control of project expenditures, such as those for vehicle use, supplies, etc.

## 4 Obtaining Funding for Projects

To conduct research, it is usually necessary to obtain additional funding for the research project. Such funding may be available from local, national, or international agencies. In addition to preparing a good research proposal, the following strategies are useful for researchers who need to obtain their own funding:

- 1 Familiarize yourself with the policies and priorities of funding agencies. Such policies and priorities may be:
  - *explicit*, i.e. available from policy documents issued by the agency;
  - *implicit*, i.e. known to officials in the agency and to other local researchers who have previously been funded by that agency.

Obtain the names of such persons and make direct contact with them. The funding policies of many agencies may emphasize:

- priority for research aimed at strengthening a particular program (e.g. MCH, PHC);
- institution building (i.e. building the capacity of an institution to do research);
- research credibility.

Annex 40.2 gives a list of some prominent research funding agencies.

- 2 Identify the procedures, deadlines, and formats that are relevant to each agency.
  - 3 Obtain written approval and support from relevant local and national health authorities and submit this together with your proposal.
  - 4 If you are a beginning researcher, associate yourself with an established researcher. Host agencies scrutinize the ‘credibility’ of the researcher to whom funds are allocated. Such credibility is based on previous projects that have been successfully completed.
  - 5 Build up your own list of successfully completed projects (i.e. your own reports, publications, etc.).
- 

## Assignment

- 1 Prepare a budget for your project. Keep in mind the importance of having a realistic budget for which resources can actually be found (see Annex 40.1 for an example).
  - 2 Examine the work plan in your project proposal and consider the expenses involved in completing each component. Local rules should be followed for calculating per diems, travel cost, and overtime (if required).
  - 3 Indicate for each item, the unit cost as well as the number of units. Justify large budget items, travel, and allowances in one or two paragraphs attached to the budget.
  - 4 Consider the cost-effectiveness of various budget levels. Will the final results be worth the expense?
  - 5 Consider the budget level that possible funding authorities would consider appropriate:
    - Examine their guidelines.
    - If appropriate, talk with donor representatives about their policies.
  - 6 If additional funding is requested from an outside donor, make clear what contribution the ministry of health and your own institution are making.
-

**Annex 40.1 Example of Budget for a Family Planning Study (in Kwachas)**

<b>1. Personnel costs</b> <i>(excluding workshops)</i>	<b>Ministry of health</b>	<b>Donor</b>	<b>Total</b>
<i>Research team</i>	<i>Salary</i>		
88 person-days in provincial capital	"	2,520	2,520
56 person-days in field per diem 56 x K 45			
<i>Research assistants</i>			
20 person-days in provincial capital per diem 20 x K 45	"	900	900
50 person-days in field per diem 50 x K 45	"	1,750	1,750
<i>Facilitator</i>			
6 person-days in provincial capital per diem 6 x K 12		720	720
per diem driver 6 x K 35		210	210
<i>Drivers of project</i>			
18 person-days per diem 10 x K 35	"	630	630
<i>Secretary</i>			
8 person-days	"		
<i>2 seniors of each of the 5 district hospitals</i>			
11 person-days in provincial capital per diem 11 x K 70	"	770	770
<i>2 senior officials MOH</i>	"		
4 person-days in provincial capital per diem 4 x K 70		280	280
driver per diem 2 x K 35		70	70
<b>SUBTOTAL</b>	<b>4630</b>	<b>7,850</b>	<b>12,480</b>

<b>2 Transport costs</b>	<b>MOH</b>	<b>Donor</b>	<b>Total</b>
Clearance local leaders (340 km)			
Compilation FP records			
staff interviews (21 clinics) (2100 km)			
Training research			
assistants and field test (100 km)			
Data collection in 2 districts (1400 km)			
Discussion District Health Teams and HQ			
authorities (1540 km)			
Facilitators' visits (2880 km)			
TOTAL MILEAGE (8360 km)			
8360 x K 0.35/km for petrol		2,926	2,926
8360 x K 1/km for operating costs	8,360		8,360
Public transport for research assistants		210	210
2 return air tickets for senior MOH staff		450	450
SUBTOTAL	8,360	3,586	11,946

<b>3 Supplies</b>	<b>MOH</b>	<b>Donor</b>	<b>Total</b>
12 reams duplicating paper x K 37.50	450		
1 ream writing paper	50		
1 ream photocopy paper	70		
20 folders x K 5	100		
5 writing pads x K 8	40		
Pens, rubbers, etc.	60		
4 boxes stencils x 4.50	200		
5 tubes duplicating ink	110		
SUBTOTAL	1,080		1,080



<b>Summary</b>	<b>MOH</b>	<b>Donor</b>	<b>Total</b>
Personnel costs			
Transport costs	4,630	7,850	
Stationery	8,360	3,586	
		1,080	
		12,480	
		11,946	
		1,080	
TOTAL (Kwachas)	12,990	12,516	25,506
5% contingency	650	626	1,275
GRAND TOTAL in Kwachas	13,640	13,142	26,781
GRAND TOTAL in US\$ *	5,683	5,476	11,159

\* Exchange rate 1 US\$ = K 2.40

## Annex 40.2 International Sources of Funding for Research

### 1 *International Multi-Lateral Agencies*

WHO and associated special programmes:

WHO	Regional Offices
WHO	Headquarters
TDR	(Tropical Disease Research)
CDD	(Control of Diarrhoeal Disease)
HRP	(Human Reproduction Programme)
UNICEF	(United Nations Children's Fund)
World Bank	
IARC	(International Agency for Research on Cancer)
European Community:	Life Sciences and Technology for Developing Countries

### 2 *Bilateral Agencies*

USAID	(United States Agency for International Development)
IDRC	(International Development Research Centre)
SAREC	(Swedish Agency for Research Cooperation with Developing Countries)
GTZ	(Deutsche Gesellschaft für Technische Zusammenarbeit)
JICA	(Japanese International Cooperation Agency)
BOSTID	(Board on Science and Technology for International Development)
CIDA	(Canadian International Development Agency)
SIDA	(Swedish International Development Agency)
ODA	(Overseas Development Agency) (UK)
ADAB	(Australian Development Assistance Board)
DGIS	(Department for International Cooperation, Ministry for Foreign Affairs, the Netherlands)

### 3 *Private Foundations*

Rockefeller Foundation  
 Carnegie Corporation  
 Ford Foundation (Child Health)  
 Kellogg Foundation (Health Services; primary interest in Latin America)  
 McArthur Foundation

### 4 *National Sources*

These will vary from country to country.

**FINALIZING AND REVIEWING  
THE RESEARCH PROPOSAL**

# FINALIZING AND REVIEWING THE RESEARCH PROPOSAL

## Objectives

By the end of this Module, the participants should be able to:

- finalize the research proposal for presentation to the relevant authorities;
- write a brief summary of the completed research proposal.

## Contents

- 1 Finalizing the Research Proposal
- 2 Writing a Summary of the Research Proposal
- 3 Presenting the Research Proposal to the Relevant Authorities

\* Adapted from Module 18, Health Systems Research Training Series, Volume 2

## 1 Finalizing the Research Proposal

When you have finished the methodological section of your research proposal and have pretested the methodology or at least reviewed it thoroughly, you can start preparing the final draft of various parts of your research proposal.

The *outline* of your research proposal is as follows:

### Table of Contents

#### Summary

#### 1 Introduction

- 1.1 Background information
- 1.2 Statement of the problem
- 1.3 Literature review

#### 2 Objectives and Research Questions

#### 3 Methodology

- 3.1 Study type, variables, data collection techniques
- 3.2 Sample
- 3.3 Plan for data collection
- 3.4 Plan for data processing and analysis
- 3.5 Ethical considerations
- 3.6 Pretest

#### 4 Project Management

- 4.1 Staffing and work plan
- 4.2 Administration and monitoring
- 4.3 Plan for utilization and dissemination of results

#### 5 Budget

- 5.1 Budget
- 5.2 Budget justification

#### Annexes

- Annex 1 References
- Annex 2 List of abbreviations (if applicable)
- Annex 3 Questionnaires (and/or other data collection tools)

- 1 The first section of your proposal contains background information, the statement of the problem, and literature review. This section should convince the reader of the relevance of the study (magnitude, severity of the problem). It should provide enough background data for an outsider to understand the factors influencing the problem and the setting in which it occurs. Your review of available literature and reports should further illustrate why the problem is important, not only in your own working area, but probably also beyond.

You can justify your study by pointing to the gaps in available information that you hope to fill with the data from your planned research. Finally, you can increase the interest of your readers by summarizing what results you hope will emerge from your study and how you plan to use them to help solve or alleviate the problem on which your study concentrates.

You, therefore, have to thoroughly review the various pieces of text that you have produced during earlier sessions of the workshop, and rewrite them to form a coherent proposal.

When developing your research methodology you may have somewhat revised your focus on the research problem; you may have become more specific, added certain factors or omitted others. These changes should be made on the text of your proposal because all parts of the study should be consistent and logically connected to each other.

- 2 The second section of your proposal focuses on the research objectives and the research questions. Review these critically. Determine whether all changes made during the development of your data collection tools have been added.
- 3 The next section presents the methodology. You have already prepared small sections focusing on various aspects of your methodology. You should check the text for clarity of wording (an outsider must be able to understand what you mean) and logical coherence.
- 4 Discussion of various ethical issues affecting your study may be scattered in different parts of your draft. Identify the most important issues and discuss them in a separate section (include, for example, issues relative to the selection of your topic, your methodology, and the collection of your data).
- 5 The last sections of the research proposal, which will focus on project management, the dissemination of results, and the budget, are quite clear cut. When writing them, it may be useful to refer to the directions presented in the group work sections of the respective Modules.
- 6 Annexes. Your list of references can be Annex 1. You might like to add a list of abbreviations, if there are many. In addition, your data collection tools should be annexed, each with a number, so that you can easily refer in the text to the various instruments.

## 2 Writing a Summary of the Research Proposal

When you have completed writing your research proposal, there is usually a need for the protocol to be reviewed by senior authorities and policy-makers or funding agencies. For the purpose of obtaining approval from policy-makers or very busy administrators, it is advisable to add a summary (of no more than two pages) to the proposal.

A *summary* usually includes:

- 1 One page containing essential information such as:
  - title of the research proposal;
  - duration (dates of onset and completion of the project);
  - total budget (in local currency and US\$):
    - contribution of ministry of health;
    - contribution of donor;
  - research team (names and functions):
    - principal investigator;
    - co-investigators;
  - name of principal administrator.
  
- 2 A brief narrative summary of one page, which could contain the following elements:
  - one paragraph on the statement of the problem;
  - general objective;
  - sampling and data collection techniques used; and
  - indications concerning what major results may be expected from the study.

You should put the summary at the beginning of the proposal, although it is the last thing you prepare.

After the summary, a *table of contents* should follow. Adding numbers to the pages of your report and including them in your table of contents is one of the last activities involved in preparing your proposal.

Then a *title page* should be prepared, containing the title of your study, the names of the researchers with their titles, the name of the institution that has organized the course (Ministry of Health, or health research unit of the ministry of health, for example), and date of issue. Add to the title page that this is a *research proposal*, to avoid confusion with your research report which most likely will bear the same title.

### 3 Presenting the Research Proposal to the Relevant Authorities

Before a research project can be implemented, the AHR proposal usually has to be:

- approved by the relevant health authorities;
- approved by the appropriate research committee or council; and
- given the funding.

In certain circumstances some of the above steps may be combined.

The procedure for approval may require that the research proposal be submitted with an accompanying letter or prescribed forms to the relevant authority. In addition, the researcher may be requested to make a brief verbal presentation or ‘defend’ the proposal in person.

During the workshop, participants can make 7-10 minute presentations of their research proposals to a panel, so they can gain an appreciation of the concerns of the various approving agencies and to acquire the skills to respond briefly and succinctly to questions relating to particular aspects of the proposal.

In case a research proposal is presented verbally, the presentation should emphasize the following main points:

- 1 Title of the study.
- 2 A brief description of the problem, why the study is needed, what information is needed, and how such information will be used.
- 3 Objectives of the study.
- 4 Main research questions.
- 5 A brief statement on the type of study design, sample, and methods of data collection.
- 6 A summary of how the study will be implemented (where, by whom, when, etc.).
- 7 A summary of how data will be analyzed to provide the required information.
- 8 A summary of the main resources required (e.g. manpower, budget, transport).
- 9 A brief summary of ethical considerations and plan for dissemination of results.

Although the presentation itself should be brief, participants should be prepared to respond to detailed questions on any of the aspects of the proposal that have been presented.

If you submit your proposal, accompanying letters should contain the title, the name of the principal investigator and principal administrator, and the period over which you hope to carry out the study. If a letter is going to the national research council or a similar group you may briefly refer to your study's methodology and expected results and mention where further details can be found in your proposal. In letters to potential donors, you should state the total amount required and the account to which the money, if granted, should be transmitted.



---

## Assignment

- 1 Prepare a final draft of your proposal following the guidelines presented above.
  - 2 Take care that you number the sections, for example as in the outline presented in this Module. In the final editing make sure that the text flows smoothly from one section to the next.
  - 3 As the principal investigator, you are responsible for coordinating the production of the final draft of the proposal.
-



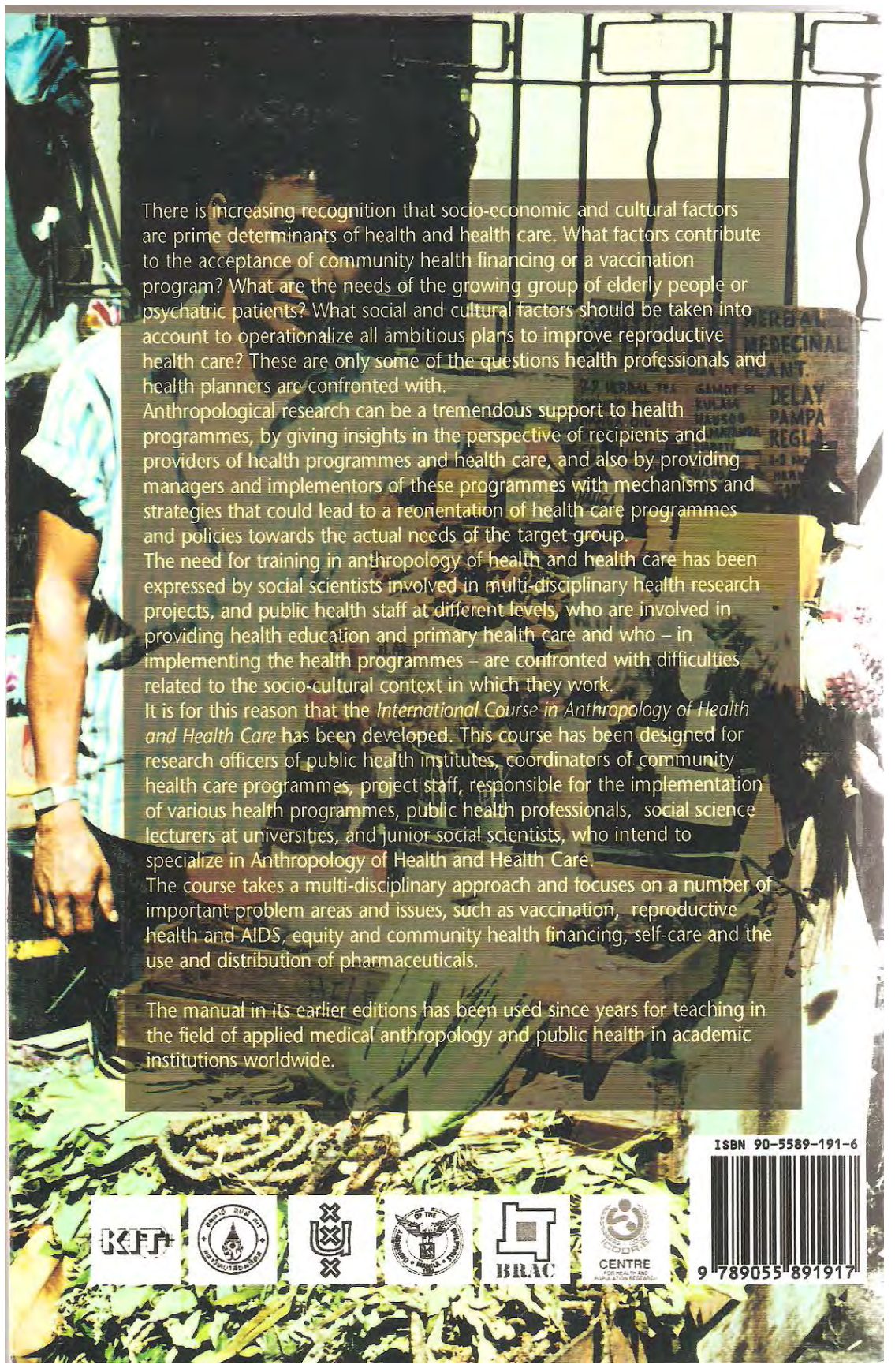

There is increasing recognition that socio-economic and cultural factors are prime determinants of health and health care. What factors contribute to the acceptance of community health financing or a vaccination program? What are the needs of the growing group of elderly people or psychiatric patients? What social and cultural factors should be taken into account to operationalize all ambitious plans to improve reproductive health care? These are only some of the questions health professionals and health planners are confronted with.

Anthropological research can be a tremendous support to health programmes, by giving insights in the perspective of recipients and providers of health programmes and health care, and also by providing managers and implementors of these programmes with mechanisms and strategies that could lead to a reorientation of health care programmes and policies towards the actual needs of the target group.

The need for training in anthropology of health and health care has been expressed by social scientists involved in multi-disciplinary health research projects, and public health staff at different levels, who are involved in providing health education and primary health care and who – in implementing the health programmes – are confronted with difficulties related to the socio-cultural context in which they work.

It is for this reason that the *International Course in Anthropology of Health and Health Care* has been developed. This course has been designed for research officers of public health institutes, coordinators of community health care programmes, project staff, responsible for the implementation of various health programmes, public health professionals, social science lecturers at universities, and junior social scientists, who intend to specialize in Anthropology of Health and Health Care.

The course takes a multi-disciplinary approach and focuses on a number of important problem areas and issues, such as vaccination, reproductive health and AIDS, equity and community health financing, self-care and the use and distribution of pharmaceuticals.

The manual in its earlier editions has been used since years for teaching in the field of applied medical anthropology and public health in academic institutions worldwide.

ISBN 90-5589-191-6



9 789055 891917

