



## UvA-DARE (Digital Academic Repository)

### Task assignment and coaching

Dominguez-Martinez, S.

**Publication date**  
2009

[Link to publication](#)

#### **Citation for published version (APA):**

Dominguez-Martinez, S. (2009). *Task assignment and coaching*. Amsterdam School of Economics, University of Amsterdam.

#### **General rights**

It is not permitted to download or to forward/distribute the text or part of it without the consent of the author(s) and/or copyright holder(s), other than for strictly personal, individual use, unless the work is under an open content license (like Creative Commons).

#### **Disclaimer/Complaints regulations**

If you believe that digital publication of certain material infringes any of your rights or (privacy) interests, please let the Library know, stating your reasons. In case of a legitimate complaint, the Library will make the material inaccessible and/or remove it from the website. Please Ask the Library: <https://uba.uva.nl/en/contact>, or a letter to: Library of the University of Amsterdam, Secretariat, Singel 425, 1012 WP Amsterdam, The Netherlands. You will be contacted as soon as possible.

# Task assignment and coaching\*

Silvia Dominguez-Martinez<sup>†</sup>

*University of Amsterdam*

## Abstract

An important task of a manager is to motivate her subordinates. One way in which a manager can give incentives to junior employees is through the assignment of tasks. How a manager allocates tasks in an organization, provides information to the junior employees about his ability.

Without coaching from a manager, the junior employee only has information about his past performance. Based on his past performance, a talented junior who has performed a difficult task sometimes decides to leave the organization. The introduction of a manager who coaches the junior may lead to better future decisions of the junior. The role of the manager is twofold. First, the manager assigns a task to the junior upon arrival at the organization. Second, the manager provides feedback on the difficulty of the performed task. If preferences of the junior and the manager are disaligned, the manager assigns too often an easy task. The manager uses task assignment to credibly communicate that the junior is talented.

Key words: self-assessment, , difficulty task, coaching, task assignment.

JEL Classification: D81, D82, D83

---

\*I would like to thank Otto Swank and Bauke Visser for their advice and encouragement. I would also like to thank Josse Delfgaauw, Robert Dur and seminar participants at Erasmus University Rotterdam and Universiteit van Amsterdam for useful comments and suggestions.

<sup>†</sup>Address: Amsterdam School of Economics, Roetersstraat 11, 1018 WB Amsterdam, The Netherlands. Email: S.DominguezMartinez@uva.nl Tel: +31-20-5256932.

# 1 Introduction

An important task of a manager is to motivate her subordinates. Predominantly the focus in economics has been on the use of compensation to motivate employees (see Prendergast (1999) for a survey). However, sometimes managers only have limited influence on the compensation package of employees. Another way in which the manager can give incentives to employees is through the assignment of tasks. How a manager allocates tasks in a firm, provides information about the employee's ability and consequently may affect the perception an employee holds about his ability.

Numerous psychological studies emphasize that the knowledge people have about themselves is imperfect (see, for example, Baumeister, 1998). A well-known finding in social psychology is that agents rate themselves above average. For car driving Svenson (1981) shows that individuals believe themselves to be better drivers than others in the group. Kruger (1999), however, shows that this bias is only observed if individuals are asked to rate their performance on easy tasks. He shows that for domains in which absolute skills tend to be high (using mouse, driving, riding bicycle, saving money), a majority of people see themselves better than average, while for domains in which absolute skills tend to be low (telling jokes, playing chess, juggling, and computer programming), a majority of people see themselves worse than.<sup>1</sup> Hence, imperfect knowledge about one's ability can lead to overestimation of one's ability or to underestimation of one's ability.

Given that an individual's self-assessment about his ability may affect the choices he makes, having an distorted self-appraisal may have important economic consequences. Phillips (1984) shows that highly competent children with a low perception of their ability adopt lower standards and hold lower expectations for success than highly competent children with a more positive view of their ability. An implication may be that negative and distorted self-appraisals persist, because intellectually competent children avoid tasks that could provide evidence about their abilities. Ehrlinger and Dunning (2003) point out that one possible reason why women disproportionately avoid careers in science is that they underestimate their scientific reasoning ability.

---

<sup>1</sup>Kruger's result has been replicated in other experiments (Hoelzl and Rustichini, 2005; Moore and Kim, 2003; Hales and Kachelmeier, 2005).

In this paper I consider a setting in which agents do not know their own abilities, but they use their performance on a task to make an inference. The problem faced by the agent is that performance not only depends on the agent's ability, but also on the unknown difficulty of the performed task. An example of an agent who faces uncertainties about his ability and the difficulty of the performed task is a junior employee. At the beginning of his career, a junior employee rarely knows his own ability. Besides, a junior who has recently joined the organization is unable to assess the difficulty of different tasks in the organization. Frequently, the only available information to the junior is his performance on a task. Based on his performance, the junior can make an inference on his ability and the difficulty of the task. The junior's ability and the difficulty of the performed task together determine the junior's contribution to the organization. The junior employee cares about his contribution to the organization, but performing a task is costly. Given the junior's performance, his contribution to the firm is greater if the performed task was difficult than if the performed task was easy. As the junior does not know the difficulty of the performed task, he cannot perfectly determine his contribution to the organization. An implication may be that sometimes a talented junior may decide to stop performing a task after learning his performance on a difficult task, because he underestimates his contribution to the organization. Having a more precise image of his ability and about the difficulty of the performed task, enables the junior to improve future decisions. This information could be provided by the boss during a performance evaluation. However, the boss lacks the time to properly coach a junior's employee. The role of the boss is restricted to randomly assigning a task to the junior employee and to communicate the junior's performance on the task. The boss can appoint a manager to coach the junior employee. The manager is a senior employee who knows the junior's ability and the difficulty of different tasks. As the boss, the manager cares about the contribution of the junior to the organization, but he does not care about the costs a junior has to make. The role of the manager is twofold. First, she assigns a task to the junior employee upon arrival at the organization. Second, the manager may provide feedback on the difficulty of the performed task during the performance evaluation. Hence, in this paper a junior employee can learn about his ability in two ways. First, he can learn by doing.

Second, he can learn from others, i.e. the manager.<sup>2</sup>

The benefit of appointing a manager to coach the junior employee is that she can prevent a junior from taking the wrong decision. First, because of her better information, the manager can match the junior's ability and the difficulty of the task. Second, the manager can provide information to the junior about the difficulty of the task. Based on this additional information the junior employee can make a better self-assessment of his ability and his contribution to the firm. However, as the manager does not exactly have the same interests as the junior, she may have an incentive to conceal or manipulate information. An implication is that when performing a task is sufficiently costly for the junior, the manager is unable to communicate the difficulty of a task to some talented junior. As a consequence, these talented juniors might decide to stop performing the task. To prevent this from happening, the manager can assign an easy task to these juniors in the first stage. After observing their performance of this task, they infer from their performance that they are talented. Hence, the manager uses the assignment of an easy task to prevent the junior from getting demotivated after observing his performance on a difficult task.

In my paper the manager can use task assignment and feedback to motivate the junior employee. There are some papers in the economic literature that analyse the use of task assignment as an incentive device. Itoh (1994), for example, considers a principal-agent model in which the principal has to decide which tasks to delegate to agents and which tasks to perform himself. He shows that sometimes assigning a broad range of tasks to one agent provides better incentives to agents than having more agents specializing in one task. Besides he shows that under some conditions, for incentive reasons, the principal may choose to delegate all tasks to an agent instead of performing some tasks himself. My paper considers a different role of task assignment, namely task assignment may provide information about a junior employee's ability.

The manager can also use feedback on the difficulty of the performed task to coach a junior employee. Feedback has received much attention in the manage-

---

<sup>2</sup>Another way of learning is through the performance incentives offered by an informed principal. Bénabou and Tirole (2003) show that performance incentives affect the agent's perception of his own ability.

ment literature and psychology literature (see Ilgen, Fisher and Taylor (1979) and other studies cited therein). In the economic literature, however, little attention has been paid to feedback. Lizzeri, Meyer and Persico (2002) consider whether interim performance evaluations should be conducted to inform individuals about their performance on a project. Ertac (2006) investigates the amount of information the principal should disclose about the agent's performance and the performance of other agents in the organization. In her model performance also depends on a common shock (for example, task difficulty) and the agent's ability. Her analysis focuses on exploring whether and when it is optimal for the principal to inform agents about each other's performance. Information about the performance of other agents is useful to separate the effect of the common shock from the effect of ability. In my paper the focus is on how additional information about the difficulty of tasks affects the decisions of one junior employee. The message containing information about the difficulty of the performed task is costless for the manager. It is well-known in cheap-talk games that if the preferences of the principal and the agent are perfectly aligned, then communication between the principal and the agent can be perfect (Crawford and Sobel, 1982). However if the preferences of the principal and the agent are disaligned, then information may lack credibility. Also in my paper the principal has an incentive to manipulate information if preferences disaligned. In this situation the principal may use task assignment to credibly communicate the junior's ability.

More broadly, my paper is related to several economic papers that have recently appeared on the topic of self-assessment of abilities. These papers investigate why people are overoptimistic about certain life-events (see Van den Steen, 2004), why people may decide not to collect information for strategic purposes (Carrillo and Mariotti (2000) and Bénabou and Tirole (2002)), and why people may keep buying signals until their self-assessment is sufficiently favourable (Zábojník (2004) and Brocas and Carrillo (2002)). A drawback of these papers is that they only pay attention to overconfidence. However, people exist who underestimate their abilities. Dominguez-Martinez and Swank (2009) consider a model that pays attention to both overconfidence and underconfidence. In their model, individuals can learn about their abilities from appraisals of others (i.e. the senior) and experience. They show that if communication is imperfect, the senior tends to deflate the ability of

juniors who are just able and tends to inflate the ability of talented juniors. On average appraisals of others tend to be too positive. The reason is that underconfidence leading to too much passivity is permanent while overconfidence leading to too much activism is temporary because of learning by doing. In my paper underestimation also plays an important role. The possibility that a talented junior employee underestimates his ability and leaves the organization if preferences of the manager and the junior are disaligned, makes the manager assign too often an easy task at the beginning of a junior's career. Eventually by performing tasks the junior learns that he is talented. Santos-Pinto and Sobel (2005) also present a model that explains the existence of positive self-image and allows for the possibility of negative self-image. In their model, ability consists of different skills and individuals have heterogeneous production functions that determine ability as a function of multiple skills. Using their own production function, individuals make skill-enhancing investments to maximize ability and compare their final skills to the skills of other individuals. One result of their paper is that the easier is the task, the greater is the individuals positive self-image.

The remainder of the paper is organized as follows. Section 2 presents the model. Section 3 presents the consequences of introducing a manager. Finally, section 4 concludes.

## 2 Basic Model

I consider a simple model of a boss and a junior employee. The model consists of two stages, a learning stage and a decision stage. In the learning stage the junior performs a task for the boss and learns his performance on the task. In the decision stage the junior decides whether to continue performing a task or not.

At the beginning of the game, the junior's ability,  $a$ , is drawn from an uniform distribution on the interval  $[0, 1]$ . The junior does not observe his ability, he only knows the distribution. There exists a pool of tasks, a fraction  $\gamma$  of which is difficult ( $d = 1$ ), while the other tasks are easy ( $d = 0$ ). At the beginning of the game, the boss randomly draws a task from this pool and assigns this task to the junior employee. I assume that the boss lacks time and detailed information about the junior employee to match difficulty of the specific task to the junior employee's

ability. The junior does not observe the difficulty of the task, he only knows the probability that the task is difficult. In stage 1, the junior performs the assigned task. Then performance is evaluated by the boss. During a performance evaluation the boss communicates the junior's performance on the task to the junior. Information on performance is hard information and cannot be manipulated by the boss. In my model the role of the boss is limited to assigning a task to the junior employee and informing the junior about his performance.

The junior's performance ( $p$ ) on the task depends on the difficulty of the task and on the junior's ability ( $a$ ). Performance is modeled in the following way.

**Assumption 1** If the performed task is difficult, then performance is  $p = a^2$ , implying a density function of  $p$ :  $g(p) = \frac{1}{2\sqrt{p}}$ .

**Assumption 2** If the performed task is easy, then performance is  $p = a$ , implying a density function of  $p$ :  $f(p) = 1$ .

Assumption 1 and Assumption 2 capture that the same ability leads to a better performance on an easy task than on a difficult task. Notice that, on average, the junior attains a better performance on an easy task than on a difficult task.<sup>3</sup>

In stage 2, the junior decides whether (i) to stop performing the task ( $X = no$ ), (ii) to continue performing the same task ( $X = s$ ) or (iii) to perform a new task ( $X = n$ ). In the latter case the boss randomly draws a new task from the pool of tasks.

The junior wants to make a contribution to the organization by performing a task. However, performing a task is costly for the junior. More specifically, the junior employee's utility from performing a task is given by

$$U_J = d\beta p + (1 - d)p - c \tag{1}$$

where  $d \in \{0, 1\}$  is the difficulty of the performed task and  $c$  denotes the cost of performing a task.<sup>4</sup> The first two terms of (1) correspond to the junior's contribution to the organization. The junior's contribution depends on the difficulty of the

---

<sup>3</sup>The expected value of performance on an easy task equals  $\frac{1}{2}$ , while the expected value of performance on a difficult task equals  $\frac{1}{3}$ .

<sup>4</sup>I have assumed that performing an easy task and performing a difficult task is equally costly for the junior.



performed task and on the junior's ability. The junior does not observe his contribution to the organization, he only observes his performance on the task. Hence, in my model the junior employee does not know how much utility he derives from performing a task. At this point my model deviates from traditional economic models where the junior knows the utility he derives from his actions.<sup>5</sup>

I assume that  $\beta > 1$ . This assumption implies that, given  $p$ , the junior derives a higher utility from performing a difficult task than from performing an easy task. The idea behind this assumption is that, given the junior's performance, his contribution to the firm is greater if he performs a difficult task than if he performs an easy task. If the junior does not perform a task his utility is normalized to zero.

The boss benefits from the junior's contribution to the organization, but he does not care about the costs the junior has to incur to perform the task.<sup>6</sup> The payoff to the boss of having a junior perform a task is

$$U_B = d\beta p + (1 - d)p \quad (2)$$

The timing of the model can be summarized as follows. (1) Nature determines the junior's ability,  $a$ . (2) The boss randomly draws a task from a pool of tasks and assigns the task to the junior employee. (3) In stage 1, the junior performs the assigned task and learns his performance,  $p_1 \in [0, 1]$ . (4) In stage 2, the junior decides whether to (i) stop performing the task, (ii) continue performing the same task, or (iii) perform a new task. In the latter case, the boss draws a new task from the pool of tasks. If the junior stops performing a task, the game ends.

### 3 Analysis

Before solving the basic model, I will first consider the choice of a junior who is fully informed about his ability and about the difficulty of different tasks. Given his ability, the junior can choose (i) not to perform a task, (ii) to perform an easy task or (iii) to perform a difficult task. Let  $a_0$  denote the value of  $a$  for which a

---

<sup>5</sup>Recently some economic paper assume that individuals derive utility from their beliefs (see Brocas and Carrillo (2003) for a discussion).

<sup>6</sup>For simplicity, I assume that the boss cares to the same extent about the junior's contribution to the organization as the junior employee. Changing this would add a second dimension on which preferences of the boss and the junior can differ.

junior, knowing  $a$ , is indifferent between not performing a task and performing an easy task.  $a_0$  follows from

$$a_0 - c = 0 \longrightarrow a_0 = c$$

Let  $a_1$  be the ability of a junior who is indifferent between performing an easy task and performing a difficult task.  $a_1$  follows from

$$\beta a_1^2 - c = a_1 - c \longrightarrow a_1 = \frac{1}{\beta}$$

If  $c < \frac{1}{\beta}$ , then the strategy of a fully informed junior is to (i) perform no task if  $a \in [0, c)$ , (ii) perform an easy task if  $a \in \left[ c, \frac{1}{\beta} \right)$  and (iii) perform a difficult task if  $a \in \left[ \frac{1}{\beta}, 1 \right]$ . Throughout the rest of the paper I assume that  $c < \frac{1}{\beta}$ . The following lemma summarizes the junior's decision under complete information.

**Lemma 1** *Suppose  $c < \frac{1}{\beta}$ . Then (i) a junior with  $a \in [0, c)$  prefers to perform no task, (ii) a junior with  $a \in \left[ c, \frac{1}{\beta} \right)$  prefers to perform an easy task and (iii) a junior with  $a \in \left[ \frac{1}{\beta}, 1 \right]$  prefers to perform a difficult task.*

The junior in the basic model, however, has no information about his ability or about the difficulty of the task. He can learn about his ability and about the difficulty of the task by performing a task in stage 1. Then, in stage 2, the junior can use this information to decide whether or not to continue performing the task. Note that this is not a sequential move game. Only in stage 2 a decision is taken by the junior. Stage 1 is only a learning stage for the junior, no decisions are taken. To solve the game, I apply the standard Bayesian Nash equilibrium concept.

### 3.1 Stage 1: Learning stage

The junior employee learns about his ability by doing. After performing a task in the first stage, he learns his performance. As performance on a task contains information about the junior's ability, the first thing the junior does is update his ability. Suppose the junior observes a performance of  $p$ , then his expected ability will be given by

$$a_p^e = E(a | p) = \frac{(2p(1 - \gamma) + \gamma) \sqrt{p}}{2\sqrt{p}(1 - \gamma) + \gamma} \quad (3)$$

The junior's expected ability depends on the observed performance,  $p$ , and on the prior probability that a task is difficult,  $\gamma$ . Given the positive relation between performance and ability, it is not surprising that the better is the observed performance, the higher is the expected ability ( $\frac{\partial a_p^e}{\partial p} > 0$ ). Also a greater  $\gamma$  has a positive effect on the expected ability ( $\frac{\partial a_p^e}{\partial \gamma} > 0$ ). Recall that a greater  $\gamma$  indicates a greater probability of having performed a difficult task. Furthermore, attaining a performance of  $p$  on a difficult task requires a higher junior's ability than attaining the same performance on an easy task. Hence, the greater is  $\gamma$ , the greater is  $a_p^e$ .

Furthermore, the observed performance contains information about the probability that the performed task was difficult. Suppose again that the junior's performance on the task is  $p$ . Then the posterior probability that the performed task is difficult,  $\hat{\gamma}$ , is given by

$$\begin{aligned}\hat{\gamma} &= \Pr(d = 1 \mid p) = \frac{g(p)\gamma}{f(p)(1-\gamma) + g(p)\gamma} \\ \hat{\gamma} &= \frac{\gamma}{2\sqrt{p}(1-\gamma) + \gamma}\end{aligned}\tag{4}$$

The higher the observed performance,  $p$ , the lower  $\hat{\gamma}$ . More precisely, for  $p > \frac{1}{4}$ ,  $\hat{\gamma} < \gamma$ . The intuition is that attaining a high performance is more probable when performing an easy task than when performing a difficult task.

### 3.2 Stage 2: Decision junior

In stage 2 the junior takes a decision, based on his observed performance in the first stage. The junior has to decide whether (i) to stop performing the task ( $X = no$ ), (ii) to continue performing the same task ( $X = s$ ), or (iii) to perform a new task ( $X = n$ ). Suppose the junior observes a performance of  $p$  in the first stage. Then, the performance in the second stage will also equal  $p$  if the junior decides to perform the same task again ( $X = s$ ). The utility a junior employee derives from performing the same task again equals

$$EU(X = s) = \hat{\gamma}\beta p + (1 - \hat{\gamma})p - c$$

The first two terms correspond to the junior employee's contribution to the organization. The junior's contribution equals  $\beta p$  if the performed task is difficult and  $p$

if the task is easy. The probability that the performed task is difficult equals  $\hat{\gamma}$  and is given by (4).

If the junior employee decides to perform a new task ( $X = n$ ) in the second stage, then two cases have to be distinguished. First, with probability  $\hat{\gamma}$  the performed task in the first stage was difficult. This means that the observed performance of  $p$  should correspond to a junior with an ability of  $\sqrt{p}$ . Now the expected contribution in the second stage can be determined. With probability  $\gamma$  the new task is difficult and the junior's contribution equals  $\beta p$  and with probability  $(1 - \gamma)$  the new task is easy and the junior's contribution equals  $\sqrt{p}$ . Second, with probability  $(1 - \hat{\gamma})$  the performed task in the first stage was easy. Then, the observed performance of  $p$  corresponds to a junior with an ability of  $p$ . Again the expected junior's contribution to the organization in the second stage depends on the difficulty of the new task. With probability  $\gamma$  the new task is difficult and the junior's contribution is  $\beta p^2$  and with probability  $(1 - \gamma)$  the new task is easy and the junior's contribution is  $p$ . Hence, the expected utility of performing a new task in the second stage is

$$EU(X = n) = \hat{\gamma}(\gamma\beta p + (1 - \gamma)\sqrt{p}) + (1 - \hat{\gamma})(\gamma\beta p^2 + (1 - \gamma)p) - c$$

Finally stop performing a task ( $X = no$ ) yields a payoff of zero.

First, I focus on the juniors choice between performing the same task again ( $X = s$ ) and performing a new task ( $X = n$ ). The junior is indifferent between the two options if

$$EU(X = n) - EU(X = s) = 0$$

$$(1 - \hat{\gamma})\gamma(\beta p^2 - p) - \hat{\gamma}(1 - \gamma)(\beta p - \sqrt{p}) = 0 \quad (5)$$

Lemma 2 presents the roots of equation (5).

**Lemma 2** *The junior is indifferent between  $X = s$  and  $X = n$  if  $p = 0$ ,  $p = p_L$  and  $p = p_H$ , where  $p_L \in \left(0, \left(\frac{1}{\beta}\right)^2\right)$  and  $p_H \in \left(\frac{1}{\beta}, 1\right)$ .*

**Proof.** See Appendix. ■

To understand the intuition behind Lemma 2 consider Figure 1.

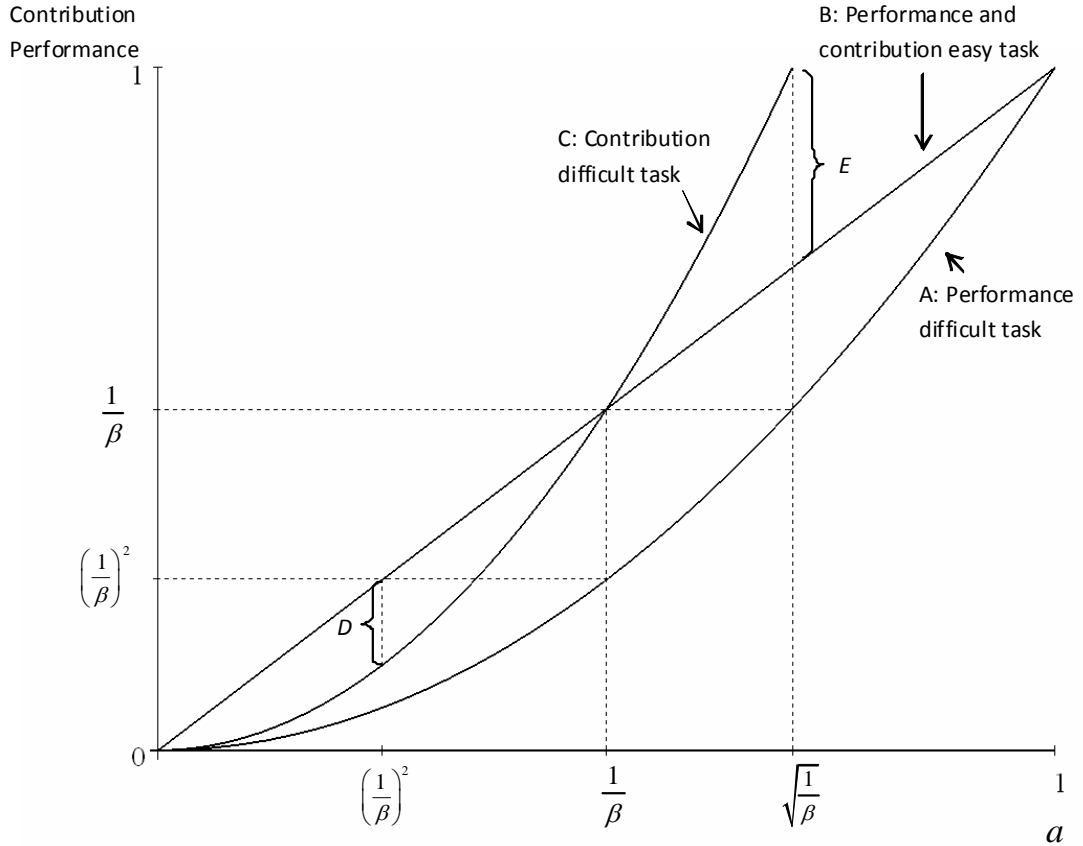

Figure 1

In the figure, curve  $A$  (curve  $B$ ) gives the relationship between the junior's ability and his performance on a difficult task (an easy task). More precisely, curve  $A$  corresponds to  $p = a^2$  and curve  $B$  corresponds to  $p = a$ . Curve  $C$  ( $B$ ) gives for each ability the corresponding junior's utility derived from contributing to the firm by performing a difficult task (an easy task).<sup>7</sup> More precisely, curve  $C$  corresponds to  $Contribution = \beta a^2$ . A junior who has an ability equal to  $\frac{1}{\beta}$  (intersection between curve  $B$  and curve  $C$ ) is indifferent between performing an easy task and a difficult task.

Suppose that the junior observes a performance of  $p \in \left[ \left(\frac{1}{\beta}\right)^2, \frac{1}{\beta} \right]$ . This performance corresponds either to a junior with an ability  $a \in \left[ \frac{1}{\beta}, \sqrt{\frac{1}{\beta}} \right]$  performing a

<sup>7</sup>Notice that if the junior performs an easy task, then his contribution to the firm equals his performance. Hence, the relationship between ability and performance and the relationship between ability and the junior's utility derived from his contribution to the firm, are represented by  $B$ .

difficult task or to a junior with an ability  $a \in \left[ \left( \frac{1}{\beta} \right)^2, \frac{1}{\beta} \right]$  performing an easy task. Let me consider the two cases separately. First, let me consider a junior with an ability  $a \in \left[ \frac{1}{\beta}, \sqrt{\frac{1}{\beta}} \right]$  performing a difficult task. Ideally, a junior with an ability greater than  $\frac{1}{\beta}$  performs a difficult task (see lemma 1). Also the figure shows that this junior derives a greater utility from performing a difficult task than from performing an easy task (curve  $C$  lies above curve  $B$ ). Hence, the junior is performing the task that yields the highest possible utility. Second, let me consider a junior with an ability  $a \in \left[ \left( \frac{1}{\beta} \right)^2, \frac{1}{\beta} \right]$  performing an easy task. Ideally, a junior with an ability smaller than  $\frac{1}{\beta}$  performs an easy task (curve  $C$  lies below curve  $B$ ). Hence, also in this case the junior is performing the task that yields the highest possible utility. Summarizing, a junior who observes a performance of  $p \in \left[ \left( \frac{1}{\beta} \right)^2, \frac{1}{\beta} \right]$  is performing the task he would perform under full information. Consequently, the junior has no incentive to perform a new task and chooses to continue performing the same task.

Now suppose that the junior observes a  $p$  just below  $\left( \frac{1}{\beta} \right)^2$ . Then, there are two possibilities. First, a performance just below  $\left( \frac{1}{\beta} \right)^2$  can result from a junior with an ability just below  $\frac{1}{\beta}$  performing a difficult task. Ideally, this junior would like to perform an easy task. In this situation performing a new task would reduce the probability that the junior performs a difficult task in the second stage, increasing the junior's utility. With a probability of  $(1 - \gamma)$  the new task is easy. Then the gains of option  $X = n$  are given by the difference between curve  $C$  and curve  $B$  at the point  $a = \frac{1}{\beta} - \varepsilon$ . The figure immediately shows that the gains are infinitesimally small. With probability  $\gamma$  the new task is difficult and then there are no gains from performing a new task. Hence, the gains from option  $X = n$  in this case are nil. Second, a performance just below  $\left( \frac{1}{\beta} \right)^2$  can result from a junior with an ability just below  $\left( \frac{1}{\beta} \right)^2$  performing an easy task. In this situation, the junior is performing the task he would choose under full information. Choosing to perform a new task increases the probability that the new task is difficult, resulting in a smaller utility for the junior. With a probability of  $\gamma$  the new task is difficult. Then, the costs of performing a new task are given by  $D$ . With a probability of  $(1 - \gamma)$  the new task is easy and there are no costs of choosing  $X = n$ . When choosing between  $X = s$  and  $X = n$  the junior trades-off the costs of performing a new task and the benefits. If performance is just below  $\left( \frac{1}{\beta} \right)^2$  the costs exceed the

benefits. Consequently, the junior chooses to perform the same task again ( $X = s$ ). The figure also illustrates that the smaller is the observed performance, the greater are the benefits resulting from performing a new task and the smaller are the costs. More generally, there exists a value  $p = p_L \in \left(0, \left(\frac{1}{\beta}\right)^2\right)$  at which the junior is indifferent between performing the same task again and performing a new task.

Finally, suppose that the junior observes a  $p$  just above  $\frac{1}{\beta}$ . Then a similar argument holds. Again, there are two possibilities. First, a performance just above  $\frac{1}{\beta}$  can result from a junior with ability just above  $\frac{1}{\beta}$  performing an easy task. Ideally, the junior would like to perform a difficult task. In this situation performing a new task would increase the probability that the junior performs a difficult task in the second stage, increasing the junior's utility. The gains of option  $X = n$  are that with a probability of  $\gamma$  the new task is difficult and the additional utility derived from option  $X = n$  is given by the difference between curve  $C$  and curve  $B$  at the point  $a = \frac{1}{\beta} + \varepsilon$ . The figure immediately shows that the gains are infinitesimally small. Second, a performance just above  $\frac{1}{\beta}$ , can result from a junior with an ability just above  $\sqrt{\frac{1}{\beta}}$  performing a difficult task. Ideally this junior performs a difficult task. Performing a new task increases the probability that the new task is easy, decreasing the junior's utility. The costs of performing a new task are that with a probability of  $(1 - \gamma)$  the new task is easy and the utility decreases by  $E$ . Again, the junior trades-off the costs of performing a new task and the benefits, when making a choice between  $X = s$  and  $X = n$ . If performance is just above  $\frac{1}{\beta}$ , the costs exceed the benefits. If the observed performance is  $p = 1$ , then the left-hand side of equation (5) is positive. This implies that if  $p = 1$ , then the junior prefers option  $X = n$ . More generally, there exists a value of  $p = p_H \in \left(\frac{1}{\beta}, 1\right)$  at which the junior is indifferent between performing the same task again and performing a new task. The following lemma summarizes the above discussion.

**Lemma 3** *Suppose the junior can choose between performing the same task again and performing a new task. Then, the junior chooses to perform the same task again if  $p = 0$  or  $p \in [p_L, p_H]$  and he chooses to perform a new task if  $p \in (0, p_L)$  or if  $p \in (p_H, 1]$ .*

Until now I have focused on the choice between performing a new task and performing the same task again. The junior, however, can also decide not to perform

a task. The utility a junior derives from not performing the task equals 0. A junior who observes a sufficiently low performance, will choose not to perform the task. For these juniors, the costs of performing the task exceed the expected benefits of performing the task. Depending on the costs of performing the task, two situations can be distinguished. Let  $c = \bar{c}$  be the cost for which the junior is indifferent between  $X = no$ ,  $X = s$  and  $X = n$  if he observes  $p = p_L$ .<sup>8</sup> If the costs are sufficiently small ( $c < \bar{c}$ ), the junior chooses to stop performing the task if  $p < p_c^L$ , where  $p_c^L$  solves

$$\hat{\gamma} \left( \gamma \beta p_c^L + (1 - \gamma) \sqrt{p_c^L} \right) + (1 - \hat{\gamma}) \left( \gamma \beta (p_c^L)^2 + (1 - \gamma) p_c^L \right) - c = 0$$

and if the cost are sufficiently high ( $c \geq \bar{c}$ ), the junior decides to stop performing the task if  $p < p_c^H$ , where  $p_c^H$  solves

$$\hat{\gamma} \beta p_c^H + (1 - \hat{\gamma}) p_c^H - c = 0$$

The following Proposition summarizes the discussion.

**Proposition 1** *Suppose that the costs are sufficiently small ( $c < \bar{c}$ ), then (i) a junior who observes  $p < p_c^L$  chooses to stop performing a task (ii) a junior who observes  $p \in [p_c^L, p_L)$  or  $p \in (p_H, 1]$  chooses to perform a new task, and (iii) a junior who observes  $p \in [p_L, p_H]$  chooses to perform the same task again. Suppose that the costs are sufficiently large ( $c \geq \bar{c}$ ), then (i) a junior who observes  $p < p_c^H$  chooses to stop performing the task, (ii) a junior who observes  $p \in [p_c^H, p_H]$  chooses to perform the same task again, and (iii) a junior who observes  $p \in (p_H, 1]$  chooses to perform a new task.*

Figure 2 illustrates the Proposition and above discussion.

---

<sup>8</sup>The value of  $\bar{c}$  can be determined as follows. Lemma 3 states that if performance equals  $p_L$  the junior is indifferent between  $X = s$  and  $X = n$ . This implies that if  $p = p_L$ ,  $EU(X = s) = EU(X = n) = \hat{\gamma} \alpha p_L + (1 - \hat{\gamma}) p_L - c$  with  $\hat{\gamma} = \frac{\gamma}{2\sqrt{p_L}(1-\gamma)+\gamma}$ . The final step is to determine  $\bar{c}$ . I have defined  $\bar{c}$  as the value of  $c$  at which  $EU(X = s) = EU(X = n) = EU(X = no)$ , that is  $\hat{\gamma} \alpha p_L + (1 - \hat{\gamma}) p_L - \bar{c} = 0$ . Hence,  $\bar{c} = \hat{\gamma} \alpha p_L + (1 - \hat{\gamma}) p_L$ .



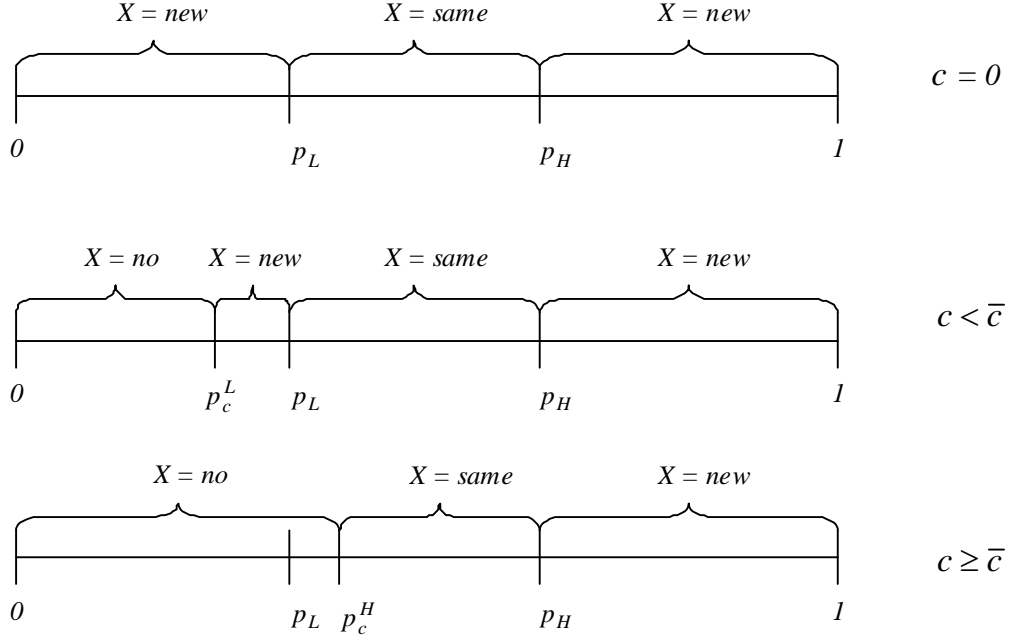

Figure 2

In my model the junior only observes his performance on a task and uses this information to make an inference about his ability and the difficulty of the performed task. Based on this information the junior decides what to do in the second stage. As the junior only has incomplete information about himself and the performed task, he sometimes makes a mistake. Broadly, the junior can make two types of mistakes. First, a highly talented junior who has performed a difficult task may decide to perform a new task after observing his performance. Take, for example, a junior with an ability equal to  $a'$  and a performance of  $p' > p_H$  after performing a difficult task. According to Lemma 1 a junior employee with  $a = a' > \frac{1}{\beta}$  prefers to perform a difficult task. However, according to Proposition 1, the junior based on his observed performance will choose perform a new task.<sup>9</sup> Second, a talented junior who has performed a difficult task may decide to stop performing a task if the costs of performing a task are sufficiently large. Take, for example, a junior with ability  $\hat{a} > \frac{1}{\beta}$  and a performance of  $\hat{p} < p_c^H$  after performing a difficult task.

---

<sup>9</sup>The same type of mistake is made by a low ability junior. Take, for example, a junior with an ability equal to  $a''$  and a performance of  $p'' < p_L$  after performing an easy task. A junior employee with  $a = a'' < \left(\frac{1}{\beta}\right)^2$  prefers to perform an easy task. However, the junior, based on his observed performance, will choose to perform a new task.

Furthermore, suppose that  $c > \bar{c}$ . Then, according to Proposition 1, the junior decides to stop performing the task. However, if the junior were to have complete information about his ability and the difficulty of the performed task, then he would decide to continue with the task. In both cases the junior employee takes the wrong decision because he does not have complete information about his ability and about the difficulty of the tasks. Both types of mistakes are costly for an organization. How can an organization prevent a junior employee from making mistakes? One way is by having a manager who assigns tasks and provides additional information to junior employees.

## 4 Extension: The manager

In this section the basic model is extended by introducing a manager. The boss delegates the supervision and coaching of junior employees to managers. The main difference between the boss and the manager is that the manager has more time to coach junior employees and therefore can better determine the junior employee's ability. One could think of the manager as a senior employee at the organization. The manager knows both the difficulty of the different tasks and she knows the junior employee's ability. Hence, she can assign the task that fits the junior employee's ability best. The remainder of the section is organized as follows. First, the extended model will be presented. Second, the equilibrium of the extended model will be discussed.

### 4.1 Extension: The model

The boss appoints a manager to coach the junior employee. The role of the manager is twofold. First, the manager decides whether to assign no task, assign an easy task or assign a difficult task to the junior employee. Second, the manager provides feedback about the difficulty of the performed task.

The timing is as follows. At the beginning of the game, Nature draws the junior's ability and a subset of tasks, a fraction  $\gamma$  of which is difficult. The manager observes the junior's ability and the difficulty of the different tasks in the subset. As in the basic model, the junior neither observes his ability nor the difficulty of the tasks. Then, in stage 0, the manager assigns no task ( $t = n$ ), assigns an easy task ( $t = 0$ )

or assigns a difficult task(  $t = 1$ ). Stage 1 represents again a learning stage for the junior and consists of two parts. To make comparison with the previous sections possible I will refer to the parts as stage 1a and stage 1b. In stage 1a, the junior performs the assigned task and performance on the task is evaluated by the boss. The boss communicates the junior's performance on the task to the junior during a performance evaluation. Performance information is hard information and cannot be manipulated by the boss. In stage 1b, the manager sends a message about the difficulty of the task  $m \in \{0, 1\}$ ,  $m = 0$  denoting "task is easy" and  $m = 1$  denoting "task is difficult".<sup>10</sup> Information on the difficulty of the task can be manipulated by the manager. The junior employee learns about his ability by doing and from the feedback he receives from his manager. Then, in stage 2, the junior decides whether to (i) stop performing the task ( $X = no$ ), (ii) continue performing the same task ( $X = s$ ), or (iii) perform a new task ( $X = n$ ). The utility a junior derives from performing a task is represented by (1). The manager derives utility from the junior's contribution to the organization, but she does not care about the costs the junior has to incur. The manager's utility is given by

$$U_M(X = s) = d\beta p + (1 - d)p \quad (6)$$

Hence, the manager has the same preferences as the boss.<sup>11</sup> If the junior does not perform a task, the manager's utility is normalized to zero.

## 4.2 Extension: Equilibrium

First the manager has to decide whether to assign no task, assign an easy task or assign a difficult task. From the manager's preferences (see 6) it follows that the manager wants a junior with an ability smaller than  $\frac{1}{\beta}$  to perform an easy task, and she wants a junior with an ability larger than  $\frac{1}{\beta}$  to perform a difficult task. Notice that the manager always wants the junior to perform a task. Henceforth, the

---

<sup>10</sup>In the game the junior receives a message about the difficulty of the task. Similar results are obtained if the message would contain information about the junior's ability.

<sup>11</sup>In my model the manager and the boss are two different persons. One could think of a large organization where the boss has no time to supervise all his junior employees and delegates this task to a manager. Of course one can also apply the results to a situation where the manager and the boss are the same person. Then the basic model considers a situation without coaching and the extended model a situation with coaching.

manager always assigns a task in stage 0. Suppose the strategy of the manager is given by

$$\begin{cases} t = 0 & \text{if } a < \frac{1}{\beta} \\ t = 1 & \text{if } a \geq \frac{1}{\beta} \end{cases}$$

As in the basic model, in stage 1a, the junior performs the assigned task. After performing the task, the junior learns his performance. Given the manager's strategy, in some cases the observed performance reveals the difficulty of the performed task. Figure 3 provides an illustration. The relationship between observed performance and ability is given by the lines AA and BB. The relationship consists of two parts; a junior with an ability smaller than  $\frac{1}{\beta}$  is assigned an easy task (AA) and a junior with an ability larger than or equal to  $\frac{1}{\beta}$  is assigned a difficult task (BB).

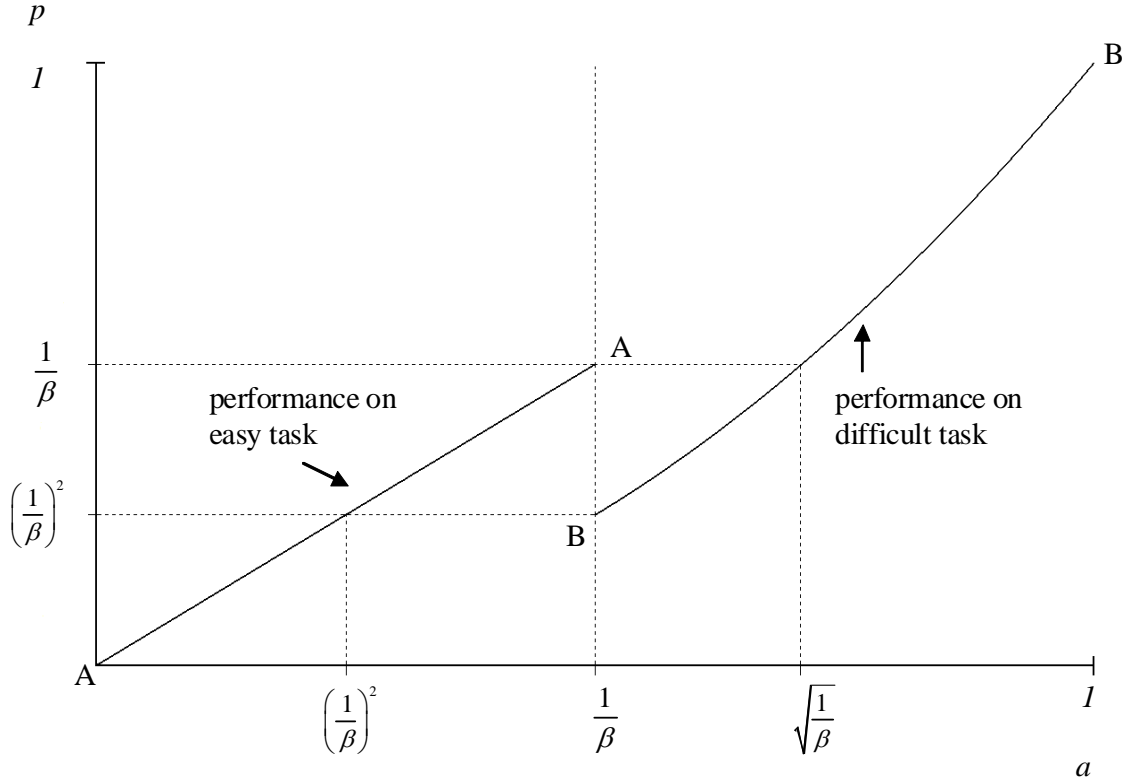

Figure 3

Suppose that a junior observes a performance smaller than  $\left(\frac{1}{\beta}\right)^2$ , then he knows that the performed task was easy. The strategy of the manager tells us that a junior with  $a < \frac{1}{\beta}$  performs an easy task yielding a performance in the range  $\left[0, \frac{1}{\beta}\right)$  and

a junior with  $a \geq \frac{1}{\beta}$  performs a difficult task yielding a performance in the range  $\left[\left(\frac{1}{\beta}\right)^2, 1\right]$ . This implies that a performance of  $\left[0, \left(\frac{1}{\beta}\right)^2\right)$  can only correspond to a junior who has performed an easy task. A similar argument holds for a junior who observes a performance larger than  $\frac{1}{\beta}$ . Suppose that a junior observes a performance larger than or equal to  $\frac{1}{\beta}$ , then he knows that the performed task was difficult. This implies that the manager will send the message  $m = 0$  to juniors with an ability of  $\left[0, \left(\frac{1}{\beta}\right)^2\right)$  and the message  $m = 1$  to juniors with an ability  $\left[\sqrt{\frac{1}{\beta}}, 1\right]$ . The manager has no incentive to manipulate the information as the junior can perfectly determine the difficulty of the task after observing his performance. The message of the manager is superfluous. In this situation the junior learns his ability. In stage 2 the junior decides to stop performing the task if  $a < c$  and continues with the same task otherwise.

More interesting is the message of the manager to juniors with an ability between  $\left[\left(\frac{1}{\beta}\right)^2, \sqrt{\frac{1}{\beta}}\right)$ . Without information about the difficulty of the task, the junior's decision,  $X_2 \in \{0, 1, 2\}$ , is given in Proposition 1. Depending on the costs of performing a task two situations can be distinguished. First, suppose that the costs of performing a task are smaller than  $\left(\frac{1}{\beta}\right)^2$ . Suppose that the strategy of the manager is to send a message that reveals the difficulty of the task to the junior. Then given the manager's message, a junior employee learns his ability and his best response is to continue performing an easy task if his ability is  $\left(\frac{1}{\beta}\right)^2 < a < \frac{1}{\beta}$ . As  $c < \left(\frac{1}{\beta}\right)^2$ , performing an easy task ( $U(X = s \mid d = 0, a) = a - c$ ) yields more than not performing a task ( $U(X = no) = 0$ ) if  $\left(\frac{1}{\beta}\right)^2 < a < \frac{1}{\beta}$ . The best response of a junior with ability  $\frac{1}{\beta} < a < \sqrt{\frac{1}{\beta}}$  is to continue performing a difficult task. Also without the message of the manager, a junior with an ability between  $\left[\left(\frac{1}{\beta}\right)^2, \sqrt{\frac{1}{\beta}}\right)$  would decide to continue performing the same task if  $c < \left(\frac{1}{\beta}\right)^2$  (see Proposition 1 with  $p_c^L < c < p_L < \left(\frac{1}{\beta}\right)^2$ ). The main difference is that the junior would not learn his ability in that situation. Above discussion is summarized in the following Proposition.

**Proposition 2** *Suppose that  $c < \left(\frac{1}{\beta}\right)^2$ . Then the manager in stage 0 (i) assigns an easy task ( $t = 0$ ) if  $0 \leq a < \frac{1}{\beta}$  and (ii) assigns a difficult task ( $t = 1$ ) if  $\frac{1}{\beta} \leq a \leq 1$ . In stage 1 the junior observes performance on the assigned task and receives a message*

about the difficulty of the task. The manager sends  $m = 0$  if  $t = 0$  and  $m = 1$  if  $t = 1$ . In stage 2, the junior decides to stop performing the task if  $a < c$  and decides to continue with the same task otherwise.

Second, suppose that the costs of performing a task are larger than  $\left(\frac{1}{\beta}\right)^2$ , then the manager will sometimes have an incentive to manipulate the information about the difficulty of the task. In this situation the manager will always send the message that the task is difficult to juniors with an ability between  $\left[\left(\frac{1}{\beta}\right)^2, \sqrt{\frac{1}{\beta}}\right)$ .<sup>12</sup> The manager's message contains no information for the junior observing a performance of  $\left[\left(\frac{1}{\beta}\right)^2, \frac{1}{\beta}\right)$ . Therefore, his decision,  $X_2 \in \{0, 1, 2\}$ , is given in Proposition 1. If  $p_c = \min\{p_c^L, p_c^H\} < \left(\frac{1}{\beta}\right)^2$  the junior will decide to continue performing the same task. Given the strategy of the junior employee, the strategy of the manager is a best response. The following Proposition summarizes this result.

**Proposition 3** *Suppose that  $c \geq \left(\frac{1}{\beta}\right)^2$  and  $p_c < \left(\frac{1}{\beta}\right)^2$ . Then the manager in stage 0 (i) assigns an easy task ( $t = 0$ ) if  $0 \leq a < \frac{1}{\beta}$  and (ii) assigns a difficult task ( $t = 1$ ) if  $\frac{1}{\beta} \leq a \leq 1$ . In stage 1 the junior observes performance on the assigned task and receives a message about the difficulty of the task. The manager sends  $m = 0$  if  $t = 0$  and  $0 \leq a < \left(\frac{1}{\beta}\right)^2$  and  $m = 1$  otherwise. Then, in stage 2, the junior decides to stop performing the task if  $p < \left(\frac{1}{\beta}\right)^2$  and decides to continue with the same task otherwise.*

If  $p_c \geq \left(\frac{1}{\beta}\right)^2$ , then a junior who observes a performance between  $\left(\frac{1}{\beta}\right)^2$  and  $p_c$  decides to stop performing a task (see Proposition 2). This means that low ability junior employees with  $\left(\frac{1}{\beta}\right)^2 < a < p_c$  performing an easy task will stop performing a task. But, also talented juniors with  $\frac{1}{\beta} < a < \sqrt{p_c}$  performing a difficult task will stop performing the task. Specially having talented juniors stop performing a task is costly for the organization. Can this be prevented by having a manager provide additional information? The answer is in the negative. The manager is unable to credibly communicate the difficulty of the task to juniors with ability  $\frac{1}{\beta} < a < \sqrt{p_c}$ . A manager always wants the junior to perform a task (independent

---

<sup>12</sup>What is important is that by lying the manager can prevent a junior with  $\left(\frac{1}{\alpha}\right)^2 \leq a < c$  from learning his ability after observing  $m = 0$ . A variant is (i) send  $m = 0$  if  $c < a < \frac{1}{\alpha}$  and  $t = 0$  and (ii) send  $m = 1$  otherwise.

of the junior's ability). Therefore, to induce the junior to continue with the task, the manager always has an incentive to send  $m = 1$  to a junior with a performance between  $\left(\frac{1}{\beta}\right)^2$  and  $p_c$ . The only instrument the manager has at hand to prevent a talented junior from not performing a task in the second stage is by distorting the task assignment. Suppose that the strategy of the manager is  $t = 0$  if  $a < \sqrt{p_c}$  and  $t = 1$  if  $a \geq \sqrt{p_c}$ . Hence, a junior with ability  $\frac{1}{\beta} < a < \sqrt{p_c}$  is assigned an easy task, while his contribution to the organization would be larger if he were to perform a difficult task. The next step is to determine how the junior will respond to the manager's strategy. After performing the assigned task the junior learns his performance. Given the strategy of the manager a junior who observes a performance between 0 and  $p_c$  knows the performed task was easy and that his ability is  $a = p$ . In this situation the manager sends  $m = 0$ . A junior who observes a performance between  $\sqrt{p_c}$  and 1 knows the performed task was difficult and that his ability is  $a = \sqrt{p}$ . In this situation the manager sends  $m = 1$ . Finally, a junior who observes a performance between  $p_c$  and  $\sqrt{p_c}$  is unable to determine the difficulty of the task from the observed performance. Without information about the difficulty of the task, the junior employee decides to continue performing the same task (see Proposition 1). The manager wants a junior with a performance between  $p_c$  and  $\frac{1}{\beta}$  to continue doing the same task. To guarantee this the manager manipulates the information about the difficulty of the task and she will send  $m = 1$  independent of the difficulty of the performed task. The manager also wants a junior with a performance between  $\frac{1}{\beta}$  and  $\sqrt{p_c}$  to continue performing a task. However, both the manager and the junior are better off if a junior employee who currently is performing an easy task, switches to a difficult task in the second stage. Therefore, the manager has an incentive to reveal that the performed task was easy (send  $m = 0$ ) to juniors with a performance between  $\frac{1}{\beta}$  and  $\sqrt{p_c}$ . Besides, in the second stage, the manager will assign a difficult, task to juniors with  $\frac{1}{\beta} < a < \sqrt{p_c}$ . The following Proposition summarizes the results.

**Proposition 4** *Suppose that  $c \geq \left(\frac{1}{\beta}\right)^2$  and  $p_c \geq \left(\frac{1}{\beta}\right)^2$ . Then an equilibrium exists in which the manager (i) assigns an easy task if  $a < \sqrt{p_c}$  and assigns a difficult task otherwise. In stage 1 the junior performs the task and observes his performance. The manager sends  $m = 0$  if  $0 \leq a < p_c$  or  $\frac{1}{\beta} \leq a < \sqrt{p_c}$  and  $m = 1$  otherwise. Furthermore, the manager assigns a new difficult task to a junior with  $\frac{1}{\beta} \leq a <$*

$\sqrt{p_c}$ . Then, in stage 2, the junior decides to (i) stop performing a task if  $p < p_c$ , (ii) perform a new task if  $\frac{1}{\beta} < p < p_c$  and  $m = 0$ , and (iii) perform the same task again otherwise.

The Proposition shows that the manager has an incentive to assign too often an easy task in the first stage. The intuition is that the manager is unable to communicate the difficulty of the task to the junior. To avoid that a talented junior gets discouraged after observing his performance on a difficult task, the manager assigns him an easy task in the first stage. After observing his performance on the task the junior learns he is able enough to perform a difficult task in the organization. In this way the manager prevents a talented junior from quitting a task. If the manager were not to distort the task assignment, a junior with  $\frac{1}{\beta} \leq a < \sqrt{p_c}$  would stop perform a task and would not learn his true ability.

## 5 Conclusion

I have developed a model that describes the interaction between a junior employee and a boss. In this model, the junior has no information about his ability, but he can use his performance on a task to make an inference. The problem is that performance not only depends on the junior's ability, but also on the unknown difficulty of the task. An implication is that a wrong self-assessment may result in a mistaken future decision. Sometimes a talented junior after observing his performance on a difficult task may decide to stop performing the task.

Having a talented junior leave the organization is costly. To prevent this from happening, the boss can appoint a manager to coach junior employees. The role of the manager is twofold. First, the manager decides which task she assigns to the junior employee. Second, the manager may provide information on the difficulty of the performed task. The manager knows the junior's ability and the difficulty of the different tasks. Therefore, she can match the junior's ability and the difficulty of the task. However, as the manager and the junior employees have different preferences, the manager may not always act in the junior employee's best interest. A consequence is that the manager may be unable to credibly communicate the difficulty of the task to some junior employees. An implication is that when performing a task is sufficiently costly, talented juniors may decide to stop performing the task



after observing performance on a difficult task. To prevent talented juniors from not performing a task, the manager distorts the task assignment in the first stage. Instead of assigning a difficult task (which would result in a higher payoff), she assigns an easy task. After observing his performance on the task, the junior learns that he is of high ability and will continue at the organization. Hence, sometimes the manager assigns too often an easy task, to prevent talented juniors from leaving the organization. Preventing a junior from leaving the organization comes at the costs of a lower first stage payoff.

## 6 Appendix

In this Appendix, I provide a proof for Lemma 2. Lemma 2 consists of two parts. First it states that equation 5 has three roots. Second, it states that  $p_L \in \left(0, \left(\frac{1}{\beta}\right)^2\right)$  and that  $p_H \in \left(\frac{1}{\beta}, 1\right)$ .

To determine that equation (5) has three roots, first I fill  $\hat{\gamma} = \frac{\gamma}{2\sqrt{p}(1-\gamma)+\gamma}$  into equation (5) and rewrite it in the following way

$$\begin{aligned} \frac{2\sqrt{p}(1-\gamma)}{2\sqrt{p}(1-\gamma)+\gamma}\gamma(\beta p^2-p) - \frac{\gamma}{2\sqrt{p}(1-\gamma)+\gamma}(1-\gamma)(\beta p - \sqrt{p}) &= 0 \\ \frac{(1-\gamma)\gamma\sqrt{p}}{2\sqrt{p}(1-\gamma)+\gamma}(2\beta p^2 - 2p - \beta\sqrt{p} + 1) &= 0 \end{aligned}$$

Now, I can determine that the first root of the equation is  $p = 0$ . Next, to proof that  $2\beta p^2 - 2p - \beta\sqrt{p} + 1 = 0$  has two roots, I take three steps. First, I determine that  $r = 2\beta p^2 - 2p - \beta\sqrt{p} + 1$  has a local minimum at  $p^*$ . Taking the first derivative with respect to  $p$  I can determine the optimum  $p = p^*$ , where  $p^*$  solves  $4\beta p^* - 2 - \frac{\beta}{2\sqrt{p^*}} = 0$ . The second derivative tells us that the optimum is a minimum,  $\frac{\partial^2 r}{\partial p^2} = 4\beta + \frac{\beta}{4p\sqrt{p}} > 0$ . Second, I have to show that the minimum is negative. Filling  $p = \frac{1}{\beta}$  into  $r$  gives  $r = 2\beta\left(\frac{1}{\beta}\right)^2 - 2\left(\frac{1}{\beta}\right) - \beta\sqrt{\frac{1}{\beta}} + 1 < 0$  ( $\beta > 1$ ), implying that the minimum has to be negative. Third, I have to show that  $r$  is positive for small values of  $p$  and for high values of  $p$ . Filling  $p = 0$  and  $p = 1$  into  $r$  gives  $r > 0$  for  $p = 0$  and for  $p = 1$ . Summarizing  $2\beta p^2 - 2p - \beta\sqrt{p} + 1 = 0$  has two roots. Let the roots be  $p_L$  and  $p_H$ .

Second, I have to show that  $p_L \in \left(0, \left(\frac{1}{\beta}\right)^2\right)$  and that  $p_H \in \left(\frac{1}{\beta}, 1\right)$ . The second part I have already proven. I have shown that if  $p = \frac{1}{\beta}$  then  $r < 0$  and that if  $p = 1$ , then  $r > 0$ . Hence,  $p_H \in \left(\frac{1}{\beta}, 1\right)$ . What remains to be proven is that  $p_L \in \left(0, \left(\frac{1}{\beta}\right)^2\right)$ . Filling  $p = \left(\frac{1}{\beta}\right)^2$  into  $r$  gives  $r = 2\beta\left(\frac{1}{\beta}\right)^4 - 2\left(\frac{1}{\beta}\right)^2 - \beta\frac{1}{\beta} + 1 < 0$  ( $\beta > 1$ ). I have already shown that if  $p = 0$ , then  $r > 0$ . Hence,  $p_L \in \left(0, \left(\frac{1}{\beta}\right)^2\right)$ . ■

## References

- [1] Baumeister, R.F. (1998). The self. In Gilbert, D.T., S.T. Fiske and G. Lindzey (eds.). *The handbook of social psychology*, New York: McGraw Hill, 680-740.
- [2] Bénabou, R. and J. Tirole (2002). Self-confidence and personal motivation. *Quarterly Journal of Economics*, 117 (3), 871-915.
- [3] Bénabou, R. and J. Tirole (2003). Intrinsic and extrinsic motivation. *Review of Economic Studies*, 70, 489-520.
- [4] Brocas, I. and J. D. Carrillo (2002). Are we all better drivers than average? Self-perception and biased behaviour. CEPR Discussion Paper No. 3603.
- [5] Brocas, I. and J. D. Carrillo (2003). *The psychology of economic decisions*. Oxford University Press.
- [6] Carrillo, J. D. and T. Mariotti (2000). Strategic ignorance as a self-disciplining device. *Review of Economic Studies*, 67, 529-544.
- [7] Crawford, V.P. and J. Sobel (1982). Strategic Information Transmission. *Econometrica*, 50 (6), 1431-1451.
- [8] Dominguez-Martinez, S. and O. H. Swank (2009). A simple model of self-assessment, forthcoming *Economic Journal*.
- [9] Ehrlinger, J. and D. Dunning (2003). How chronic self-views influence (and mislead) estimates of performance. *Journal of Personality and Social Psychology*, 84, 5-17.
- [10] Ertac, S. (2006). Social comparisons and optimal information revelation: Theory and experiments. Working paper, University of California.
- [11] Hales, J. and S. J. Kachelmeier (2005). Task difficulty and the tendency to overestimate or underestimate relative performance. Working paper.
- [12] Hoelzl, E. and A. Rustichini (2005). Overconfident: Do you put your money on it? *Economic Journal*, 115, 305-318.

- [13] Ilgen, D.R., C.D. Fisher, and M.S. Taylor (1979). Consequences of Individual Feedback on Behavior in Organizations. *Journal of Applied Psychology*, 64 (4), 349-371.
- [14] Itoh, H. (1994). Job design, delegation and cooperation: A principal-agent analysis, *European Economic Review*, 38, 691-700.
- [15] Kruger, J. (1999). Lake Wobegon be gone! The "below-average effect" and the egocentric nature of comparative ability judgments. *Journal of Personality and Social Psychology*, 77 (2), 221-232.
- [16] Lizzeri, A., Meyer, M.A., and N. Persico (2002). The incentive effects of interim performance evaluations. Caress Working Paper 02-09.
- [17] Moore, D. A. and T. G. Kim (2003). Myopic social prediction and the solo comparison effect. *Journal of Personality and Social Psychology*, 85 (6), 1121-1135.
- [18] Philips, D. (1984). The illusion of incompetence among academically competent children. *Child Development*, 55, 2000-2016.
- [19] Prendergast, C. (1999). The provision of incentives in firms. *Journal of Economic Literature*, 37, 7-63.
- [20] Santos-Pinto, L. and J. Sobel (2005). A model of positive self-image in subjective assessments. *American Economic Review*, 95 (5), 1386-1402.
- [21] Svenson, O. (1981). Are we all less risky and more skillful than our fellow drivers? *Acta Psychologica*, 47, 143-148.
- [22] Van den Steen, E. (2004). Rational overoptimism (and other biases). *American Economic Review*, 94 (4), 1141-1151.
- [23] Zabojnuk, J. (2004). A model of rational bias in self-assessments. *Economic Theory*, 23, 259-282.