



AALBORG UNIVERSITY
DENMARK

Aalborg Universitet

Reliability of Modern Power Electronic-based Power Systems

Blaabjerg, Frede; Peyghami, Saeed

Published in:

2021 23rd European Conference on Power Electronics and Applications (EPE'21 ECCE Europe)

Publication date:

2021

Document Version

Accepted author manuscript, peer reviewed version

[Link to publication from Aalborg University](#)

Citation for published version (APA):

Blaabjerg, F., & Peyghami, S. (2021). Reliability of Modern Power Electronic-based Power Systems. In *2021 23rd European Conference on Power Electronics and Applications (EPE'21 ECCE Europe)* (pp. P.1-P.10). IEEE. <https://ieeexplore.ieee.org/document/9570595>

General rights

Copyright and moral rights for the publications made accessible in the public portal are retained by the authors and/or other copyright owners and it is a condition of accessing publications that users recognise and abide by the legal requirements associated with these rights.

- Users may download and print one copy of any publication from the public portal for the purpose of private study or research.
- You may not further distribute the material or use it for any profit-making activity or commercial gain
- You may freely distribute the URL identifying the publication in the public portal -

Take down policy

If you believe that this document breaches copyright please contact us at vbn@aub.aau.dk providing details, and we will remove access to the work immediately and investigate your claim.

Reliability of Modern Power Electronic-based Power Systems

Frede Blaabjerg, Saeed Peyghami
Department of AAU Energy
Aalborg University
Aalborg East 9220, Denmark
Tel: +45 2129 2454
Email: fbl@et.aau.dk, sap@et.aau.dk

Acknowledgements:

This work was supported by VILLUM FONDEN under the VILLUM Investigators Grant called RELiable Power Electronic-based Power Systems (REPEPS) at the Department of AAU Energy, Aalborg University, Aalborg Denmark.

Keywords:

«Reliability», «Power electronics», «Power System Reliability», «Mission profile», «Modeling», «Model-based Design», «V-shape Model».

Abstract:

This paper introduces a systematic approach based on the V- shaped model-based reliability analysis for design and planning of power electronic-based power systems (PEPS). According to this concept, the system performance is analyzed employing the physics of failure mechanisms in each components of different units in PEPS. This will facilitate optimal and economic design of power converters as well as economic decision-making in planning of PEPS. Moreover, it helps to identify the weakest units and its components that can in turn help in reinforcement planning and spare unit optimization in PEPS. The viability of the proposed approach is illustrated on a DC distribution network and numerical analyses show how the proposed model-based reliability assessment approach can help to do optimal planning and design of future PEPS.

I. Introduction

Green transition has gained increasing interest recently from policy makers all over the world and electrification is one of the pragmatic and efficient approaches to make greener society of the future. New and advanced green technologies are introduced in different energy sectors for different applications. The most important ones are electronic transmission systems, e-transportation, renewable generations, smart homes, and power-to-gas [1]. Thus, the future energy systems are becoming interconnected and dependent on electric power networks. Furthermore, most of the above-mentioned technologies require power electronic converters for energy conversion, thus making power networks more power electronic based power systems (PEPS). As a result, the performance of the energy systems depends on the short- and long-term characteristics of power converters due to the fact that the converters are vulnerable systems [2]–[10].

According to the filed experience, power converters can affect the power systems performance [2], [11], [12]. Depending on the design and control characteristics of the converters, they can enhance or deteriorate the power system performance. Their characteristics are divided into short-term mainly associated with their control and long-term mainly associated with their lifetime and thereby their failures. Control-oriented characteristics can help interoperability of power grids with proper voltage and frequency support. Moreover, it can deteriorate the power grid performance by inducing stability issues. On the other hand, their long-term characteristics are affected by different stressors such as mission profiles, thermal cycling, humidity and vibration, thus causing wear-out failures, which are in turn limiting the end of life of converters. This will affect the power delivery performance in PEPS. The main focus of this paper is on the long-term performance of the PEPS.

There are several solutions to guarantee the desired long-term performance of the PEPS. These solutions are performed at different levels attributed to the characteristics of devices, converters and the power system [13], [14].

At device level, the main goal is to produce high reliable devices, e.g., power devices, capacitors, with a desired life cycle. To do so, physics of failure analysis are adopted to identify the weakest links of each device to reinforce the devices within manufacturing. Moreover, accelerated lifetime tests are performed in order to characterize the lifetime model of the devices to understand the impact of different extrinsic failure stressors under different operating conditions. This lifetime model is employed at the converter level to design a converter for a desired level of reliability [15]–[22] according to its application. Mission profile analysis are employed to map the impact of operating and environmental conditions into the lifetime model of the converter devices. The impact of switching scheme [16], [20], [21], [23], active thermal management [4], [5], reactive power support [17], interleaving conversion stages [24], [25], integrated design [26], age-based maintenance strategies [27], etc. on the converter lifetime have been explored. Furthermore, at the system level, the impact of active and reactive power routing [28]–[31] are employed to enhance the long-term performance of the PEPS.

The aforementioned approaches can be performed at different levels during planning and operation of the PEPS to guarantee its performance. However, in order to have optimized and economic impact on the PEPS performance, these solutions need to be coordinated in a hierarchy from device-level up to system-level. This means, for instance, a solution at device-level may improve the converter reliability but may not have remarkable impact on the power system performance. In this case, the economic achievements at the system-level are not appreciated compared to the cost spent in the device-level. Furthermore, having more reliable unit may not be required from the power system performance stand point. Therefore, it is of high importance to build a hierarchical performance assessment tool for PEPS to map the reliability of devices and converters into the power system performance and vice versa.

This paper aims to introduce a V-shape model-based reliability assessment approach for PEPS using the concept of physics of failure. This approach interconnects the performance of different levels for optimal design and operation of PEPS. This approach will facilitate identifying the weakest units and corresponding devices in the PEPS, based on their functionality in the overall system. Therefore, it will help power converter manufacturers to optimally design the converters for a specific application. Moreover, it aids power system planners to have economic and optimal planning and design of PEPS for a desired life cycle as well as economic planning for maintenance and spare unit optimization in the system. In the following, first the concept of reliability as the main long-term performance indicator in PEPS will be explained in Section II. Then, the proposed model-based reliability assessment tool will be presented in Section III. Section IV will illustrate the viability of the proposed reliability assessment approach for reliable design and planning of PEPS using numerical analysis. Finally, a summary of the paper is provided in Section V.

II. Concept of Reliability in PEPS

Reliability is the measure of the ability of an item or a system to fulfill its functionality under specified conditions within a specified time period [32], [33]. Following this definition, the performance of the system must be preserved within a specified interval for a desired time period as shown in Fig. 1. The performance measures depend on the system/item application. For example, in mission-based applications such as spacecraft, the reliability performance is measured by the probability of survival for the target mission period. Furthermore, in a maintainable/repairable system with the possibility of maintenance such as an automobile, it is important to have the system in the operating state regardless of its failure at the past times. This is measured by the availability metrics, which is defined as the probability of having a system in an operating state at a given instant [33]. According to this definition, the system should be maintained either before failure using a preventive maintenance strategy or after failure using a corrective maintenance approach to retain the system availability at a high value. Moreover, the performance measure can be a physical parameter of the item/system such as the capacitance of a capacitor, in which its drop below 80% of the rate value which indicates a failure.

Notably, the system needs to be designed/planned in such a way that its performance remains inside the defined boundary as shown in Fig. 1. If it goes beyond the acceptable interval, an appropriate maintenance action must be adopted. There are three remedial approaches to retain the system performance including; (i) design of the system with proper sizing of components to guarantee its performance, (ii) prevent a failure occurrence before it reaches the boundary using preventive maintenance approaches, or (3) return the system to the operating mode after a failure by corrective maintenance methods. Different maintenance strategies in PEPS are explained with more details in [27]. Depending on the system function, application and cost of maintenance/failure, an appropriate maintenance strategy can be adopted for a given system to preserve its performance.

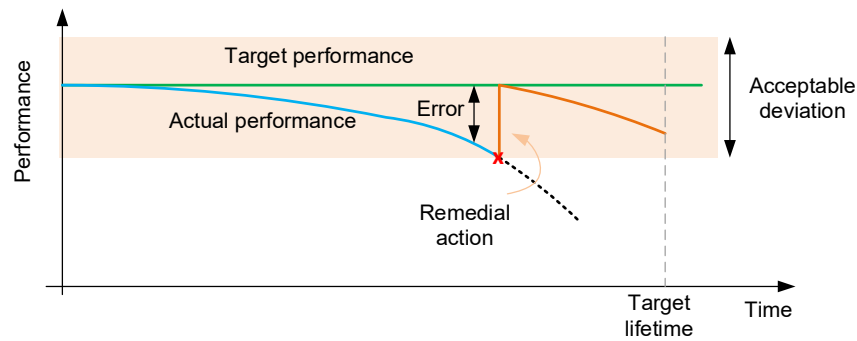

Fig. 1. Definition of reliability as a performance measure in a system or an item. In a reliable system/item, the actual performance remains inside the acceptable boundary either with proper design or by a remedial action whenever it reaches the boundaries.

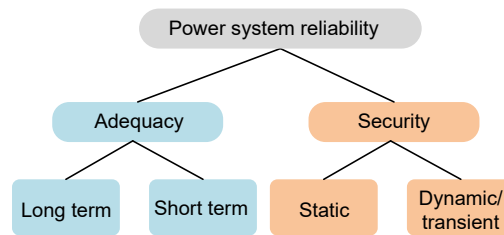

Fig. 2. The concept of reliability in electric power systems including adequacy and security.

Defining the concept of reliability in power systems requires understanding its purpose and function. A power network as a system of systems is aimed to support customers, both consumers and generators evermore. Since it is a complex system, different phenomena can affect its ability to fulfil its goals. These phenomena can happen suddenly during operation. Sudden events such as short-circuit fault, stability issues, large generation/load change are some examples, which happen during operation. These events may have dynamic/transient impact on the system such as rotor angle instability or static impact like overloading of lines. This concept is literally called power system security [34]. In addition to sudden changes affecting the real-time performance of the power system, outage/failure of any components in the power system may cause power shortage in long-term. Thus, the existing power system facilities might not be adequate enough to support the customers. This concept is called adequacy in the power system engineering [34]. Adequacy can be guaranteed by installing/expanding the power network in a long-term, i.e., several years, or by suitable unit commitment and operational planning in a short-term, i.e., a few minutes and several days up to several month. Thus, the power system reliability needs to be explored from a security and adequacy points of view as shown in Fig. 2. Technically, the power system reliability is defined as the measure of its ability to support the customers with acceptable level of power shortage in long-term as well as its ability to withstand sudden changes in short-term in order to guarantee power delivery in the electrical network. Following this definition, the power system facilities must have a specified level of availability to maintain its performance.

One of the popular reliability measures in power systems is load/energy loss [35]. The load loss can be measured by appropriate indices such as Loss Of Load Probability (LOLP), Loss Of Load Expectation (LOLE), Expected Energy Not Supplied (EENS), Energy Index of Reliability (EIR), and so on [33], [35]–[37]. Different countries have specific level of loss of load depends on regulations system operators in each country. For instance, in some European countries, the standard values for LOLE is 4 to 8 hours per year [37]. According to this definition, the failure of some components may or may not impact the power system performance. This is due to the fact the power system is designed with redundant units considering e.g., N-1 or N-1-1 criterion where failure of one, two or more components cannot deteriorate the system reliability. Therefore, in the power system level, the reliability is not defined as the probability of failure but it is a performance measure like the number of hours per year that the grid demand is not supplied. In order to achieve a desired performance level in a power system, the components need to be maintained appropriately to improve their availability rather than the probability of failure. Considering the power system with a combination of different sub-systems and components, the reliability may have different interpretation. At the device level, the probability of failure needs to be taken into account for producing high reliable products. In the sub-system level such as a power converter, the availability is of high importance. Furthermore, in the power system, LOLE or other measures come into account. Depending on the goal of reliability analysis in power system, these different measures might be of interest. Particularly, one measure demands the other based on the existing hierarchy over the function of components and sub-systems in the power system. This requires

systematic reliability evaluation from device-level up to power system-level in order to fulfill the desired performance of the system.

III. V-shape Model-based Reliability Assessment in PEPS

The PEPS is hierarchically made up of three levels including power system, sub-system and component as shown in Fig. 3. In this paper, the sub-systems are limited to power converters, but it can cover all other sub-systems such as transformers and generators. Depending on its application, each converter plays a specified role in power and energy delivery in the PEPS. They are used for interfacing renewable generations, electronic transmission systems, charging station for e-transportation, energy storage, etc. Therefore, their impact on the performance of PEPS is different. Furthermore, a demand for reliability in each converter is dependent on its functionality in PEPS. Moreover, each converter is built up of various components including power devices, capacitors, cooling system, control and protection units. Design and sizing of these components are performed based on the reliability requirements of the converter in the PEPS. Thus, according to the converter function in the PEPS, its reliability level will be defined and then based on this reliability measure, its components will be designed. Therefore, the reliability modeling and assessment as well as enhancement in PEPS need to be carried out in a hierarchy like shown in Fig. 3. This approach is explained in the following sub-sections.

A. Hierarchical reliability modeling and assessment in PEPS

In the modern power networks, power converters are one of the fragile sub-systems, which are also prone to aging failures [2], [3], [38]–[40]. Without losing generality, this section will focus on power converters failure, but the proposed approach is extensible to other sub-systems as well. In power converters, capacitors and power modules are the frequent source of failure [2], [3], [38]–[40]. Their life cycle and reliability depend on operating and climate conditions, i.e., mission profiles. The lifetime of power modules is related to the number of cycles to failure N_f , which is associated with the junction temperature and its fluctuations. The junction temperature is attributed to the operating conditions such as converter loading and the climate condition like ambient temperature and its swing. There are different lifetime models for power devices [2] from different manufactures and for different technologies. Depending on the type of device and model's data availability, a proper model can be employed for reliability evaluation. For instance, the number of cycles to failure, N_f in power devices can be obtained by using [41]:

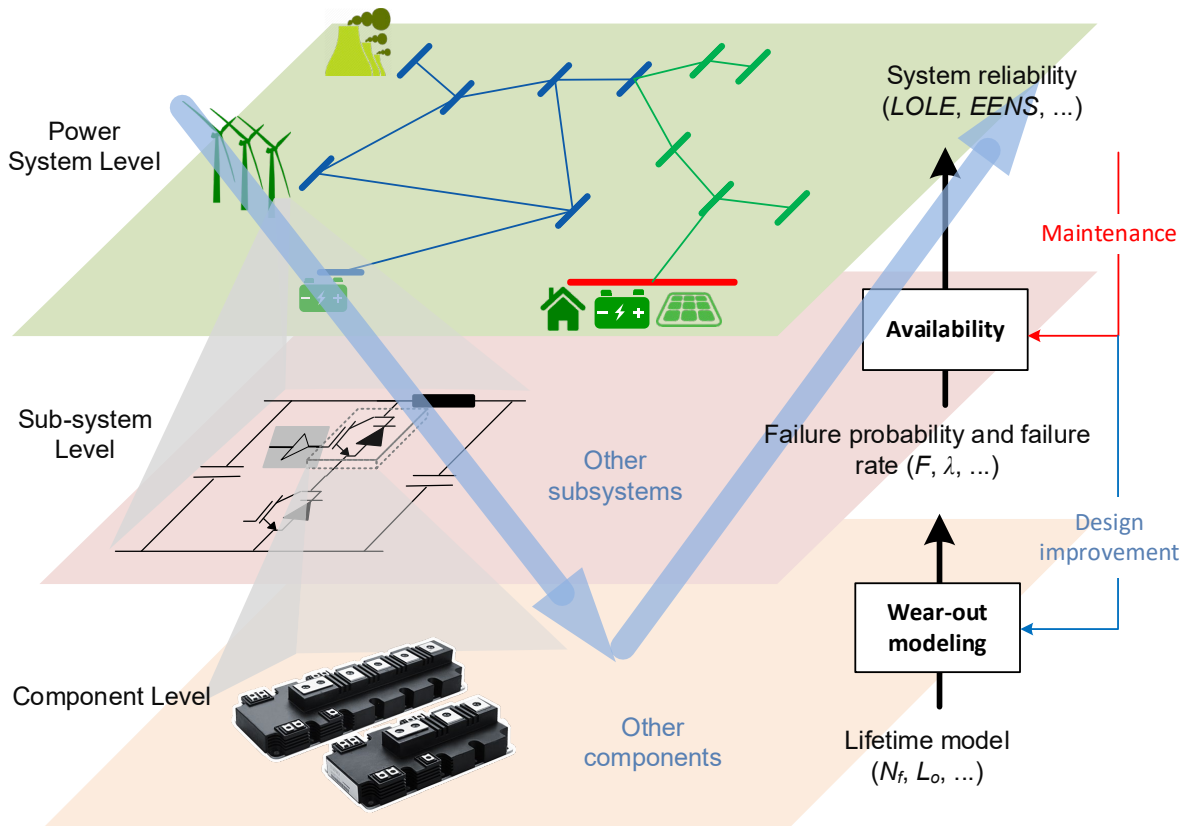

Fig. 3. V-shape model-based reliability analysis in PEPS [14].

$$N_f = A \cdot \Delta T_j^\alpha \cdot \exp\left(\frac{\beta}{T_j}\right), \quad (1)$$

where, ΔT and T are the junction temperature swing and its average value. The constants of A , α , and β are curve fitting constants obtained from aging tests [41]. Furthermore, the lifetime of capacitors can be obtained by [42]:

$$L_o = L_r \cdot 2^{\frac{T_r - T_o}{n_t}} \left(\frac{V_o}{V_r}\right)^{-n_v}, \quad (2)$$

where, L_r denotes the rated lifetime under rated voltage V_r and upper category temperature T_r , and L_o are the capacitor lifetime under operating voltage V_o and temperature T_o . According to (2), the lifetime and consequently, the reliability of capacitors also depend on its voltage and temperature. Both voltage and temperature are associated with the operating condition i.e., loading of the capacitor and the ambient temperature. Notably, more accurate models for lifetime of capacitors and power devices will take into account the vibration, humidity and other stressors, which are important in specific applications.

Since, the lifetime of power devices and capacitors depends on the converter loading, the system level analysis are required to specify the converter operating conditions. Therefore, the first step in the hierarchical reliability modeling shown in Fig. 3 is to perform power flow analysis based on the employed energy management strategy at the power system level. Once the operating mission profiles are determined for each converter, they need to be mapped into the thermo-mechanical domain to obtain the thermal variables, e.g., junction temperature in (1), and capacitor voltage in (2), which are affecting the lifetime of the converter devices. Thus, the second step is to perform electro-thermal modeling in the sub-system level to find the thermal stress on each device. At the device-level, the thermal stresses are assigned to the specific and dominant failure modes in each device. Notably, each device has different failure modes and mechanisms, which need to be modeled by a suitable lifetime model. This paper considers a general lifetime model for each device as given in (1) and (2). However, one can extend the approach considering different failure modes to generate more accurate reliability model. The failure modes of capacitors and power modules are discussed in [43]. The obtained thermal variables in the sub-system level can be used to obtain the consumed lifetime under given mission profile for a given failure mode. To find a time to failure for a given failure mode associated with the given lifetime model in a component, uncertainty analysis needs to be performed. This can be done using stress-strength analysis to obtain the probability of failure for a specific failure mechanism in order to model the impact of manufacturing and model uncertainties on the reliability of component operating under the given mission profile [44]. Thus, the device-level analysis will map the thermal stresses to the reliability and/or failure rate function for each failure mechanism.

After predicting the reliability of devices, the next step is to define the failure rate and availability of the converter based on the failure rate of its components. The availability modeling for converters with different failure modes and types are discussed in [14]. The final step in the PEPS reliability assessment is to combine the availability of converters with the energy availability of prime generation movers and the load profiles. This is to obtain the amount of loss of load/energy due to unavailability of the different components. This step can be performed by coevolving load profile with the generation system model [14], [36]. The result can be reported by a suitable reliability index such as LOLE, EENS, etc.

Fig. 3 shows the proposed V-shaped model-based reliability assessment in PEPS. The first stage is a decomposition of the PEPS to its sub-systems, components and failure modes. Thus, the system is decomposed into sub-systems. In this step the power flow analysis is performed to define the load profile of each converter. Then, the converter is decomposed to the component level. In this step, electro-thermal mapping is performed to identify the stress of devices. Finally, the devices are decomposed to different failure mechanism and failure modes to find the corresponding lifetime associated with the applied stress. The second stage of the proposed V-shape model is the composition of the reliability models from different failure mechanisms of each device up to PEPS. Thus, the failure rate of different failure modes is combined to find the total failure rate of each device. Then, the failure rate of devices is used to model the availability of the converters. Finally, the availability of the converters is convolved with the load model to assess the PEPS performance measured by an index like LOLE, EENS, etc.

B. Model-based reliability enhancement in PEPS

Reliability assessment is usually performed in two cases; first, before system construction for planning and design purposes, and second during operation for reliability enhancement, expansion planning and maintenance planning. The main goal in both cases is to design and operate the PEPS economically by optimal solutions. Once, the system performance is evaluated in both cases, the second step is to check (1) if the reliability level is acceptable, and (2) whether the obtained reliability is economically feasible/attractive. Otherwise, appropriate actions need to be taken to address these issues, which are discussed in the following.

During planning and design of the PEPS, it is required to guarantee the system performance like to have LOLE lower than e.g., 7.5 hours per year. According to the selected devices with the corresponding reliability and failure rates, the LOLE will be evaluated. If it is higher than the desired level, there could be two techniques to preserve it.

- 1) The first one is to reinforce the system's weakest links. Since, the proposed assessment tool is a model-based approach considering the physics of failure mechanism, it facilitates identifying the weakest sub-systems, their weakest components, and the corresponding weakest failure modes. Therefore, power system planner can select high reliable sub-system, here converter, to guarantee the PEPS reliability. Furthermore, the power converter manufacturers can design the converters for a specific application with the demanded reliability by the PEPS planner. In this case, the manufacturers can customize their products, thus more economic and optimal converters can be designed. Having coordination between power system planner and power converter manufactures will increase the proficiency of the whole supply chain.
- 2) The second approach is to keep the system as it has been designed, and plan for replacement of converters at appropriate time periods. Again, since the proposed method is a model-based approach, the PEPS planner can identify the weakest units in the system and its time-dependent impact on the power system. Thus, the planner can plan for suitable number of spare units at proper times for timely replacement of the units to retain the overall PEPS reliability according to the desired performance.

Notably, the first solution is much suitable for systems with limited operation time like a ship, e.g., 20 years. However, electric network is supposed to operate evermore, thus, all of the components need to be timely replaced. Therefore, the second solution is much preferred for electric network like distribution power systems. Defining replacement times and hence designing converters for that time period need to be economically analyzed.

Furthermore, during operation, the system reliability needs to be evaluated as there are various uncertainties affecting the system performance such as unpredicted failure, and aging of units. Thus, the LOLE will be examined every year based on the reliability model and system past performance. If the LOLE goes beyond the desired value, a proper maintenance strategy should be taken in order to retain the system performance. There are various types of maintenance strategies mainly divided into corrective and preventive maintenance [27]. If the impact of a converter on the system performance is negligible, corrective maintenance will be taken. Based on this strategy the converter will be replaced whenever it fails. However, if the converter failure deteriorates the system overall performance, i.e., LOLE, preventive maintenance strategies need to be applied. Preventive maintenance strategies are calendar-based, age-based, and condition-based. They may need different maintenance costs, which are associated with the size of system, failure characteristics, converter functionality in PEPS, etc. Depending on the induced damage on the system due to failure of unit, one of these maintenance approaches will be applied to replace/repair the converter before a failure occurrence.

IV. Numerical Analysis/ Example

This section will present several case studies illustrating the concept of model-based reliability assessment and enhancement in PEPS. First, the concept of reliability assessment and design for reliability will be discussed. Afterwards, the reliability improvement by re-designing the system will be presented. The test system is a DC distribution power network as shown in Fig. 4(a) with an interlinking distribution unit, i.e., grid inverter, Photovoltaic (PV) and Fuel Cell (FC) units. The corresponding converter structures are shown in Fig. 4(b-d) and the specifications of the converters are adopted from [13]. Furthermore, the mission profiles of PV unit and the total load profile are given in Fig. 5.

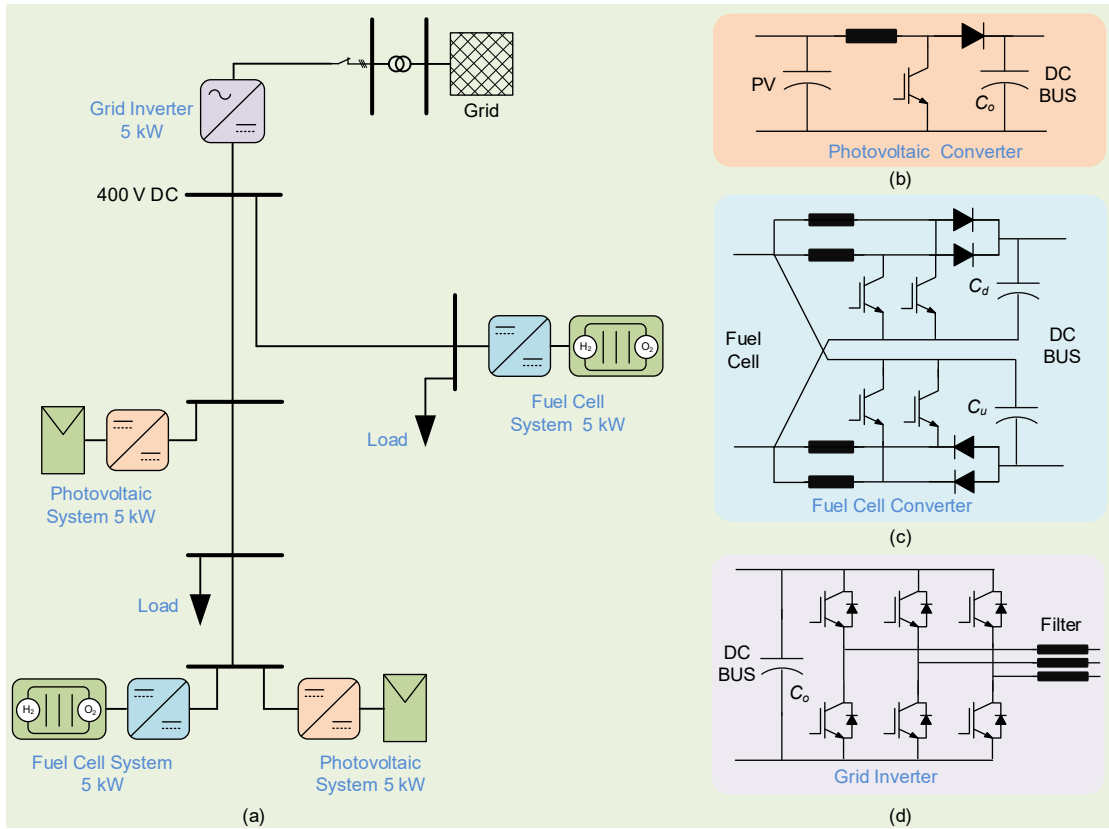

Fig. 4. Structure of DC distribution system; (a) single-line diagram, and (b-d) interface converter structures.

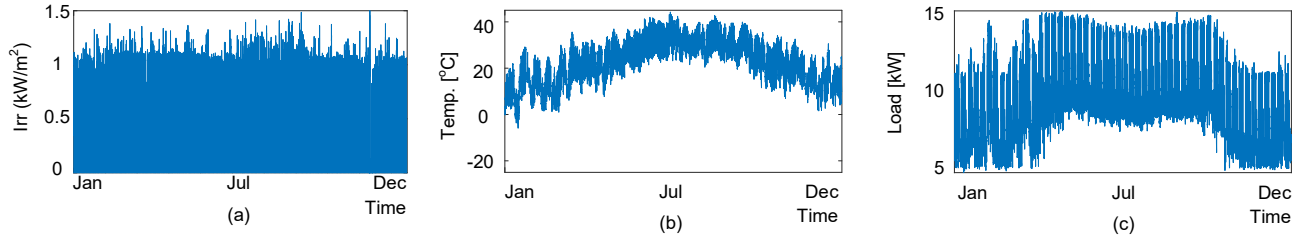

Fig. 5. Mission profiles in the DC distribution system shown in Fig. 4: (a) solar irradiance (Irr), (b) ambient temperature, and (c) accumulated load profile.

A. Reliability assessment and design for reliability

The main goal is to design the DC system in Fig. 4 to guarantee its long-term performance for more than 10 years. To achieve this goal, the reliability of the system is assessed at the first step. The assessment takes into account the power converters as the most failure prone units of the system and other components are considered to have higher reliability. The reliability of converters is obtained using stress-strength analysis according to [44] for the selected devices according to [13]. First, the reliability of fragile components like power devices (IGBT and diode) and capacitors are predicted. Then, the total converter reliability is obtained using reliability network analysis. According to this approach, the PV, FC and grid converters reliability functions are obtained as shown in Fig. 6. It is obvious that the capacitor bank is the dominant component for PV and FC converter, while the grid inverter suffers from poor reliability of power diodes. Furthermore, the B_{10} lifetime, i.e., the period with the probability of failure of 10%, of the converters are 11.1, 13.2 and 15.1 years respectively for PV, FC and grid converters. It seems that from the converter point of view, they can guarantee the main goal of having 10 years of long-term reliable operation. However, it needs to be evaluated by system level measures to examine the system performance.

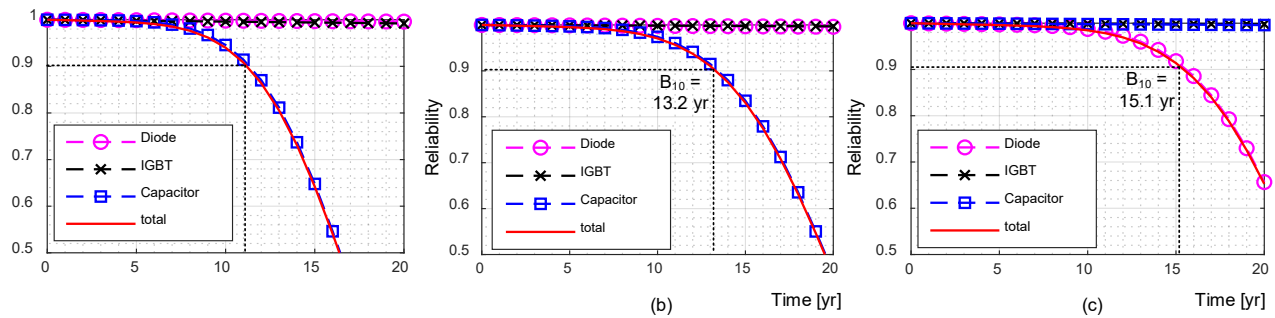

Fig. 6. Reliability function of (a) PV converter components, (b) FC converter components, and (c) grid inverter components.

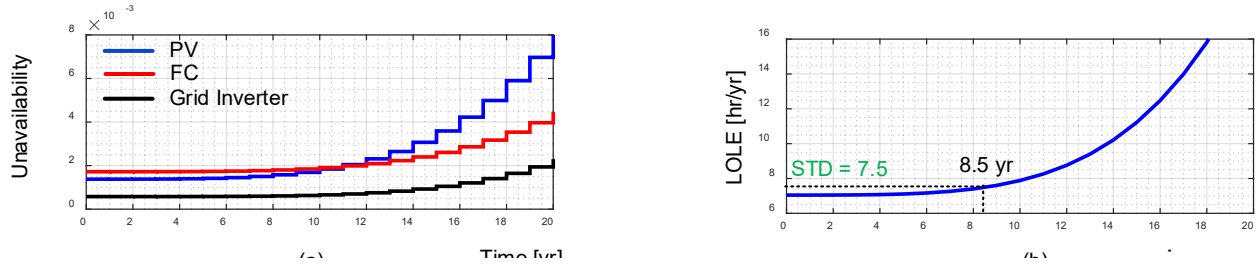

Fig. 7. System reliability performance; (a) converters unavailability functions, and (b) system total LOLE.

Thus, it is of high importance to map the converter reliability into power system reliability. The main measure for the power system reliability is the number of hours per year that the system can supply its demand without power cut that is called LOLE. The LOLE is associated with the power availability, component availability and the load profile. The availability (or unavailability) of the converters is obtained based on their reliability and shown in Fig. 7(a). It is obvious that the aging of converter components increases its unavailability over the operation period. Convolution of these unavailability functions with the availability of solar energy and the load profile given in Fig. 5 will define the system LOLE as shown in Fig. 7(b). The LOLE prediction procedure is explained in [14]. According to Fig. 7(b), the LOLE is increased by the aging of units. If the standard level for LOLE is considered to be 7.5 hours per year, the system become unreliable after 8.5 years. Since, the LOLE is measure annually, then the system needs to be re-designed or maintained by the 8th year of operation. According to these analysis, secure design of a PEPS requires to assess the overall system performance. For instance, the system aims to operate reliably more than 10 years. According to Fig. 6, the converters have B_{10} lifetime of higher than 10 years. However, the system becomes unreliable after 8 years. Therefore, the converter-level measures like B_{10} lifetime cannot guarantee system-level performance. In the next subsection, it is discussed how to use the system-level performance measure for better design of a PEPS.

B. Reliability enhancement and re-design

It is expected that the system to operate reliably more than 10 years, while its reliability is limited to 8 years according to the LOLE index. Therefore, there is two solutions to guarantee desired performance of the system; either replacement of fragile units before entering the 8th year, or redesigning of the system at the beginning. To decide the best solutions the cost will matter. However, for both solutions, it is required to identify the weakest unit and its weakest components. It is not easy to determine the weakest units based on their reliability and/or availability functions. For instance, the PV converter is the weakest unit according to Fig. 6 and Fig. 7(a) as it has the lowest B_{10} lifetime and high unavailability compared to other units. However, as discussed in [45], the FC converter is the weakest unit in the system. Therefore, to guarantee the system reliability over the target period, one can replace the FC converter before the 8th year of operation. Another solution is to reinforce the FC converter from reliability stand point. According to the FC converter reliability shown in Fig. 6(b), the capacitor bank is the fragile link of the converter. It is designed with $5 \times 220\mu\text{F}$ electrolytic capacitors for upper and lower cells of the converter shown in Fig. 4(c). in order to enhance the converter reliability, the capacitor banks are reinforced with $6 \times 220\mu\text{F}$ capacitors. The capacitor banks reliability and the total converter reliability are obtained with the new design as shown in Fig. 8(a). It is obvious that the FC converter reliability is improved compared to the initial design, where the B_{10} lifetime is increased from 13.2 years to 18.1 years. The overall DC system reliability with the new design is shown in Fig. 8(b) implying that the overall system LOLE stays under standard value of 7.5 years with the 12 years of operation. Thus, the desired performance of the system is achieved by the re-design of the system.

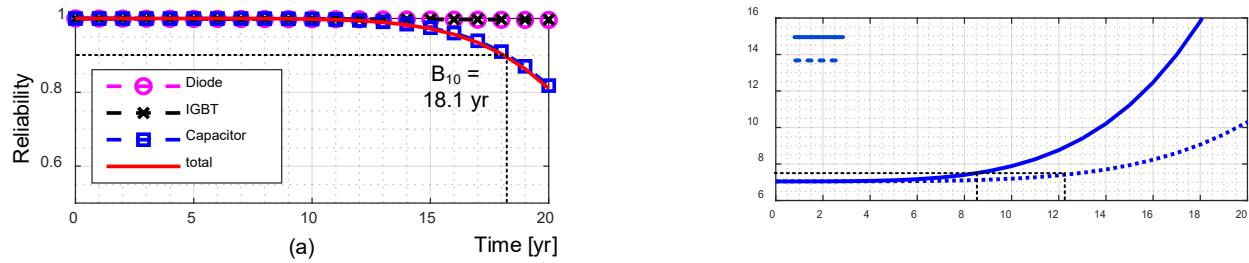

Fig. 8. Impact of FC converter redesign, i.e., redesign of capacitor bank; (a) FC converter components reliability with $6 \times 220 \mu\text{F}$ capacitors in each bank, and (b) total system LOLE with $5 \times 220 \mu\text{F}$ and $6 \times 220 \mu\text{F}$ capacitor bank.

Notably, the analysis in this section is suitable for long-term reliability planning which is of high importance for optimal decision-making for design and operation of PEPS. The proposed model-based reliability assessment tool facilitates optimal design of PEPS and converters for different applications. The converter design with respect to the power system performance provides economically sizing of converter components. For instance, the discussed example showed how reinforcement of capacitor bank of FC converter can improve the overall system performance. Moreover, the proposed V-shape reliability assessment tool facilitate identifying the weakest links and the corresponding weakest components. This will in turn aid the system reinforcement during planning, planning for maintenance during operation, i.e., replacement of the weakest units or the components, and spare unit planning based on the identified weakest components. These are all helping optimal enhancement of the system long-term reliability. The optimal solution could be selected by economic analysis.

V. Summary

Model-based system engineering is a systematic technique for analyzing and design of a system. This concept is adopted in this paper for power electronic based power systems (PEPS). The main goal is to assess the reliability of PEPS considering the physics of failure mechanisms in all devices in each sub-system. The proposed model-based reliability assessment tool facilitates mapping the reliability of the components of each converter to the performance of the PEPS. Thus, optimal design, planning and reinforcement of PEPS can be achieved. Furthermore, the proposed approach can be employed to identify the weakest sub-systems and the corresponding weakest links. This will help power converter manufacturers to design a converter with respect to its application and function in the power system. Moreover, it can be beneficial for power system planners to design PEPS and plan for maintenance of weakest units and plan for required spare units based on the identified fragile components in the system. The concept of model-based reliability assessment is illustrated by an example on a DC distribution system. The future research needs to focus on short-term performance of the system combined with long-term performance to guarantee both security and adequacy of the future power grids with more penetration of power electronics.

References

- [1] H. E. Johan, G. W. Steven, and H. Ramtin, "Third EGrid Workshop Maps the Grid of the Future: Attendees Engage to Examine the Role of Power Electronic Applications in Modern Electric Power Systems," *IEEE Power Electron. Mag.*, vol. 6, no. 1, pp. 48–55, 2019.
- [2] H. S. Chung, H. Wang, F. Blaabjerg, and M. Pecht, "Reliability of Power Electronic Converter Systems," First Edi. London: IET, 2016.
- [3] J. Ribrant and L. M. Bertling, "Survey of Failures in Wind Power Systems With Focus on Swedish Wind Power Plants During 1997–2005," *IEEE Trans. Energy Convers.*, vol. 22, no. 1, pp. 167–173, Mar. 2007.
- [4] K. Fischer, F. Besnard, and L. Bertling, "Reliability-Centered Maintenance for Wind Turbines Based on Statistical Analysis and Practical Experience," *IEEE Trans. Energy Convers.*, vol. 27, no. 1, pp. 184–195, Mar. 2012.
- [5] S. Yang, A. Bryant, P. Mawby, D. Xiang, L. Ran, and P. Tavner, "An Industry-Based Survey of Reliability in Power Electronic Converters," *IEEE Trans. Ind. Appl.*, vol. 47, no. 3, pp. 1441–1451, May 2011.
- [6] X. Liu and S. Islam, "Reliability Issues of Offshore Wind Farm Topology," *Int. Conf. Probabilistic Methods Appl. To Power Syst.*, pp. 523–527, 2008.
- [7] G. J. W. Van Bussel and M. B. Zaaier, "DOWEC Concepts Study, Reliability, Availability and Maintenance Aspects," *Eur. Wind Energy Conf.*, no. July, pp. 557–560, 2001.
- [8] L. M. Moore and H. N. Post, "Five Years of Operating Experience at a Large, Utility-Scale Photovoltaic Generating Plant," *Prog. Photovoltaics Res. Appl.*, vol. 16, no. 3, pp. 249–259, 2008.
- [9] G. Zini, C. Mangeant, and J. Merten, "Reliability of Large-Scale Grid-Connected Photovoltaic Systems," *Renew. Energy*, vol. 36, no. 9, pp. 2334–2340, 2011.
- [10] A. Golnas, "PV System Reliability: An Operator's Perspective," *IEEE J. Photovoltaics*, vol. 3, no. 1, pp. 416–421, 2013.
- [11] "900 MW Fault Induced Solar Photovoltaic Resource Interruption Disturbance Report," 2017.
- [12] IEEE PES-TR 77, "Stability Definitions and Characterization of Dynamic Behavior in Systems with High Penetration of Power Electronic Interfaced Technologies," 2020.

- [13] S. Peyghami, P. Davari, and F. Blaabjerg, "System-Level Reliability-Oriented Power Sharing Strategy for DC Power Systems," *IEEE Trans. Ind. Appl.*, vol. 55, no. 5, pp. 4865–4875, 2019.
- [14] S. Peyghami, F. Blaabjerg, and P. Palensky, "Incorporating Power Electronic Converters Reliability into Modern Power System Reliability Analysis," *IEEE J. Emerg. Sel. Top. Power Electron.*, vol. 9, no. 2, pp. 1668–1681, 2021.
- [15] A. Isidori, F. M. Rossi, and F. Blaabjerg, "Thermal Loading and Reliability of 10 MW Multilevel Wind Power Converter at Different Wind Roughness Classes," in *Proc. IEEE ECCE*, 2012, pp. 2172–2179.
- [16] K. Ma and F. Blaabjerg, "Modulation Methods for Neutral-Point-Clamped Wind Power Converter Achieving Loss and Thermal Redistribution Under Low-Voltage Ride-Through," *IEEE Trans. Ind. Electron.*, vol. 61, no. 2, pp. 835–845, Feb. 2014.
- [17] K. Ma, M. Liserre, and F. Blaabjerg, "Reactive Power Influence on the Thermal Cycling of Multi-MW Wind Power Inverter," *IEEE Trans. Ind. Appl.*, vol. 49, no. 2, pp. 922–930, Mar. 2013.
- [18] Z. Qin, M. Liserre, F. Blaabjerg, and H. Wang, "Energy Storage System by Means of Improved Thermal Performance of a 3 MW Grid Side Wind Power Converter," in *Proc. IEEE IECON*, 2013, pp. 736–742.
- [19] Z. Qin, M. Liserre, F. Blaabjerg, and L. Poh Chiang, "Reliability-Oriented Energy Storage Sizing in Wind Power Systems," in *Proc. IEEE IPEC*, 2014, pp. 857–862.
- [20] Y. Wu, M. A. Shafi, A. M. Knight, and R. A. McMahon, "Comparison of the Effects of Continuous and Discontinuous PWM Schemes on Power Losses of Voltage-Sourced Inverters for Induction Motor Drives," *IEEE Trans. Power Electron.*, vol. 26, no. 1, pp. 182–191, Jan. 2011.
- [21] M. Andresen, G. Buticchi, and M. Liserre, "Study of Reliability-Efficiency Tradeoff of Active Thermal Control for Power Electronic Systems," *Microelectron. Reliab.*, vol. 58, pp. 119–125, Mar. 2016.
- [22] H. Wang, A. M. Khambadkone, X. Yu, Huanhuan Wang, A. M. Khambadkone, X. Yu, H. Wang, A. M. Khambadkone, and X. Yu, "Control of Parallel Connected Power Converters for Low Voltage Microgrid—Part II: Dynamic Electrothermal Modeling," *IEEE Trans. Power Electron.*, vol. 25, no. 12, pp. 2971–2980, Dec. 2010.
- [23] M. Abarzadeh, S. Peyghami, K. Al-Haddad, N. Weise, L. Chang, and F. Blaabjerg, "Reliability and Performance Improvement of PUC Converter Using a New Single-Carrier Sensor-Less PWM Method with Pseudo Reference Functions," *IEEE Trans. Power Electron.*, vol. 36, no. 5, pp. 6092–6105, 2021.
- [24] S. Peyghami, P. Davari, H. Wang, and F. Blaabjerg, "System-Level Reliability Enhancement of DC/DC Stage in a Single-Phase PV Inverter," *Microelectron. Reliab.*, vol. 88–90, pp. 1030–1035, Sep. 2018.
- [25] S. Peyghami, P. Davari, H. Wang, and F. Blaabjerg, "The Impact of Topology and Mission Profile on the Reliability of Boost-Type Converters in PV Applications," in *Proc. IEEE COMPEL*, 2018, pp. 1–8.
- [26] S. Peyghami, P. Davari, H. Wang, and F. Blaabjerg, "System-Level Reliability Enhancement of DC/DC Stage in a Single-Phase PV Inverter," *Microelectron. Reliab.*, vol. 88–90, no. September, pp. 1030–1035, 2018.
- [27] S. Peyghami, F. Blaabjerg, J. R. Torres, and P. Palensky, "Maintenance Scheduling in Power Electronic Converters Considering Wear-out Failures," in *2020 22nd European Conference on Power Electronics and Applications, EPE 2020 ECCE Europe*, 2020, pp. 1–10.
- [28] V. Raveendran, M. Andresen, and M. Liserre, "Improving Onboard Converter Reliability For More Electric Aircraft With Lifetime-Based Control," *IEEE Trans. Ind. Electron.*, vol. 66, no. 7, pp. 5787–5796, 2019.
- [29] S. Peyghami, P. Davari, and F. Blaabjerg, "System-Level Lifetime-Oriented Power Sharing Control of Paralleled DC/DC Converters," in *Proc. IEEE APEC*, 2018, pp. 1890–1895.
- [30] J. Jiang, S. Peyghami, C. Coates, and F. Blaabjerg, "A Decentralized Reliability-Enhanced Power Sharing Strategy for PV-Based Microgrids," *IEEE Trans. Power Electron.*, vol. 6, no. doi: 10.1109/TPEL.2020.3040991, pp. 7281–7293, 2020.
- [31] S. Peyghami, T. Dragicevic, and F. Blaabjerg, "Intelligent Long-Term Performance Analysis in Power Electronics Systems," *Sci. Rep.*, vol. 11, no. 1, pp. 1–18, 2021.
- [32] C. K. Kapur and M. Pecht, "Reliability Engineering," First Edit. New Jersey: John Wiley & Sons, 2014.
- [33] R. Billinton and R. Allan, "Reliability Evaluation of Engineering Systems." New York: Plenum press, 1992.
- [34] S. Peyghami, P. Davari, M. Fotuhi-Firuzabad, and F. Blaabjerg, "Standard Test Systems for Modern Power System Analysis: An Overview," *IEEE Ind. Electron. Mag.*, vol. 13, no. 4, pp. 86–105, 2019.
- [35] R. Billinton and K. Chu, "Early Evolution of LOLP: Evaluating Generating Capacity Requirements [History]," *IEEE Power Energy Mag.*, vol. 13, no. 4, pp. 88–98, Jul. 2015.
- [36] R. Billinton and R. N. Allan, "Reliability Evaluation of Power Systems," First. New York: Plenum Press, 1984.
- [37] M. Čepin, "Assessment of Power System Reliability Methods and Applications." Springer Science & Business Media, 2011.
- [38] F. Spinato, P. J. Tavner, G. J. W. van Bussel, and E. Koutoulakos, "Reliability of Wind Turbine Subassemblies," *IET Renew. Power Gener.*, vol. 3, no. 4, p. 387, 2009.
- [39] J. Carroll, A. McDonald, and D. McMillan, "Reliability Comparison of Wind Turbines With DFIG and PMG Drive Trains," *IEEE Trans. Energy Convers.*, vol. 30, no. 2, pp. 663–670, Jun. 2015.
- [40] K. Fischer, K. Pelka, A. Bartschat, B. Tegtmeier, D. Coronado, C. Broer, and J. Wenske, "Reliability of Power Converters in Wind Turbines: Exploratory Analysis of Failure and Operating Data from a Worldwide Turbine Fleet," *IEEE Trans. Power Electron.*, vol. 34, no. 7, pp. 6332–6344, 2018.
- [41] R. Bayerer, T. Herrmann, T. Licht, J. Lutz, and M. Feller, "Model for Power Cycling Lifetime of IGBT Modules - Various Factors Influencing Lifetime," in *Proc. IEEE CIPS*, 2008, pp. 1–6.
- [42] A. Albertsen, "Electrolytic Capacitor Lifetime Estimation," *JIANGHAI Eur. Electron. COMPONENTS GmbH*, pp. 1–13, 2010.
- [43] S. Peyghami, Z. Wang, and F. Blaabjerg, "Reliability Modeling of Power Electronic Converters: A General Approach," in *Proc. IEEE COMPEL*, 2019, pp. 1–7.
- [44] S. Peyghami, Z. Wang, and F. Blaabjerg, "A Guideline for Reliability Prediction in Power Electronic Converters," *IEEE Trans. Power Electron.*, vol. 35, no. 10, pp. 10958–10968, 2020.
- [45] S. Peyghami, P. Palensky, M. Fotuhi-Firuzabad, and F. Blaabjerg, "System-Level Design for Reliability and Maintenance Scheduling in Modern Power Electronic-Based Power Systems," *IEEE Open Access J. Power Energy*, vol. 7, pp. 414–429, 2020.