

Developments of frequency comb microwave reflectometer for the interchange mode observations in LHD plasma

journal or publication title	Journal of Instrumentation
volume	11
page range	C02009
year	2016-02-03
URL	http://hdl.handle.net/10655/00012804

doi: 10.1088/1748-0221/11/02/C02009



Developments of frequency comb microwave reflectometer for the interchange mode observations in LHD plasma

R. Soga¹, T. Tokuzawa², K. Y. Watanabe^{1,2}, K. Tanaka², I. Yamada², S. Inagaki³, N. Kasuya³, and LHD Experiment Group²

¹*Dept. of Energy Engineering and Science, Nagoya University,
Furo-cho, Chikusa-ku, Nagoya, 464-8601, Japan*

²*National Institute for Fusion Science,
322-6 Oroshi-cho, Toki 509-5292, Japan*

³*Research Institute for Applied Mechanics, Kyushu University,
Fukuoka 816-8580, Japan*

E-mail: soga-ryouta14@ees.nagoya-u.ac.jp

ABSTRACT: We have upgraded the multi-channel microwave reflectometer system which uses a frequency comb as a source and measure the distribution of the density fluctuation caused by magneto-hydro dynamics instability. The previous multi-channel system was composed of the Ka-band, and the U-band system has been developed. Currently, the U-band system has eight frequency channels, which are 43.0, 45.0, 47.0, 49.0, 51.0, 53.0, 55.0, and 57.0 GHz, in U-band. Before the installation to the Large Helical Device (LHD), several tests for understanding the system characteristics, which are the phase responsibility, the linearity of output signal, and others, have been carried out. The in situ calibration in LHD has been done for the cross reference. In the neutral beam injected plasma experiments, we can observe the density fluctuation of the interchange mode and obtain the radial distribution of fluctuation amplitude.

KEYWORDS: microwave reflectometer system; frequency comb; density fluctuation; Large Helical Device

Contents

1. Introduction	1
2. Diagnostics system design	2
3. Results of plasma experiment in LHD	5
4. Summary	7

1. Introduction

In the magnetic confinement plasma experimental devices, the suppression of the deterioration of the high β plasma confinement performance is one of the important issues. Magneto-hydro dynamics (MHD) instability, especially low- n interchange instability, is a cause of the deterioration. The interchange instability leads the phenomenon that the well-closed magnetic flux surface is deformed by the spontaneous magnetic field generated in the plasma. When the MHD instability occurs, the plasma fluctuates depending on the deformation of the magnetic field containers. Therefore, the measurement of plasma fluctuation is important for the study of plasma confinement characteristics. According to studies of MHD theory, the structure of the fluctuation is key information to know the characteristics of MHD instability.

There are several techniques for the plasma fluctuation measurements, such as electrostatic probe, magnetic probe, heavy ion beam probe, beam emission spectroscopy, electron cyclotron emission, soft X-ray, laser scattering, and others. A microwave reflectometer is also utilized to measure the density fluctuation [1-4]. Among other techniques, a microwave reflectometer has some advantages such as the no disturbance method, and has high spatial and temporal resolution and needs only a small access to the plasma. The reflectometer uses the cut-off phenomena between the launching electromagnetic wave and plasma. When the ordinary polarized wave is launched into the magnetized plasma, the wave is reflected back from the corresponding cut-off layer where the electron plasma frequency is equal to the launching frequency. When some frequency components of the microwave launch simultaneously, each frequency component reflects back at each corresponding different cut-off position and gives the radial profile. For these reasons, we have developed a multi-channel microwave reflectometer system in the Large Helical Device (LHD) [5]. In particular, this system uses a frequency comb as a source. Comb generator can output many frequency components simultaneously and it is useful to measure the density fluctuation profile [6]. The previous system consists of Ka-band microwave components, which can measure the electron density range with $1 - 2 \times 10^{19} \text{ m}^{-3}$ [7]. In high β plasma experiment, however, the electron density is usually higher than this density range. According to the MHD theory and prior studies, the $m/n = 1/1$ interchange mode is localized in the edge region in high β LHD plasmas. Here, m and n are poloidal and toroidal mode number, respectively [8]. And the mode reduces the pressure gradient around the resonated magnetic surface [9]. Therefore we upgraded the multi-channel

reflectometer system in the U-band microwave range for measuring plasma regions at higher density.

In this article, first we describe the new U-band microwave reflectometer system utilizing a comb generator in section 2. Before the installation on LHD, several tests have been carried out in order to understand the system characteristics such as frequency characteristics, phase responsiveness and system linearity. In section 3, preliminary plasma experimental results are described. The new system has been designed to study the low-n interchange mode instability: the radial distribution of the density fluctuation can be recovered by extracting the corresponding mode component from the measured signal.

2. Diagnostics system design

Because the displacement magnitude of the cut-off layer is bounded to the magnetic flux surface, it can readily be recovered by analyzing the reflected microwave signal. From the point of view of the radial profile measurements, the number of simultaneous frequencies is important because the number of measuring radial points corresponds to the number of launching frequencies.

The microwave frequency comb reflectometer system in U-band shown in Figure 1 is explained below. A comb generator controlled by the incident signal generator (SG) is used as a multi-frequency source for this system. A comb generator can output the higher order harmonics of the incident wave. Figure 2 shows the example of comb generator output when the

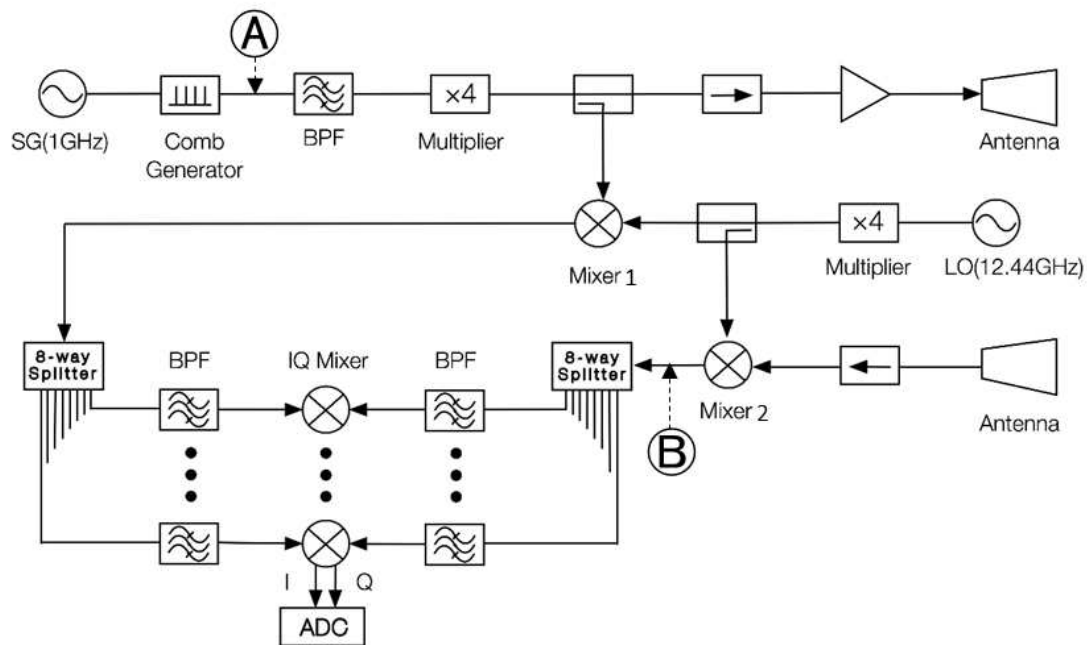

Figure 1. Schematic drawing of U-band microwave reflectometer circuit consisting of a comb generator.

frequency of SG is 1GHz. The frequency comb component is clearly observed every 1 GHz.

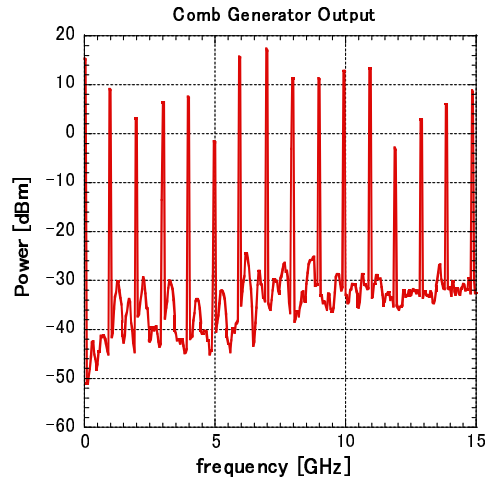

Figure 2. Example of frequency spectrum of comb generator output. This signal is picked up at the point of A in Fig. 1. The stable signal generator (SG) whose frequency is 1 GHz is used as the input source for operating the comb generator.

The frequency range of output reaches to around 20 GHz. The wave is amplified with a band pass filter whose frequency range is 10 - 15 GHz. Then, the wave frequencies are quadrupled by a frequency active multiplier in U-band (40-60 GHz). In the U-band the number of comb components is around 20, when SG frequency is 1 GHz. Therefore, multi-frequency

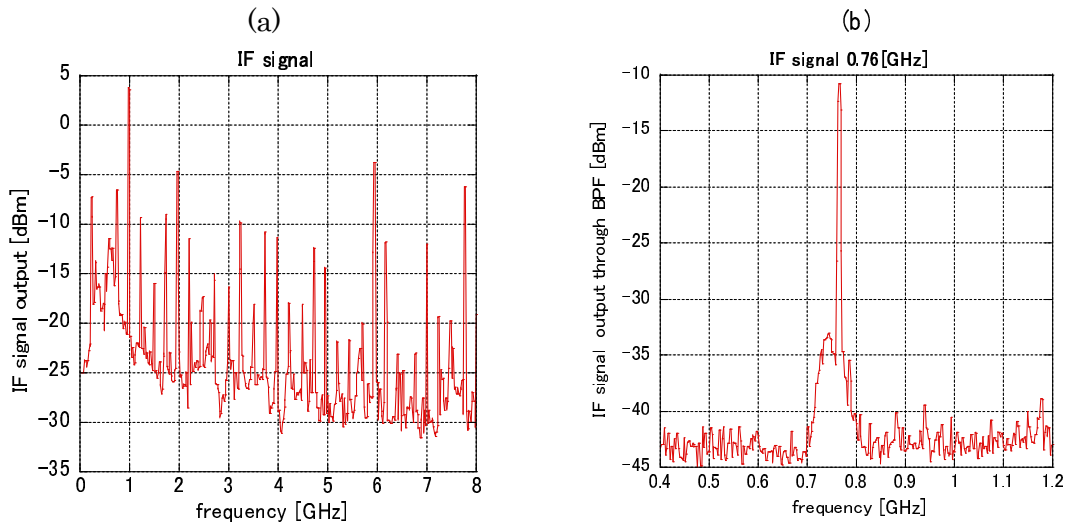

Figure 3. Frequency spectrum of IF signal of (a) the microwave mixer output picked up at the point of B in Fig. 1, and (b) the output of the band pass filter whose center frequency is 0.76 GHz .

components can be launched into the plasma simultaneously. The probe beam is combined with Ka-band frequency component (not shown in Figure 1) and then launched and received by

bistatic conical horn antennae with lenses. The launching angle of the antennae can be modified in the suitable direction according to the plasma specific configuration. The reflectometer signal is mixed with a local wave whose frequency is 49.76 GHz ($= 12.44 \times 4$ GHz). The intermediate frequency (IF) signal, which is the mixer output, has several frequency comb components, as shown in Fig. 3(a).

Part of the probing wave is divided and led to the mixer 1 to make a reference signal for a heterodyne detection. Each IF signal is divided into eight signals by an 8-way splitter. Currently, an eight channel filter bank system is constructed. Center frequencies of band pass filter (BPF) are 0.76, 1.24, 2.76, 3.24, 4.76, 5.24, 6.76 and 7.24 GHz with 200MHz band width. For example, the output of 0.76 GHz BPF is shown in Fig. 3(b). The comb component is found to be 20 dB higher than the noise floor and this frequency component is promising to use in the measurement of the density fluctuation. Each individual wave passing through the band pass filter is led to IQ mixer which outputs two signals with in-phase (I) and quadrature-phase (Q). As shown in Fig. 4, the IQ output shows the circle when the linear phase variation arises. It gives us the information of phase variation caused by the plasma fluctuation. Finally, the PCI-based analog to digital converter (ADC) system with a 1 MHz sampling rate and 16 bits resolution is used for the real-time data acquisition during the whole time of the plasma discharge.

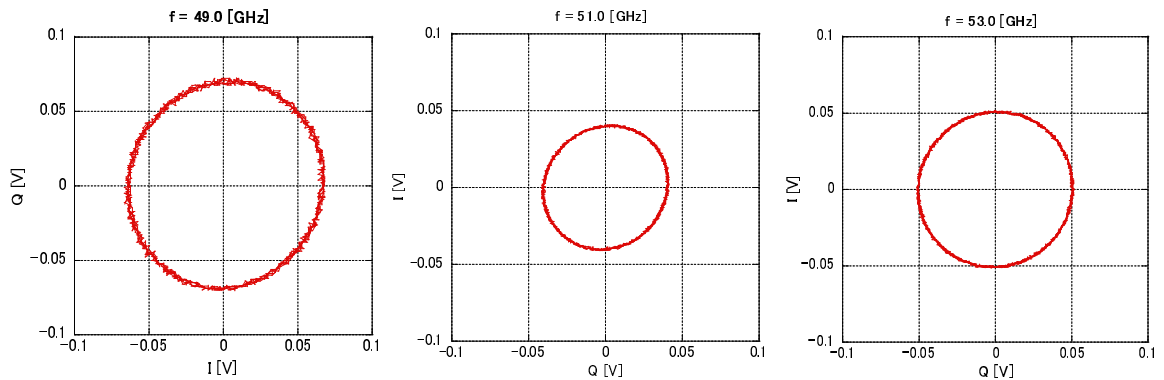

Figure 4. Example of the phasor plot (IQ-plot) of 49.0, 51.0 and 53.0 GHz frequency component

The estimation about the characteristic resolution of this system is explained below. First, the time resolution is 1 μ s. This system is sufficient for measuring the interchange mode instability, because the frequency of low-n interchange mode instability in LHD plasma is usually around 10 kHz or less. Next, the maximum spatial separation of each measurement point is 10 mm when we assume the parabolic electron density profile and its center density is $4.5 \times 10^{19} \text{ m}^{-3}$. This means the spatial resolution is 0.6% with respect to the horizontal radius of the plasma. According to the theoretical simulation, the width of the interchange instability is predicted to be about 5% relative to the horizontal radius of the high-beta LHD plasmas. Thus the system should have the required spatial resolution to measure the interchange instability structure in sufficient details.

The calibration for the fluctuation profile measurement is explained below. The obtained complex reflectometer signal is expressed as $S_j = A_j e^{i\Delta\phi}$, where A_j is the amplitude component of

channel j th, and $\Delta\phi$ is the phase variation of the signal. Now, the value of A_j of each channel would be different as caused by the varieties of frequency characteristics of several microwave components such as amplifier, mixer, and others. Therefore, we have done an in situ calibration of A_j of each channel. When the reflected metal mirror is moved periodically about 60 mm, which round trip time is around 6 sec, the example of temporal behavior of signal I and Q of 49.0 GHz frequency channel is shown in Fig. 5(a). The characteristic amplitude of each channel is obtained simultaneously and it can be used for the comparison with each other. Figure 5(b) shows the extracted phase difference during this test and it is found that the phase change is monotonous according to the change of the reflected position.

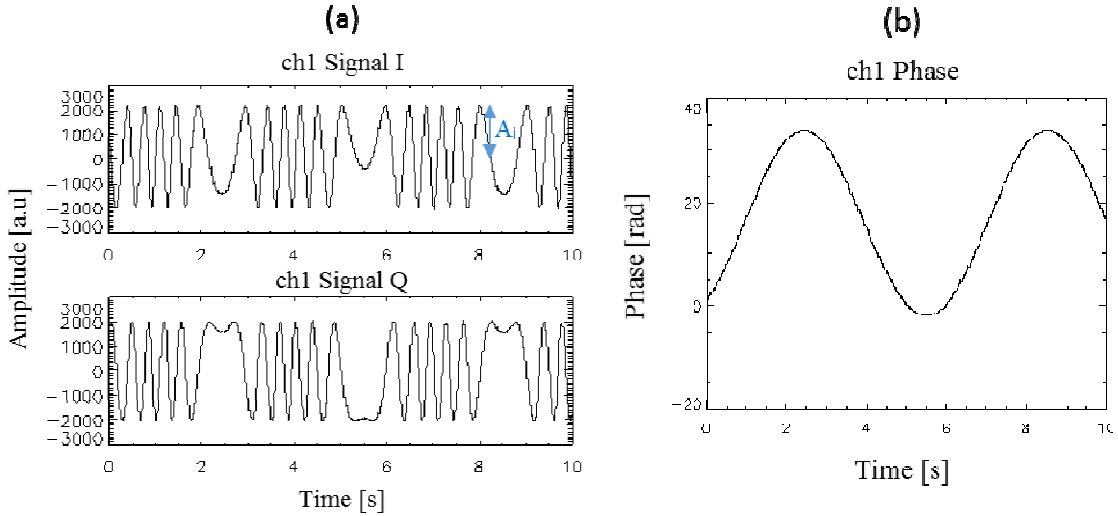

Figure 5. (a) Example of temporal behavior of signal I and signal Q of ch1 (49.0 GHz) and (b) the corresponding phase change in the in situ calibration test.

3. Results of plasma experiment in LHD

The microwave reflectometer system has been applied to the LHD plasma experiment with the condition that the magnetic field strength of the axis is -1.375 T and the magnetic axis position is 3.60 m. In the shot number 129946, the plasma was initiated by ECH from $t = 3.0$ s to $t = 3.5$ s and the additional heating of NBI was injected with almost constant power from $t = 3.5$ s to $t = 12.0$ s. At $t = 9.3$ s, the line-averaged electron density reached to $3.5 \times 10^{19} \text{ m}^{-3}$, as shown in Figure 6(a). Figure 6(c) shows the frequency spectrogram of the signal measured by the microwave reflectometer system of 53.0 GHz. From $t = 5.3$ s, the corresponding cut-off layer appears and several coherent modes can be observed. Around 2 kHz frequency, the component has $m/n = 1/1$ mode structure evaluated by measured magnetic probes and it is considered to be the low- n interchange mode instability. These frequency components are clearly observed also by microwave reflectometer. The complex signal amplitude of this frequency component is calculated on each channel. Then, the extracted radial profile of this density fluctuation amplitude is plotted in Figure 7. Here, the data points do not use only the U-band system but also the Ka-band system. It is observed that this density fluctuation caused by the interchange mode instability localizes around r_{eff}/a_{99} is 0.97 and spreads about 4% of the minor radius.

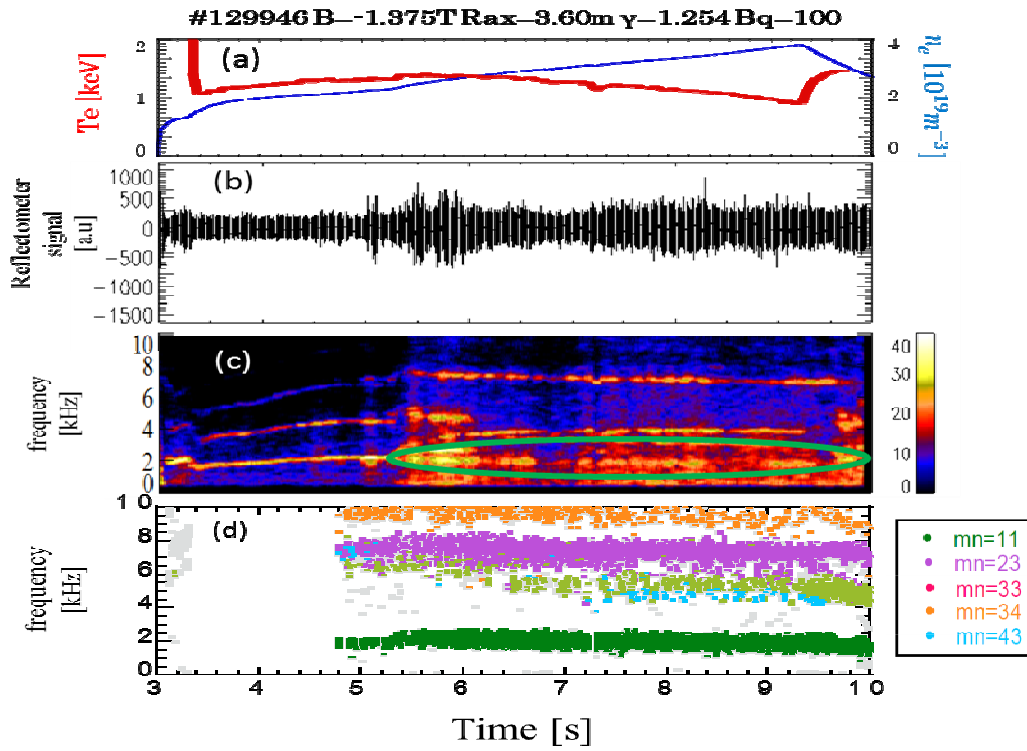

Figure 6. Temporal behavior of (a) the electron temperature (T_e) measured by Thomson scattering system [10] and the line-averaged electron density (n_e) measured by FIR interferometer [11], (b) 53.0 GHz reflectometer signal, and (c) its frequency spectrogram, and (d) magnetic fluctuation decompositions for the mode $(m,n)=(1,1), (2,3), (3,3), (3,4),$ and $(4,3)$ evaluated by magnetic probes signals.

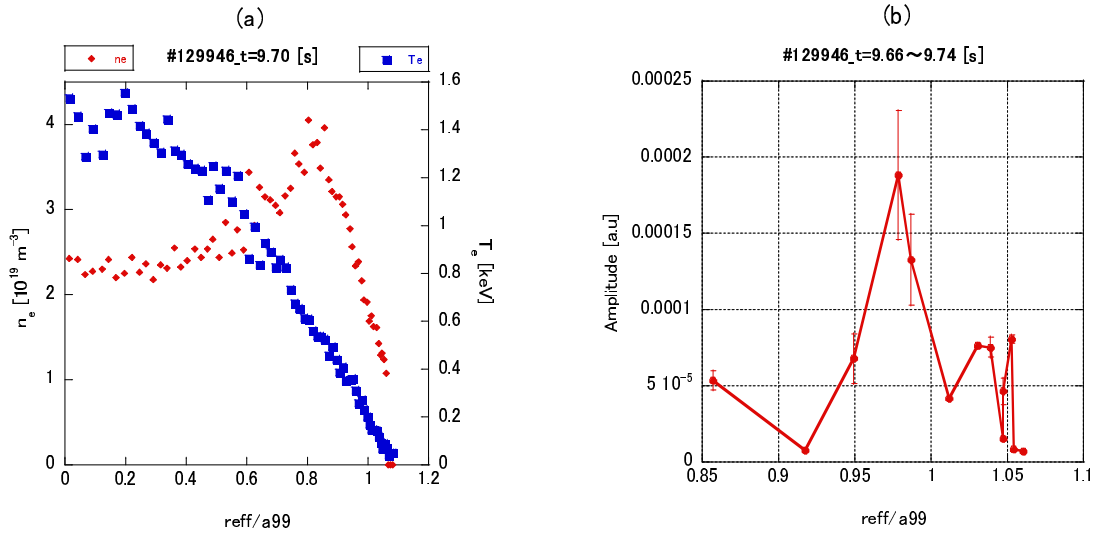

Figure 7. Radial profiles of (a) electron density (n_e) and temperature (T_e) measured by Thomson scattering system, and (b) the density fluctuation amplitude caused by low- n interchange mode instability.

4. Summary

For the study of LHD plasma confinement characteristics, we have newly developed a U-band multi-channel microwave reflectometer system which uses the frequency comb as a source. The characteristics test is carried out for the profile measurement of the density fluctuation before installation to the LHD. This system can measure the density fluctuation of the low-n interchange mode instability in the plasma experiment as a preliminary result. The radial profile of the interchange instability has been evaluated and it is observed that interchange instability is localized and has a spread of about 4% of the minor radius.

Acknowledgments

This work was partially supported in part by KAKENHI (Nos. 25289342, and 26630474). It also was supported in part by the collaboration programs of NIFS and the Joint Research of the RIAM of Kyushu University.

References

- [1] E. Mazzucato, *Microwave reflectometry for magnetically confined plasmas*, *Rev. Sci. Instrum.* **69** (1998) 2201.
- [2] Y. Lin et al., *Upgrade of reflectometry profile and fluctuation measurements in Alcator C-Mod*, *Rev. Sci. Instrum.* **70** (1999) 1078.
- [3] S. Hacquin et al., *Characterization of Alfvén cascades on the JET tokamak using a multi-channel O-mode reflectometer diagnostic*, *Nucl. Fusion* **46** (2006) S714.
- [4] T. Tokzuawa et al., *Observation of Internal structure of energetic particle driven MHD modes in the Large Helical Device*, *Plasma and Fusion Research* **3** (2008) S1064.
- [5] O. Kaneko et al., *Extension of operation regimes and investigation of three-dimensional currentless plasmas in the Large Helical Device*, *Nucl. Fusion* **53** (2013) 104015 .
- [6] W. A. Peebles et al., *A novel, multichannel, comb-frequency Doppler backscatter system*, *Rev. Sci. Instrum.* **81** (2010) 10D902.
- [7] T. Tokzuawa et al., *Ka-band Microwave Frequency Comb Doppler Reflectometer System for the Large Helical Device*, *Plasma and Fusion Research.* **9** (2014) 1402149.
- [8] S. Sakakibara et al., *MHD study of the reactor-relevant high-beta regime in the Large Helical Device*, *Plasma Phys. Controlled Fusion* **50** (2008) 124014.
- [9] K. Y. Watanabe et al., *Effect of pressure-driven MHD instabilities on confinement in reactor-relevant high-beta helical plasmas*, *Phys. Plasmas* **18** (2011) 056119.
- [10] I. Yamada et al., *Recent Progress of the LHD Thomson Scattering System*, *Fusion Sci. Technol.*, **58** (2010) 345.
- [11] T. Akiyama et al., *Interferometer Systems on LHD*, *Fusion Sci. Technol.*, **58** (2010) 352.