

# Journal of STEM Teacher Education

---

Volume 50  
Issue 1 Fall

Article 6

---

2015

## Learning From Student Projects in Logic Design

John M. Mativo  
*University of Georgia*

Shaobo Huang  
*South Dakota School Mines and Technology*

Follow this and additional works at: <http://ir.library.illinoisstate.edu/jste>

---

### Recommended Citation

Mativo, John M. and Huang, Shaobo (2015) "Learning From Student Projects in Logic Design," *Journal of STEM Teacher Education*: Vol. 50: Iss. 1, Article 6.  
Available at: <http://ir.library.illinoisstate.edu/jste/vol50/iss1/6>

This Article is brought to you for free and open access by ISU ReD: Research and eData. It has been accepted for inclusion in Journal of STEM Teacher Education by an authorized administrator of ISU ReD: Research and eData. For more information, please contact [ISURed@ilstu.edu](mailto:ISURed@ilstu.edu).

## **Learning From Student Projects in Logic Design**

John M. Mativo  
*University of Georgia*

Shaobo Huang  
*South Dakota School Mines and Technology*

### **ABSTRACT**

As an introductory course, Logic Design is geared towards familiarizing students with concepts, design, and practical use of digital circuits and systems. Part of the course requirement is for students to form teams and work together to conceptualize and design a digital system that meets an identified need for existing conditions or anticipated futuristic technology. This paper presents student approach to the process of need identification, conceptualization, design, and optimization of a digital system in a term project setting. In conclusion, we discuss lessons learned from student logic design, creativity, and aspirations.

*Keywords:* Computer science; Engineering; Logic design; Technology

The objective of any engineering program is for students to gain the ability to transfer classroom learning to practice for which they will be required to apply knowledge towards problem solving. *Transfer* is a degree of understanding beyond memorization; it indicates the ability to process information and integrate knowledge in new contexts (Mativo & Smith, 2011). Students need to master original information and transfer the knowledge to new applications (Mativo & Smith, 2011; Goldman et al., 2008). Fundamentals of Logic Design is an introductory course at the sophomore level. Topics include digital system and information, combinational logic circuits and design, sequential logic circuits and design, optimization and tradeoffs in design, and physical implementation of design. Course goals include learning logic design concepts and application to solving realistic problems. In this introductory course, students had time to learn the basics of logic design through lecture, assignments, demonstrations, and exams. A term project served as the capstone for students to demonstrate their mastery of the course work.

### **Method**

Dr. Mativo was instructor of the course and collaborated with Dr. Huang to investigate student learning through projects in Logic Design. At the beginning of the course, students were introduced to the fundamentals of logic design, such as gates, truth tables, and logic circuits. State graphs and machines were introduced and used for larger designs with multiple inputs and multiple outputs. In the last few weeks of the course, programmable devices were introduced and used in discussing memory basics. The term project was assigned to students during their 6th week of a 15-week semester. Together with the students, we established a timeline for term project component

completion. These components included identifying the need, conceptualizing and design, optimizing, and presentation. Students were to complete their projects by the end of the semester.

Students were to design a circuit that would serve as a solution to an existing problem or offer a new invention. The engineering design process (EDP), or a variation thereof, was to be followed in this problem-solving exercise. The EDP that students were given included the following steps: establishing the need, developing a problem statement, searching for existing solutions, developing alternative solutions, deciding on a solution, and proposing that solution. Student teams of three to four self-selected members were formed, and teams worked towards a successful completion of their chosen term project.

### Teams

Self-selected teams were formed to provide students with an environment in which to use their acquired knowledge in creative problem-solving ventures with the aim of addressing Accreditation Board for Engineering and Technology (ABET, 2011) Criterion 3: Student Outcomes a, c, e, g, j, and k:

- (a) an ability to apply knowledge of mathematics, science and engineering . . .
- (c) an ability to design a system, component, or process to meet desired needs within realistic constraints such as economic, environmental, social, political, ethical, health and safety, manufacturability, and sustainability . . .
- (e) an ability to identify, formulate, and solve engineering problems . . .
- (g) an ability to communicate effectively (3g1 orally, 3g2 written) . . .
- (j) a knowledge of contemporary issues
- (k) an ability to use the techniques, skills, and modern engineering tools necessary for engineering practice. (p. 3)

### Expectations

Each team was expected to create an invention that addressed an existing need or an anticipated need of the future. The team was to conceptualize and strengthen their initial concept by searching through resources such as literature and patent reviews to establish whether solutions to their identified needs and concepts had already been solved or to gather information that would be helpful in their designs. In the design phase, students were expected to develop a state graph that would help them generate a state table and a Karnaugh map (or maps) as a way to optimize the design. Finally, they were to create a digital circuit and identify hardware that would allow for building a virtual model or a physical model on a breadboard.

In the following sections, three examples of student team self-selected projects, identified as Teams 1, 2, and 3, are presented. It should be noted that we preferred to keep student artwork and writing as original as possible; therefore, any sketch and typographical errors have been preserved. A discussion and conclusion follow these sections.

#### Team 1: Traffic Light Control and Sensor

##### Need

The need was to design a traffic light control device that induces forced vehicle stopping. The team's statement was as follows:

To develop a traffic light control system that allows signals to be transmitted by traffic light and received by an approaching vehicle 20 meters before the light is red. The purpose of the device is to enable the vehicle to come to a stop without running a red light. Once sensors receive signal from traffic light control machine, sensors will press brake automatically for drivers. Current traffic light's countdown system has not prevented drivers from car accidents happened nearby intersection because some drivers are using their phones or doing other things while they are driving. These behaviors make them not able to see traffic light or misunderstand about traffic light so that they might get car accidents by red-running violations. Therefore, we need to develop and modify the current traffic light control system and machine to become better device for drivers' safety.

### Conceptualization and Design

**Search for information.** Through a search of the literature and the patent office, the team found no existing devices or mechanisms similar to the proposed idea. Therefore, the team's approach to finding a solution, as shown below, included developing a problem state, state graph and table, Karnaugh map, and circuit (see Figures 1–3 and Table 1).

#### *Problem State:*

- (i) When the car key is inserted and car gear shift is on D, then X is activated.
- (ii) When car gear shift is on P, then X is deactivated.
- (iii) When the car is approached about 20 meters from traffic control machine, the traffic light control system sends signal to sensor in the car and the car sensor senses a traffic light turning red, then Z is activated.
- (iv) The automatic control system overrides mechanical braking system and slow down car to stop in
- (v) As long as the light is red, then automatic control system is deployed, otherwise it is deactivated.

Table 1

*State Table for Traffic Light Control Circuit*

Present State		Input	Next State		Output
A	B	X	A+	B+	Z
0	0	0	0	0	0
0	0	1	0	1	0
0	1	0	0	1	0
0	1	1	1	0	1
1	0	0	1	0	1
1	0	1	0	0	0
1	1	X	X	X	0
1	1	X	X	X	0

1. S0, X=0, Z=0; Reset, which means that if car key is not inserted, then sensor is deactivated.
2. X=1, Z=0; When driver puts gear shift on D, sensor is activated.
3. S1, X=0, Z=0; When driver puts gear shift back on P, then sensor is deactivated.
4. X=1, Z=1; When car approaches about 20 meters from traffic light control machine at the intersection, traffic light control system sends signal to sensor in the car so that sensor received signal with time for how long is left for traffic light to change from green to red, and then braking system is activated.
5. S2, X=0, Z=1; Since sensor knows when traffic light will change, it does not have to be kept activated while traffic light is changing green to red because braking system takes over to press brake automatically for a car to stop completely.
6. X=1, Z=0; Once traffic light is red, the sensor is activated again. When sensor got signal that traffic light is changed back to green, then the output braking system is deactivated.

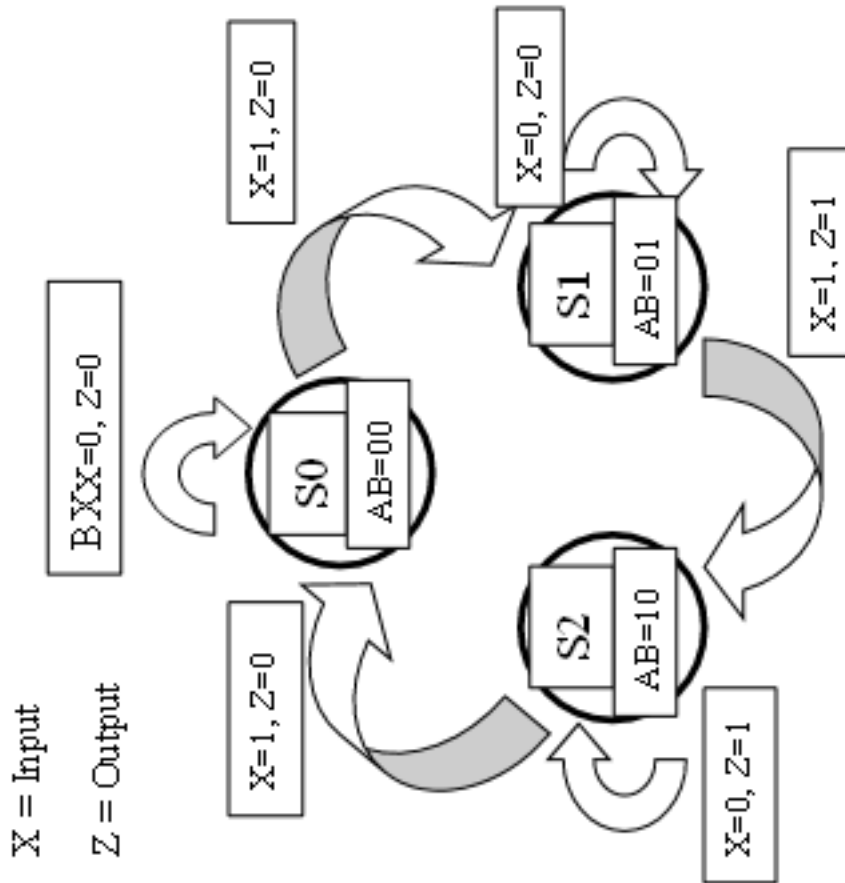

Figure 1. State graph for traffic light control. The box at right shows the stages in the state graph, starting with the top of the graph and moving clockwise

$$Z = A\bar{B}\bar{X} + \bar{A}BX$$

A \ BX	00	01	11	10
0	0	0	1	0
1	1	0	0	0

Figure 2. K-map for Z.

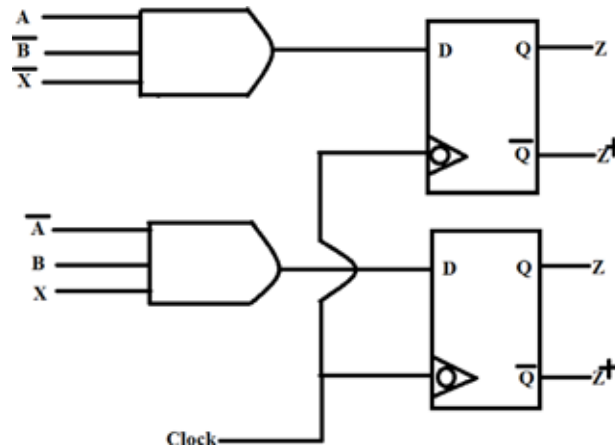

Figure 3. Circuit design for traffic light control circuit.

The optimization process involved developing a Karnaugh map and then algebraically manipulating the results to arrive at the best solution for each case.

**Hardware.** The hardware proposed for this design would include 2 AND Gates (3 inputs each) and 2 D Flip Flops

### Student Summary

The new traffic light control system and sensor are pursued because these machines will protect people's safety and save many things such as money and time from car accidents. Especially, if there is only traffic light control's countdown system and no sensor inside of car, then drivers have a choice to make a decision so that there is a chance for them to get car accidents from making wrong decision when they are about to cross intersection. Since there is the sensor which presses brake automatically when traffic light is about to change, all cars will stop at the moment of the traffic light is changing, so the car accidents would not be happened at the intersection anymore. Therefore, people need to modify current traffic light control system and develop sensor to put all cars to prevent car accidents to protect people's safety and save many things such as money and time.

## Team 2: A Shower Temperature Alarm

### Need

The need was to develop a shower alarm system. The team's statement was as follows:

Knowing instantly when shower water has reached the correct temperature would save time, money, and would be good for the environment. The need for this device stems from a problem shared by many when it comes to taking showers. When the average person starts their shower routine, the first thing they do is turn on the shower. After that, they have to wait for a variable amount of time while the water warms up to their desired temperature; no one wants to get in a cold shower, but no one wants to sit and wait for it to warm up, either—they could be doing other things. The proposed product will need a way to measure water temperature. It will also need a way to know & store the user's desired temperature, a mechanism for alerting them, and a way for the user to interface with the device.

### Conceptualization and Design

**Search for information.** A search for information revealed that the problem is currently not being solved by any external devices, so the team did not have much to go off of or modify. The device design would be able to sound an alarm if the temperature went over a certain threshold (specified in the software). The alarm would stop if the button was held down for 2 seconds. The temperature would be measured by a sensor in the shower head.

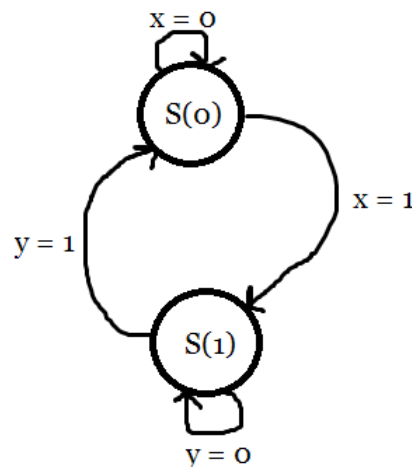

Figure 4. State graph for shower temperature alarm.

In this state graph (Figure 4),  $S_0$  represents the alarm-off state. In this state, the device will be constantly reading the temperature of the shower.  $S_1$  represents the alarm-on state in which the alarm will be beeping. State variable  $x$  is HIGH when temperature is above the threshold and LOW otherwise. State variable  $y$  is HIGH when the button has been held down for 2 seconds, and LOW otherwise.

**Breadboard.** Team 2 built and tested their alarm system based on their state graph. Figures 5 and 6 show their alarm-thermostat circuit design.





Table 2  
Binary Representation of a 3, 4, 1, 6, 2, 5 Car Ejector System Design

Event	A	B	C
Key in ignition	0	1	1
Vehicle in motion	1	0	0
Speed tracking	0	0	1
Impact sensed	1	1	0
Activate car seat eject	0	1	0
Eject car seat	1	0	1

The binary representation above (see Table 2) was developed to show that any sequential or arbitrary design could work for our case. In our case we used an arbitrary state.

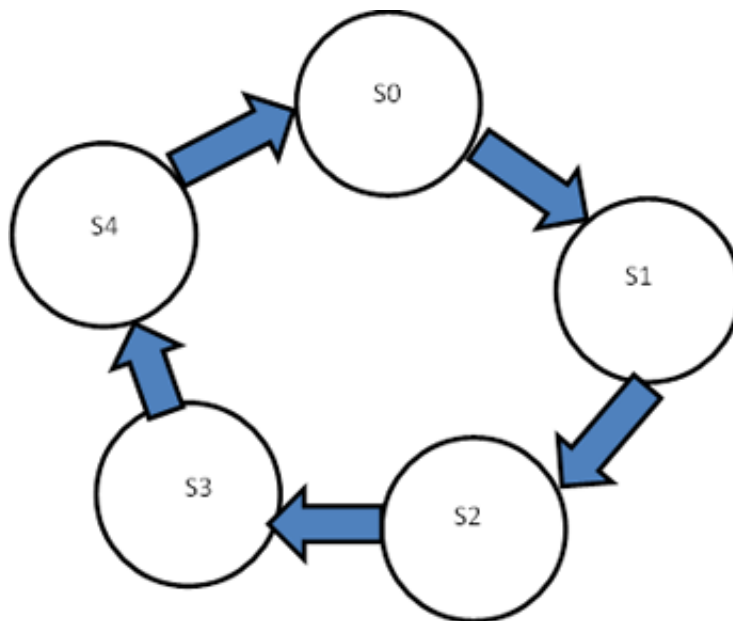

Figure 7. State graph to activate car seat eject

Table 3  
State Table of Car Seat Ejector Design

Present State			Next State		
A	B	C	A <sup>+</sup>	B <sup>+</sup>	C <sup>+</sup>
0	0	0	d	d	d
0	0	1	1	1	0
0	1	0	1	0	1
0	1	1	1	0	0
1	0	0	0	0	1
1	0	1	0	1	1
1	1	0	0	1	0
1	1	1	d	d	d

Note. “d” represents don’t care.

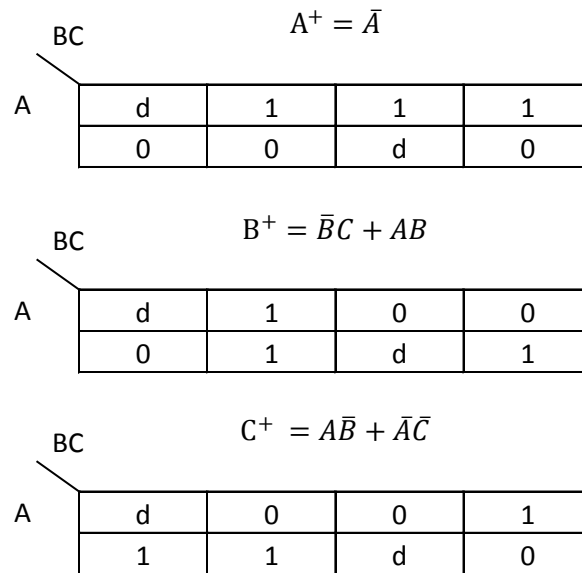

Figure 8. K-maps for  $A^+$ ,  $B^+$ , and  $C^+$ .

**Hardware.** The hardware proposed for this design would include 3 D Flip Flops, 2 two input OR gates, and 4 two input AND gates.

### Student Summary

The proposed design could be implemented to the preexisting technology found on most modern cars. The car possesses four different cameras which cover all angles of the car and have the ability to measure relative speed of objects around the car as well as determine how close an object is. The technology of airbag deployment will be used in the car seat deployment. The design is for an open car without a roof. There are more considerations on the car ejection relative to car design and could be implemented in future cars.

### Other Projects

The project titles not presented in this paper include: DawGone Night Bobber, Automatic Door and Air Conditioning System, and Security Camera Design for special applications. The DawGone Night Bobber provided better fishing rod and line for the night fisher by adding a sensor to the mechanism to indicate whether a large fish or small fish had been caught. Additionally, a light was placed at the bobber to attract fish. The Automatic Door and Air Conditioning System integrated both systems for the prevention of bugs that fly into restaurants. A customer approaching the automatic door would trigger its sensor causing the air conditioning system to turn on acting as an air curtain at the door and effectively keeping bugs away. The Security Camera Design project was designed an advanced image storage system that would enable stored images to be compared to new ones and would notify the operator if there was an anomaly in any of the target areas.

## Discussion and Conclusion

Although this was an introductory course, it showed that students were able to understand logic design concepts and transfer this knowledge to problem solving activities. The time to learn and understand course material was relatively short; however, we believe the time period was sufficient for the introductory course. Lessons learned from this experience include:

1. Students were able to connect course relevance to learning logic design basics from number theory, defining the problem accurately, logic gates, truth tables, digital circuits, state graphs, and programmable devices. By using common logic examples such as calculators, timers, and seat belt illustrations, students were able to associate course material to product design. A sample specific example given in class was an aircraft lavatory where three lavatories were available to the passengers. Each lavatory was equipped with a sensor which would register “1” when occupied and “0” when not occupied. Students were able to develop equations that would allow this to happen. From the equation, they sketched a circuit and were able to see how logic works itself into a physical phenomenon. Further, from their course experience, they were able to transfer that knowledge to providing solutions to problems as exemplified from the three examples presented in this paper. Their ability to use the engineering design method to develop digital circuit that could be incorporate to an existing circuit or as a standalone product is evidence of ability to transfer.
2. Creativity—Students were creative in conceptualizing futuristic needs such as traffic project, shower temperature alarm, intelligent ejector car seat, and more. Authors learned that given time, students armed with logic design can become innovators at a very early stage in their education preparation.
3. Gained confidence—Students were able to present their work in class for not only show and tell but respond to criticisms from their fellow classmates. Some teams realized that their designs were inadequate and needed further attention, while others were ready to develop their ideas into products. A good example work that needed further attention is figure 7 which depicts state graph that lacks an S5 state. Students were able to recognize that during their presentation and were crafty to adjust the figure description, which did not actually solve the problem.
4. A need to provide students with virtual Boolean logic builder and simulator LOGICLY to provide hands-on experiences to students in this course.

Our overall observation was that the term project was an effective way to aid in teaching because it provided a feedback loop that is open to both students and instructor. First, students were required to provide the best possible solution by determining the smallest sum of products having minimal minterms and variables. They learned this process would help them to not only determine the hardware cost and reduced space need but also optimize operation by reducing delays from solutions with unnecessarily more hardware. This activity helped in meeting ABET’s Criterion 3 student outcomes for a, c, and e. Second, at presentation time, students learned to provide scientific/engineering reasons on why they thought their design were better suited to provide solutions for the identified problem. This activity helped satisfy ABET’s Criterion 3 student outcomes for g, j, and k. We observed that introductory courses could benefit students by adding a component of a “capstone” type term project into their courses. This would challenge the student to think beyond just doing well in exams. Further, we believe a rubric to determine

the degree of student achieving in each of the criterion would be helpful in understanding student learning and devise ways to design course for highest attainment.

### References

- ABET. (2011). *2012–2013 Criteria for Accrediting Engineering Programs*. Retrieved from [http://www.abet.org/uploadedFiles/Accreditation/Accreditation\\_Process/Accreditation\\_Documents/Current/eac-criteria-2012-2013.pdf](http://www.abet.org/uploadedFiles/Accreditation/Accreditation_Process/Accreditation_Documents/Current/eac-criteria-2012-2013.pdf)
- Dickinson, T. G. (2001). *Effectiveness of Seat Belts* (SAE Technical Paper No. 840570). Warrendale, PA: SAE International. doi:10.4271/840570
- Goldman, K., Gross, P., Heeren, C., Herman, G. Kaczmarczyk, L., Loui, M. C., & Zilles, C. (2008, March). Identifying important and difficult concepts in introductory computing courses using a Delphi process. *Proceedings of the 39th SIGCSE Technical Symposium on Computer Science Education* (pp. 256–260). New York, NY: Association for Computing Machinery. doi:10.1145/1352135.1352226
- Mativo, J. M., & Smith, N. (2011, June). *Learning in laboratory compliments to lecture courses via student designed and implemented experiments*. Paper presented at the 118th American Society for Engineering Education Conference (ASEE) Annual Conference and Exposition, Vancouver, British Columbia, Canada. Retrieved from <http://www.asee.org/public/conferences/1/papers/731/download>

### Authors

#### John M. Mativo

Associate Professor  
Career and Information Studies & College of Engineering  
University of Georgia  
*Email:* jmativo@uga.edu

#### Shaobo Huang

Assistant Professor, Stensaas Endowed STEM Chair  
Mechanical Engineering  
South Dakota School of Mines and Technology  
*Email:* Shaobo.Huang@sdsmt.edu