

Nonlocal entanglement of coherent states, complementarity, and quantum erasure

Christopher C. Gerry¹ and R. Grobe²

¹*Department of Physics and Astronomy, Lehman College, City University of New York, Bronx, New York 10468-1589, USA*

²*Intense Laser Physics Theory Unit and Department of Physics, Illinois State University, Normal, Illinois 61790-4560, USA*

(Received 27 December 2006; published 21 March 2007)

We describe a nonlocal method for generating entangled coherent states of a two-mode field wherein the field modes never meet. The proposed method is an extension of an earlier proposal [C. C. Gerry, *Phys. Rev. A* **59**, 4095 (1999)] for the generation of superpositions of coherent states. A single photon injected into a Mach-Zehnder interferometer with cross-Kerr media in both arms coupling with two external fields in coherent states produces entangled coherent states upon detection at one of the output ports. We point out that our proposal can be alternatively viewed as a “which path” experiment, and in the case of only one external field, we describe the implementation of a quantum eraser.

DOI: [10.1103/PhysRevA.75.034303](https://doi.org/10.1103/PhysRevA.75.034303)

PACS number(s): 03.67.Mn, 03.65.Ud, 42.65.Lm

A few years ago, a proposal was presented for generating superpositions of various kinds of quantum states of traveling-wave optical fields [1]. The device consists of a Mach-Zehnder interferometer (MZI) coupled to an external traveling-wave field mode through a cross-Kerr medium. With the external field in, say, a coherent state $|\alpha\rangle$, and with a single photon injected into the MZI, the coherent state can be modified depending of the detection of the single photon at one or the other output ports of the MZI. With a cross-Kerr interaction large enough to effectuate a phase shift of π , one can produce various superpositions of the form $|\alpha\rangle + e^{i\theta}|\alpha\rangle$, forms of the so-called Schrödinger cat (quantum superposition) states for a single-mode field [2]. In addition, cat-like states of multimode fields states containing correlations between the modes, such as those for the pair coherent states [3], can also be produced if just one of the field modes is coupled to the interferometer through the cross-Kerr medium. For smaller nonlinearities one can perform “hole burning” in Fock space, i.e., the selective removal of Fock states from the input field [4].

In this paper, we explore the case where the interferometer has cross-Kerr media in both arms and show how single-mode coherent states in two physically separated modes can be entangled even though the modes themselves never meet. The ensuing entanglement is thus of nonlocal origin. Usually, entanglement of photonic states occurs because of the nature of the source, such as the down-conversion process which entangles pairs of photons [5], or because of the action of a beam splitter on nonclassical input field states [6]. The idea of entangling states of objects that do not directly interact is not new. For example, when two separated cavities are prepared in a nonlocal single photon state by the passage through both of a properly prepared atom, then atoms subsequently passing through each of the cavities can become entangled into atomic Bell states [7]. With regard to entangled coherent states, it has been known for some time, from the work of Sanders and Rice [8] that a nonlinear interferometer with a self-Kerr interaction in one arm can be used to unitarily generate entangled coherent states, assuming sufficiently large Kerr nonlinearities. In this case the coherent states to be entangled encounter each other at the first beam splitter of the interferometer. Entangled coherent states have many uses in quantum information science [9]. The proposed

experimental setup can be alternatively interpreted as a “which-path” (welcher-Weg) experiment on the single photon in the interferometer, as we shall discuss below.

The entanglement of two photons that have never interacted has been discussed and experimentally realized by Pan *et al.* [10] in a technique they call “entanglement swapping.” The procedure requires the prior preparation of two sets of EPR-Bohm type states of two polarization entangled photons each. By performing a Bell state measurement involving only one photon from each of the EPR-Bohm states, the other two photons become entangled without interacting. In contrast, our proposal begins with two nonentangled coherent states of possibly large average photon numbers, which become entangled upon a single photon detection as described below. No Bell state measurement is required.

In Fig. 1 we sketch our proposed device. It consists of a Mach-Zehnder interferometer (MZI) containing in each arm cross-Kerr media which are fed coherent states $|\alpha\rangle_a$ and $|\beta\rangle_b$, as indicated. A single photon and the vacuum state, $|1\rangle_c|0\rangle_d$, is fed into the first beam splitter of the MZI, where c and d

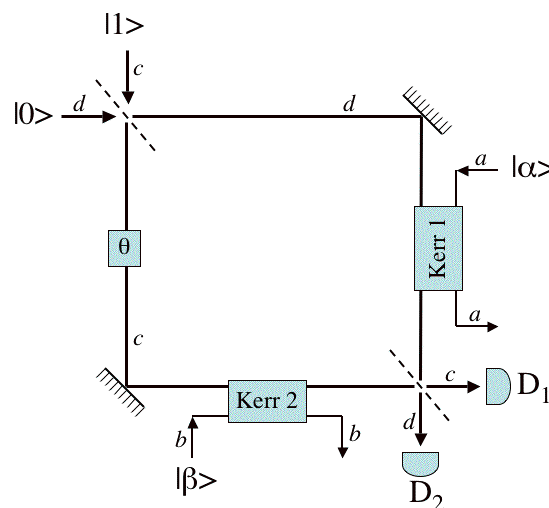

FIG. 1. (Color online) A Mach-Zehnder interferometer, injected with a single photon in the c mode, with cross-Kerr media placed in each arm. The Kerr media are fed coherent states $|\alpha\rangle_a$ and $|\beta\rangle_b$. D_1 and D_2 are the detectors at output.

represent the modes internal to the MZI. The cross-Kerr interaction between the external a mode and the internal d mode in the clockwise path of the MZI is given by $\hat{H}_{\text{CK}(ad)} = \hbar\chi\hat{a}^\dagger\hat{a}\hat{d}^\dagger\hat{d}$. Similarly, the interaction in the counter-clockwise arm coupling the b and c modes is given by $\hat{H}_{\text{CK}(bc)} = \hbar\chi\hat{b}^\dagger\hat{b}\hat{c}^\dagger\hat{c}$. Here, χ is proportional to the third order nonlinear susceptibility, $\chi^{(3)}$, of the medium. The evolution operator for the cross-Kerr interactions is then

$$\hat{U}_{\text{CK}}(\tau_a, \tau_b) = \exp[-i\chi\tau_a\hat{a}^\dagger\hat{a}\hat{d}^\dagger\hat{d}]\exp[-i\chi\tau_b\hat{b}^\dagger\hat{b}\hat{c}^\dagger\hat{c}], \quad (1)$$

where τ_a and τ_b are the interaction times. The phase shift θ in the counter-clockwise beam of the MZI is generated by the operator $\hat{U}_{\text{PS}}(\theta) = \exp(i\theta\hat{c}^\dagger\hat{c})$.

We assume that the input state to our device is given by the product state $|1\rangle_c|0\rangle_d|\alpha\rangle_a|\beta\rangle_b$. After the first beam splitter and the phase shift and just before the cross-Kerr interactions the state of our system is the superposition

$$\begin{aligned} |\psi_1\rangle &= \hat{U}_{\text{PS}}\frac{1}{\sqrt{2}}(|1\rangle_c|0\rangle_d + |0\rangle_c|1\rangle_d)|\alpha\rangle_a|\beta\rangle_b \\ &= \frac{1}{\sqrt{2}}(e^{i\theta}|1\rangle_c|0\rangle_d + |0\rangle_c|1\rangle_d)|\alpha\rangle_a|\beta\rangle_b. \end{aligned} \quad (2)$$

The cross-Kerr interactions produce the state

$$\begin{aligned} |\psi_{\text{CK}}\rangle &= \hat{U}_{\text{CK}}(\tau_a, \tau_b)|\psi_1\rangle \\ &= \frac{1}{\sqrt{2}}[e^{i\theta}|1\rangle_c|0\rangle_d|\alpha\rangle_a|\beta e^{-i\varphi_b}\rangle_b + i|0\rangle_c|1\rangle_d|\alpha e^{-i\varphi_a}\rangle_a|\beta\rangle_b], \end{aligned} \quad (3)$$

where $\varphi_{a,b} = \chi\tau_{a,b}$. The second beam splitter produces the output state

$$\begin{aligned} |\psi_2\rangle &= \frac{1}{2}[e^{i\theta}(|1\rangle_c|0\rangle_d + i|0\rangle_c|1\rangle_d)|\alpha e^{-i\varphi_a}\rangle_a|\beta\rangle_b + (i|0\rangle_c|1\rangle_d \\ &\quad - |1\rangle_c|0\rangle_d)|\alpha\rangle_a|\beta e^{-i\varphi_b}\rangle_b] \end{aligned} \quad (4)$$

or, with some rearrangement,

$$\begin{aligned} |\psi_2\rangle &= \frac{1}{2}[|1\rangle_c|0\rangle_d(e^{i\theta}|\alpha\rangle_a|\beta e^{-i\varphi_b}\rangle_b - |\alpha e^{-i\varphi_a}\rangle_a|\beta\rangle_b) \\ &\quad + i|0\rangle_c|1\rangle_d(e^{i\theta}|\alpha\rangle_a|\beta e^{-i\varphi_b}\rangle_b + |\alpha e^{-i\varphi_a}\rangle_a|\beta\rangle_b)]. \end{aligned} \quad (5)$$

At this point we imagine that a von Neumann state reductive measurement is performed on the output of the second beam splitter. If detector D_1 “clicks,” but not D_2 , signaling the detection of $|1\rangle_c|0\rangle_d$, the a and b modes are projected into the state

$$|\Psi_-(\theta, \varphi_a, \varphi_b)\rangle = \mathcal{N}_-(e^{i\theta}|\alpha\rangle_a|\beta e^{-i\varphi_b}\rangle_b - |\alpha e^{-i\varphi_a}\rangle_a|\beta\rangle_b), \quad (6)$$

whereas if $|0\rangle_c|1\rangle_d$ is detected, the projected state is

$$|\Psi_+(\theta, \varphi_a, \varphi_b)\rangle = \mathcal{N}_+(e^{i\theta}|\alpha\rangle_a|\beta e^{-i\varphi_b}\rangle_b + |\alpha e^{-i\varphi_a}\rangle_a|\beta\rangle_b), \quad (7)$$

where the normalization factors are given by

$$\mathcal{N}_\pm = \frac{1}{\sqrt{2}}\{1 \pm \text{Re}[e^{i\theta}e^{-|\alpha|^2(1-e^{i\varphi_a})}e^{-|\beta|^2(1-e^{i\varphi_b})}]\}^{-1/2}. \quad (8)$$

Thus we obtain rather general entanglements of two coherent states in modes that have never met. In the case of sufficiently large Kerr nonlinearity such that one can have $\varphi_a = \varphi_b = \pi$, we obtain the maximally entangled coherent states

$$|\Psi_\pm(\theta, \pi, \pi)\rangle = \mathcal{N}_\pm(e^{i\theta}|\alpha\rangle_a|-\beta\rangle_b \pm |-\alpha\rangle_a|\beta\rangle_b). \quad (9)$$

For $\theta=0$ and with large $|\alpha|$ and $|\beta|$, these states go over to

$$|\Phi_\pm\rangle \equiv \frac{1}{\sqrt{2}}(|\alpha\rangle_a|-\beta\rangle_b \pm |-\alpha\rangle_a|\beta\rangle_b), \quad (10)$$

which have characteristics of Bell states [11]. Such states could be used for test of local realistic theories against quantum mechanics via violations of Bell’s inequalities, using photonic parity of the quantity to be measured [11]. Such violations would serve to demonstrate the entanglement of the coherent states. Another proposal for using entangled coherent states to violate a Bell’s inequality has been given by Mann *et al.* [12]. Also, one might be able to use the methods proposed by Agarwal and Biswas [13] for the case of pair coherent states.

As already mentioned, there is another way to look at the experimental arrangement sketched in Fig. 1 and that is as a “which-path” experiment on the photon inside the MZI. In fact, Imoto *et al.* [14] already many years ago considered this point of view as an example of complementarity. It was later studied by Sanders and Milburn [15] who considered the case of only a single cross-Kerr medium coupled to an external field mode. As is well known [14,16], the cross-Kerr media with coherent state inputs can perform a true quantum nondemolition measurement on the photon. That is, for the coupling between the a and d modes, with a coherent state in the former and a single photon in the latter, i.e., $|\alpha\rangle_a|1\rangle_d$, again with the interaction governed by $\hat{H}_{\text{CK}(ad)} = \hbar\chi\hat{a}^\dagger\hat{a}\hat{d}^\dagger\hat{d}$, we obtain

$$e^{-i\chi T\hat{a}^\dagger\hat{a}\hat{d}^\dagger\hat{d}}|\alpha\rangle_a|1\rangle_d = |\alpha e^{-i\chi T}\rangle_a|1\rangle_d \quad (11)$$

leaving the photon “undemolished” in its state $|1\rangle_d$. One could then use homodyne techniques to detect the possible phase shift χT of the coherent state. Munro *et al.* [17] have recently discussed a high efficiency quantum-nondemolition (QND) single-photon-number-resolving detector.

From Eq. (5), the probability of measuring the photon in the output state $|1\rangle_c|0\rangle_d$ is given by

$$\begin{aligned} P_{1,0}(\theta, \varphi_a, \varphi_b) &\equiv \frac{1}{4}\left|\left(e^{i\theta}|\alpha\rangle_a|\beta e^{-i\varphi_b}\rangle_b - |\alpha e^{-i\varphi_a}\rangle_a|\beta\rangle_b\right)\right|^2 \\ &= \frac{1}{2}\{1 - \text{Re}[e^{i\theta}e^{-|\alpha|^2(1-e^{i\varphi_a})}e^{-|\beta|^2(1-e^{i\varphi_b})}]\}. \end{aligned} \quad (12)$$

If we set, for simplicity, $\alpha = \beta$ and $\varphi_a = \varphi_b = \varphi$, we obtain

$$P_{1,0}(\theta, \varphi) = \frac{1}{2}(1 - e^{-2|\alpha|^2(1-\cos\varphi)} \cos\theta). \quad (13)$$

The probability of obtaining the other state $|0\rangle_c|1\rangle_d$ is obviously given by

$$P_{0,1}(\theta, \varphi) = 1 - P_{1,0}(\theta, \varphi) = \frac{1}{2}(1 + e^{-2|\alpha|^2(1-\cos\varphi)} \cos\theta). \quad (14)$$

We define the visibility V of the interference fringes according to

$$V = \frac{(P_{1,0})_{\max} - (P_{1,0})_{\min}}{(P_{1,0})_{\max} + (P_{1,0})_{\min}} = \exp[-2|\alpha|^2(1 - \cos\varphi)], \quad (15)$$

from which it is clear that the fringes disappear for large $|\alpha|$ and for $\varphi \neq 0$. Note that the interference fringes are extinguished even though we have not invoked a homodyne measurement on either of the external coherent state beams in order to determine the photon path. The mere potential of obtaining “which-path” information is enough to destroy quantum coherence. Scully, Englert, and Walther [18] considered a which-path experiment involving the Young-type interference of (two-level) atoms that have interacted with a cavity supporting a single-mode resonant field. They showed that a photon emitted by an atom passing through the cavity is enough to destroy the atomic beam interference even if the photon is not detected.

In the preceding we have assumed coherent states of identical amplitude in two external modes a and b . But if the field in the b mode is in a vacuum state, the output state of the second beam splitter would be

$$|\psi_2\rangle = \frac{1}{2}[e^{i\theta}(|1\rangle_c|0\rangle_d + i|0\rangle_c|1\rangle_d)|\alpha e^{-i\varphi}\rangle_a + (i|0\rangle_c|1\rangle_d - |1\rangle_c|0\rangle_d) \times |\alpha\rangle_a]. \quad (16)$$

If we set $\varphi = \pi$ we have

$$|\psi_2\rangle = \frac{1}{2}[e^{i\theta}(|1\rangle_c|0\rangle_d + i|0\rangle_c|1\rangle_d)|-\alpha\rangle_a + (i|0\rangle_c|1\rangle_d - |1\rangle_c|0\rangle_d) \times |\alpha\rangle_a]. \quad (17)$$

We emphasize that this is the state of our system after the second beam splitter before the single photon reaches either of the photodetectors. Let us assume that $|\alpha|$ is large enough such that $\langle -\alpha|\alpha\rangle \approx 0$. Introducing the superposition states $|\psi_{\pm}\rangle_a = (|\alpha\rangle_a \pm |-\alpha\rangle_a)/\sqrt{2}$ we can rewrite Eq. (17) as

$$|\psi_2\rangle = \frac{1}{2\sqrt{2}}\{[(e^{i\theta} - 1)|1\rangle_c|0\rangle_d + i(e^{i\theta} + 1)|0\rangle_c|1\rangle_d]|\psi_+\rangle_a - [(e^{i\theta} + 1)|1\rangle_c|0\rangle_d + i(e^{i\theta} - 1)|0\rangle_c|1\rangle_d]|\psi_-\rangle_a\}. \quad (18)$$

The states $|\psi_{\pm}\rangle_a$ are particular forms of the so-called

Schrödinger cat states [2], specifically the even (+) and odd (−) cat states, meaning that they contain only even or odd photon number states, respectively. Thus if we perform a parity measurement on the a mode and obtain the result “even,” then the c - d modes are projected into the state

$$|\Phi_+\rangle_{cd} = \frac{1}{\sqrt{2}}[(e^{i\theta} - 1)|1\rangle_c|0\rangle_d + i(e^{i\theta} + 1)|0\rangle_c|1\rangle_d], \quad (19)$$

which constitutes a revival of the single-photon interference fringes. The parity measurement erases the “which-path” information and thus we have another example of a quantum eraser [19]. On the other hand, if “odd” parity is detected we project out

$$|\Phi_-\rangle_{cd} = \frac{1}{\sqrt{2}}[(e^{i\theta} + 1)|1\rangle_c|0\rangle_d + i(e^{i\theta} - 1)|0\rangle_c|1\rangle_d], \quad (20)$$

which also results in interference fringes (the “antifringes”), but shifted relative to those obtained from the state of Eq. (19). Of course, to make this work one must find an efficient way of measuring the parity of a traveling wave field. In principle one could simply count photons using, say, avalanche detectors and take note of the evenness or oddness of the counts, though presently this is a challenge as avalanche detection is not yet generally able to resolve photon counts at the level of a single photon. On the other hand, one could use the QND approach [14,16,17] to photon number counting. But instead, one could perform a QND measurement of parity as recently discussed [20] and thus avoid photon counting altogether. Parity measurements on a single-mode cavity field have previously been shown to implement a quantum erasure scheme in the context of a variant of the Scully *et al.* [18] proposal wherein the atoms act dispersively with a cavity field prepared in a coherent state [21]. In that case, the field parity can be detected by a properly velocity selected atom followed by selective field ionization.

Finally, the key for implementing the above proposals, including the quantum nondemolition measurement of parity [20], is the requirement of large nonlinear susceptibility $\chi^{(3)}$. Such do not exist in readily available materials [22]. However, there has been progress in achieving enhanced nonlinearities through the process of electromagnetically induced transparency [17,23], and it seems likely that such will be available in the foreseeable future.

In summary, we discussed a method by which coherent states in modes that never meet can become entangled. Our proposed method can be alternatively interpreted as a “which-path” experiment for a single photon inside a Mach-Zehnder interferometer. Finally, we showed how a quantum eraser can be implemented by performing parity measurements on a traveling wave field.

This research was supported by grants from the Department of the Army, PSC-CUNY, National Science Foundation, and Research Corporation.

- [1] C. C. Gerry, Phys. Rev. A **59**, 4095 (1999).
- [2] See V. Bužek and P. L. Knight, *Progress in Optics*, edited by E. Wolf (Elsevier, Amsterdam, 1995), Vol. 34, p. 1; C. C. Gerry and P. L. Knight, Am. J. Phys. **65**, 964 (1997); *Introductory Quantum Optics* (Cambridge University Press, Cambridge, 2005), p. 174.
- [3] C. C. Gerry and R. Grobe, Phys. Rev. A **51**, 1698 (1995).
- [4] C. C. Gerry and A. Benmoussa, Phys. Lett. A **303**, 30 (2002).
- [5] See, for example, F. De Martini, M. Fortunato, P. Tombesi, and D. Vitali, Phys. Rev. A **60**, 1636 (1999).
- [6] M. S. Kim, W. Son, V. Bužek, and P. L. Knight, Phys. Rev. A **65**, 032323 (2002); W. Xiang-bin, *ibid.* **66**, 024303 (2002).
- [7] C. C. Gerry, Phys. Rev. A **53**, 4583 (1996).
- [8] B. C. Sanders, Phys. Rev. A **45**, 6811 (1992), B. C. Sanders and D. A. Rice, *ibid.* **61**, 013805 (1999). See also, J. C. Howell and J. A. Yeazell, *ibid.* **62**, 012102 (2000); M. Paternostro, M. S. Kim, and B. S. Ham, *ibid.* **67**, 023811 (2003).
- [9] See, for example, S. J. van Enk and O. Hirota, Phys. Rev. A **64**, 022313 (2001); H. Jeong, M. S. Kim, and J. Lee, *ibid.* **64**, 052308 (2002).
- [10] J.-W. Pan, D. Bouwmeester, H. Weinfurter, and A. Zeilinger, Phys. Rev. Lett. **80**, 3891 (1998).
- [11] C. C. Gerry, J. Mod. Opt. **44**, 2159 (1997).
- [12] A. Mann, B. C. Sanders, and W. J. Munro, Phys. Rev. A **51**, 989 (1995).
- [13] G. S. Agarwal and A. Biswas, J. Opt. B: Quantum Semiclassical Opt. **7**, 350 (2005).
- [14] N. Imoto, H. A. Haus, and Y. Yamamoto, Phys. Rev. A **32**, 2287 (1985).
- [15] B. C. Sanders and G. J. Milburn, Phys. Rev. A **39**, 694 (1989).
- [16] F. X. Kärtner and H. A. Haus, Phys. Rev. A **47**, 4585 (1993); H. A. Haus and F. X. Kärtner, *ibid.* **53**, 3785 (1996); J. C. Howell and J. A. Yeazell, *ibid.* **62**, 032311 (2000).
- [17] W. J. Munro, K. Nemoto, R. G. Beausoleil, and T. P. Spiller, Phys. Rev. A **71**, 033819 (2005).
- [18] M. O. Scully, B.-G. Englert, and H. Walther, Nature (London) **351**, 111 (1991).
- [19] A. Peres, Phys. Rev. D **22**, 879 (1980); M. O. Scully and K. Drühl, *ibid.* **25**, 2208 (1982).
- [20] C. C. Gerry, A. Benmoussa, and R. A. Campos, Phys. Rev. A **72**, 053818 (2005).
- [21] C. C. Gerry, Phys. Rev. A **53**, 1179 (1996).
- [22] R. W. Boyd, *Nonlinear Optics*, 2nd ed. (Academic Press, New York, 2003), Chap. 4.
- [23] H. Schmidt and A. Imamoglu, Opt. Lett. **21**, 1936 (1996); D. Petrosyan and G. Kurizki, Phys. Rev. A **65**, 033833 (2002); M. Paternostro, M. S. Kim, and B. S. Ham, *ibid.* **67**, 023811 (2003); J. Mod. Opt. **50**, 2565 (2003); L. Deng and M. G. Payne, Phys. Rev. A **71**, 011803(R) (2005).