

## Configuring foreign market knowledge and opportunity recognition capabilities to predict the performance of export-manufacturing firms

Md Imtiaz Mostafiz<sup>1</sup>, Murali Sambasivan<sup>2</sup>, See-Kwong Goh<sup>3</sup> and Paiman Ahmad<sup>4,5</sup>

<sup>1</sup>Sheffield Business School, Sheffield Hallam University, Sheffield, United Kingdom of Great Britain and Northern Ireland; <sup>2</sup>Department of Management, Thiagarajar School of Management, Madurai, India; <sup>3</sup>Taylor's Business School, Taylor's University, Faculty of Business and Law, Subang Jaya, Malaysia; <sup>4</sup>Business Administration Department, University of Raparin, Sulaymaniyah, Iraq; <sup>5</sup>Komar University of Science and Technology, Kurdistan Region, Iraq

### ABSTRACT

Export-manufacturing firms survive and ultimately succeed when they can accumulate, harvest, and utilise foreign knowledge to better marshal the capabilities to recognise opportunities. Prior studies are replete with a single solution by combining foreign market knowledge (FMK) and firm performance. A shift from contingent theory to the configurational approach suggests that there are multiple solutions available to achieve intended outcomes. Based on the equifinality assumption, we configure FMK in conjunction with opportunity recognition capabilities to predict performance. In total, 382 export-manufacturing firms were investigated by employing fuzzy-set qualitative comparative analysis (fsQCA) and necessary condition analysis (NCA). Salient findings suggest that young firms achieve superior performance from foreign business and institutional knowledge by enhancing opportunity exploration capability, whereas mature firms succeed from internationalisation knowledge and nurturing opportunity exploitation capability. The study is one of which that contributes to the methodology by introducing fsQCA and NCA in the knowledge management literature.

### ARTICLE HISTORY

Received 7 October 2019  
Accepted 13 April 2021

### KEYWORDS

Foreign market knowledge; opportunity exploration capability; opportunity recognition capability; fsQCA; NCA

## 1. Introduction

Accumulating foreign market knowledge (FMK) is a fundamental strategy of international firms (Mostafiz et al., 2019a). From incremental to early internationalisation, all types of firms get enormous benefit from harvesting and utilising FMK (Eriksson et al., 1997; Knight & Liesch, 2016). Over the years, substantial refinement has been done to ameliorate the theorisation of FMK. Prior study conceptualises FMK as an antecedent or a pivotal determinant to international performance (Zhou, 2007). In this conceptualisation, three types of FMK that are foreign business knowledge, institutional knowledge, and internationalisation knowledge get attention (Eriksson et al., 1997). However, most of the studies are firmly based on the contingent theoretical approach of FMK (Mostafiz et al., 2019a), which avoids the assumption of equifinality (Ragin, 2009).

The contingent theory proposes the contextual solution for antecedents or determinants to achieve firm performance (Kearney et al., 2018). Based on this assumption, important antecedent or determinant often gets omitted. For instance, Zhou (2007) has reported the significant negative impact of FMK on born-global speed (p. 289), and the non-significant relationship between FMK and post-

internationalisation firm performance has been highlighted by Musteen et al. (2014). Such results raise the question of the utilisation of FMK. Mostafiz et al. (2019b) emphasise that entrepreneurs must prudently utilise knowledge to identify international opportunity to sustain in the competitive market. On the one hand, FMK facilitates entrepreneurial firms to understand the needs of the consumer, increase the ability to deal international contracts, and manage international operations; on the other hand, all these entrepreneurial actions are critical inputs to opportunity recognition capabilities (Kraus et al., 2017). If both FMK (Mostafiz et al., 2019a) and opportunity recognition (Mostafiz et al., 2019b) separately are critical success factors to the firm's international performance, then the configuration of FMK and opportunity recognition capabilities will provide superior performance benefit to the export-manufacturing firms.

Opportunity recognition capabilities are the primitive and pivotal capabilities of entrepreneurial firms (Kraus et al., 2017). It is seen as the lynchpin of entrepreneurial firms. As Shane and Venkataraman (2000) promise, opportunity recognition is a process of identifying, discovering, and recognising potential opportunities to create economic value. One of the long-standing questions in the literature is 'where do

**CONTACT** Md Imtiaz Mostafiz  i.Mostafiz@shu.ac.uk;  Sheffield Business School, Room 7327, Stoddart Building, City Campus, Sheffield Hallam University, Sheffield, UK.

© 2021 The Author(s). Published by Informa UK Limited, trading as Taylor & Francis Group.

This is an Open Access article distributed under the terms of the Creative Commons Attribution-NonCommercial-NoDerivatives License (<http://creativecommons.org/licenses/by-nc-nd/4.0/>), which permits non-commercial re-use, distribution, and reproduction in any medium, provided the original work is properly cited, and is not altered, transformed, or built upon in any way.

the opportunities to create goods and services in the future come from?” (Venkataraman, 1997, p. 122). Two capabilities are required to shape opportunity recognition as the firm’s opportunity exploration capability and exploitation capability (Benitez et al., 2018). The exploration refers to the identification of new markets and discovering additional needs of the consumers, whereas exploitation refers to the improvisation of existing product/service offerings (Lubatkin et al., 2006). In three ways, the concept of opportunities are integrated into the management literature; first, as a behaviour of the entrepreneurial firms (Zahra et al., 2005); *second*, as antecedents to achieve the strategic objective (Kontinen & Ojala, 2011); and *third*, organisational configuration (George et al., 2016). In this study, we theorise opportunity recognition capabilities as organisational configuration. A search of primary knowledge management, entrepreneurship, and general management journals suggest that this study is one of the first attempts to advance knowledge management and entrepreneurship literature. This is done by introducing equifinality theorisation and propounding that opportunity recognition capabilities are the backbone of the organisational configuration which are generated from various types of FMK to create competitive economic outcomes. Entrepreneurs identified and acquired FMK through available secondary resources, and some may have extensive tacit knowledge from their previous internationalisation activities. The ability of these entrepreneurs to leverage and apply knowledge acquired may influence the economic outcomes of the firm. To date, both FMK (Mostafiz et al., 2019a; Musteen et al., 2014) and opportunity exploration and exploitation capabilities (Benitez et al., 2018) have been treated as antecedents to a firm’s performance, and the alignment between FMK and opportunity recognition capabilities through configuration has been largely overlooked. Thereby, to fill the research gap, and address *when*, *why*, and *how* foreign knowledge is harvested and utilised as input to the opportunity recognition capabilities in achieving superior performance, we ask: (a) *how do FMK and opportunity recognition capabilities configure to form pathways to performance success?* (b) *Do all types of firms (young vs mature) benefit from the common configurational combination of conditions?*

To answer, we bring together the contingent and configurational theoretical approach to bridge FMK (Eriksson & Chetty, 2003; Eriksson et al., 1997; Mostafiz et al., 2019a; Musteen et al., 2014) and opportunity recognition capabilities (Bhagavatula et al., 2010; Kraus et al., 2017; Lumpkin & Lichtenstein, 2005; Mostafiz et al., 2019b) to achieve performance success. We apply *fuzzy-set qualitative comparative analysis* (fsQCA) to acknowledge the unexplored and undocumented interplay of FMK and opportunity

recognition capabilities to determine whether equifinal configurational combinations exist (i.e., *sufficiency*) as multiple and alternative routes to complement the firm performance. In fact, to offer an in-depth understanding of the conditions by investigating “*necessity*”, we employ *necessary condition analysis* (NCA) within the complex context of an emerging economy (Dul, 2016a, 2016b). Theoretically, it is essential to study the interplay as both FMK and opportunity recognition capabilities provide competitive advantages. However, we propound that the combinations and the necessities differ based on firm age. The benefits or the costs of leveraging FMK and opportunity recognition capabilities are not similar in all types of firms. Mature firms can get performance benefit differently than young firms based on the experiences in accumulating FMK and nurturing opportunity recognition capabilities, which have not been dealt with in knowledge management and entrepreneurship literature, previously (Bandera et al., 2016). The interplay of FMK and opportunity recognition capabilities is not a singular process (Mostafiz et al., 2019a). If the performance benefit varies between young and mature firms, only equifinality theorisation can address this research problem (Hughes et al., 2017). Hence, our study contributes to the knowledge management and entrepreneurship literature in three ways. Using the data from an emerging economy, we investigate 178 young, and 194 mature firms<sup>1</sup> that are operating in the apparel industry of Bangladesh. First, our study contributes to the knowledge management literature by conceptualising FMK as a configurational input to opportunity recognition capabilities of the firm. Our study claims that entrepreneurial firms’ success lies on the effective configurations of various types of foreign knowledge, and how well this knowledge can be harvested and utilised as an input to firm’s ability to effectively explore and exploit international opportunities and secure sustainable performance. Second, applying the assumption of equifinality, our study theoretically argues and empirically shows that young firms get performance success differently from mature firms by analysing multiple configurational combinations (i.e., *sufficiency*) and proposes necessary conditions (i.e., *NCA*) to complement performance success rather than a stand-alone solution. Our study contributes to the knowledge-based theory by explaining how differently knowledge decomposes to build opportunity recognition capabilities of the firm to thrive in the international market. Our study advances the knowledge management literature by demonstrating various benefits of FMK in conjunction with opportunity exploration and exploitation capabilities of the firm that are advantageous to performance. Third, unlike prior studies that predominantly apply reductionist bivariate analysis in the knowledge management literature concerning

entrepreneurship (Paoloni et al., 2020), our study embraces equifinality and applies *fsQCA* (Hughes et al., 2017). Because reductionist bivariate analysis often causes unsupported hypothesis and important determinants to firm success get omitted (Woodside, 2014). The *fsQCA* prioritises context-specific combination of conditions and offers nuanced insights between the relationship of predictor and outcome variables (Hughes et al., 2017). In addition, our methodological contribution to the knowledge management literature is not only limited to the sufficiency (*fsQCA*) but also incorporates necessary conditions (NCA) that are essential for entrepreneurial firms while prioritising configurations of FMK and opportunity exploration and exploitation capabilities to secure firm performance.

## 2. Theoretical development and configurations

### 2.1. Foreign market knowledge

FMK is an integral success factor for firms undertaking international operations (Mostafiz et al., 2019a). Eriksson et al. (1997) have proposed three types of FMK, which are (a) foreign business knowledge, (b) foreign institutional knowledge, and (c) internationalisation knowledge. Foreign business knowledge refers to the knowledge of the actions taken by competitors, foreign market needs, distribution channels, and marketing activities (Zhou, 2007). Institutional knowledge refers to foreign business laws and regulations, government agencies, languages and norms (Musteen et al., 2014). Finally, internationalisation knowledge is all about firm's foreign experience, dealing with overseas consumers, and managing international operations (Mostafiz et al., 2019a). Both knowledge-based view (Grant, 1996) and organisational learning (Gil & Carrillo, 2016; Huber, 1991; Levinthal & March, 1993; March, 1991) have been adopted to theorise FMK in management literature. The theorists of the knowledge-based view proffer that firms must accumulate FMK continuously to be competitive in the market (Mostafiz et al., 2019a). Whereas the organisational learning theorists propound that firms must learn from the foreign market to become innovative, proactive, and develop new revenue streams to sustain in the competitive market (Mudambi & Zahra, 2007; S. Zahra et al., 2001; Zahra et al., 2000). FMK facilitates firms to accumulate information and experiment to create the knowledge-stock of the organisation (Anders Paarup, 2006). Mostafiz et al. (2019a) propose that social network and the cognition refine the firm's ability to accumulate FMK. It is a continuous learning process of the firm to undertake various strategic actions in response to the market stimuli (Cantwell & Mudambi, 2005). Notwithstanding, both the

knowledge-based view and organisational learning theory are contingent theories that do not consider the assumption of equifinality.

Equifinality theorists acquiesce to *configuration theory* and confer the presence of equifinal configurational paths of conditions that may exist as multiple routes to the desired outcome (Drazin & Van De Ven, 1985; Meyer et al., 1993). Entrepreneurial studies suggest that the assumption of equifinality can produce a more meaningful, productive and context-specific business model to determine firm performance (Kearney et al., 2018). Interactions among strategic actions and determinants to firms' performance are more appealing than direct causal effects. For instance, drawing upon contingent theoretical perspective, Musteen et al. (2014) and Zhou (2007) report the unexpected impact of FMK on the outcomes. This happens because contingent theory embraces reductionist symmetrical analysis (Drazin & Van De Ven, 1985) that overlooks equifinal effects. Organizational phenomenon amidst being complex has coupled a lot of information, and reductionist theoretical perspective often let this information lost, thereby omitting critical strategic determinants (e.g., FMK). On the contrary, configurational theorists prioritise small changes in the organisational phenomenon, context, firms' age, size, and other abilities, which might significantly impact organisational growth (Fiss, 2011). Therefore, multiple components or strategic determinants are required to investigate the firm's process, activities, abilities, and performance rather than examining them in isolation (Meyer et al., 1993). We opine that entrepreneurial firms thrive depending upon how well they configure FMK and opportunity recognition capabilities to achieve performance success. These configurations differ depending on the firm size as mature firms have affluent knowledge-stock (Gkypali et al., 2015) and presumably higher opportunity recognition capabilities than young firms (Zahra et al., 2005). Additionally, our study has also scrutinised for the necessary condition to merit profound insights to these configurations. Put simply, we unpack the benefits (or costs – if any) of capitalising FMK and leveraging opportunity exploration and exploitation capabilities for both young and mature firms to complement performance by acquiescing equifinality.

### 2.2. Opportunity recognition capabilities

The promise of entrepreneurship research stresses the need to deepen the understanding of opportunities and their sources (Venkataraman, 1997). Cohen and Winn (2007) define opportunity recognition capabilities as the firm's abilities to "perceive opportunities to existing when there is a potential to redistribute resources for the betterment of some without making others worse off" (p. 32). It is

a process to match emerging consumer demand and the solution to satisfy the necessity (O'Connor & Rice, 2001). Two schools of thoughts as neoclassical equilibrium theory and Austrian theory provide the premium to opportunity recognition capabilities in the entrepreneurship literature. The neoclassical equilibrium theory assumes that an individual who possesses high-risk propensity in recognising the opportunity is considered an entrepreneur (Khilstrom & Laffont, 1979). However, the neoclassical equilibrium theory overlooks the entrepreneurship framework, sources, and the existence of opportunities (Eckhardt & Shane, 2003). Notwithstanding, Austrian theorists argue that opportunities appear from the imperfect market with information asymmetry in a scattered form (Venkataraman, 1997). In a similar vein, Kirzner (1997) emphasises that the influx of knowledge in the market influences opportunity discovery, and only a few entrepreneurs are able to recognise it. Based on this notion, Wang et al. (2013) probe that the firm's opportunity recognition depends highly on the willingness and ability of the firm to discover and create the benefit of it. Entrepreneurs can pursue an opportunity at any time in any industry (Mostafiz et al., 2019d). Aforementioned, opportunities can be derived from uncertainties; however, it is also possible that opportunities appear from circumstances of the needs of new products, services, or business (i.e., knowledge) (Barringer & Ireland, 2008). Timmons and Spinelli (2006) emphasise market opportunities which are meant to be focused on market demand as they increase the chances of success. Therefore, three inherent characteristics of an opportunity are as follows: (a) economic value, (b) newness (i.e., in some cases incremental), and (c) desirability and feasibility (e.g., acceptability of the product/service in the market) (Baron, 2006).

Two fundamental capabilities are promised to effectuate the opportunity recognition of the firms as (a) opportunity exploration capability and (b) opportunity exploitation capability. Opportunity exploration capability is the firm's ability to facilitate scanning of the market, competitors' actions, understanding consumer needs to shape offerings and business operations (Wei et al., 2011). In the opportunity exploitation capability, firms behave to achieve efficiency by improving the quality of the product/service, lowering cost, and by increasing the reliability of the existing offerings (Lubatkin et al., 2006). It could be a sequential path between opportunity exploration and exploitation capabilities (Benitez et al., 2018). However, firms could inject resources to explore new opportunities but could create economic benefits from existing explored opportunities (Mostafiz et al., 2019a). In this notion, the opportunity exploration and exploitation capabilities are firm-specific and

distinct depending on the experiences and resources at hand (Mainela et al., 2014). Opportunity exploration capability integrates resource configuration and external market demand (Vasilchenko & Morrish, 2011). It can also be derived from unexpected events where strategic capability is needed to facilitate strategic decisions, rational processes and systematic information gathering (Coviello & Munro, 1995). Whereas, opportunity exploitation capability confers the execution of strategies to achieve operational efficiency (Benitez et al., 2018). Vasilchenko and Morrish (2011) suggest that the exploitation of partnership as a great source to recognise opportunities. For instance, General Motor emphasises on alliances to explore (i.e., sense) new opportunities for production process design, and integrating and refining (i.e., opportunity exploitation) the process to improve firm performance. Put simply, opportunity exploration and exploitation capabilities are the heart of the entrepreneurial firm, and it requires oxygen (i.e., knowledge) to transform opportunities into wealth. However, we expect that the wealth creation is subject to the experiences of the firm in harvesting and utilising knowledge effectively and prolifically as inputs to opportunity exploration and exploitation capabilities differ among young and mature export-manufacturing firms.

### **2.2.1. Configuration between young and mature firms**

The exposure to liabilities of newness and foreignness differ among young and mature firms. Due to environmental pressure, young firms are vulnerable to the risk than mature firms as young firms start operating a business with neither skills nor routines (Helfat & Peteraf, 2003). Starting from scratch, these firms lack initial capabilities, knowledge-stocks and resources endowment. Both exploration and exploitation of opportunities get hindered due to the inadequate stock of knowledge and experiences (Katila & Ahuja, 2002). Garnsey (1998) argues that young firms "are hampered by their need to make search processes a prelude to every new problem they encounter" (p. 541). Therefore, the needs for FMK are much more essential for young firms than mature firms. Eventually, young firms build affluent knowledge-stock and develop opportunity exploration and exploitation capabilities. These capabilities will also facilitate strong network relationships, understanding of the market, and open doors for potential collaboration (Mostafiz et al., 2020).

Consequently, mature firms enjoy advantages stemming from existing capabilities and knowledge-stock. Routine learning orientation allows mature firms to nurture capabilities effectively as they build on other resources and capabilities (Levinthal & March, 1993). In the emerging market landscape, the

business environments are chaotic (Mostafiz et al., 2019b) and to respond to uncertainties, mature firms adequately deploy resources to effectively respond to the challenges (Levitt & March, 1988). Eventually, the chances of success are much higher in the mature firms through leveraging knowledge as input to opportunity exploration and exploitation capabilities to develop a new product (Hansen, 1999; Sivadas & Dwyer, 2000), innovation (Tripsas & Gavetti, 2000) and firm performance (Gkypali et al., 2015). However, it has not been the case that mature firms always get advantages from resource, knowledge, and capabilities. Young firms are more proactive, innovative, and risk-taker than mature firms (Harms & Schiele, 2012). For mature firms, *organisational inertia* may hinder the willingness to accumulate new knowledge and capabilities to explore and exploit new opportunities. As Majumdar (1997) mentions, organisational inertia arises from prior experiences that hinder organisational learning. Such inertia may drive mature firms to create economic benefit from existing opportunities rather than exploring new opportunities. Coad et al. (2016) stress that “firm experience may generate obsolescence if the direction of search activities upon which mature firms have embarked is not well suited to the contemporaneous landscape” (p. 388). On the other hand, young firms can take advantages of this organisational inertia faced by mature firms. Taymaz (2005) proffers that young firms “become aware of their actual productivity after observing their performance in the industry” (p. 430). In this process, young firms closely monitor the activities of mature firms and reengineer their strategies. When young firms’ performance is deteriorating than mature firms, then young firms need to catch up and reconfigure resources and capabilities to become competitive in the market (Coad et al., 2016). Thereby, based on the characteristics and behaviours of young and mature firms, we propound the variations in the configurations (i.e., sufficiency) and the necessary conditions (i.e., necessity). The way FMK is accumulated, harvested, and utilised will differ in conjunction with opportunity exploration and exploitation capabilities among the young and mature firms. Hence, we embrace the assumption of equifinality and oppose to the single solution to complement the firm performance.

### 3. Research methodology

#### 3.1. Research context

Bangladesh is an emerging economy<sup>2</sup> with a lot of entrepreneurial potentials. The average annual growth of the economy of Bangladesh has increased by 6.3% over 10 years before 2018 (Ahmed & Brennan, 2019a). Moreover, the apparel industry of Bangladesh has

significantly flourished in recent years, contributing 11.17% of the country’s GDP and 83% of the overall export earnings (Dey, 2019). Prior studies highlight that these entrepreneurs’ visionary behaviour in accumulating FMK (Mostafiz et al., 2019a) has enhanced firm performance by identifying correct international opportunities (Mostafiz et al., 2019c). Even though the country is suffering from a lot of environmental uncertainties (Mostafiz et al., 2019b), the apparel industry has thrived and has achieved striking success (Ahmed & Brennan, 2019b). Previously, firms operating in the apparel industry of Bangladesh were considered contract manufacturers to western brands. However, due to competition and the benefits from the global value chain, these firms have developed the in-house design, and R&D department through product and process innovation (Textile Today, 2016; Topader, 2018) and have become opportunity-driven export-manufacturer firms (Mostafiz et al., 2019b). Given the distinguishing feature of an emerging economy and the apparel industry’s potential, the context provides attractive research setting to investigate the interplay between FMK and opportunity recognition capabilities through the configurational combinations and NCA to provide specific implications to young and mature firms.

#### 3.2. Sample and research design

Sample firms were chosen from the BGMEA ([www.bgmea.com.bd](http://www.bgmea.com.bd)). Approximately 5000 firms are registered with BGMEA (Mostafiz et al., 2019a). Using random sampling methods, we administered the questionnaire (in English) to these firms. In this research context, most of the strategic decisions were taken by the entrepreneurs/founders as they played the CEO’s role in the organisation (Mostafiz et al., 2019a). During the first wave of data collection, the entrepreneurs were responsible for providing data on FMK and opportunity recognition capabilities (i.e., opportunity exploration-exploitation capabilities). The researchers physically visited the firms and collected the data from the entrepreneurs of the firms. In some cases, the entrepreneurs were unable to respond due to their busy schedule; in those cases, the researchers followed the guidelines proposed by Mostafiz et al. (2019b) and approached the next person-in-charge (i.e., Deputy Managing Director) to collect the responses. They were fully responsible for taking the decision in the absence of the entrepreneurs. Moreover, the approach helped us to control social desirability bias by incorporating multiple persons to respond to the questionnaire (Chandler & Hanks, 1994). We approached the finance managers of the firms to assist us by providing data on the performance. After multiple follow-ups, 382 complete responses were received. For data accuracy, an

anonymous person from the firm (e.g., general manager) was approached to verify the correctness of the responses on a five-point Likert scale. Furthermore, we conducted a non-response bias test to identify variances (Armstrong & Overton, 1977). The results of non-response bias test represent non-significant variance among the critical variables of this study. Finally, based on the cut-off point, our study separated young (i.e., 178 firms are ten and less than 10 years old) and mature firms (i.e., 194 firms are more than 10 years old) for further inferential statistical analysis.

#### 4. Measurement

*Outcome variable.* Firm performance was measured using four subjective items as overall profitability, international market share, international reputation, and overall international performance (Mostafiz et al., 2019a). All performance items were measured using a five-point Likert scale as one represents very dissatisfied, and five represents very satisfied. In an emerging economy context, the usability of subjective data is widely accepted as entrepreneurs are reluctant to share objective performance data (Hult et al., 2008). Kirca (2011) also emphasises the usability of subjective data in the emerging economy. Dess and Robinson (1984) propose a strong correlation between subjective and objective measurement and advise using subjective measures when actual data is not available.

*Predictor variables.* FMK as foreign business knowledge (four items), institutional knowledge (three items), and internationalisation knowledge (three items) were sourced from Mostafiz et al. (2019a). Example items are foreign business knowledge (i.e., *knowledge about competitors; about foreign clients; distribution channels; and about effective marketing*), institutional knowledge (i.e., *foreign business laws and regulations; about host government agencies; and about language and norms*), and internationalisation knowledge (i.e., *business experience; ability to deal foreign business contracts; and managing international operations*). Opportunity recognition capabilities were measured by *opportunity exploration capability* (four items) (Cohen & Winn, 2007; Corbett, 2005; Wei et al., 2011), and *opportunity exploitation capability* (four items) (Ko & Butler, 2006; Lubatkin et al., 2006; Pacho, 2018). Example items of opportunity exploration capability are “*continuously explore new markets and new opportunities*”, “*driven by the perception of opportunity while not constrained by the resources at hand*”, “*continuously try to discover additional needs of our customer of which they are unaware*”, and “*search for opportunities in areas where customer have a difficult time expressing the needs*” (Wei et al., 2011, p. 13). Example items of opportunity exploitation capability are “*feasibility and desirability of explored opportunity*” (Ko & Butler, 2006, p. 8);

“*firm’s commitment to improve quality and lower cost from explored opportunities*”, “*firm’s commitment to improve the reliability of its products and service*”, and “*increase firm’s commitment to fine-tuning the offerings to keep customer satisfied*” (Lubatkin et al., 2006, p. 656).

## 5. Analysis

### 5.1. Descriptive statistics

Tables 1a and 2b represent the correlations, mean value, standard deviation, normality, and VIF (variance inflation factors) of young and mature firms. The age of the young firms ranged between 3 and 10 years (mean = 6.64; SD = 1.73); and the age of the mature firms ranged between 11 and 23 years (mean = 17.11; SD = 2.28). The number of employees in young firms ranged between 55 employees and 240 employees, and the number of employees in the mature firms ranged between 165 and 700 employees. The descriptive analysis shows that the constructs are adequately correlated for both young and mature firms. Both datasets are normally distributed, and the effects of multicollinearity among the constructs are minimal (<5) (Graham, 2003).

### 5.2. Common method variance

The key informant survey approach has the potential limitation of the common method bias-variance (CMV). Our study employed both qualitative and quantitative techniques to handle the impact of CMV. *First*, during the data collection period, all psychological separations were removed from the questionnaire to confirm that the respondents were unaware of the research goal (Chang et al., 2010). Moreover, redundant questions were included in the questionnaire to deviate the mind of the respondent. *Second*, two statistical analyses were carried out to identify the impact of CMV in the study. We computed Harman’s one-factor analysis. The results show that the first component percentage of variance is less than 50% (23.46% for young firms; and 21.29% for mature firms), therefore, indicating a minimum effect of CMV (Fuller et al., 2016). Additionally, single latent factor analysis was conducted by using AMOS 24. All items were loaded to a single construct for both young and mature firms. The results of the single-factor analysis are significantly different ( $f_{ij}^2 = 3,408.595$ ,  $df = 901$ ,  $CMIN/df = 3.78$ ,  $RMSEA = 0.123$ ;  $CFI = 0.542$ ) compared to the six confirmatory factor analysis (CFA) ( $f_{ij}^2 = 912.21$ ,  $df = 527$ ,  $CMIN/df = 1.73$ ,  $RMSEA = 0.049$ ,  $CFI = 0.894$ ) for young firms; and for mature firms, results of single-factor analysis are:  $f_{ij}^2 = 3,275.286$ ,  $df = 1012$ ,  $CMIN/df = 3.23$ ,  $RMSEA = 0.112$ ;  $CFI = 0.523$ , which are

significantly poorer than the CFA values  $ffj^2 = 949.572$ ,  $df = 618$ ,  $CMIN/df = 1.5$ ,  $RMSEA = 0.048$ ,  $CFI = 0.902$ . Hence, we conclude that the impact of CMV in this study is minimal (Fuller et al., 2016; Podsakoff et al., 2003).

### 5.3. Reliability and validity

Table 3 represents the results of reliability and validity. The Cronbach’s alpha values are above 0.7 for all constructs representing internal consistency (Hair et al., 2010). The average variance extractor (AVE) values are higher than 0.50 confirming the convergent validity of the constructs and the square-root of AVE values (Tables 1a and 2b) are higher than correspondent correlations confirming the assumptions of discriminant validity (Fornell & Larcker, 1981). Hence, the measurement items used in this study are valid and reliable.

### 5.4. The fsQCA analysis

The conventional statistical methods, such as regression analysis and/or structural equation modelling, are widely acknowledged to analyse symmetrical relationships. These analyses are meant to provide a single solution by adopting a reductionist bivariate statistical approach. On the contrary, fsQCA embraces equifinality and provides the statistical solution for asymmetrical relationships (Ragin,

2009). In the asymmetrical relationship, the predictor variables fail to complement the outcome variables; thus, creating contradictions with theoretical assumptions (Woodside, 2014). All cases are divided into highest–lowest quintile using the mean value to perform cross-tabulation analysis to identify contrarian cases (Hughes et al., 2017). Tables 4a and 5b represent the results of contrarian case analyses for young firms and mature firms, respectively. Results highlight (grey zones) significant presence of contrarian cases both for young and mature firms. For instance, 8.4%  $((2 + 5 + 7 + 1)/178)$  of cases represent a low-level of foreign institutional knowledge with a high-level of performance in young firms. Similarly, in mature firms, 13.4%  $((20 + 5 + 1)/194)$  of cases are contradicting as high level of opportunity exploration capability with low level of firm performance. We also computed the effect size between each condition and the performance of young and mature firms. Thus, the presence of contrarian cases among all relationships and considerably small effect size values warrant the fsQCA application of these asymmetrical relationships (Hughes et al., 2017; Woodside, 2014).

Following the guidelines by Ragin (2009), we calibrate the original data to fuzzy membership score ranging from 0.00 to 1.00, where the non-membership score represents 5%, cross-over anchors are 50%, and the full-membership score represents 95% of the value. These fuzzy scores are used to construct the truth table algorithm for

**Table 1.** Correlation matrix and descriptive statistics of young firms (N= 178).

Constructs in the model	1	2	3	4	5	6
(1) Foreign business knowledge	<b>0.749</b>					
(2) Foreign institutional knowledge	0.400**	<b>0.714</b>				
(3) Internationalisation knowledge	0.490**	0.437**	<b>0.724</b>			
(4) Opportunity exploration capability	0.489**	0.490**	0.476**	<b>0.706</b>		
(5) Opportunity exploitation capability	0.435**	0.418**	0.434**	0.441**	<b>0.713</b>	
(6) Firm performance	0.185*	0.155*	0.198**	0.406**	0.371**	<b>0.730</b>
Mean score	17.46	13.56	13.39	17.11	17.58	18.54
Standard deviation	2.17	2.56	1.02	1.89	2.68	1.84
Skewness: Statistics	-0.068	0.011	-0.500	0.042	0.129	0.225
Kurtosis: Statistics	0.381	0.251	0.165	0.250	0.599	-0.392
VIF	1.52	1.454	1.540	2.523	1.156	1.223

Note: Diagonal is the square root of the AVE.

\*Correlations significant at the 0.05 level.

\*\*Correlations significant at the 0.01 level.

**Table 2.** Correlation matrix and descriptive statistics of mature firms (N= 194).

Constructs in the model	1	2	3	4	5	6
(1) Foreign business knowledge	<b>0.736</b>					
(2) Foreign institutional knowledge	0.308**	<b>0.772</b>				
(3) Internationalisation knowledge	0.301**	0.386**	<b>0.708</b>			
(4) Opportunity exploration capability	0.485**	0.431**	0.450**	<b>0.742</b>		
(5) Opportunity exploitation capability	0.470**	0.478**	0.377**	0.454**	<b>0.721</b>	
(6) Firm performance	0.163*	0.229**	0.313**	0.422**	0.387**	<b>0.782</b>
Mean score	17.34	13.67	13.44	17.42	17.69	18.49
Standard deviation	2.29	2.58	1.41	1.19	1.43	2.21
Skewness: Statistics	0.024	0.012	0.207	-0.170	-0.216	-0.125
Kurtosis: Statistics	0.326	-0.131	-0.196	-0.486	-0.294	-1.068
VIF	1.363	1.396	1.368	2.248	1.020	1.416

Note: Diagonal is the square root of the AVE.

\*Correlations significant at the 0.05 level.

\*\*Correlations significant at the 0.01 level.

**Table 3.** Summary of the reliability and validity analysis.

Constructs	Std. loadings (Young firms, n= 178)	Std. loadings (Mature firms, n= 194)
Foreign business knowledge	( $\alpha = 0.746$ , AVE = 0.523)	( $\alpha = 0.749$ , AVE = 0.572)
Foreign institutional knowledge	( $\alpha = 0.728$ , AVE = 0.534)	( $\alpha = 0.756$ , AVE = 0.531)
Internationalisation knowledge	( $\alpha = 0.732$ , AVE = 0.563)	( $\alpha = 0.742$ , AVE = 0.527)
Opportunity exploration capability	( $\alpha = 0.728$ , AVE = 0.536)	( $\alpha = 0.721$ , AVE = 0.540)
Opportunity exploitation capability	( $\alpha = 0.756$ , AVE = 0.527)	( $\alpha = 0.763$ , AVE = 0.511)
Firm performance	( $\alpha = 0.730$ , AVE = 0.586)	( $\alpha = 0.743$ , AVE = 0.584)

**Table 4.** Contrarian case analysis for young firms (N= 178).

Construct/Quintile	Firm performance					Total count	Effect size
	1	2	3	4	5		
Foreign business knowledge	1	0	4	0	1	0	5
	2	5	9	3	0	3	20
	3	2	14	25	30	4	75
	4	0	6	4	26	3	39
Total count	5	0	0	3	16	20	39
	7	33	35	73	30	178	
Foreign institutional knowledge	1	1	0	2	0	0	3
	2	6	11	5	7	1	30
	3	0	20	23	31	9	83
	4	0	1	4	12	0	17
Total count	5	0	1	1	23	20	45
	7	33	35	73	30	178	
Internationalisation knowledge	1	0	2	1	2	2	7
	2	5	6	3	4	1	19
	3	2	17	14	21	8	62
	4	0	7	15	39	10	71
Total count	5	0	1	2	7	9	19
	7	33	35	73	30	178	
Opportunity exploration capability	1	0	2	1	0	0	3
	2	5	5	3	1	1	15
	3	2	22	25	16	7	72
	4	0	4	6	43	2	55
Total count	5	0	0	0	13	20	33
	7	33	35	73	30	178	
Opportunity exploitation capability	1	0	2	0	1	1	4
	2	2	4	5	6	5	22
	3	4	18	7	26	7	62
	4	1	9	22	38	15	85
Total count	5	0	0	1	2	2	5
	7	33	35	73	30	178	

both young and mature firms. The truth table algorithm is used to identify sufficient configurations by following the minimum consistency cut-off point of 0.75 (Cheng et al., 2013; Misangyi & Acharya, 2014) and dropping the rest of the cases (Fiss, 2011). We then computed standard analysis to identify configurational combinations with high scores to the firm performance. Although specific analysis also can produce fsQCA outputs, the standard analysis is widely acknowledged in management research (Hughes et al., 2017). Table 6 represents the output of intermediate solutions<sup>3</sup> highlighting combinations of configurations to achieve firm performance. Two parameters of fit indices as consistency and coverage are used to

**Table 5.** Contrarian case analysis for mature firms (N= 194).

Construct/Quintile	Firm performance					Total count	Effect size
	1	2	3	4	5		
Foreign business knowledge	1	0	0	1	1	0	2
	2	1	11	8	4	4	28
	3	7	31	32	26	7	103
	4	0	12	12	14	7	45
Total count	5	0	2	4	6	5	17
	8	56	57	51	23	195	
Foreign institutional knowledge	1	2	6	2	1	2	13
	2	4	19	1	3	3	30
	3	1	24	31	28	12	96
	4	1	6	5	6	5	23
Total count	5	0	1	18	13	1	33
	8	56	57	51	23	195	
Internationalisation knowledge	1	0	0	0	0	0	0
	2	1	5	3	0	1	10
	3	2	23	23	17	3	68
	4	4	26	23	21	8	82
Total count	5	1	2	8	13	11	35
	8	56	57	51	23	195	
Opportunity exploration capability	1	0	1	0	0	0	1
	2	0	1	2	2	0	5
	3	7	29	20	6	2	64
	4	1	20	29	24	5	79
Total count	5	0	5	6	19	16	46
	8	56	57	51	23	195	
Opportunity exploitation capability	1	0	1	0	0	0	1
	2	0	0	1	2	0	3
	3	5	36	4	2	1	48
	4	3	13	46	29	8	99
Total count	5	0	6	6	18	14	44
	8	56	57	51	23	195	

explain the fsQCA results (Ragin, 2009). Hughes et al. (2017) mention that the “consistency measures the degree to which a relation of necessity or sufficiency between a causal condition and an outcome is met within a given dataset; coverage provides a measure of empirical relevance” (analogous to  $R^2$  in regression) (p. 180). *First*, the presence of high consistency exhibits the adequacy of the sufficiency in the subset relationships (Cheng et al., 2013; Fiss, 2011; Misangyi & Acharya, 2014). The minimum consistency value for young firms is 0.85, and for mature firms 0.81, represent very high-level of consistency. Thereby, we propound that these configurations are sufficient conditions for the performance for young and mature firms.

*Second*, coverage represents the extent to which the configurations are responsible for achieving the outcomes (Fiss, 2011). The minimum threshold values of 0.30 for raw and solution coverage (Hughes et al., 2017) indicate that the young and mature firms have achieved an adequate extent of the performance. Two configurational combinations are identified for young firms, and three configurational combinations are identified for mature firms. Figure 1 and Figure 2 exhibit the graphical representation of the causal configurations. In summary, multiple combinations of the configurations co-exist (Fiss, 2011) and firms are not bound to



**Table 6.** fsQCA analysis of the configurational combinations between young and mature firms.

	Path	FBK	FIK	IK	OExC	OEC	Raw coverage	Unique coverage	Consistency	Solution coverage	Solution consistency
Young firms (n= 178)	1a	●	●		●		0.418495	0.043696	0.941428	0.825031	0.764683
	2a	●	○	○	○	○	0.327974	0.027881	0.851836		
Mature firms (n= 194)	1b	○	●	●	○	●	0.415412	0.0691722	0.970661	0.849855	0.72854
	2b	○	○	○	○	○	0.305142	0.0076386	0.817973		
	3b	●	○	○	●	●	0.365175	0.0088377	0.899738		

FBK, foreign business knowledge; FIK, foreign institutional knowledge; IK, internationalisation knowledge; OExC, opportunity exploration capability; OEC, opportunity exploitation capability.  
 “●” represent full membership; “○” represent partial membership, and “blank” represent null membership

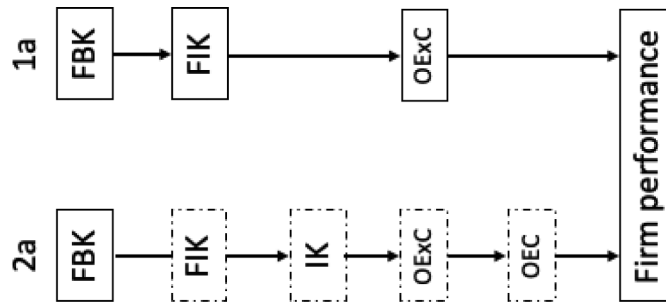

**Figure 1.** Configurational paths for young firms. □ represents partial membership and ▣ represents full membership. FBK, foreign business knowledge; FIK, foreign institutional knowledge; IK, internationalisation knowledge; OExC, opportunity exploration capability; OEC, opportunity exploitation capability.

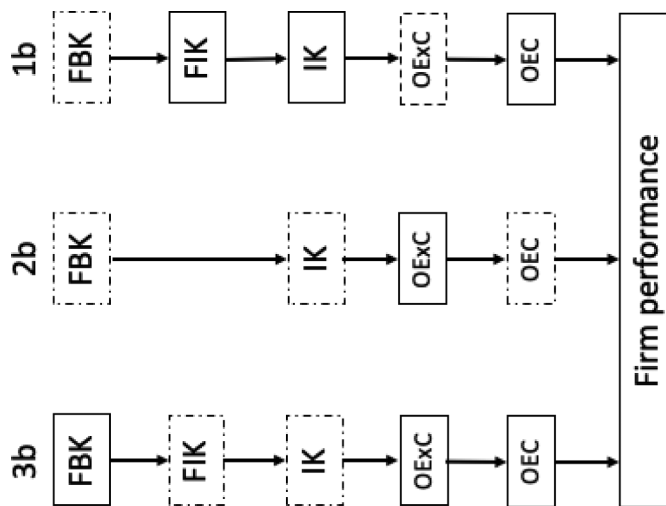

**Figure 2.** Configurational paths for mature firms. □ represents partial membership and ▣ represents full membership. FBK, foreign business knowledge; FIK, foreign institutional knowledge; IK, internationalisation knowledge; OExC, opportunity exploration capability; OEC, opportunity exploitation capability.

follow a single model, rather could transmit to another model based on the strategic priorities and consequences.

**5.5. Necessary condition analysis (NCA)**

The NCA is a process of identifying *necessary condition* by “formulating a quantitative in *degree* and expressing which level of condition X (predictor) is necessary for which level of condition Y (outcome)” (Dul, 2016b). The benefits of employing NCA as it draws the ceiling line on top of all cases, and does not require the ceiling line to be diagonal (Dul, 2015). Besides, NCA can be done

with both calibrated fuzzy score as well as with the original score (Dul, 2016a). We used the calibrated membership scores of fsQCA to perform NCA. Table 7 highlights the results of NCA analysis. The recommended NCA consistency cut-off point of (i.e., >0.90) is used to determine the threshold (Taheri et al., 2019). The results suggest that the necessary conditions for opportunity exploration capability and opportunity exploitation capability in young firms differ from mature firms. For the firm performance, foreign business knowledge and opportunity exploration capability are the necessary conditions for young firms, whereas foreign institutional knowledge (i.e., quasi-significant – very close

**Table 7.** NCA results for achieving performance in both young and mature firms.

Outcome condition: opportunity exploration capability				
	Young firms		Mature firms	
Condition	Consistency	Coverage	Consistency	Coverage
FBK	<b>0.967</b>	0.749	0.824	0.638
FIK	0.817	0.721	<b>0.897</b>	0.792
IK	0.843	0.648	0.769	0.564
Outcome condition: opportunity exploitation capability				
	Young firms		Mature firms	
Condition	Consistency	Coverage	Consistency	Coverage
FBK	<b>0.893</b>	0.737	0.733	0.518
FIK	0.678	0.672	0.839	0.681
IK	0.657	0.437	<b>0.955</b>	0.699
Outcome variable: firm performance				
	Young firms		Mature firms	
Condition	Consistency	Coverage	Consistency	Coverage
FBK	<b>0.906</b>	0.712	0.771	0.694
FIK	0.824	0.624	<b>0.896</b>	0.513
IK	0.855	0.693	<b>0.967</b>	0.722
OExC	<b>0.901</b>	0.744	0.842	0.619
OEC	0.867	0.619	<b>0.898</b>	0.659

FBK: foreign business knowledge, FIK: foreign institutional knowledge, IK: internationalisation knowledge, OExC: opportunity exploration capability, OEC: opportunity exploitation capability.

Note: The level of consistency is significant at the cut-off point of >0.900.

to the cut-off point), internationalisation knowledge and opportunity exploitation capability (i.e., quasi-significant) are the necessary conditions for mature firms.

## 6. Contribution and discussion

The fundamental objective of this study was to investigate the configurations between FMK and opportunity recognition capabilities to complement the firm performance. Two questions were addressed in this study: (a) *how do FMK and opportunity recognition capabilities configure to form pathways to performance success?* (b) *Do all types of firms (young vs mature) benefit from the common configurational path?* To answer, we challenge the reductionist bivariate analyses and embrace the assumption of equifinality by probing that there is no single solution, but multiple routes exist to complement the firm performance. Hence, our study builds significant theoretical and methodological contributions. Our contribution echoes the long-standing call by Venkataraman (1997, p. 122) “where do the opportunities to create goods and services in the future come from?” We argue that recognising opportunities requires opportunity exploration and exploitation capabilities that are sourced from the breadth of foreign business, institution, and internationalisation knowledge. It is noteworthy to mention that the configurations to achieve performance success are subject to their age. Young firms must tap into foreign business knowledge through leveraging opportunity exploration capability. In contrast, mature firms get significant performance success from opportunity exploitation capability by accumulating, harvesting, and utilising foreign

institutional and internationalisation knowledge. Thereby, our study advances the theoretical knowledge on FMK (Eriksson & Chetty, 2003; Eriksson et al., 1997; Mostafiz et al., 2019a; Musteen et al., 2014), and opportunity recognition capabilities (Bhagavatula et al., 2010; Kraus et al., 2017; Lumpkin & Lichtenstein, 2005; Mostafiz et al., 2019b) by offering multiple combinations of the configurations among export-manufacturing firms. Methodologically, this study is one of which that introduces NCA (Dul, 2016a, 2016b) along with fsQCA in knowledge management literature and provides empirical evidence to its relevance.

### 6.1. Assessment of fsQCA results

We identified two paths for young firms (i.e., paths 1a and 2a) and three paths for mature firms (i.e., paths 1b, 2b, and 3b). Our results suggest that young firms get benefited from significant assortments of foreign business knowledge. Both paths represent full membership of foreign business knowledge; where path 1a also emphasises full membership of foreign institutional knowledge and null membership of internationalisation knowledge to complement the firm performance. Path 1a shows that the inputs of opportunity exploration capability are derived from foreign business and institutional knowledge. Whereas, path 1b indicates that young firms can achieve performance success by having internationalisation knowledge (i.e., partial membership) and leveraging on opportunity exploitation capability. From our results, we propound that opportunistic exploration and exploitation capabilities are not sequential. Prior study suggests that opportunity exploration and exploitation capability require simultaneous and balanced utilisation of both capabilities (Durcikova et al., 2011). Our findings of the combinations of configurations preclude us from proposing the sequential approach of opportunity exploration and exploitation capabilities to complement performance (Benitez et al., 2018) for young export-manufacturing apparel firms. The raw coverage value for path 1a is much stronger than path 2a, implying that exploring the new market to expand the business and identifying unique opportunities related to sourcing new consumer, suppliers, partner and alliances will provide significant performance success to young firms (Mostafiz et al., 2019b). Prior study shows that young firms are more innovative than mature firms (Coad et al., 2016) as they have high propensity to innovate their products. These apparel export-manufacturing firms in Bangladesh have their in-house product innovation (Textile Today, 2016) and process innovation units (Mostafa & Klepper, 2018). These apparel firms must explore and exploit opportunities to facilitate cutting edge process and product innovation to become competitive and thrive

in the international market. Additionally, understanding customer needs and predicting market changes in advance also assist these young firms to enhance performance. At the initial stage, accumulating foreign business and institutional knowledge is beneficial, and entrepreneurs must amplify opportunity exploration capability to sense and seize new opportunities from knowledge (Mostafiz et al., 2019a).

We propound three configurational combinations (i.e., paths 1b, 2b, and 3b) for mature firms. Contrary to young firms, we have identified a significant presence of internationalisation knowledge among mature firms. Our study captures internationalisation knowledge based on the firm's ability to do international business. Hence, the result is legitimate to represent the high presence of internationalisation knowledge that includes affluent business experience, ability to deal with foreign business contracts, and international operations. Mature firms often suffer from organisational inertia, which is driven by corporate experiences. Our study echoes Coad et al. (2016) propositions as mature firms focus more on opportunity exploitation than opportunity exploration. Our study suggests that mature firms operating in the apparel industry of Bangladesh get enormous performance success from improvising existing offerings (e.g., exploitation). Although, path 3b suggests that these mature export-manufacturing firms are also keen to accumulate new foreign business and institutional knowledge to leverage both opportunity exploration and exploitation capabilities to sustain in the international market (Musteen et al., 2014). Comparatively, path 2b has the lowest raw coverage and consistency values than path 1b and 3b. Interestingly, this particular path indicates that mature firms also could get performance success by accumulating foreign business (i.e., partial membership) and internationalisation knowledge (i.e., full membership) as the resources (i.e., knowledge) to both opportunity exploration and exploitation capabilities and bring innovation within the organisation. Higher level of capital investment to promote R&D and innovation may not be a problem for mature firms (Gkypali et al., 2015) compared to young firms. However, young firms can achieve a higher growth rate by investing in innovation (Coad et al., 2016). Due to organisational agility and ambidexterity, the chances of survival amongst mature firms (March, 1991) are higher than young firms. Because practising innovation through exploration and exploitation of opportunities is risky as it may result in faster growth or cause rapid decline. In a nutshell, entering a new market and understanding consumer needs as opportunities are not sufficient, but improving the quality of the offering, lowering the cost, improving the

reliability of the existing products and increasing firms commitment are considered highly pivotal strategies to tap into the international market (Mostafiz et al., 2019a) for both young and mature firms.

## 6.2. Assessment of NCA results

To get more in-depth insights and compensate for the limitation of fsQCA (i.e., *sufficiency*), we identify the necessary condition for opportunity exploration and exploitation capabilities and firm performance. Our results show that opportunity exploration capability significantly benefits from foreign business knowledge in young firms (i.e., 0.967), whereas foreign institutional knowledge is the necessary condition to complement opportunity exploration capability (i.e., 0.897 – quasi-significant as close to the cut-off value of 0.90 (Dul, 2016b)) in the mature firms. Our findings also suggest that foreign business knowledge is critically beneficial to opportunity exploitation capability (i.e., 0.893 – quasi-significant) among these young export-manufacturing apparel firms. However, internationalisation knowledge is the necessary condition to complement opportunity exploitation capability (i.e., 0.955) among mature export-manufacturing apparel firms. Finally, as the necessary conditions to achieve firm performance, we have identified that foreign business knowledge (i.e., 0.906) and opportunity exploration capability (i.e., 0.901) have turned out to be significant in young firms; foreign institutional knowledge (i.e., 0.896-quasi-significant), internationalisation knowledge (i.e., 0.967), and opportunity exploitation capability (0.898-quasi-significant) are the significant necessary conditions to enhance performance success among the mature firms. Knowledge requires adequate transformation, analysis and conversion to realise potential opportunities (Jayasingam et al., 2013). Thereby, both young and mature firms in the apparel industry of Bangladesh must nurture their opportunity exploration and exploitation capabilities to become innovative. Aforementioned, innovation is the key to success in this competitive industry (Textile Today, 2016). Opulent knowledge will facilitate top-notch product and process innovations through new opportunities. As Peiris et al. (2015) mention, opportunities create the bridge between knowledge utilisation and innovation. Thus, vast knowledge is the ultimate source of a firm's survival. Thereby, our study contributes to the FMK literature (Mostafiz et al., 2019a; Musteen et al., 2014) by propounding that regardless of firm type, FMK as a foreign business, institutional and internationalisation knowledge are essential sources to opportunity recognition capabilities (George et al., 2016) as opportunity exploration and exploitation capabilities (Benitez et al., 2018;

Durcikova et al., 2011; Zahra et al., 2005) to achieve performance success.

## 7. Limitation and conclusion

The primary objective of this research was to establish the configurational combinations between FMK and opportunity recognition capabilities to achieve firm performance. We used fsQCA to establish these configurational combinations and employed NCA to determine necessary conditions. We identified that knowledge plays a significant but varying role among young and mature firms. It minimises the potential risks of entrepreneurs from committing to wrong opportunities. An essential finding of this research is that knowledge contributes differently to the opportunity exploration and exploitation capabilities depending on the firm's age. The way the young firms explore, and exploit opportunities varies from mature firms. Opportunities are rare and vulnerable. Therefore, adequate orientations are required to effectively utilise the knowledge (Mostafiz et al., 2021) and nurture opportunity recognition capabilities.

There are a few limitations of the study that cannot be ignored. Our study acknowledges that one of the limitations of fsQCA is the generalisability issue. Our results may or may not manifest consistency if replicated. Therefore, to achieve higher consensus, a similar study should be carried out in other economies with different industries, for instance, service organisations or high-tech industry could bring new insights. Second, our results are influenced by subjective behavioural data; hence, incorporation of objective performance data can capture more salient properties of the organisation. Regarding opportunities, longitudinal studies are required to understand the long-term benefit of recognised opportunities and the firm's commitments. As opportunities are vulnerable, therefore, in the short term, it might be beneficial, but in the long-run firms might discontinue operations and let the opportunity go by. For example, many US firms are suspending their outsourced manufacturing operations in the emerging part of the world and relocating the plant inside the USA by believing that the decomposition of opportunity will bring in more value to the firms. Future research could investigate this perspective and investigate new sources of knowledge and how firms can explore and exploit more beneficial opportunities from these sources. International market amid uncertainties and rigorous forward-looking entrepreneurial actions are essential to recognise new opportunities.

## Notes

1. Coad et al. (2016) propose that the young firms are ranged from 0 to 10 years old and firms more than 10

years old are considered mature firms. In contrast, Gkypali et al. (2015) propose a higher threshold to conceptualise young (less than 15 years) and mature firms (more than 15 years). The export-manufacturing apparel industry of Bangladesh has established in 1975 (Textile Today, 2016). We adopted the suggestion by Coad et al. (2016) in operationalising young and mature firms in this study.

2. According to UNCTAD (2015), Bangladesh is listed as least-developed nations with low gross income per capital, weak human development index and high-level of economic vulnerability.
3. Three different outputs as complex solutions, parsimonious solutions, and intermediate solutions are produced by the standard analysis. Based on the values in the truth table algorithm as logical remainders and zero cases, the result of each solution differs. The most acknowledged solution in management research is the intermediate solution, as it has the superiority to the parsimonious and complex solutions (Cheng et al., 2013; Hervás-Oliver et al., 2015).

## Disclosure statement

No potential conflict of interest was reported by the author(s).

## ORCID

Md Imtiaz Mostafiz  <http://orcid.org/0000-0002-4362-4521>

Murali Sambasivan  <http://orcid.org/0000-0002-5779-4126>

## References

- Ahmed, F. U., & Brennan, L. (2019a). The impact of Founder's human capital on firms' extent of early internationalization: Evidence from a least-developed country. *Asia Pacific Journal of Management*, 36(3), 615–659. <https://doi.org/10.1007/s10490-019-09646-4>
- Ahmed, F. U., & Brennan, L. (2019b). An institution-based view of firms' early internationalization. *International Marketing Review*, 36(6), 911–954. <https://doi.org/10.1108/IMR-03-2018-0108>
- Anders Paarup, N. (2006). Understanding dynamic capabilities through knowledge management. *Journal of Knowledge Management*, 10(4), 59–71. <https://doi.org/10.1108/13673270610679363>
- Armstrong, J. S., & Overton, T. S. (1977). Estimating non-response bias in mail surveys. *Journal of Marketing Research*, 14(3), 396–402. <https://doi.org/10.1177/002224377701400320>
- Bandera, C., Bartolacci, M. R., & Passerini, K. (2016). Knowledge management and entrepreneurship: A contradictory recipe. *International Journal of Knowledge Management*, 12(3), 1–14. <https://doi.org/10.4018/IJKM.2016070101>
- Baron, R. A. (2006). Opportunity recognition as pattern recognition: How entrepreneurs “connect the dots” to identify new business opportunities. *Academy of Management Perspectives*, 20(1), 104–119. <https://doi.org/10.5465/amp.2006.19873412>
- Barringer, B. R., & Ireland, R. D. (2008). *Entrepreneurship* (2 ed.). New Jersey: Pearson Education.

- Benitez, J., Llorens, J., & Braojos, J. (2018). How information technology influences opportunity exploration and exploitation firm's capabilities. *Information & Management*, 55(4), 508–523. <https://doi.org/10.1016/j.im.2018.03.001>
- Bhagavatula, S., Elfring, T., Van Tilburg, A., & Van De Bunt, G. G. (2010). How social and human capital influence opportunity recognition and resource mobilization in India's handloom industry. *Journal of Business Venturing*, 25(3), 245–260. <https://doi.org/10.1016/j.jbusvent.2008.10.006>
- Cantwell, J., & Mudambi, R. (2005). MNE competence-creating subsidiary mandates. *Strategic Management Journal*, 26(12), 1109–1128. <https://doi.org/10.1002/smj.497>
- Chandler, G. N., & Hanks, S. H. (1994). Market attractiveness, resource-based capabilities, venture strategies, and venture performance. *Journal of Business Venturing*, 9(4), 331–349. [https://doi.org/10.1016/0883-9026\(94\)90011-6](https://doi.org/10.1016/0883-9026(94)90011-6)
- Chang, S. J., Van Witteloostuijn, A., & Eden, L. (2010). From the editors: Common method variance in international business research. *Journal of International Business Studies*, 41(2), 178–184. <https://doi.org/10.1057/jibs.2009.88>
- Cheng, C.-F., Chang, M.-L., & Li, C.-S. (2013). Configural paths to successful product innovation. *Journal of Business Research*, 66(12), 2561–2573. <https://doi.org/10.1016/j.jbusres.2012.10.006>
- Coad, A., Segarra, A., & Teruel, M. (2016). Innovation and firm growth: Does firm age play a role? *Research Policy*, 45(2), 387–400. <https://doi.org/10.1016/j.respol.2015.10.015>
- Cohen, B., & Winn, M. I. (2007). Market imperfections, opportunity and sustainable entrepreneurship. *Journal of Business Venturing*, 22(1), 29–49. <https://doi.org/10.1016/j.jbusvent.2004.12.001>
- Corbett, A. C. (2005). Experiential learning within the process of opportunity identification and exploitation. *Entrepreneurship Theory and Practice*, 29(4), 473–491. <https://doi.org/10.1111/j.1540-6520.2005.00094.x>
- Coviello, N., & Munro, H. (1995). Growing the entrepreneurial firm; networking for international market development. *European Journal of Marketing*, 29(7), 49–61. <https://doi.org/10.1108/03090569510095008>
- Dess, G. G., & Robinson, R. B., Jr. (1984). Measuring organizational performance in the absence of objective measures: The case of the privately-held firm and conglomerate business unit. *Strategic Management Journal*, 5(3), 265–273. <https://doi.org/10.1002/smj.4250050306>
- Dey, P. (2019). *RMG sector's contribution to GDP down by 3%*. *Trade & Business*. Textile Today. Retrieved from <https://www.textiletoday.com.bd/rmg-sectors-contribution-gdp-downs-3-2/>
- Drazin, R., & Van De Ven, A. H. (1985). Alternative forms of fit in contingency theory. *Administrative Science Quarterly*, 30(4), 514–539. <https://doi.org/10.2307/2392695>
- Dul, J. (2015). *Necessary Condition Analysis (NCA) for R: A quick start guide*. <http://ssrn.com/abstract=2624981> or <http://repub.eur.nl/pub/78323/>
- Dul, J. (2016a). Identifying single necessary conditions with NCA and fsQCA. *Journal of Business Research*, 69(4), 1516–1523. <https://doi.org/10.1016/j.jbusres.2015.10.134>
- Dul, J. (2016b). Necessary condition analysis (NCA) logic and methodology of “necessary but not sufficient” causality. *Organizational Research Methods*, 19(1), 10–52. <https://doi.org/10.1177/1094428115584005>
- Durcikova, A., Fadel, K. J., Butler, B. S., & Galletta, D. F. (2011). Research note—knowledge exploration and exploitation: The impacts of psychological climate and knowledge management system access. *Information Systems Research*, 22(4), 855–866. <https://doi.org/10.1287/isre.1100.0286>
- Eckhardt, J. T., & Shane, S. A. (2003). Opportunities and entrepreneurship. *Journal of Management*, 29(3), 333–349. <https://doi.org/10.1177/014920630302900304>
- Eriksson, K., & Chetty, S. (2003). The effect of experience and absorptive capacity on foreign market knowledge. *International Business Review*, 12(6), 673–695. <https://doi.org/10.1016/j.ibusrev.2003.07.001>
- Eriksson, K., Johanson, J., Majkgård, A., & Sharma, D. D. (1997). Experiential knowledge and costs in the internationalization process. *Journal of International Business Studies*, 28(2), 337–360. <https://doi.org/10.1057/palgrave.jibs.8490104>
- Fiss, P. C. (2011). Building better causal theories: A fuzzy set approach to typologies in organization research. *Academy of Management Journal*, 54(2), 393–420. <https://doi.org/10.5465/amj.2011.60263120>
- Fornell, C., & Larcker, D. F. (1981). Evaluating structural equation models with unobservable variables and measurement error. *Journal of Marketing Research*, 18(1), 39–50. <https://doi.org/10.1177/002224378101800104>
- Fuller, C. M., Simmering, M. J., Atinc, G., Atinc, Y., & Babin, B. J. (2016). Common methods variance detection in business research. *Journal of Business Research*, 69(8), 3192–3198. <https://doi.org/10.1016/j.jbusres.2015.12.008>
- Garnsey, E. (1998). A theory of the early growth of the firm. *Industrial and Corporate Change*, 7(3), 523–556. <https://doi.org/10.1093/icc/7.3.523>
- George, N. M., Parida, V., Lahti, T., & Wincent, J. (2016). A systematic literature review of entrepreneurial opportunity recognition: Insights on influencing factors. *International Entrepreneurship and Management Journal*, 12(2), 309–350. <https://doi.org/10.1007/s11365-014-0347-y>
- Gil, A. J., & Carrillo, F. J. (2016). Knowledge transfer and the learning process in Spanish wineries. *Knowledge Management Research & Practice*, 14(1), 60–68. <https://doi.org/10.1057/kmrp.2014.12>
- Gkypali, A., Rafailidis, A., & Tsekouras, K. (2015). Innovation and export performance: Do young and mature innovative firms differ. *Eurasian Business Review*, 5(2), 397–415. <https://doi.org/10.1007/s40821-015-0030-4>
- Graham, M. H. (2003). Confronting multicollinearity in ecological multiple regression. *Ecology*, 84(11), 2809–2815. <https://doi.org/10.1890/02-3114>
- Grant, R. (1996). Toward a knowledge-based theory of the firm. *Strategic Management Journal*, 17(1), 109–122. <https://doi.org/10.1002/smj.4250171110>
- Hair, J. F., Anderson, R. E., Babin, B. J., & Black, W. C. (2010). *Multivariate data analysis: A global perspective* (Vol. 7). Pearson.
- Hansen, M. T. (1999). The search-transfer problem: The role of weak ties in sharing knowledge across organization subunits. *Administrative Science Quarterly*, 44(1), 82–111. <https://doi.org/10.2307/2667032>
- Harms, R., & Schiele, H. (2012). Antecedents and consequences of effectuation and causation in the international new venture creation process. *Journal of International Entrepreneurship*, 10(2), 95–116. <https://doi.org/10.1007/s10843-012-0089-2>

- Helfat, C. E., & Peteraf, M. A. (2003). The dynamic resource-based view: Capability life cycles. *Strategic Management Journal*, 24(10), 997–1010. <https://doi.org/10.1002/smj.332>
- Hervas-Oliver, J. L., Sempere-Ripoll, F., & Arribas, I. (2015). Asymmetric modeling of organizational innovation. *Journal of Business Research*, 68(12), 2654–2662. <https://doi.org/10.1016/j.jbusres.2015.04.005>
- Huber, G. P. (1991). Organizational learning: The contributing processes and the literatures. *Organization Science*, 2(1), 88–115. <https://doi.org/10.1287/orsc.2.1.88>
- Hughes, M., Cesinger, B., Cheng, C. F., Schuessler, F., & Kraus, S. (2017). A configurational analysis of network and knowledge variables explaining Born Globals' and late internationalizing SMEs' international performance. *Industrial Marketing Management*, 80(5), 172–187. <https://doi.org/10.1016/j.indmarman.2017.12.001>
- Hult, G. T. M., Ketchen, D. J., Jr, Griffith, D. A., Chabowski, B. R., Hamman, M. K., Dykes, B. J., Cavusgil, S. T., & Cavusgil, S. T. (2008). An assessment of the measurement of performance in international business research. *Journal of International Business Studies*, 39(6), 1064–1080. <https://doi.org/10.1057/palgrave.jibs.8400398>
- Jayasingam, S., Ansari, M. A., Ramayah, T., & Jantan, M. (2013). Knowledge management practices and performance: Are they truly linked? *Knowledge Management Research & Practice*, 11(3), 255–264. <https://doi.org/10.1057/kmrp.2012.5>
- Katila, R., & Ahuja, G. (2002). Something old something new: A longitudinal study of search behavior and new product introduction. *Academy of Management Journal*, 45(6), 1183–1194. <https://doi.org/10.5465/3069433>
- Kearney, C., Soleimanof, S., & Wales, W. J. (2018). Examining facilitative configurations of entrepreneurially oriented growth: An information processing perspective. *British Journal of Management*, 29(3), 514–533. <https://doi.org/10.1111/1467-8551.12217>
- Khilstrom, R., & Laffont, J. (1979). A general equilibrium entrepreneurial theory of firm formation based on risk aversion. *Journal of Political Economy*, 87(4), 719–748. <https://doi.org/10.1086/260790>
- Kirca, A. H. (2011). The effects of market orientation on subsidiary performance: Empirical evidence from MNCs in Turkey. *Journal of World Business*, 46(4), 447–454. <https://doi.org/10.1016/j.jwb.2010.10.005>
- Kirzner, I. M. (1997). Entrepreneurial discovery and the competitive market process: An Austrian approach. *The Journal of Economic Literature*, 35(1), 60–85. <https://www.jstor.org/stable/2729693>
- Knight, G. A., & Liesch, P. W. (2016). Internationalization: From incremental to born global. *Journal of World Business*, 51(1), 93–102. <https://doi.org/10.1016/j.jwb.2015.08.011>
- Ko, S., & Butler, J. E. (2006). Prior knowledge, bisociative mode of thinking and entrepreneurial opportunity identification. *International Journal of Entrepreneurship and Small Business*, 3(1), 3–16. <https://doi.org/10.1504/IJESB.2006.008659>
- Kontinen, T., & Ojala, A. (2011). Network ties in the international opportunity recognition of family SMEs. *International Business Review*, 20(4), 440–453. <https://doi.org/10.1016/j.ibusrev.2010.08.002>
- Kraus, S., Niemand, T., Angelsberger, M., Mas-Tur, A., & Roig-Tierno, N. (2017). Antecedents of international opportunity recognition in born global firms. *Journal of Promotion Management*, 23(3), 1–21. <https://doi.org/10.1080/10496491.2017.1294869>
- Levinthal, D. A., & March, J. G. (1993). The myopia of learning. *Strategic Management Journal*, 14(8), 95–112. <https://doi.org/10.1002/smj.4250141009>
- Levitt, B., & March, J. G. (1988). Organizational learning. *Annual Review of Sociology*, 14(1), 319–338. <https://doi.org/10.1146/annurev.so.14.080188.001535>
- Lubatkin, M. H., Simsek, Z., Ling, Y., & Veiga, J. F. (2006). Ambidexterity and performance in small-to medium-sized firms: The pivotal role of top management team behavioral integration. *Journal of Management*, 32(5), 646–672. <https://doi.org/10.1177/0149206306290712>
- Lumpkin, G. T., & Lichtenstein, B. B. (2005). The role of organizational learning in the opportunity-recognition process. *Entrepreneurship Theory and Practice*, 29(4), 451–472. <https://doi.org/10.1111/j.1540-6520.2005.00093.x>
- Mainela, T., Puhakka, V., & Servais, P. (2014). The concept of international opportunity in international entrepreneurship: A review and a research agenda. *International Journal of Management Reviews*, 16(1), 105–129. <https://doi.org/10.1111/ijmr.12011>
- Majumdar, S. K. (1997). The impact of size and age on firm-level performance: Some evidence from India. *Review of Industrial Organization*, 12(2), 231–241. <https://doi.org/10.1023/A:1007766324749>
- March, J. G. (1991). Exploration and exploitation in organizational learning. *Organization Science*, 2(1), 71–87. <https://doi.org/10.1287/orsc.2.1.71>
- Meyer, A. D., Tsui, A. S., & Hinings, C. R. (1993). Configurational approaches to organizational analysis. *Academy of Management Journal*, 36(6), 1175–1195. <https://doi.org/10.5465/256809>
- Misangyi, V. F., & Acharya, A. G. (2014). Substitutes or complements? A configurational examination of corporate governance mechanisms. *Academy of Management Journal*, 57(6), 1681–1705. <https://doi.org/10.5465/amj.2012.0728>
- Mostafa, R., & Klepper, S. (2018). Industrial development through tacit knowledge seeding: Evidence from the Bangladesh garment industry. *Management Science*, 64(2), 613–632. <https://doi.org/10.1287/mnsc.2016.2619>
- Mostafiz, I., Sambasivan, M., & Goh, S. K. (2019a). The antecedents and the outcomes of foreign market knowledge accumulation – The dynamic managerial capability perspective. *Journal of Business and Industrial Marketing*, 34(4), 902–920. <https://doi.org/10.1108/JBIM-09-2018-0263>
- Mostafiz, I., Sambasivan, M., & Goh, S. K. (2019b). Impacts of dynamic managerial capability and international opportunity identification on firm performance. *Multinational Business Review*, 27(4), 339–363. <https://doi.org/10.1108/MBR-09-2018-0061>
- Mostafiz, I., Sambasivan, M., & Goh, S. K. (2019c). Measurement scale of international opportunity identification in early internationalization firms. *Asia-Pacific Journal of Business Administration*, 11(2), 131–145. <https://doi.org/10.1108/APJBA-10-2018-0179>
- Mostafiz, I., Sambasivan, M., & Goh, S. K. (2019d). Born global phenomenon: A critical review and avenues for future research. *European Journal of International Management*. (in press).
- Mostafiz, M. I., Sambasivan, M., & Goh, S. K. (2020). The performance of export manufacturing firms: Roles of international entrepreneurial capability and international opportunity recognition. *International Journal of Emerging Markets*. (early cite). <https://doi.org/10.1108/IJOEM-09-2019-0732>

- Mostafiz, M. I., Sambasivan, M., & Goh, S. K. (2021). Antecedents and consequences of market orientation in international B2B market: Role of export assistance as a moderator. *Journal of Business & Industrial Marketing*. (early cite). <https://doi.org/10.1108/JBIM-09-2019-0411>
- Mudambi, R., & Zahra, S. (2007). The survival of international new ventures. *Journal of International Business Studies*, 38(2), 333–352. <https://doi.org/10.1057/palgrave.jibs.8400264>
- Musteen, M., Datta, D. K., & Butts, M. M. (2014). Do international networks and foreign market knowledge facilitate SME internationalization? Evidence from the Czech Republic. *Entrepreneurship Theory and Practice*, 38(4), 749–774. <https://doi.org/10.1111/etap.12025>
- O'Connor, G.C. and Rice, M.P. (2001) 'Opportunity Recognition and Breakthrough Innovation in Large Established Firms, Vol. 43, No. 2, p.95. <https://doi.org/10.2307/41166077>
- Pacho, F. T. (2018). The effect of effectual entrepreneur set of means in opportunity exploitation capability. *International Journal of Innovative Science and Research Technology*, 3(3), 560–569. <https://doi.org/10.1108/JKM-01-2020-0052>
- Paoloni, M., Coluccia, D., Fontana, S., & Solimene, S. Knowledge management, intellectual capital and entrepreneurship: A structured literature review. (2020). *Journal of Knowledge Management*, 24(8), 1797–1818. (early cite). <https://doi.org/10.1108/JKM-01-2020-0052>
- Peiris, I. K., Akoorie, M., & Sinha, P. (2015). *Conceptualizing the process of opportunity identification in international entrepreneurship research*. Springer.
- Podsakoff, P. M., MacKenzie, S. B., Lee, J. Y., & Podsakoff, N. P. (2003). Common method biases in behavioral research: A critical review of the literature and recommended remedies. *Journal of Applied Psychology*, 88(5), 879–903. <https://doi.org/10.1037/0021-9010.88.5.879>
- Ragin, C. C. (2009). *Qualitative comparative analysis using fuzzy sets (fsQCA)*. Sage.
- Shane, S., & Venkataraman, S. (2000). The promise of entrepreneurship as a field of research. *Academy of Management Review*, 25(1), 217–226. <https://doi.org/10.5465/amr.2000.2791611>
- Sivadas, E., & Dwyer, F. R. (2000). An examination of organizational factors influencing new product success in internal and alliance-based processes. *Journal of Marketing*, 64(1), 31–49. <https://doi.org/10.1509/jmkg.64.1.31.17985>
- Taheri, B., Olya, H., Ali, F., & Gannon, M. J. (2019). Understanding the influence of airport servicescape on traveler dissatisfaction and misbehavior. *Journal of Travel Research*, 58(7), 1–21. <https://doi.org/10.1177/0047287519877257>
- Taymaz, E. (2005). Are small firms really less productive? *Small Business Economics*, 25(5), 429–445. <https://doi.org/10.1007/s11187-004-6492-x>
- Textile Today. (2016). Transformation of the textile and apparel industry of Bangladesh through innovation. *Industry Insight*. <https://www.textiletoday.com.bd/transformation-of-the-textile-and-apparel-industry-of-bangladesh-through-innovation/>
- Timmons, J. A., & Spinelli, S. (2006). *New venture creation for the 21st century* (7 ed.). McGraw Hill.
- Topader, R. A. (2018). *Brighter future for Bangladesh apparel industry*. from Independent Publications Limited. <http://www.theindependentbd.com/printversion/details/147102>
- Tripsas, M., & Gavetti, G. (2000). Capabilities, cognition, and inertia: Evidence from digital imaging. *Strategic Management Journal*, 21(10–11), 147–1161. [https://doi.org/10.1002/1097-0266\(200010/11\)21:10/11<1147::AID-SMJ128>3.0.CO;2-R](https://doi.org/10.1002/1097-0266(200010/11)21:10/11<1147::AID-SMJ128>3.0.CO;2-R)
- UNCTAD. (2015). *The Least Developed Countries Report 2015: Transforming Rural Economies*. United Nation. Retrieved from United State: <http://www.unctad.org>
- Vasilchenko, E., & Morrish, S. (2011). The role of entrepreneurial networks in the exploration and exploitation of internationalization opportunities by information and communication technology firms. *Journal of International Marketing*, 19(4), 88–105. <https://doi.org/10.1509/jim.10.0134>
- Venkataraman, S. (1997). The distinctive domain of entrepreneurship research. *Advances in Entrepreneurship, Firm Emergence and Growth*, 3(1), 119–138.
- Wang, Y. L., Ellinger, A. D., & Wu, Y. C. J. (2013). Entrepreneurial opportunity recognition: An empirical study of R&D personnel. *Management Decision*, 51(2), 248–266. <https://doi.org/10.1108/00251741311301803>
- Wei, Z., Hou, J., Wang, D., & Wang, L. (2011). How can SMEs leverage political ties and technological innovation capability to acquire government assistance in a transition economy. *Journal of General Management*, 36(4), 3–22. <https://doi.org/10.1177/030630701103600402>
- Woodside, A. G. (2014). Embrace• perform• model: Complexity theory, contrarian case analysis, and multiple realities. *Journal of Business Research*, 67(12), 2495–2503. <https://doi.org/10.1016/j.jbusres.2014.07.006>
- Zahra, S., Hayton, J., Marcel, J., & O'Neill, H. (2001). Fostering entrepreneurship during international expansion: Managing key challenges. *European Management Journal*, 19(4), 359–369. [https://doi.org/10.1016/S0263-2373\(01\)00037-8](https://doi.org/10.1016/S0263-2373(01)00037-8)
- Zahra, S. A., Ireland, D. R., & Hitt, M. A. (2000). International expansion by new venture firms: International diversity, mode of market entry, technological learning, and performance. *Academy of Management Journal*, 43(5), 925–950. <https://doi.org/10.5465/1556420>
- Zahra, S. A., Korri, J. S., & Yu, J. (2005). Cognition and international entrepreneurship: Implications for research on international opportunity recognition and exploitation. *International Business Review*, 14(2), 129–146. <https://doi.org/10.1016/j.ibusrev.2004.04.005>
- Zhou, L. (2007). The effects of entrepreneurial proclivity and foreign market knowledge on early internationalization. *Journal of World Business*, 42(3), 281–293. <https://doi.org/10.1016/j.jwb.2007.04.009>