

PLINIAN CORE PROFILES

*Facilitating the
documentation and
access to biological
information of exotic
and invasive species*

TDWG 2016
Annual Conference
Santa Clara de San Carlos,
Costa Rica – December 5-9

Leonardo Buitrago,
Nestor Beltran, Marcela
Delgado, Valerie Dean,
Dairo Escobar

Instituto Humboldt
SiB Colombia



© Brian Gratwicke

About SiB Colombia

- *Colombian Biodiversity Information System*
- National initiative established in early 2000 and coordinated by the Humboldt Institute.
- Mission:
 - **To facilitate free and open access to biodiversity data.**
- Making Colombia's biodiversity information more accessible and usable online.



Species Information

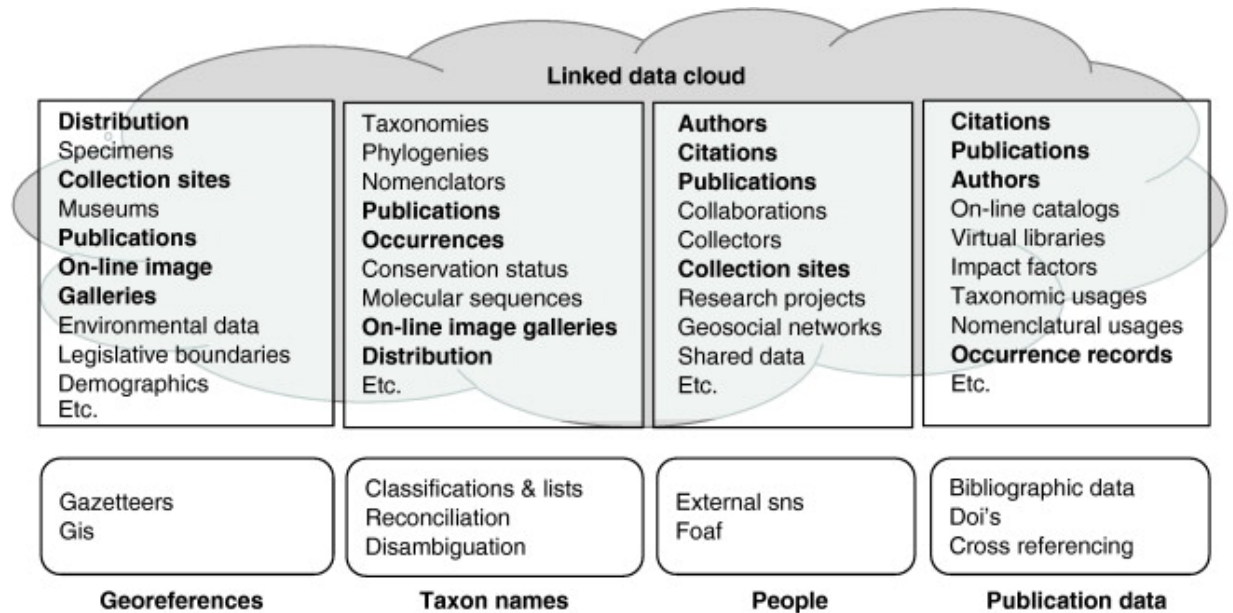

TRENDS in Ecology & Evolution

(Patterson D. J. et al, 2010)

“So pity the taxonomists, who have yet to organize something equivalent for their field: a comprehensive, well-funded, highly coordinated effort to count and describe Earth's species.” (Lawer A., 2001).

Species Information

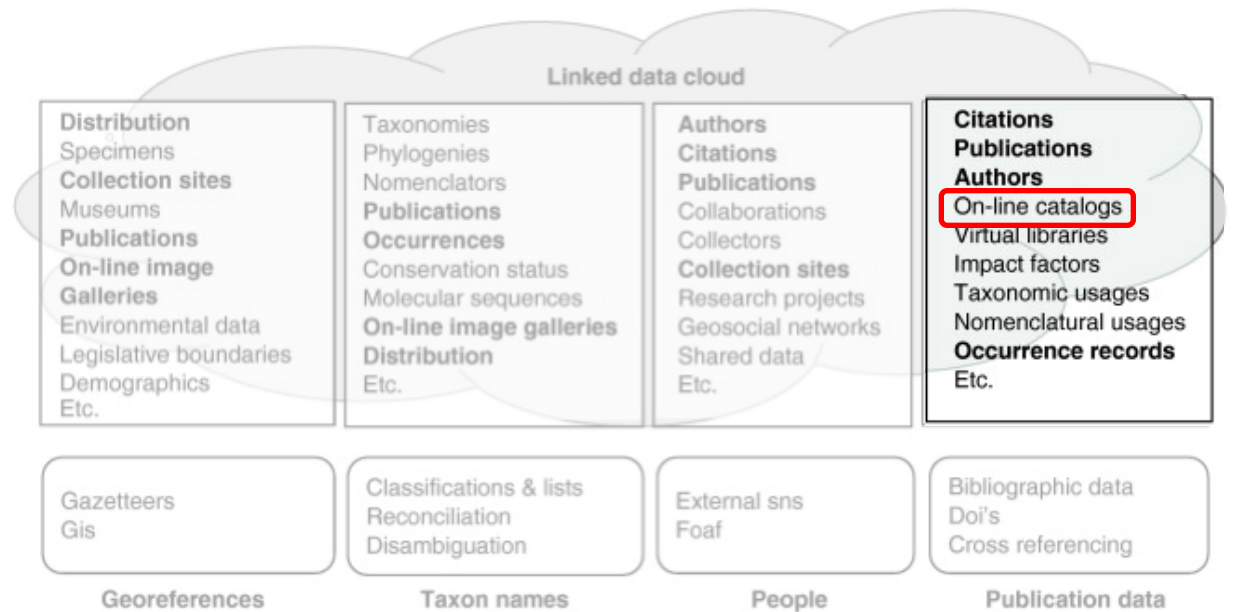

TRENDS in Ecology & Evolution

(Patterson D. J. et al, 2010)

“So pity the taxonomists, who have yet to organize something equivalent for their field: a comprehensive, well-funded, highly coordinated effort to count and describe Earth's species.” (Lawer A., 2001).

On-line catalogs

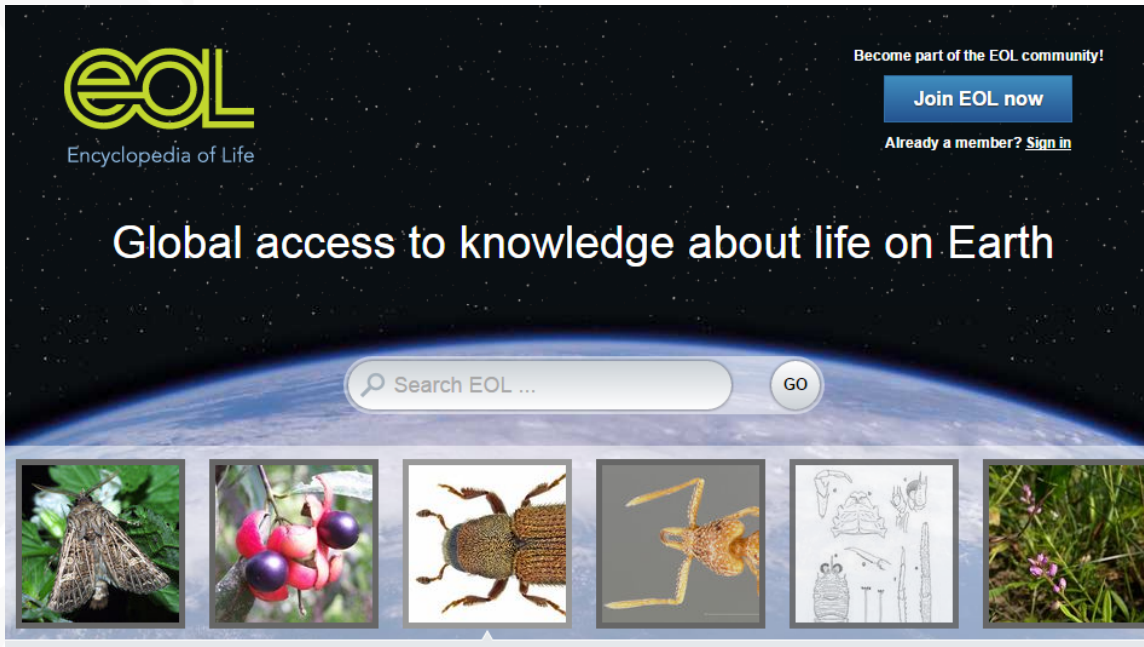

eol.org

Citations
Publications
Authors
On-line catalogs
Virtual libraries
Impact factors
Taxonomic usages
Nomenclatural usages
Occurrence records
Etc.

“The magnitude of biodiversity and the tangle of evolutionary processes that generated it still present formidable problems.”
(Wilson E, 2003).

On-line catalogs

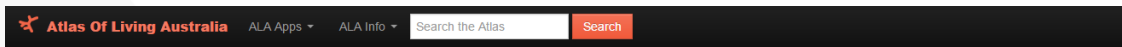

Australia's Species

Browse Iconic Australian species

- Birds (23) >
- Conifers (2) >
- Ferns (6) >
- Fish (12) >
- Flowering plants (19) >
- Frogs (7) >
- Fungi (5) >
- Invertebrates (18) >
- Mammals (19) >
- Reptiles (25) >



- Citations
- Publications
- Authors
- On-line catalogs**
- Virtual libraries
- Impact factors
- Taxonomic usages
- Nomenclatural usages
- Occurrence records**
- Etc.

“The magnitude of biodiversity and the tangle of evolutionary processes that generated it still present formidable problems.”
(Wilson E, 2003).

lists.ala.org.au/iconic-species

On-line catalogs

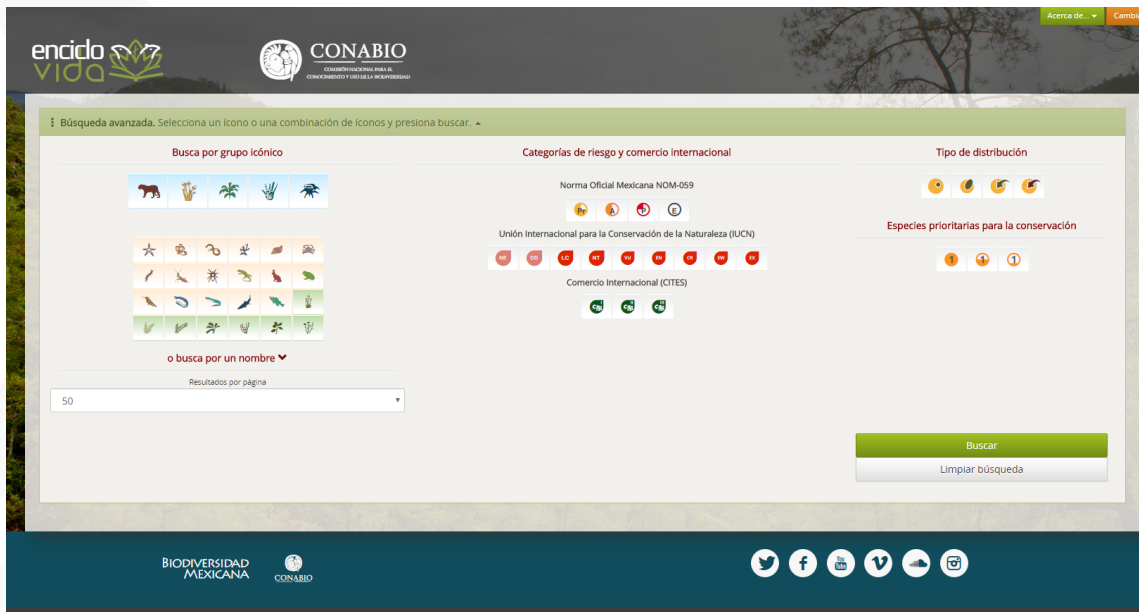

- Citations
- Publications
- Authors
- On-line catalogs**
- Virtual libraries
- Impact factors
- Taxonomic usages
- Nomenclatural usages
- Occurrence records
- Etc.

“The magnitude of biodiversity and the tangle of evolutionary processes that generated it still present formidable problems.”
(Wilson E, 2003).

enciclovida.mx

On-line catalogs

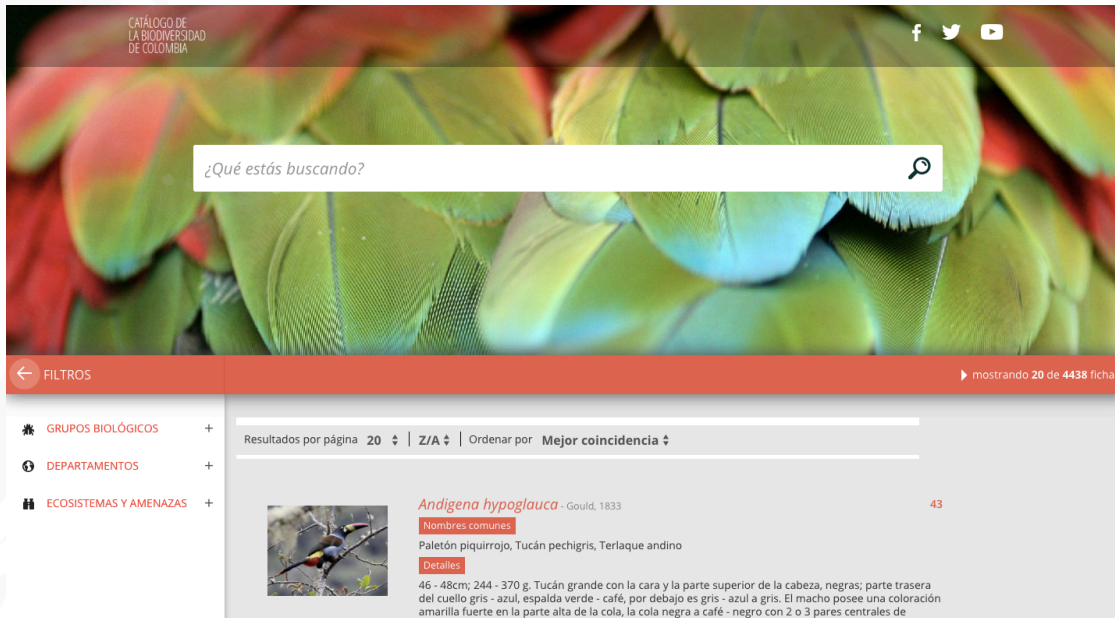

- Citations
- Publications
- Authors
- On-line catalogs**
- Virtual libraries
- Impact factors
- Taxonomic usages
- Nomenclatural usages
- Occurrence records
- Etc.

“The magnitude of biodiversity and the tangle of evolutionary processes that generated it still present formidable problems.”
(Wilson E, 2003).

catalogo.biodiversidad.co

Species Attributes



Species Attributes



Morphology

© Rossie, 2002, available at http://dijimo.rph.org/specimens/Saimiri_sciureus/338948

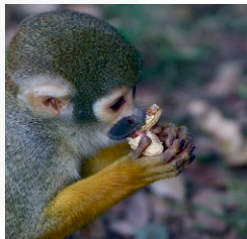

(CC BY-NC 2.0) Wade Tregaskis

Feeding

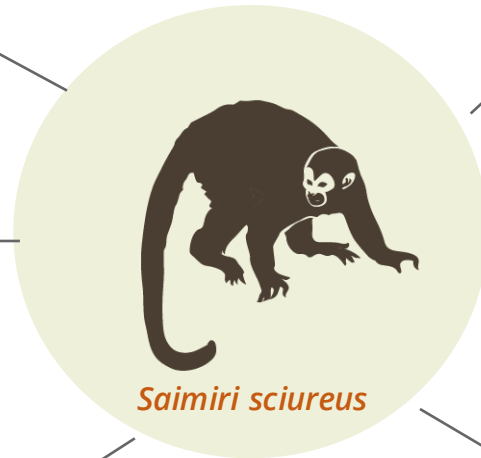

Saimiri sciureus

Taxonomy

- [Animalia +](#)
- [Chordata +](#)
- [Mammalia +](#)
- [Primates +](#)
- [Cebidae +](#)
- [Saimiri +](#)
- [Saimiri sciureus \(Linnaeus, 1758\)](#)
- [Saimiri boliviensis \(I. Geoffroy Saint-Hilaire and Blainville, 18](#)
- [Saimiri oerstedii \(Reinhardt, 1872\)](#)
- [Saimiri ustus \(I. Geoffroy Saint-Hilaire, 1843\)](#)
- [Saimiri vanzolinii Ayres, 1985](#)

Distribution

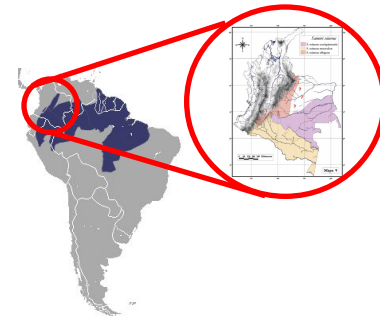

Habitat



(CC BY-NC-ND 2.0) Marco Parra

Conservation status



Interoperability between Catalogs

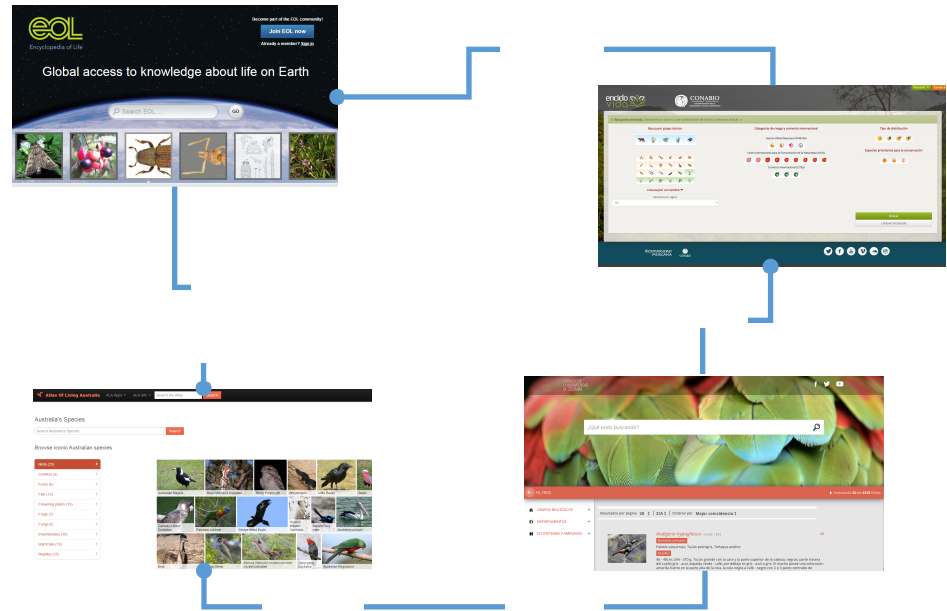

Common issues



Saimiri sciureus

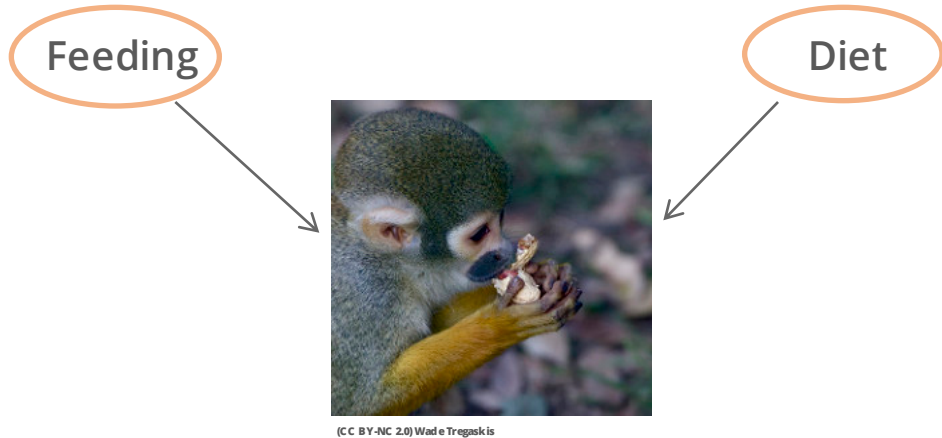

Two terms refer to the same concept

Common issues



Saimiri sciureus

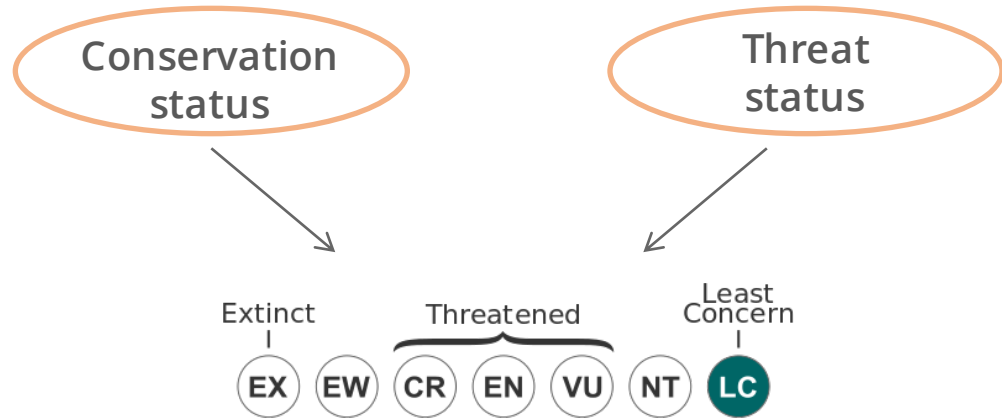

Two terms refer to the same concept

Common issues



Fuente: INBio
© Derechos reservados

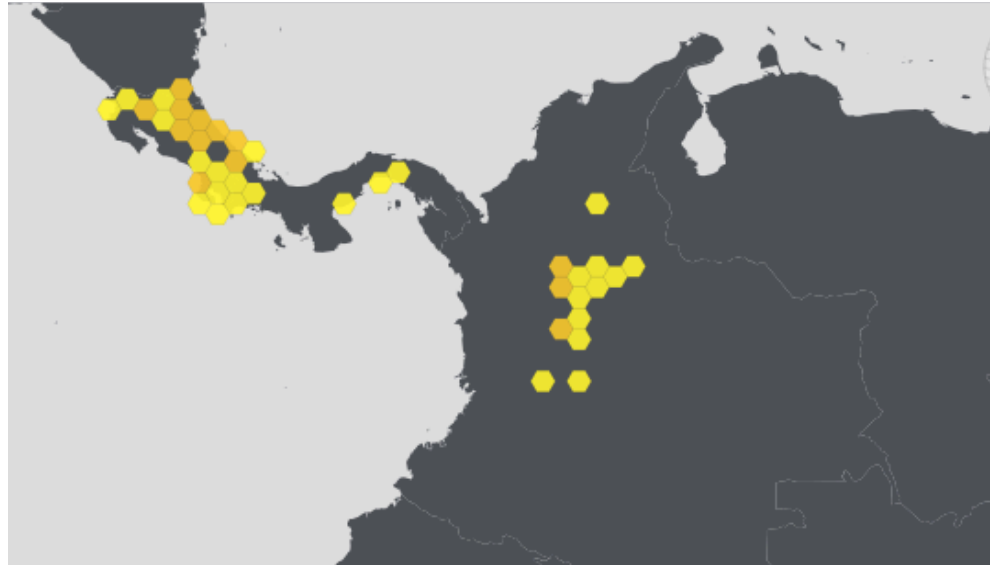

Isolated information about species

Lepidoblepharis xanthostigma

Plinian core (PliC)

Standardized and facilitate the exchange of information about the species and upper taxa



PLINIAN CORE
SPECIES INFO PROFILE

Species level catalogs of any kind of biological objects or data

Terminology associated with biological collection data

Compatibility with other biodiversity-related standards

Facilitating the addition of components and attributes of biological data

PLiC - History

Standardized and facilitate the exchange of information about the species and upper taxa



Biodiversity
Information
Standards
T D W G

**SPECIES INFORMATION
INTEREST GROUP**

2005

2013



Plinian core

Its **hierarchical schema** allows to develop species pages that can be integrated in many contexts.

>Abstract Model [Abstract Model v3.2.1]



PLINIAN CORE
SPECIES INFO PROFILE

CATEGORIES



- Plinian Core Terms
 - Dataset
 - Metadata
 - Dataset_ID
 - dateStamp
 - citation
 - dataset
 - resourceLogoUrl
 - References
 - TaxonRecord
 - RecordMetadata
 - BaseElements
 - NomenclatureAndClassification
 - TaxonomicDescription
 - NaturalHistory
 - Invasiveness
 - HabitatAndDistribution
 - DemographyAndThreat
 - UsesManagementAndConservation
 - associatedParty
 - References
 - AncillaryData
 - AncillaryData

<https://github.com/PlinianCore>

PliC Schema

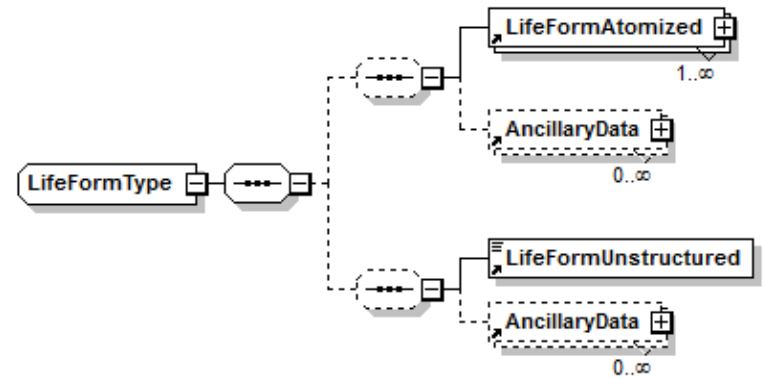

Category → Natural History

Class → (LifeForm) > MeasurementOrFact | LifeFormUnstructured ← Element

Atomized

Unstructured

PliC Schema

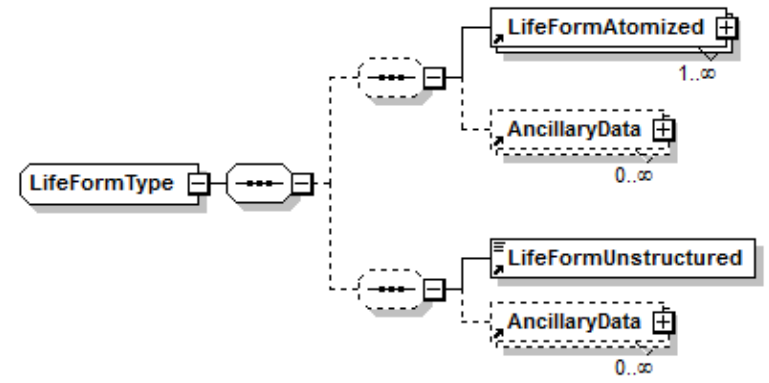

Category → Natural History

Class → (LifeForm) > MeasurementOrFact | LifeFormUnstructured

Controlled vocabulary

- *Phanerophyte*
- *Nanophanerophyte*
- *Herbaceous phanerophyte*
- *Chamaephyte*
- *Hemicryptophyte*
- *Geophyte*
- *Therophyte*
- *Epiphyte*
- *Helophyte*
- *Hydrophyte*

Free text

It is a shrub of 3 to 5 m of height, branched from the base, with surface root and resistant and dioecious flowers.

PliC Core SiB Colombia Application Profile

Abstract Model → AP_SiB-Colombia v3.2.1

- ✓ Only uses a subset of all available elements
- ✓ Controlled vocabularies mandatories

```
<xs:complexType>  
  <xs:sequence>  
    <xs:element ref="BaseElements"/>  
    <xs:element ref="Language" minOccurs="0"/>  
    <xs:element ref="Version"/>  
    <xs:element ref="Revision" minOccurs="0" maxOccurs="unbounded"/>  
    <xs:element ref="TaxonRecordName"/>  
    <xs:element ref="SynonymsAtomized" minOccurs="0" maxOccurs="unbounded"/>  
    <xs:element ref="CommonNamesAtomized" minOccurs="0" maxOccurs="unbounded"/>  
    <xs:element ref="Hierarchy" minOccurs="0" maxOccurs="unbounded"/>  
    <xs:element ref="BriefDescription" minOccurs="0"/>  
    <xs:element ref="FullDescription" minOccurs="0"/>  
    <xs:element ref="IdentificationOnly" minOccurs="0"/>  
    <xs:element ref="LifeForm" minOccurs="0"/>  
    <xs:element ref="Lifecycle" minOccurs="0"/>  
    <xs:element ref="Reproduction" minOccurs="0"/>  
    <xs:element ref="AnnualCycles" minOccurs="0"/>  
    <xs:element ref="Feeding" minOccurs="0"/>  
    <xs:element ref="Dispersal" minOccurs="0"/>  
    <xs:element ref="Behavior" minOccurs="0"/>  
    <xs:element ref="Interactions" minOccurs="0"/>  
    <xs:element ref="MolecularData" minOccurs="0"/>  
    <xs:element ref="Migratory" minOccurs="0"/>  
    <xs:element ref="EcologicalSignificance" minOccurs="0"/>  
    <xs:element ref="EnvironmentalEnvelope" minOccurs="0"/>  
    <xs:element ref="Invasiveness" minOccurs="0"/>  
    <xs:element ref="Habitats" minOccurs="0"/>  
    <xs:element ref="Distribution" minOccurs="0" maxOccurs="unbounded"/>  
    <xs:element ref="EndemicAtomized" minOccurs="0"/>  
    <xs:element ref="Territory" minOccurs="0"/>  
    <xs:element ref="PopulationBiology" minOccurs="0"/>  
    <xs:element ref="ThreatStatus" minOccurs="0" maxOccurs="unbounded"/>  
    <xs:element ref="DirectThreats" minOccurs="0"/>  
    <xs:element ref="Legislation" minOccurs="0"/>  
    <xs:element ref="UsesAtomized" minOccurs="0" maxOccurs="unbounded"/>  
    <xs:element ref="ManagementAndConservation" minOccurs="0"/>  
    <xs:element ref="associatedParty" minOccurs="0" maxOccurs="unbounded"/>  
    <xs:element ref="MeasurementOrFact" minOccurs="0" maxOccurs="unbounded"/>  
    <xs:element ref="References" minOccurs="0"/>  
    <xs:element ref="DetailAtomized" minOccurs="0" maxOccurs="unbounded"/>  
    <xs:element ref="AncillaryData" minOccurs="0" maxOccurs="unbounded"/>  
  </xs:sequence>
```

Atomized

Unstructured

Atomized

Additional restrictions SiB Colombia Application Profile

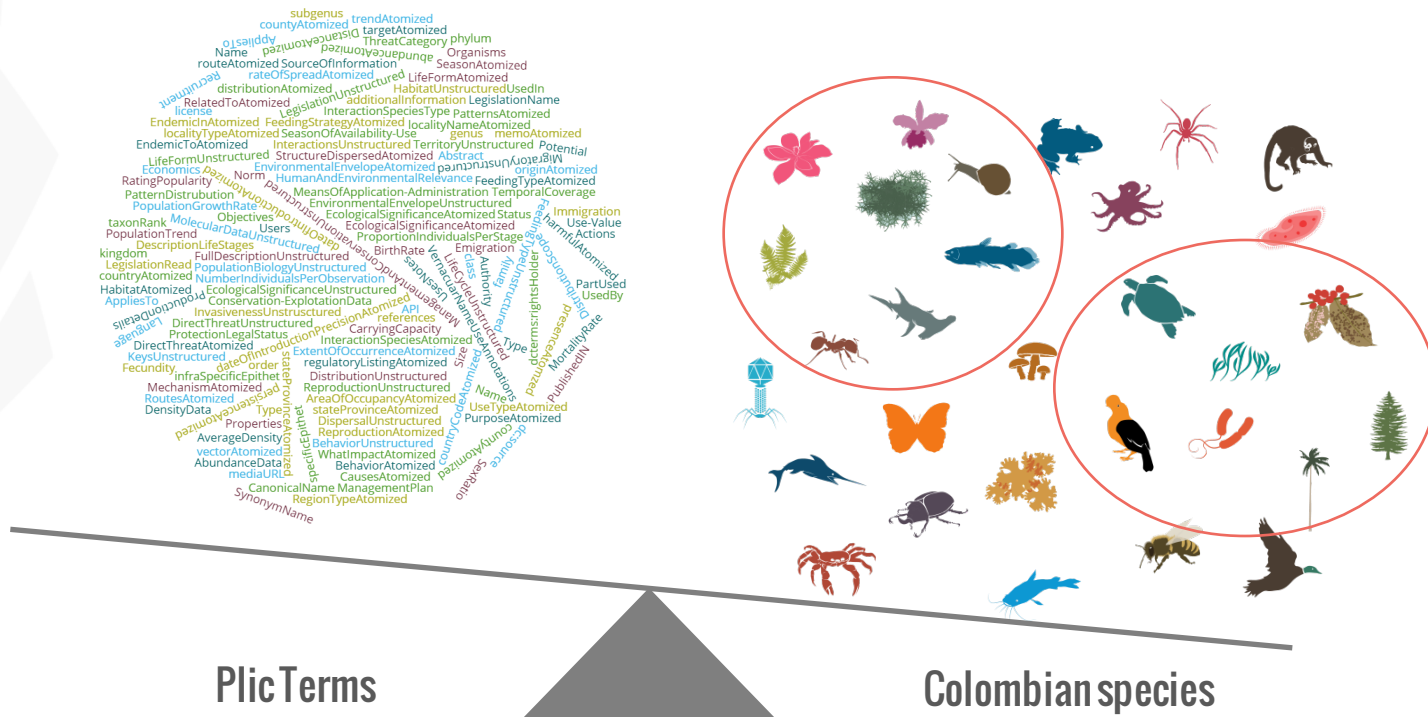

Invasive Species profile requirements - Colombia

A **guideline** to document **alien invasive species information**

- **Priority attributes** for risk analysis of invasion by exotic species
- The **establishment of categories and methodologies** for risk analysis of introduced, or alien species.
- **Support instrument** for different management processes and for **decision making**, such as invasion risk assessments following the general guidelines of the methodologies already applied in Colombia

Plinian Core Invasive species profile

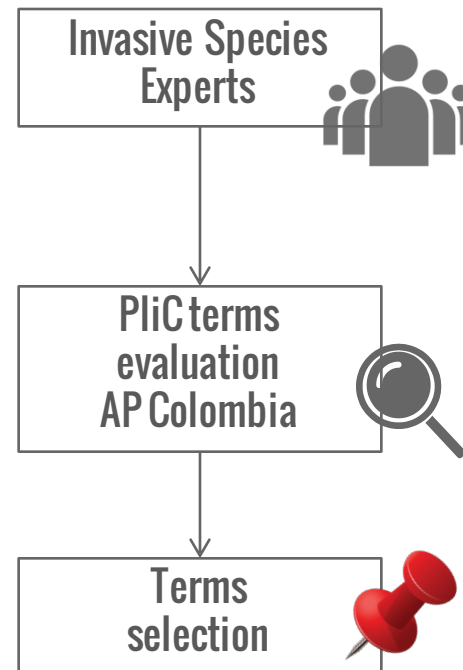

Plinian Core Invasive species profile



46 PlIC Terms
22 PlIC Classes



CATEGORY	PlIC Class
NOMENCLATURE & CLASSIFICATION	Scientific Name
	Hierarchy
	Synonyms
	Common Names
BASE ELEMENTS	Abstract
TAXONOMIC DESCRIPTION	Full Description
NATURAL HISTORY	Life Form <i>(* mainly for plants)</i>
	Life Cycle
	Reproduction
	Feeding
	Dispersal
	Molecular Data
	Migratory <i>(* mainly for animals)</i>
INVASIVENESS	Ecological Significance
	Environmental Envelope
	Invasiveness <i>(* According to GISIN terms)</i>
HABITAT & DISTRIBUTION	Habitat
	Distribution
USES, MANAGEMENT & CONSERVATION	Uses
	Management Plan
REFERENCES	Management & Conservation
ANCILLARY DATA	<i>Dublin Core</i>
	Additional Information

Plinian Core Invasive species profile



46 PlIC Terms
22 PlIC Classes

CATEGORY	PlIC Class	
NOMENCLATURE & CLASSIFICATION	Scientific Name	
	Hierarchy	
	Synonyms	
	Common Names	
BASE ELEMENTS	Abstract	
TAXONOMIC DESCRIPTION	Full Description	
	Life Form <i>(* mainly for plants)</i>	
NATURAL HISTORY	Life Cycle	
	Reproduction	
	Feeding	
	Dispersal	
	Molecular Data	
	Migratory <i>(* mainly for animals)</i>	
	Ecological Significance	
	Environmental Envelope	
	INVASIVENESS	Invasiveness <i>(* According to GISIN terms)</i>
	HABITAT & DISTRIBUTION	Habitat
Distribution		
USES, MANAGEMENT & CONSERVATION	Uses	
	Management Plan	
REFERENCES	Management & Conservation	
ANCILLARY DATA	<i>Dublin Core</i>	
	Additional Information	

= 83 Species pages



Plinian Core Threatened species profile



26 PlIC Classes



CATEGORY	PlIC Class
NOMENCLATURE & CLASSIFICATION	Scientific Name
	Hierarchy
	Synonyms
BASE ELEMENTS	Common Names
TAXONOMIC DESCRIPTION	Abstract
NATURAL HISTORY	Full Description
	Life Form <i>(* mainly for plants)</i>
	Life Cycle
	Reproduction
	Feeding
	Dispersal
	Molecular Data
	Migratory <i>(* mainly for animals)</i>
HÁBITAT Y DISTRIBUCIÓN	Ecological Significance
	Environmental Envelope
	Habitat
	Distribution
DEMOGRAPHY & THREAT	Endemic
	Population Biology
	Threat Status
	Direct Threats
USES, MANAGEMENT & CONSERVATION	Legislation
	Uses
REFERENCES	Management & Conservation
ANCILLARY DATA	<i>Dublin Core</i>
	Additional Information

= 235 Species pages



Associated results

✓ Two Guidelines

Guía para la publicación de registros biológicos y fichas de taxones de especies exóticas e invasoras



Volumen 2: Herramienta para la documentación de información sobre especies exóticas e invasoras

Esta herramienta de publicación fue desarrollada por el Centro de Estudios Ambientales SIB
Autores: Carolina M. Rojas, M. F. Castellanos, C. Botica, N. Rodríguez, J. Díaz, J. Rodríguez, M. Herrera, S. G. Figueroa, D. Acosta, P. Rodríguez

Contenidos

ÍNDICE DE SIGLAS

INTRODUCCIÓN

Utilidad y alcances de esta guía
Importancia de la publicación de datos e información sobre especies exóticas e invasoras
Algunos aspectos del país de destino: hitos prioritarios para los análisis de riesgo de invasión por especies exóticas

PARTE I: PUBLICACIÓN DE REGISTROS BIOLÓGICOS DE ESPECIES EXÓTICAS E INVASORAS

Conceptos básicos

¿Qué es un registro biológico y cuál es su importancia en la gestión de especies exóticas e invasoras?
¿Cuál es el estándar recomendado para la estructuración de conjuntos de datos de registros biológicos?



Guía para la publicación de registros biológicos y fichas de taxones de interés para la conservación



Volumen 1: Información para el análisis de riesgo de extinción de especies

Esta herramienta de publicación fue desarrollada por el Centro de Estudios Ambientales SIB
Autores: Carolina M. Rojas, M. F. Castellanos, C. Botica, N. Rodríguez, J. Díaz, J. Rodríguez, M. Herrera, S. G. Figueroa, D. Acosta, P. Rodríguez

Contenidos

ÍNDICE DE SIGLAS

INTRODUCCIÓN

Objetivo y alcances de esta guía

Importancia de la publicación de datos e información sobre biodiversidad
Factores importantes para documentar campañas prioritarias para los análisis de riesgo de extinción de especies

Objetivos y Criterios de la Lista Roja de la UICN

PARTE I: PUBLICACIÓN DE REGISTROS BIOLÓGICOS DE ESPECIES EXÓTICAS E INVASORAS

Conceptos básicos

¿Qué es un registro biológico y cuál es su importancia en la gestión de especies exóticas e invasoras?
¿Cuál es el estándar recomendado para la estructuración de conjuntos de datos de registros biológicos?
Campaña de documentación de especies y estudios de caso siguiendo el estándar Darwin Core

- Elementos de base
- Elementos geográficos
- Elementos taxonómicos



THREATENED SPECIES

INVASIVE SPECIES



Conclusions

- Online catalogs can significantly improve their capabilities if they share the same specifications
- The Plinian Core maximizes its potential and reach in its stages of development and implementation by involving experts from different biological groups of interest.
- The construction of different species profiles in PliC provide flexibility to attend different user needs while maintaining interoperability among them.

Acknowledgements

Research Institute of Biological Resources Alexander von Humboldt for the funding

All my team from The Colombian Biodiversity Information System

Entities that works from the beginning on PliC
GBIF Spain, INBIO

Paco Pando and Santiago Martinez de la Riva for all the work on the documentation on GitHub and all technical and scientific support

TDWG for the opportunity to present this work



facebook/sibcolombia



Twitter/sibcolombia



youtube/sibcolombia

Gracias!



Leonardo Buitrago

Researcher – Content Management

albuitrago@humboldt.org.co

www.sibcolombia.net

