



2011

Neuroendocrine Consequences of Binge Alcohol Exposure During Peri-Puberty on Functioning of the Hypothalamo-Pituitary-Adrenal (HPA) Axis

Magdalena Malgorzata Przybycien-Szymanska
Loyola University Chicago

Recommended Citation

Przybycien-Szymanska, Magdalena Malgorzata, "Neuroendocrine Consequences of Binge Alcohol Exposure During Peri-Puberty on Functioning of the Hypothalamo-Pituitary-Adrenal (HPA) Axis" (2011). *Dissertations*. Paper 190.
http://ecommons.luc.edu/luc_diss/190

This Dissertation is brought to you for free and open access by the Theses and Dissertations at Loyola eCommons. It has been accepted for inclusion in Dissertations by an authorized administrator of Loyola eCommons. For more information, please contact ecommons@luc.edu.



This work is licensed under a [Creative Commons Attribution-Noncommercial-No Derivative Works 3.0 License](https://creativecommons.org/licenses/by-nc-nd/3.0/).
Copyright © 2011 Magdalena Malgorzata Przybycien-Szymanska

LOYOLA UNIVERSITY CHICAGO

NEUROENDOCRINE CONSEQUENCES OF BINGE ALCOHOL
EXPOSURE DURING PERI-PUBERTY ON FUNCTIONING OF THE
HYPOTHALAMO-PITUITARY-ADRENAL (HPA) AXIS

A DISSERTATION SUBMITTED TO
THE FACULTY OF THE GRADUATE SCHOOL
IN CANDIDACY FOR THE DEGREE OF
DOCTOR OF PHILOSOPHY

PROGRAM IN NEUROSCIENCE

BY

MAGDALENA M. PRZYBYCIEN-SZYMANSKA

CHICAGO, IL

AUGUST 2011

Copyright by Magdalena M. Przybycien-Szymanska, 2011
All rights reserved

ACKNOWLEDGEMENTS

It wasn't an easy journey up to this point and I would not be able to make it without the help of my family and friends. I want to start with thanking my husband, whom I met at the beginning of my graduate school career and who never gave up encouraging me to keep going. Many times when I complained, he said "Nobody forced you into it. It was your choice so stop complaining and keep going!" As harsh as it sounds, it helped me overcome all the obstacles and made me realize that becoming a scientist is what I really want in life. He encouraged and supported me no matter how hard the time was. When I wanted to quit, he said "Right now, school is the most important thing for you. Everything else is going to fall into place. Don't worry! Everything will be OK" Thank you, Marcin, for making me laugh in stress, for surrounding me with your arm when I felt bad, for lending me your arm to cry on when I needed it, for laughing at me when I cried too much and for being there for me throughout all these years, through better and worse!

I also want to thank my parents, Marta and Marek and my grandmother, Barbara, who supported me all through my education, from the kindergarten until now. My parents kept on assuring me that no matter what I chose to do in life; it would be a good choice. They did not let me give up at any stage. Mom and Dad, thank you for letting me choose my own path in life. Thank you for supporting me

all the way through, thank you for helping me become a better person and thank you for coming to the US with me so that I can study here and have more options than I would have at home. Thank you for that because I know that you came here only for me and it was not an easy decision for you.

Grandma, you were there for me from the first day of school. I will never forget the first day of elementary school when you went with me, held me by my hand and helped me start my education. Now you are here with me, 22 years later, at the end of my official education, still holding my hand and entering the “real life” with me. Thank you for going with me through that journey and thank you for all these delicious pierogie, paczki, and other goodies that kept me nutritious throughout my education.

I cannot give enough thanks to Toni, my advisor and my friend. She was not only a great mentor who was able to pass along all her knowledge about science and life onto me, who not only helped me in being a great scientist but in being a better person as well. Toni, you taught me one lesson I will never forget. You said: “My motto in life is to be the best person I can possibly be.” I know that this quote from you is going to stay with me throughout all my life. Thank you for giving me encouragement and support, for telling me that I cannot do all these experiments I would like to do because you would go bankrupt if I did and it would take me 20 years to graduate, for being so supportive when I was going through some rough moments of rejection or failure, for spending numerous hours with me going over my many presentations, for being patient in correcting all my typos and articles and thank you for not letting me give up. I think that you

are the best mentor I could possibly have chosen and I hope you are going to be my mentor and friend throughout the rest of my life.

There are many other people who helped me survive in graduate school and I apologize if I am not able to name you all but you are always going to be in my heart. Thank you, Natasha, for all the hugs when I cried and for all the laughs we shared. Thank you for keeping me on my toes and teaching me transfections. Thank you, Roberta for all of your help with animals and a warm word of encouragement when I needed it. Thank you Sarah for being so nice and supportive ever since you joined the lab. Thank you Yathi for saving my experiments when I thought that I will not be able to finish them due to equipment problem. Thank you Caitlin for being a great office mate and for making each day brighter. Thanks Natasha, Yathi, Sarah, Caitlin, and Roberta for all the fun times we had. Life in the lab would not be the same without you all. I would also like to thank my friends, Dr. Betty Lorenz, Dr. Sara Sarkey, Dr. Sarah Kohler and Dr. Cinthia von Zee for supporting me with a good advice even after you were all done with your education. Thanks for all the fun outings and for keeping on giving me a good advice and encouragement to keep going. You are all great friends to have.

I would also like to thank my committee members, Dr. Lydia DonCarlos, Professor in the Cell and Molecular Physiology Department, Dr. John Callaci, Assistant Professor, Orthopedic Surgery and Rehabilitation Department, Dr. George Battaglia, Professor in the Pharmacology Department, and Dr. Mary Manteuffel, Professor in the Cell and Molecular Physiology Department, Loyola

University Chicago. Thank you for all your guidance and support throughout the course of my project. Dr. Manteuffel for spending your time helping me improve my presentation. Dr. Callaci for helping me develop my experimental model and Dr. Battaglia for helping me with the ACTH assay. Dr. DonCarlos, thank you for staying with me even after I was done with my Masters Thesis in your laboratory and for serving on my PhD committee. Thank you for your advice and for being a person I could always go to and talk.

Thank you everyone for your support!!!

Finally, I would like to take a moment to acknowledge all who helped me with various methods and provided materials for this project. First of all, I would like to thank Francisca Garcia, Pharmacology Departments, Loyola University Medical Center, for help with ACTH radioimmunoassay. Dr. James Sinacore, for being extremely patient with answering endless statistics questions I had. Dr. John Kaskow (University of Cincinnati) for providing IVB cells, Dr. Audrey F. Seasholtz (University of Michigan, Ann Arbor, MI) for the CRH promoter and taxpayers and National Institute of Health for funding the experiments.

TABLE OF CONTENTS

ACKNOWLEDGMENTS	iii
LIST OF TABLES	x
LIST OF FIGURES	xi
LIST OF ABBREVIATIONS	xiv
ABSTRACT	xvi
CHAPTER ONE: INTRODUCTION	1
Literature Review	1
Binge alcohol consumption in adolescents	1
Brain development during adolescence	2
Fetal brain development and the effects of in utero alcohol exposure	3
The hypothalamo-pituitary-adrenal (HPA) axis	5
Paraventricular nucleus of the hypothalamus (PVN). Outputs and Inputs	6
Pituitary gland and its functions	9
Adrenals and their functions	11
Glucocorticoid mediated negative feedback in the PVN	12
Role of arginine vasopressin (AVP) in the regulation of the HPA axis	13
Pubertal maturation of the HPA axis	15
Dysregulation of the HPA axis and mood disorders	17
Sex differences in the HPA axis reactivity to stressor	19
Chronic stress and hypoactivity of the HPA axis	21
Alcohol abuse and relationship to mood disorders	22
Alcohol exposure during puberty and its long lasting effects	24
Summary	25
Next step in alcohol research	26
Hypothesis and Aims	27
CHAPTER TWO: BINGE-PATTERN ALCOHOL EXPOSURE DURING PUBERTY INDUCES SEXUALLY DIMORPHIC CHANGES IN GENES REGULATING THE HPA AXIS (PRZYBYCIEN-SZYMANSKA MM ET AL. AM. J OF PHYSIOL. ENDOCRINOL AND METAB. 2010)	35
Introduction	35

Results	38
Discussion	53
CHAPTER THREE: ALCOHOL DYSREGULATES CORTICOTROPHIN- RELEASING-HORMONE (CRH) PROMOTER ACTIVITY BY INTERFERING WITH NEGATIVE GLUCOCORTICOID RESPONSE ELEMENT SITE	
	64
Introduction	64
Results	68
Discussion	86
CHAPTER FOUR: ROLE OF ESTRADIOL IN THE HYPOTHALAMO- PITUITARY-ADRENAL (HPA) AXIS RESPONSIVENESS OF PERI- PUBERTAL FEMALE RATS TO BINGE ALCOHOL EXPOSURE	
	94
Introduction	94
Results	97
Discussion	114
CHAPTER FIVE: BINGE-PATTERN ALCOHOL EXPOSURE DURING PUBERTY INDUCES LONG-TERM CHANGES IN HPA AXIS REACTIVITY (PRZYBYCIEN-SZYMANSKA MM. ET AL., PLOS ONE, APRIL 2011)	
	124
Introductio	124
Results	126
Discussion	142
CHAPTER SIX: FINAL DISCUSSION	
	152
Summary	152
Final considerations	157
Future direction	161
Take home message	166
CHAPTER SEVEN: GENERAL METHODS	
	167
Animals	167
Binge alcohol exposure paradigm	167
Blood alcohol concentration (BAC) measurements	168
Hormone measurements	169
Tissue collection and qRT-PCR	171

qRT-PCR for glucocorticoid receptor (GR) expression in IVB cells	174
Cell culture	174
Reporter gene constructs and expression vectors	175
Transient Transfections and Dual Luciferase Assay	175
Alcohol and hormone treatments	176
Site directed mutagenesis	177
In Vitro Toxicology Assay (MTT based)	178
Statistical analysis	179
REFERENCES	180
VITA	201

LIST OF TABLES

Table	Page
1. Summary of EtOH induced effects in different CRH promoter construct	85
2. Schematic representation of treatment groups used 1	100
3. Experimental design 2	128
4. Summary of major findings	154

LIST OF FIGURES

Figure	Page
1. Schematic representation of the hypothesis proposed	28
2. Binge alcohol exposure paradigm employed in my studies	40
3. Effects of ethanol treatment on body weight during pubertal development (post natal day (PND) 37-44)	42
4. Effects of EtOH treatments on blood alcohol levels in male and female rats	44
5. Effects of EtOH treatment on gonadal steroid hormone levels	46
6. Effects of EtOH treatments on blood corticosterone levels in male and female rats	48
7. Effects of EtOH treatments on CRH and AVP gene expression in the PVN of male and female rats	50
8. Effects of EtOH treatments on AVP gene expression in the SON of male and female rats	52
9. Summary of results described in Chapter 2	55
10. Schematic model describing regulation of CRH promoter	67
11. Effects of 100 mM EtOH treatment on cell viability in a neuronal cell line	70
12. Effects of EtOH treatment (A) and RU486 pre-treatment (B) on CRH promoter activity in a neuronal cell line	72
13. Effects of 0.5 h or 2.0 h EtOH treatment on the GR mRNA expression in IVB cell line	64
14. Effects of 2.0 h EtOH treatment with different doses of EtOH on CRH promoter activity	76

15. Schematic representation of the CRH promoter deletions used in these experiments	78
16. Effects of Forskolin treatment on WT and mutated CRH promoter activity	80
17. Effects of EtOH treatment on WT and mutated CRH promoter reactivity	84
18. Schematic model describing EtOH effects on the CRH promoter	87
19. Effects of ethanol treatment on body weight of ovariectomized females replaced either with Ch or E ₂ during pubertal development	102
20. Effects of EtOH treatments on blood alcohol levels in ovariectomized female rats	104
21. Effects of EtOH treatments on blood ACTH and CORT levels in ovariectomized female rats replaced with Ch or E ₂	107
22. Effects of EtOH treatments on CRH and AVP gene expression in the PVN of ovariectomized female rats replaced with Ch or E ₂	109
23. Effects of ethanol treatments on AVP gene expression in the SON in ovariectomized female rats replaced with Ch or E ₂	111
24. Effects of EtOH treatment on CRH promoter activity in a neuronal cell line after E ₂ treatment	113
25. Summary of results described in Chapter 4	115
26. Effects of ethanol treatment on body weight during puberty and adulthood	130
27. Adult blood alcohol concentrations following EtOH treatment	132
28. Effects of pubertal binge EtOH pre-treatments on plasma CORT levels in EtOH exposed adult animals	135
29. Effects of pubertal binge EtOH pre-treatments on CRH gene expression in EtOH exposed adult animals	138

30. Effects of pubertal binge EtOH pre-treatments on AVP gene expression in the PVN of EtOH exposed adult rats	139
31. Effects of pubertal binge EtOH pre-treatments on AVP gene expression in the SON of EtOH exposed adult rats	141
32. Summary of results described in Chapter 5	144
33. Representative diagram depicting the brain area microdissected for the PVN	173

LIST OF ABBREVIATIONS

EtOH	alcohol
HPA axis	hypothalamo –pituitary-adrenal axis
PVN	paraventricular nucleus
SON	supraoptic nucleus
AVP	arginine vasopressin
CRH	corticotrophin releasing hormone
CORT	corticosterone
ACTH	adrenocorticotrophic hormone
ER β	estrogen receptor beta
E ₂	17 β estradiol
T	testosterone
DHT	dihydrotestosterone
MeA	medial amygdala
VTA	ventral tegmental area
nGRE	negative glucocorticoid response element
CRE	cAMP response element
GR	glucocorticoid receptor
CRH Δ GR1	CRH promoter containing deletion of GR binding site 1
CRH Δ GR2	CRH promoter containing deletion of GR binding site 2

CRH Δ GR3	CRH promoter containing deletion of GR binding site 3
CRH Δ GR1/2	CRH promoter containing double deletion of GR binding site 1 & 2
CRH Δ CRE	CRH promoter containing deletion of GR the CRE site

ABSTRACT

Binge alcohol (EtOH) exposure in adolescence is a fundamental health concern. In 2005, over 20% of teenagers between ages 15 and 17 reported binge drinking behavior within a one month period preceding the survey (Dept. of Health and Human Services: Substance Abuse and Mental Health Services Administration). Binge drinking is defined as consuming enough alcohol within a 2.0 h period to bring blood alcohol concentration above 0.08%. In the adolescent population, this type of alcohol exposure tends to be repeated. In adults, alcohol abuse has been correlated with increased incidence of mood disorders and these disorders are characterized by dysregulation of the hypothalamo-pituitary-adrenal (HPA) axis, a three tiered biological system that mediates physiological stress response. Corticotrophin releasing hormone (CRH) and arginine vasopressin (AVP) localized in the paraventricular nucleus (PVN) of the hypothalamus are the major neuropeptides involved in modulating HPA axis responses to stress. Corticosterone (CORT) in rodents, and cortisol in humans, is a major glucocorticoid hormone released into the circulation upon activation of the HPA axis. Puberty is a period during which extensive maturation occurs, yet our knowledge of the neurobiological consequences of binge EtOH exposure during this time period is severely limited. I sought to investigate the neuroendocrine consequences of EtOH exposure during pubertal maturation and tested the

hypothesis that EtOH exposure during puberty has long lasting detrimental consequences for a proper maturation of the HPA axis. My data revealed that repeated binge-pattern EtOH exposure resulted in a sex specific dysregulation of the HPA axis in pubertal rats. This was marked by an increase in the expression of CRH and AVP mRNA in the male, but not female, PVN. Notably, in both sexes, both single and repeated binge EtOH exposures resulted in increased circulating CORT levels and habituation effects. These results suggested that repeated binge-like EtOH exposure differentially dysregulated the HPA axis in males compared to females (Przybycien-Szymanska et al., *AJP Endocrin. and Metabol.*, 2010). My data further showed that the sex steroid hormone, 17 β -estradiol, is required for the maintenance of steady state levels of CRH and AVP mRNA in the PVN of pubertal female rats and for the habituation effects observed in CORT responses after repeated binge-pattern EtOH exposure. Most striking, these results showed that in males, binge-pattern EtOH exposure during puberty resulted in the dysregulation of adult HPA axis. This was evidenced by 1) increased adult basal levels of CRH mRNA in the PVN and lower basal circulating CORT levels, 2) differential patterns of CRH and AVP mRNA expression in the PVN after subsequent EtOH exposures in adulthood, 3) enhanced circulating CORT increase after single or repeated binge-like exposures in adulthood, 4) lack of habituation in CORT response after adult repeated binge pattern EtOH exposure (Przybycien-Szymanska et al., *PLoS One*, 2011).

In addition, I investigated the molecular mechanisms involved in the observed EtOH-induced increase in the CRH mRNA in the PVN. Increased gene expression correlates closely with increased gene promoter activity; therefore I tested whether EtOH affects CRH promoter activity and whether glucocorticoid negative feedback at the promoter was dysregulated by EtOH. My data showed that EtOH exerts a biphasic effects on the activity of the CRH promoter and these effects are blocked by glucocorticoid receptor (GR) antagonist and deletion of glucocorticoid response element site (a binding site for GR) on CRH promoter. These results indicated that EtOH dysregulates functioning of the HPA axis by interfering with normal negative glucocorticoid feedback mechanism exerted on CRH promoter. Moreover, I showed that 17 β -estradiol prevented the EtOH-induced increase in CRH promoter activity supporting a role of this hormone in the sexually dimorphic changes of CRH mRNA in the PVN after EtOH exposure.

In conclusion, my data showed that binge-pattern EtOH exposure during puberty has long lasting effects on the HPA axis. These effects are manifested by alterations in PVN expression of neuropeptides involved in modulating stress responses and glucocorticoid hormone signaling. These effects are caused by EtOH-induced dysregulation of glucocorticoid negative feedback normally exerted at the level of the gene promoter in the PVN and may lead to increased risk for mood disorders in adulthood.

CHAPTER ONE

INTRODUCTION

Literature review

Binge alcohol consumption in adolescents

Alcohol abuse during adolescence is a fundamental health concern in the United States. According to the U.S. Department of Health and Human Services, boys on average have their first drink before age 11 and girls tend to have their first drink before age 13. Alarming overall statistics show that by age 14, 41% of teenagers have consumed their first drink.

Underage drinkers do not chronically abuse alcohol, they typically adopt a “binge” pattern of alcohol consumption, defined by the National Institute on Alcohol Abuse and Alcoholism (NIAAA) as heavy, episodic drinking in which enough alcohol (on average 4 or 5 drinks in adult females and males, respectively) is consumed to bring the blood alcohol concentration above 0.08 % limit within that 2.0 h time period (White, Kraus et al. 2006). According to the Department of Health and Human Services survey performed in 2005, 2.0% of 12-13 year-old, 8.0% of 14-15 year-old, 19.7% of 16-17 year-old, and 51% of 18-20 year-old adolescents reported this pattern of drinking within a month preceding the survey. Overall, these statistics indicate that a significant

percentage of the young population consumes heavy doses of alcohol during adolescence.

Brain development during adolescence

The onset of adult reproductive functions, also known as puberty, is marked by many endocrinological, neurological and anatomical changes in both males and females. During this time period, changes in hormone levels accompany gonad maturation and acquisition of secondary sex characteristics. In addition to sexual maturation, the late pubertal period, also known as adolescence, is a period during which extensive brain maturation continues to occur. Even though it is relatively vague, very often adolescence is a term describing a time period of maturation between puberty and adulthood. This phase is marked by emotional, cognitive and personality development and is characterized by increased associations with groups of peers, increased risk taking behavior, lack of behavioral inhibition, and mood swings. These personality changes are a result of extensive brain maturation occurring during this time and characterized by changes in cortical gray matter (Lenroot and Giedd 2006), increased neurogenesis in some brain areas (Rankin, Partlow et al. 2003; Raymond, Kucherepa et al. 2006; Ahmed, Zehr et al. 2008), increased dendritic pruning in other brain regions (Woo, Pucak et al. 1997; Zehr, Todd et al. 2006), changes in corpus collosum thickness (Luders, Thompson et al.; Luders, Thompson et al. 2010) and increased synaptic connectivity (Cunningham, Bhattacharyya et al. 2002). Adolescents may be extremely vulnerable to harmful

effects of drugs of abuse, including alcohol because of this extensive brain maturation occurring during this stage of development.

Fetal brain development and some of the effects of in utero alcohol exposure

The embryonic stage of life is extremely vulnerable to any types of stressors because it is the time during which all critical systems in the fetus are being formed. Obviously, one of the organs that develop during this time period is the brain. Alcohol exposure during a critical developmental period, such as embryonic or pubertal development, may result in long lasting alteration of the systems that undergo development or maturation during these periods. Alcohol (EtOH) exposure during fetal development has been shown to cause neuronal dysfunction and cell death (Miki, Harris et al. 2003; Ramachandran, Watts et al. 2003; Akbar, Baick et al. 2006; Aloe 2006; Camarillo and Miranda 2008) and it has been well described that in utero alcohol exposure can result in development of a spectrum of disorders called Fetal Alcohol Spectrum Disorder (FASD) in the offspring. Among other characteristics, FASD is marked by a mild or, in some cases, severe mental retardation. This mental retardation is indicative of alcohol exposure induced compromise in brain development that could be a result of EtOH induced neuronal dysfunction. Some of the brain systems that are affected by fetal EtOH exposure are cortical and striatal dopaminergic systems (Druse, Tajuddin et al. 1990), cortical and brain stem serotonergic systems (Druse, Kuo et al. 1991; Tajuddin and Druse 1993; Kim, Gillespie et al. 1997; Tajuddin and Druse 1999), brain stem adrenergic systems (Choi, Lee et al. 2008) and the

hypothalamo-pituitary-adrenal (HPA) axis (Taylor, Branch et al. 1981; Taylor, Nelson et al. 1984; Tajuddin and Druse 1999; Hofmann, Ellis et al. 2007; Lee, Choi et al. 2008). For example, in utero EtOH exposure decreased serotonin levels and the density of its receptors in the brain stem and in the motor and somatosensory cortices (Druse, Kuo et al. 1991; Tajuddin and Druse 1993). EtOH exposure also decreased dopamine levels, dopamine uptake sites and the number of dopamine receptors in the striatum (Druse, Tajuddin et al. 1990). Abnormal formation of either of these systems, dopaminergic, serotonergic or adrenergic, increases the risk for developing substance dependence, mental retardation, or mood disturbances in the offspring.

Mood disturbances are the end result of the dysregulation of the homeostatic balance between different players of the HPA axis. Functioning of the HPA axis is severely compromised by fetal EtOH exposure. It has been shown that in utero EtOH exposure resulted in the hyperactivity of the HPA axis responses in the young and adult offspring (Ogilvie and Rivier 1997; Kim, Giberson et al. 1999). In post natal day (PND) 21 offspring, for example, this hypersensitivity was marked by an enhanced increase in foot shock induced elevation in plasma adrenocorticotrophic hormone (ACTH) levels and an increase in basal (non-stress) corticotrophin releasing hormone (CRH) messenger ribonucleic acid (mRNA) levels (Lee, Imaki et al. 1990; Ogilvie and Rivier 1997). Interestingly, the effects of in utero EtOH exposure were observed specifically if EtOH exposure occurred during the second week of gestation (Lee, Imaki et al. 1990). The second week of rat pregnancy coincides with the

development of the rat hypothalamic CRH system (Altman and Bayer 1986), therefore, EtOH exposure in utero may result in permanent dysregulation of the system. Notably, the hyper-sensitivity of the HPA axis after fetal EtOH exposure was maintained until adulthood. In multiple studies, it has been shown that in rats exposed to EtOH in utero, a stressor induced increase in ACTH release was enhanced in adulthood (Weinberg 1988; Kang, Cole et al. 2004; Lee, Choi et al. 2008). In addition, CRH hetero nuclear (hn) RNA was increased after stressor in adult rats pre-exposed to EtOH in utero as compared to control rats (Lee, Choi et al. 2008). Together, these data suggest that alcohol exposure during a critical developmental period, such as embryonic or pubertal development, may result in long lasting alteration of the systems that undergo development or maturation during these periods, however, long lasting effects of EtOH exposure during puberty have not been extensively investigated.

The hypothalamo-pituitary-adrenal (HPA) axis

The hypothalamo-pituitary adrenal (HPA) axis is a three part endocrine system responsible for coordinating stress responses. In a healthy system, upon stressful stimulus, parvocellular cells of the PVN (pPVN) located in the hypothalamus synthesize and secrete corticotrophin-releasing hormone (CRH) and arginine vasopressin (AVP). CRH and AVP then activate CRH 1 receptors (CRH-R1) and vasopressin 1B (V1B) receptors, respectively, in the anterior pituitary gland and act synergistically to stimulate the anterior pituitary gland to produce adrenocorticotrophic hormone (ACTH) (Aguilera, Harwood et al. 1983;

Rivier, Rivier et al. 1996; Papadimitriou and Priftis 2009) . CRH and AVP expressing neurons in the PVN that project to the median eminence and stimulate ACTH secretion from the anterior pituitary gland play a pivotal role in orchestrating central and endocrine signals reaching the brain during stressful events, therefore, proper functioning of these neurons is critical for maintaining homeostasis after stress. After CRH and AVP stimulation, corticotrope cells of the pituitary release ACTH into systemic circulation and then ACTH acts in endocrine fashion on the adrenal gland to produce and release glucocorticoids, cortisol in humans and corticosterone (CORT) in rodents (Papadimitriou and Priftis 2009) . Glucocorticoids can then exert negative feedback on both the hypothalamus and pituitary gland to decrease the neuropeptides and ACTH release, respectively, allowing for homeostatic state to be re-established (Erkut, Pool et al. 1998; Malkoski and Dorin 1999; Figueiredo, Bodie et al. 2003; Ostrander, Ulrich-Lai et al. 2006; Yamamori, Iwasaki et al. 2007; Papadimitriou and Priftis 2009; van der Laan, de Kloet et al. 2009).

Paraventricular nucleus of the hypothalamus (PVN). Outputs and Inputs.

The paraventricular nucleus of the hypothalamus (PVN) is a diverse group of cell bodies localized in the hypothalamus adjacent to the third ventricle. In the adult rat brain it is localized between 0.8 mm and 2.12 mm posterior to Bregma, 8.0 mm below the top of the brain (Smith, Gardiner et al. 2008) (Paxinos and Watson, Rat Brain Atlas, 5th edition). Among other neuropeptides and neurotransmitters, parvocellular cells of the PVN (pPVN) contain CRH and

arginine vasopressin (AVP) hormones and magnocellular cells of the PVN (mPVN) are known to produce AVP (Hou-Yu, Lamme et al. 1986; Ogilvie, Lee et al. 1998; Schulkin, Gold et al. 1998; Robertson 2001; Cole and Sawchenko 2002; Isgor, Shieh et al. 2003). Cells expressing CRH and AVP that are located in specific portions of the pPVN project to the median eminence where they secrete CRH and AVP into portal circulation by which these neuropeptides reach pituitary gland (Aguilera, Harwood et al. 1983; Rivier, Rivier et al. 1996; Hrabovszky, Deli et al. 2007). In addition to modulating stress reactivity, the PVN is involved in regulation of other critical body functions. For example, the PVN is known to send its glutamatergic projections to lateral hypothalamus (Hatton, Cobbett et al. 1985), medial preoptic area (Kocsis, Kiss et al. 2003) and supraoptic nucleus (SON) (Csaki, Kocsis et al. 2002), therefore influencing reproduction and water homeostasis. It also sends projection to medial amygdala (MeA) (Meurisse, Chaillou et al. 2009) and ventral tegmental area (VTA) (Rodaros, Caruana et al. 2007), therefore helps in coordinating emotional responses and appetitive behavior after stress.

The PVN does not function by itself. It receives a vast array of inputs from the central nervous system (CNS) therefore playing a pivotal role in coordinating homeostatic balance in the body. For example, PVN receives autonomic nervous system noradrenergic and adrenergic inputs from the brain stem, including such brain stem regions as ventral medulla, vagal complex and locus coeruleus (Sawchenko and Swanson 1982; Woulfe, Hryciyshyn et al. 1988; Sawchenko and

Bohn 1989), therefore coordinating functions of the autonomic nervous system and the HPA axis.

The serotonergic system also extensively influences functions of the HPA axis. For example, it has been shown that long term (14 day) treatment with selective serotonin reuptake inhibitor, Fluoxetine, reversed conditioned stress response procedure induced increase in anxiety-like behavior (Zhang, Raap et al. 2000) The interaction between the serotonin system and the HPA axis may be occurring at the level of the PVN. Serotonergic axons terminate on CRH containing neurons within pPVN. Notably, serotonergic innervation to the pPVN has been shown to be greater than to other diencephalic regions and the innervation to the pPVN was more prominent than to the mPVN (Liposits, Phelix et al. 1987). Serotonin inputs have a stimulatory effect on the HPA axis as systemic administration of the serotonin precursor (5-hydroxytryptophan, 5-HTP) and serotonin reuptake inhibitor increased CRH mRNA expression in the PVN, increased ACTH precursor, pro-opiomelanocortin (POMC) mRNA in the anterior pituitary gland and increased plasma ACTH levels as compared to control animals (Jorgensen, Knigge et al. 2002). Also, activation of serotonin receptor 1A and 2A localized in the PVN increased basal plasma CORT levels and increase c-Fos activity in the PVN (Mikkelsen, Hay-Schmidt et al. 2004).

PVN is highly regulated by gamma aminobutyric acid (GABA) and glutamate projections of the limbic structures. For example, MeA sends GABAergic projections that terminate on the GABA receptor containing GABA inter-neurons located near the PVN indirectly stimulating the PVN activity

(Herman, Mueller et al. 2004). Infralimbic cortex can inhibit PVN activity, whereas hippocampus and anterior cingulate/prelimbic cortex projections to the PVN can stimulate the activity of the HPA axis (Herman, Tasker et al. 2002; Herman, Ostrander et al. 2005). Together, these data indicate that functioning of the HPA axis can be affected by various CNS systems including autonomic nervous system, serotonergic system, and limbic system. The HPA axis can in turn influence other functions in the body including reproduction; water balance, and memory therefore normal functioning of the HPA axis is critical for the health of the individual.

Pituitary gland and its functions

The pituitary gland is a small endocrine organ protruding from the ventral side of the hypothalamus. It is connected to the hypothalamus via the median eminence from which the pituitary stalk originates. The pituitary gland plays a critical role in coordinating water balance, reproduction, energy metabolism, growth and stress responses, therefore it is called a “master endocrine gland”. The pituitary gland consists of two major lobes, anterior (adenohypophysis) and posterior (neurohypophysis) lobe. The posterior pituitary gland stores and releases AVP (also called. antidiuretic hormone or ADH) that is produced in the supraoptic nucleus (SON) and mPVN and oxytocin hormone produced in the mPVN and SON. The anterior pituitary gland, on the other hand, is under a tight regulation of parvocellular cells of the hypothalamus and releasing factors produced in these neurons. The releasing factors produced in various

hypothalamic nuclei include, thyroid releasing hormone (TRH) that stimulates production of thyroid stimulating hormone (TSH) from the pituitary gland, growth hormone releasing hormone (GHRH) stimulating production and release of growth hormone (GH), prolactin releasing hormone stimulating prolactin release from the gland, and CRH and AVP that stimulate the production and release of ACTH. In addition, anterior pituitary releases luteinizing hormone (LH) and follicle stimulating hormone (FSH) that are under a tight regulation of gonadotropin releasing hormone (GnRH) (Gibo, Hokama et al. 1993; Dasen and Rosenfeld 1999) tightly regulating reproductive functions of both males and females.

As mentioned previously, ACTH release from the anterior pituitary gland is under a tight regulation by CRH and AVP neuropeptides produced in the pPVN. CRH released from the pPVN acts on the anterior pituitary gland corticotropes via activating CRH 1 receptors (CRH R1) and stimulating ACTH production (Aguilera, Harwood et al. 1983; Makino, Schulkin et al. 1995; Rivier, Rivier et al. 1996; Green, Figueroa et al. 2000; Rivier, Grigoriadis et al. 2003). AVP, synergistically with CRH, stimulates the production of ACTH by acting at the pituitary gland corticotropes expressing AVP 1b receptors (AVP 1b) (Ostrowski, Lolait et al. 1992; Lolait, O'Carroll et al. 1995; Aguilera and Rabadan-Diehl 2000). Proper functioning of these hypothalamic neurons is critical for the normal functioning of the anterior pituitary gland corticotropes as they influence glucocorticoid release from the adrenal cortex and coordinate stress responses.

Adrenals and their functions

Adrenal glands are the two separate endocrine glands. Each adrenal gland is located on top of each kidney. Each gland contains two distinct divisions, adrenal cortex, and medulla, both responsible for producing different types of hormones. The core of the adrenal gland, medulla, surrounded by the cortex, contains chromaffin cells producing catecholamines, adrenaline (also called epinephrine) and noradrenalin (also called norepinephrine). Epinephrine and norepinephrine are major players in the “fight-or-flight” responses of the autonomic nervous system during extreme stress. The major inputs to the medulla are sympathetic nervous system inputs originating from the thoracic spinal cord (Bacon and Smith 1988; Cao and Morrison 2001). Upon release, epinephrine and norepinephrine act on the heart, gastrointestinal tract and the brain to prepare the body for immediate response to stress, “fight or flight” response.

The adrenal cortex, on the other hand, is devoted to slower endocrine responses exerted by production of steroid hormones such as major stress steroid hormones glucocorticoids (cortisol in primates and corticosterone (CORT) in rodents) and aldosterone. In primates, adrenal cortex is also a source of androgens such as testosterone (T) and dehydroepiandrosterone (DHEA). The adrenal cortex is subdivided into three zones, *zona glomerulosa*, *zona fasciculata* and *zona reticularis*, each responsible for production of different hormones (Kater, Biglieri et al. 1982; Nishikawa and Strott 1984; Kater, Irony et al. 1990; Rosol, Yarrington et al. 2001; Rainey, Carr et al. 2002; Young, Murphy et al.

2003). The outer-most layer, *zona glomerulosa*, contains cells that produce aldosterone which is responsible for maintaining blood pressure (Kater, Biglieri et al. 1982). The inner layer, *zona fasciculata*, contains cells that are responsible for producing glucocorticoids, in response to the ACTH stimulation during stress (Nishikawa and Strott 1984; Kater, Irony et al. 1990). Inner-most layer of the cortex, *zona reticularis*, produces androgens, such as DHEA (Rainey, Carr et al. 2002).

Glucocorticoids released from the adrenal glands act on variety of organs in the body in order to help to maintain homeostatic balance during and after stress. In the brain, glucocorticoids act on different brain regions, including amygdala, hippocampus, suprachiasmatic nucleus (SCN) and the PVN (Clark and Kemppainen 1994; Roy, Mittal et al. 2002; Sage, Maurel et al. 2002; Liu, Unmehopa et al. 2006; Morsink, Steenbergen et al. 2006; Little, Croft et al. 2008). By modulating functions of these brain regions, glucocorticoids can affect emotion, memory, circadian rhythms, and their own release, therefore, chronic or extremely high elevation of these hormones may have detrimental consequences for the homeostatic balance in the body.

Glucocorticoid mediated negative feedback in the PVN

Glucocorticoid hormones released from the adrenals exert negative feedback at the level of the PVN and pituitary gland in order to bring their own release from the adrenals back to basal levels and return the HPA axis to its homeostatic state. They do that by decreasing the production and release of the

CRH and AVP from the PVN (Makino, Schulkin et al. 1995; Makino, Smith et al. 1995; Erkut, Pool et al. 1998; Malkoski and Dorin 1999) and ACTH release from the anterior pituitary gland (Clark and Kemppainen 1994). This negative feedback allows for a homeostatic state to be maintained after stress and any dysregulation of this feedback may result in developing mood disorders.

In the PVN, glucocorticoids directly affect the transcriptional activity of the CRH gene. Glucocorticoids activate glucocorticoid receptors (GR) which belong to a classical steroid receptor superfamily (ligand activated transcription factors). Upon activation by glucocorticoid, GR undergo dimerization, translocate to the nucleus and directly affect gene transcription (Goujon, Laye et al. 1997; Schulkin, Gold et al. 1998; Sapolsky, Romero et al. 2000; Morsink, Steenbergen et al. 2006). In the PVN, glucocorticoids acting through GR are known to decrease CRH gene transcription through signaling at the negative glucocorticoid response element (nGRE) located between -249 and -278 nucleotides upstream from the transcription initiation site of the CRH promoter and thorough interactions with cAMP response element (CRE) site of the CRH promoter located -224 upstream from the transcription initiation site. The CRE site binding of phosphorylated cAMP response element binding protein (pCREB) is required for an increase in CRH promoter activity and gene transcription (Van, Spengler et al. 1990; Malkoski and Dorin 1999; King, Smith et al. 2002; Yamamori, Iwasaki et al. 2007; Liu, Kamitakahara et al. 2008; van der Laan, de Kloet et al. 2009). Overall, glucocorticoids acting via GRs decrease CRH promoter activity in the PVN

therefore, they decrease transcriptional activity of the promoter and decrease CRH gene expression keeping the HPA axis in homeostatic state.

Role of arginine vasopressin (AVP) in the regulation of the HPA axis

In addition to CRH, arginine vasopressin (AVP) is another neuropeptide critical for mediating stress and anxiety responses. First discovered as antidiuretic hormone (ADH), AVP is synthesized in the supraoptic nucleus (SON), PVN, bed nucleus of stria terminalis (BSTN), amygdala and suprachiasmatic nucleus (SCN). Neurons that synthesize AVP in the pPVN project to the median eminence and facilitate the synergistic actions of AVP and CRH following stressful stimuli through enhancing ACTH and glucocorticoid release (Aguilera, Harwood et al. 1983; Ogilvie, Lee et al. 1997; Ogilvie and Rivier 1997; Scott and Dinan 1998; Papadimitriou and Priftis 2009). The role of AVP in regulation of the HPA axis is substantiated by the following data 1) chronic social stress changes the expression of AVP mRNA in the amygdala of adult rats (Albeck, McKittrick et al. 1997); 2) rats bred for high anxiety traits exhibit high levels of AVP expression in the PVN and higher level of vasopressin release compared to rats bred for low anxiety traits (Wigger, Sanchez et al. 2004); 3) mice lacking the vasopressin 1a (V1a) receptor exhibit reduced anxiety responses (Bielsky, Hu et al. 2004). In addition to stress regulation of the AVP expression, it has been shown that the transcriptional activity in hypothalamic neurons expressing AVP can be stimulated by acute alcohol (EtOH) administration demonstrated by increased amount of AVP hetero nuclear ribonucleic acid (hnRNA) in this brain region

(Ogilvie, Lee et al. 1997). Together these studies indicate that, in addition to corticotrophin releasing hormone (CRH), AVP is an important modulator of normal HPA axis function and that these function can be disrupted by EtOH exposure.

Pubertal maturation of the HPA axis

The HPA axis is one of the systems that undergo extensive plasticity during pubertal development (Romeo, Lee et al. 2004; Romeo, Bellani et al. 2006; Romeo and McEwen 2006; McCormick and Mathews 2007; Evuarherhe, Leggett et al. 2009; Evuarherhe, Leggett et al. 2009; Laroche, Gasbarro et al. 2009). Corticosterone (CORT) and CRH and AVP levels, are markedly different in response to both acute and chronic stressors in pre-pubertal (juvenile) and pubertal animals as compared with adult animals (Jankord, Solomon et al.; Romeo, Lee et al. 2004; Romeo, Bellani et al. 2006; Romeo and McEwen 2006; Laroche, 2009 #190; McCormick and Mathews 2007; Evuarherhe, Leggett et al. 2009; Evuarherhe, Leggett et al. 2009). Most striking is the observation that CORT and ACTH levels take much longer to return to baseline in juvenile compared to adult animals when subjected to a variety of stressful stimuli (Vazquez and Akil 1993; Romeo, Bellani et al. 2006). Further, juveniles have higher overall stress reactivity (Romeo, Bellani et al. 2006) and chronic stress during puberty has been shown to result in an exaggerated stress-induced CORT response in adulthood (Jankord, Solomon et al.; Isgor, Cecchi et al. 2003). In addition, even a very mild form of stress, such as shipping, during puberty

contributes to reduced sexual behaviors in adulthood as pubertal male and female mice shipped during their 6th week of age (puberty) exhibited suppressed sexual behaviors and lower plasma CORT levels at 12 weeks of age (adulthood) as compared to mice shipped during 12th week of age (Laroche, Gasbarro et al. 2009).

Changing gonadal steroid hormone levels differentially regulate the HPA axis during puberty vs. adulthood. It has been shown, for example, that ovariectomized pre-pubertal female rats (PND 28) replaced with estradiol (E₂) have suppressed stress responses (as measured by lower plasma CORT levels) after 30 min restraint stress compared with ovariectomized adult female rats replaced with E₂ and subjected to the same stressor (Evarherhe, Leggett et al. 2009). In males gonadectomized before puberty (PND 28), testosterone (T) treatment did not change adult circulating CORT levels but T decreased plasma CORT levels in animals that were gonadectomized in adulthood (11 week of age). Also, following 10 min noise stress in these same castrated during puberty males, testosterone (T) did not change the responsiveness of the HPA axis but T suppressed stress response in animals that were gonadectomized in adulthood (as measured by changes in CORT levels after stress) (Evarherhe, Leggett et al. 2009). Further, Viau et al. have shown that 60 day old females had highest basal and stress induced plasma ACTH and CORT levels when compared to 30 day old females, 60 day old and 30 day old males. 60 day old males, on the other hand, had the lowest basal and stress induced plasma ACTH and CORT levels when compared to 30 day old males, 60 day old and 30 day old females

indicating that changes in the responsiveness of the HPA axis that occur over pubertal maturation are correlated with changing sex steroid hormone levels (Viau, Bingham et al. 2005). Together these data indicate that during pubertal maturation, the HPA axis undergoes extensive organization and is vulnerable to any types of stressors. Stress and EtOH exposure during puberty may have long lasting behavioral consequences in adulthood resulting from long lasting alterations of the HPA axis.

Dysregulation of the HPA axis and mood disorders

Dysregulation of the normal glucocorticoid negative feedback and functioning of the HPA axis is a hallmark of different types of mood disorders, including but not limited to post-traumatic stress disorder (PTSD), depression and anxiety (Ikin, Creamer et al.; Pervanidou and Chrousos; Wood, Walker et al.; Smith, Davidson et al. 1989; Scott and Dinan 1998; Newport, Heim et al. 2003; Steimer, Python et al. 2007). For example, in depressed patients, intravenous infusion of CRH resulted in blunted ACTH release but normal cortisol release (Holsboer, Lauer et al. 1995; Arborelius, Owens et al. 1999). Patients with PTSD tend to have elevated cerebrospinal fluid CRH levels and blunted ACTH responses to CRH challenge as compared to healthy individuals (Smith, Davidson et al. 1989; Arborelius, Owens et al. 1999). These data indicate dysregulation of the CRH-ACTH signaling in mood disorders. Various other human and animal studies indicated involvement of both the CRH and AVP systems in different types of mood disorders and individual differences in the

susceptibility towards developing these types of disorders (Wood, Walker et al.; Jensen, Keller et al. 1997; Keck, Welt et al. 2003; Yamamoto, Morinobu et al. 2009); however, other systems influencing functioning of the HPA axis also play a role in developing mood disorders

Serotonergic and noradrenergic systems send their inputs to the PVN and have been implicated in major depressive and anxiety disorders (Eison 1990; Blier 2001). For example, enhanced serotonin transporter binding protein levels in the thalamus, insula and striatum were observed in patients with major depressive disorder or during the depressive stage of bipolar disorder (Cannon, Ichise et al. 2007). Serotonin 1A receptor function in patients with depression is reduced and this may be linked with reduction in the receptor binding potential in the cortex and raphe nucleus (Drevets, Thase et al. 2007). Selective serotonin reuptake inhibitors (SSRI) have been used in treatment of depression and generalized anxiety disorders as abnormality in serotonin receptor 1A, 1C and 2 functions have been implicated in these types of disorders (Baldwin and Rudge 1995; Gorman and Kent 1999). Lastly, serotonin neurons are known to inhibit norepinephrine neurons, therefore SSRI can affect the noradrenergic system as well (Blier 2001) and both of these systems affect functioning of the HPA axis. These data show that other neurotransmitter systems that converge on the HPA axis may be involved in mood disorders, however, at the end, mood disorders are characterized by dysregulation of the proper negative feedback of the HPA axis.

Sex differences in the HPA axis reactivity to stressors

There are gender differences in susceptibility of men and women to mood disorders with females being at a higher risk for these types of disorders (Zilberman, Tavares et al. 2003; Becker, Monteggia et al. 2007). Multiple studies have shown that in adult animals there are sex differences in the responsiveness of the HPA axis to stress and alcohol administration. For example, there are sex differences in 30 min restraint stress induced CORT release with young (PND 20) females having lower plasma CORT levels and adult females (PND 80) having higher plasma CORT levels compared to males (Sencar-Cupovic and Milkovic 1976; Evuarherhe, Leggett et al. 2009). Also, after acute EtOH injection (3 g/kg) adult females had higher plasma ACTH and CORT increase compared to adult males (Rivier 1993; Ogilvie and Rivier 1996; Ogilvie and Rivier 1997). These data clearly show that there are sex differences in the responsiveness of the HPA axis to stressors at the levels of the ACTH and CORT.

There are also sex differences in adult basal CRH and AVP mRNA levels in the PVN as well as CRH and AVP mRNA levels in adult males and females after stress and EtOH exposure. For example, adult intact and adrenalectomized (PND 80) females have lower basal CRH and AVP mRNA in the PVN compared to age matched males (Patchev, Hayashi et al. 1999). In females, contrary to males, there are no changes in the expression of AVP mRNA 3.0 h after acute EtOH injection either in the pPVN or magnocellular (m) PVN (Ogilvie and Rivier 1997). Contrary to female data, in adult males, acute EtOH administration increases the expression of AVP mRNA in the pPVN after 3.0 h but fails to

change the expression of CRH heteronuclear (hn) RNA after 20 min in the same region (Rivier and Lee 1996). Together, these data clearly show that there are sex differences in the responsiveness of the HPA axis to stressors and to EtOH exposure at the level of the PVN, but the mechanisms involved in these differences are not well known.

Steroid hormones have been shown to modulate the stress responsiveness of the HPA axis in males and in females. For example, in females, there was a greater plasma CORT increase after stress and alcohol administration as compared to males (Sencar-Cupovic and Milkovic 1976; Rivier 1993; Ogilvie and Rivier 1997; Evuarherhe, Leggett et al. 2009; Weiser and Handa 2009). T is known to play inhibitory role on stress induced functions of the HPA axis marked by decreased ACTH and CORT increase when compared to females and increased basal plasma CORT levels in gonadectomized males as compared to intact males (Ogilvie and Rivier 1997; Viau, Chu et al. 1999; Williamson and Viau 2008; Evuarherhe, Leggett et al. 2009).

T and its metabolites, such as 3β -diol and dihydrotestosterone (DHT), also differently modulate the HPA axis activity at the level of hypothalamus (De Vries, Wang et al. 1994; Viau and Meaney 1996; Viau, Chu et al. 1999; Viau, Lee et al. 2003; Scordalakes and Rissman 2004; Lund, Hinds et al. 2006; Pak, Chung et al. 2007; Williamson and Viau 2008; Handa, Weiser et al. 2009; Pak, Chung et al. 2009). These effects can be mediated through estrogen receptor beta (ER β), main ER found in the PVN (Isgor, Cecchi et al. 2003; Miller, Suzuki et al. 2004; Lund, Rovis et al. 2005; Suzuki and Handa 2005; Pak, Chung et al. 2007; Handa,

Weiser et al. 2009) and through androgen receptor (AR) present in the PVN and in other hypothalamic regions modulating PVN activity (Viau and Meaney 1996; Lund, Hinds et al. 2006). For example, in bed nucleus of stria terminalis (BST) of gonadectomized adult rats, DHT and E₂ increase AVP mRNA as compared to gonadectomized rats not replaced with hormones. In juvenile rats, on the other hand, E₂ and 3 β -diol, but not DHT, increase AVP mRNA expression in BST but only E₂ increased AVP mRNA expression in medial amygdala (MeA) (Pak, Chung et al. 2009). In addition, 3 β -diol is known to activate the AVP promoter activity in a neuronal cell line (Pak, Chung et al. 2007; Pak, Chung et al. 2009). Together these data indicate that sex steroid hormones modulate the HPA axis activity at different levels of the HPA axis functioning.

Chronic stress and hypo-activity of the HPA axis

Chronic stress induces habituation of the HPA axis. Several studies have shown that chronic stressor induced a lesser activation of the HPA axis as compared to acute stressor induced activation of the axis (Figueiredo, Bodie et al. 2003; Girotti, Pace et al. 2006; Ostrander, Ulrich-Lai et al. 2006; Ostrander, Ulrich-Lai et al. 2009). For example, acute cat exposure for 1.0 h (acute stress) resulted in a significant rise in plasma ACTH and CORT levels just after the cessation of the stressor as compared to no-stress control rats, however, daily 1.0 h exposures for 7 or 14 days (chronic homotypic stress) resulted in ACTH and CORT levels that were not significantly different when compared to control, not stressed, animals. CRH mRNA in the PVN, on the other hand, was

significantly elevated after both acute and chronic stressors (Figueiredo, Bodie et al. 2003). In addition, chronic variable stress (twice daily exposure to various stressors (1.0 h restraint, 1.0 h restraint in cold temp, 1.0 h shaker stress, 20 min warm water forced swim, or 5.0 min cold water stress) plus occasional overnight stressor (overnight social isolation or overnight social crowding stress) for seven consecutive days) resulted in lower plasma ACTH responses to the new environment challenge 4.0 and 7.0 days after chronic variable stress paradigm. The same was true when plasma CORT levels were measured, however, the CRH mRNA in the PVN was elevated if novel environments challenge was administered 16.0 h after cessation of chronic variable stress and was not different after 4.0 or 7.0 days (Ostrander, Ulrich-Lai et al. 2006). These data suggest that chronic stress; either homo- or heterotypic, results in a habituation of the HPA axis responsiveness after cessation of the stressor or after exposure to a novel stressor. The mismatch between CRH mRNA levels and plasma hormone measurements further indicate that chronic stress in adulthood dysregulates normal functioning of the HPA axis and this may be linked to mood disturbances.

Alcohol abuse and relationship to mood disorders

Alcohol exposure is closely linked with a dysregulation of adult and adolescent stress system. For example, alcohol abuse in adulthood is correlated with a higher incidence of clinically diagnosed anxiety disorders and in adolescent and adult populations, alcohol consumption is correlated with

increased suicide risk (Pompili, Serafini et al.; Zilberman, Tavares et al. 2003; Makhija and Sher 2007). Notably, women tend to be more sensitive to the effects of alcohol and have a higher incidence of clinically diagnosed anxiety disorders compared to men (Zilberman, Tavares et al. 2003; Becker, Monteggia et al. 2007). In corroboration with human studies, it has been shown in experimental animals that EtOH exposure changes animal's anxiety responses as well. In adolescent rats, for example, EtOH exposure increased anxiety-like behaviors without affecting performance in the retention based passive avoidance or novel object exploration tasks, performance which is indicative of memory retention abilities (Popovic, Caballero-Bleda et al. 2004). The link between increased risk of mood disorders in human population and increased anxiety-like behaviors in animals is substantiated by data showing EtOH induced alterations in neuropeptides involved in modulating HPA axis, CRH and AVP in the paraventricular nucleus of the hypothalamus (PVN), main brain region involved in coordinating stress responses in mammals (Allen, Rivier et al.; Rivier, Bruhn et al. 1984; Ogilvie and Rivier 1996; Rivier and Lee 1996; Ogilvie, Lee et al. 1997; Ogilvie, Lee et al. 1997; Ogilvie and Rivier 1997; Ogilvie, Lee et al. 1998; Ogilvie, Lee et al. 1998; Li, Kang et al. 2005). Together these data indicate that EtOH exposure dysregulates proper functions of the HPA axis which dysregulation is linked with developing mood disorders.

Alcohol exposure during puberty and its long lasting effects

During puberty, EtOH exposure induces brain damage due to inflammation and has long lasting effects on a variety of CNS structures, including the mesolimbic dopaminergic and glutaminergic system (Pascual, Boix et al. 2009), hippocampus, and cerebellum (Pascual, Blanco et al. 2007). Such changes in the CNS are often manifested by altered adult behaviour patterns (Maldonado-Devincci, Badanich et al.; Slawecki, Thorsell et al. 2004; Pascual, Blanco et al. 2007; Pascual, Boix et al. 2009). For example, Pascual et al. showed that 2 weeks of intermittent EtOH administration (single ip injection of 3.0 g/kg EtOH for two consecutive days, followed by 2 day rest, then followed again by 2 days of EtOH injections) caused an increase in voluntary EtOH consumption in adult rats (Pascual, Boix et al. 2009). In a different study, they also showed that this intermittent pattern of EtOH administration induced long lasting deficits in learning ability, as discerned by a decreased number of correct choices in conditional discrimination learning task, and a reduced ability to adapt to a challenging environment in adulthood in a narrow beam task (Pascual, Blanco et al. 2007). These data indicate that the developing adolescent brain is extremely vulnerable to EtOH-induced toxicity and that effects of EtOH exposure during puberty can be observed in adulthood.

Summary

Binge alcohol abuse during adolescence is a fundamental health concern in the United States. Adolescence is a period during which extensive brain maturation continues to occur, therefore, this high dose EtOH exposure during this period can have detrimental effects on proper brain maturation. It has been shown that EtOH exposure during puberty can cause brain damage and that EtOH exposure during this phase of life has long lasting effects on a variety of CNS structures. These effects can be manifested by changes in adult behavioural responses.

One of the systems that undergo extensive plasticity during pubertal development is the HPA axis responsible for coordinating stress responses. Dysregulation of the proper responses of this system, i.e. abnormal brain expression of neuropeptides involved in modulating stress responses, CRH and AVP and disrupted glucocorticoid signaling at the level of the PVN, results in development of different types of mood disorders including anxiety, depression and PTSD. In adulthood, alcohol abuse has been shown to be correlated with a higher incidence of clinically diagnosed anxiety disorders and increased suicide risk with women tending to be more sensitive to the effects of alcohol and have higher incidence of clinically diagnosed anxiety disorders compared to men. Even though the HPA axis changes during adolescence, consequences of binge pattern of EtOH exposure during this time period on the development of the HPA axis have not been investigated and have to be addressed in further research.

Next Step in Alcohol Research: Consequences of adolescent binge alcohol exposure and mechanisms involved.

It is well established that the HPA axis undergoes extensive maturation during adolescent period (Romeo and McEwen 2006; McCormick and Mathews 2007; Evuarherhe, Leggett et al. 2009; Evuarherhe, Leggett et al. 2009). Previous reports have indicated that adult CRH and AVP expressing neurons in the PVN are modulated by EtOH exposure (Rivier, Bruhn et al. 1984; Ogilvie and Rivier 1996; Rivier and Lee 1996; Ogilvie, Lee et al. 1997; Ogilvie, Lee et al. 1997; Ogilvie and Rivier 1997; Ogilvie, Lee et al. 1998; Ogilvie, Lee et al. 1998; Li, Kang et al. 2005) and that there are sex differences in the responsiveness of adult HPA axis to stress and EtOH exposure (Sencar-Cupovic and Milkovic 1976; Rivier 1993; Ogilvie and Rivier 1996; Ogilvie and Rivier 1997; Patchev, Hayashi et al. 1999). In addition, it has been shown that pubertal binge like EtOH exposure increased anxiety-like behaviors during this critical developmental time period (Popovic, Caballero-Bleda et al. 2004). The long lasting consequences of binge EtOH exposure on the development of the HPA axis have not been investigated. The overall goal of these studies was to extend previous findings performed in pubertal and adult animal models of EtOH exposure by elucidating 1) short term effects of binge EtOH exposure during peri-pubertal period on the expression of CRH and AVP mRNA in the PVN and plasma CORT levels, 2) molecular mechanisms involved in EtOH effects and observed sex differences in the responsiveness of the HPA axis to EtOH exposure and 3) long lasting neuroendocrine consequences of binge EtOH exposure during this critical time

period on functioning of adult HPA axis as it has been shown that alcohol consumption during adolescence is a fundamental health concern and can have detrimental effects on proper HPA axis maturation.

Hypothesis and Aims

One way to establish long lasting effects of binge EtOH exposure on functioning of adult HPA axis is to measure CRH and AVP mRNA expression in the PVN and circulating CORT levels in adult animals pre-exposed to binge EtOH paradigm during peri-pubertal development but before we can establish these long lasting effects of pubertal binge EtOH exposure, we have to verify if binge EtOH exposure during peri-puberty alters CRH and AVP mRNA expression in the PVN and what are possible mechanisms for these changes. In addition, based on the previous adult data, I also have to investigate whether there are sex differences in the responsiveness of adolescent HPA axis to EtOH exposure and if yes, what are possible mechanisms for these differences. If I see changes in pubertal HPA axis functioning after binge EtOH exposure, I can establish if these changes result in long lasting perturbations of the HPA axis. Based on previous data, I hypothesized that *binge alcohol exposure during peri-pubertal development results in a long lasting dysregulation of adult HPA axis caused by permanent changes in the pubertal expression of the CRH and AVP mRNA expression in the PVN which results from EtOH induced dysregulation of the glucocorticoid negative feedback at the level of the hypothalamus* (Fig. 1).

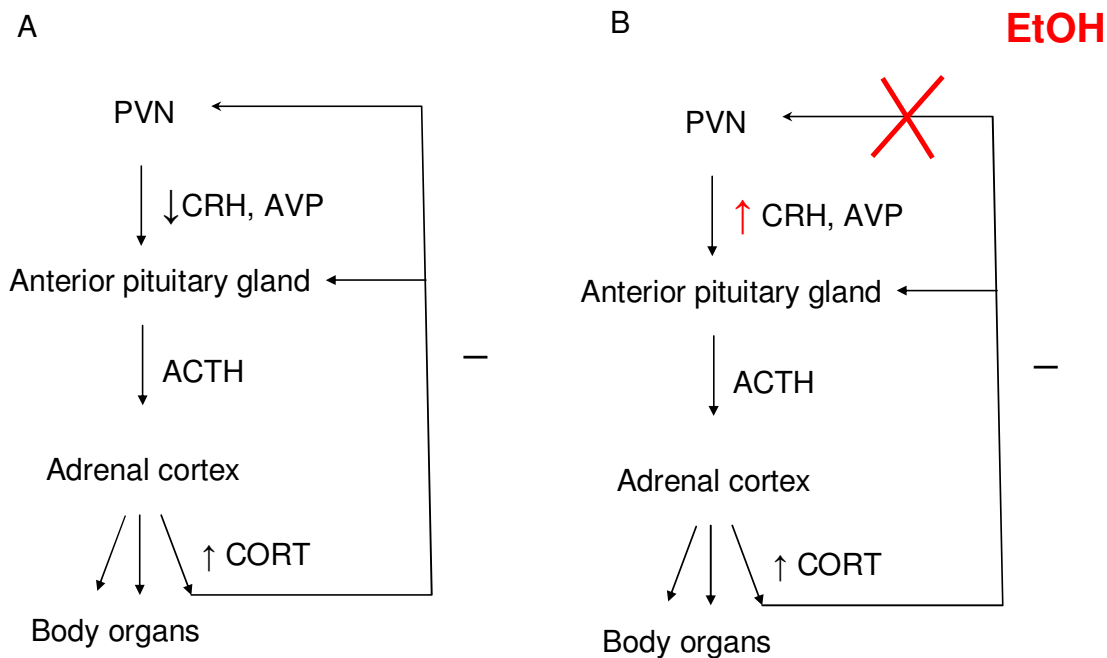

Fig 1. Schematic representation of the proposed hypothesis. A. Normal functioning of the HPA axis. Increased glucocorticoid (CORT) level exerts negative feedback to decrease production and release of CRH and AVP from the hypothalamus. I hypothesize that binge alcohol exposure during pubertal development results in a long lasting dysregulation of adult HPA axis caused by permanent changes in the pubertal expression of the CRH and AVP mRNA in the PVN which results from EtOH induced dysregulation of the glucocorticoid negative feedback at the level of the hypothalamus (B).

The following Specific Aims were established in order to test this hypothesis:

Aim 1. Short term effects of binge EtOH exposure during peri-puberty.

It is well established that adult EtOH exposure alters gene expression of CRH and AVP in the PVN and that there are sex differences in the responsiveness of adult HPA axis to EtOH exposures (Rivier 1993; Ogilvie and Rivier 1996; Rivier and Lee 1996; Ogilvie, Lee et al. 1997; Ogilvie and Rivier 1997; Li, Kang et al. 2005). However, the effects of EtOH exposure during puberty on the central regulators of the HPA axis, CRH and AVP remain unknown. In this aim I answered following questions:

1) *Does binge EtOH exposure during peri-puberty change the PVN expression of stress regulated neuropeptides, CRH and AVP during this time period?*

2) *Are there sex differences in the responsiveness of peri-pubertal HPA axis to binge EtOH exposure?*

3) *If there are sex differences in the responsiveness of pubertal HPA axis to binge EtOH exposure, is 17 β -estradiol responsible for these sex differences?*

In order to answer these questions, peri-pubertal male and female rats were subjected to binge EtOH exposure paradigm 1.0 h after the last EtOH treatment, animals were sacrificed and blood and brains were collected. Plasma was isolated from the blood and used for measurements of blood EtOH concentrations (BAC) and hormone levels. Brains were rapidly frozen, specific

nuclei were microdissected and RNA was isolated. Quantitative real time reverse transcription-polymerase chain reaction (qRT-PCR) was used to measure changes in the mRNA expression in these brain nuclei. See Chapter 2 Results section and Chapter 7, General Methods section, for detailed description of experimental design and specific methods used for each specific experiment performed in this aim.

In summary, my data showed that repeated binge, but not acute binge, EtOH exposure in peri-puberty increased the PVN expression of CRH and AVP mRNA but this effect was observed only in males. EtOH exposure had no effects on the CRH and AVP mRNA expression in peri-pubertal females indicating clear sex difference in the responsiveness of pubertal HPA axis to binge EtOH exposure. Further, the data showed that 17β -estradiol (E_2) is partially responsible for observed sex differences but it is not the only factor involved.

Aim 2. Molecular mechanism involved in EtOH effects in the PVN and observed sex differences in the CRH expression after EtOH exposure.

Binge EtOH exposure increased CRH mRNA levels in the PVN and plasma CORT levels in peri-pubertal male rats (Przybycien-Szymanska, Rao et al. 2009) which is indicative of disrupted negative feedback that should be exerted by glucocorticoids at the level of the PVN in an undisturbed situation. In addition, in studies with ovariectomized females, I have shown that E_2 is partially responsible for observed sex differences in the responsiveness of the HPA axis

to EtOH exposures (Chapter 4); however, the molecular mechanisms behind these EtOH effects remain unknown. In this aim I answered following questions:

- 1) *Does EtOH treatment directly regulate the activity of the CRH promoter?*
- 2) *Does EtOH interfere with the glucocorticoid negative feedback that should be normally exerted at the CRH promoter?*
- 3) *What specific sites on the CRH promoter are involved in EtOH effects?*
- 4) *Does 17 β -estradiol (E₂) treatment affect EtOH induced changes in the activity of the CRH promoter?*

In order to answer these questions, cells derived from rat PVN (IVB cell line) were seeded and then transiently transfected with the wild type (WT) or mutated CRH promoter. 24.0 h after transient transfections, cells were treated with EtOH and after appropriate treatment time, dual luciferase reporter assay was performed in order to measure changes in the promoter-luciferase activity due to EtOH treatments. In addition, cells were treated with the same EtOH treatment paradigms in the presence of 10 nM E₂ and this was done in order to investigate the role of E₂ in sex specific effects of EtOH. See Chapters 3 and 4 Results section and Chapter 7, General Methods section, for detailed description of experimental design and specific methods used for each specific experiment performed in this aim.

In summary, data presented in Chapter 3 showed that 12.5 and 100 mM EtOH treatment exerts biphasic effects on the activity of the CRH promoter with an initial decrease in the activity of the promoter at 0.5 h time point followed by an increase in the activity at 2.0 h. Interestingly, at the 2.0 h time point even dose as low as 12.5 mM induced an increase in CRH promoter activity. This effect was blocked when cells were treated with EtOH in the presence of glucocorticoid receptor (GR) antagonist and when portions of the negative glucocorticoid response element (nGRE) site and the cAMP response element (CRE) site of the CRH promoter were deleted. In addition, data presented in Chapter 4 showed that in the presence of E₂, EtOH did not change CRH promoter activity supporting the role of E₂ in mediating sexually dimorphic effects of EtOH. Together, these data indicated that EtOH exerts direct effects on the activity of the CRH promoter resulting in changes in CRH gene expression by interfering with GR signaling at the level of the CRH promoter and that EtOH interaction with E₂ is partially responsible for observed sex differences.

Aim 3. Long lasting consequences of binge EtOH exposure during peri-pubertal development on functioning of adult HPA axis.

Previous data showed that pubertal EtOH exposure has long lasting behavioral consequences marked by increased EtOH preference and impaired learning in adult animals (Pascual, Blanco et al. 2007; Pascual, Boix et al. 2009). I have shown that binge EtOH exposure in peri-pubertal male rats increased PVN expression of CRH and AVP mRNA (Przybycien-Szymanska, Rao et al. 2009)

and that EtOH induced dysregulation of normal negative GR feedback at the level of the CRH promoter in the PVN cells is involved in these effects (Chapter 3). One main question that remains unanswered is whether these changes observed in peri-puberty are long lasting and result in dysregulation of functioning of adult HPA axis. In this aim, I answered the following questions:

1) Do changes observed during peri-puberty in the CRH and AVP mRNA persists into adulthood?

2) Are adult animals pre-exposed to binge EtOH during peri-puberty more sensitive to subsequent single EtOH exposure in adulthood?

3) Do adult animals pre-exposed to binge EtOH during peri-puberty habituate to subsequent binge EtOH exposure in adulthood.

In order to answer these questions, peri-pubertal male rats were treated either with saline or binge EtOH exposure and then allowed to reach adulthood without any disturbances. In adulthood, these same animals were further subdivided into saline, acute EtOH and binge EtOH treatment groups (see Table 3 and General Methods of Chapter 7 for a detailed description) On the last day of adult treatments, 1.0 h after the last EtOH exposure, animals were sacrificed and blood and brains were collected. Plasma was isolated and used for BAC and hormone measurements. Brains were rapidly frozen, sectioned on a freezing microtome and PVN and SON were microdissected. Total mRNA was isolated and then qRT-PCR was performed to measure changes in the gene expression in these nuclei in all treatment groups. See Chapter 5 Results section

and Chapter 7, General Methods section, for detailed description of experimental design and specific methods used for each specific experiment performed in this aim.

Data collected in these experiments showed that binge EtOH exposure during peri-puberty resulted in long lasting changes in functioning of adult HPA axis marked by increased basal expression of CRH mRNA in the PVN and lower basal plasma CORT levels as compared to adult EtOH naïve rats. In addition, these data showed that binge EtOH exposure during peri-puberty increased sensitivity of adults to subsequent EtOH exposures as marked by enhanced increase in plasma CORT levels after adult acute and binge EtOH exposure as compared to adult EtOH naïve rats. In addition, at the level of the PVN, binge EtOH exposure during peri-puberty caused a different pattern of the CRH and AVP mRNA responses as compared to these animals that did not binge during puberty. Together, these data clearly show that binge EtOH exposure did not cause habituation of the HPA axis to subsequent binge EtOH exposure in adulthood but, on the contrary, it increased the sensitivity of the HPA axis to adult EtOH exposures. This indicates that binge EtOH exposure in adolescence may potentially lead to increased risk for developing mood disorders in adulthood

CHAPTER TWO

BINGE-PATTERN ALCOHOL EXPOSURE DURING PUBERTY INDUCES SEXUALLY DIMORPHIC CHANGES IN GENES REGULATING THE HPA AXIS

(PRZYBYCIEN-SZYMANSKA ET AL, AM J PHYSIOL. ENDOCRINOL METAB 298; E-320-E328, 2010)

Introduction

Alcohol abuse during adolescence is a growing fundamental health concern in the United States. According to the US Department of Health and Human Services, boys on average have had their first drink before age 11, and girls before age 13; with the overall statistics showing that 41% of teenagers have had their first drink by age 14. Underage drinkers typically adopt a “binge” pattern of alcohol consumption, defined by the National Institute on Alcohol Abuse and Alcoholism as heavy, episodic drinking in which enough alcohol is consumed in one sitting to bring the blood alcohol concentration (BAC) >0.08 g/100 g (White, Kraus et al. 2006). During adolescence, significant neural remodeling occurs as evidenced by changes in cortical gray matter (Giedd, Blumenthal et al. 1999; Paus, Zijdenbos et al. 1999; Lenroot and Giedd 2006), neurogenesis (Raymond, Kucherepa et al. 2006), and increased synaptic connectivity (Cunningham, Bohn et al. 1990; Woo, Pucak et al. 1997; Cunningham, Bhattacharyya et al. 2002; Sisk and Zehr 2005), raising the

possibility that alcohol consumption during this critical period can lead to long-term neurobiological and behavioral defects.

One neurological system that undergoes extensive plasticity during pubertal development is the hypothalamo-pituitary-adrenal (HPA) axis (Romeo 2003; Romeo, Lee et al. 2004; Romeo, Bellani et al. 2006; Romeo and McEwen 2006). Under normal physiological conditions, an acute psychological or physical stressor activates the HPA axis. Hypothalamic corticotrophin-releasing hormone (CRH) stimulates adrenocorticotrophic hormone (ACTH) release from the anterior pituitary, which, in turn, causes the release of adrenal glucocorticoids. This sequence of events sets up a negative feedback system whereby increased circulating glucocorticoid levels serve to inhibit the additional release of hypothalamic CRH. Importantly, alcohol consumption can alter the expression of genes involved in mediating the stress response of the HPA axis. For instance, Rivier and Lee (Rivier and Lee 1996) demonstrated that acute ethanol (EtOH) administration to adult rats increased the transcriptional activity of hypothalamic CRH and arginine vasopressin (AVP) neurons, as measured by increased CRH and AVP heteronuclear (hn) RNA following a single dose of EtOH. In addition, the release of ACTH from the pituitary gland in response to EtOH was blocked when CRH and AVP antagonists were used concomitantly (Rivier and Lee 1996). These results show that acute EtOH exposure activates the HPA axis and the effects of EtOH are likely mediated by both CRH and AVP.

AVP is a multifunctional neuropeptide critical for mediating both stress and anxiety responses (Wigger, Sanchez et al. 2004; Egashira, Tanoue et al. 2007).

First discovered as antidiuretic hormone, AVP is synthesized in the paraventricular nucleus (PVN), supraoptic nucleus (SON), bed nucleus of stria terminalis (BST), amygdala (AMY), and suprachiasmatic nucleus (SCN). Neurons that synthesize AVP in the parvocellular division PVN project to the median eminence and facilitate the synergistic actions of AVP and CRH following stressful stimuli by enhancing ACTH and glucocorticoid release (Dickstein, DeBold et al. 1996). Several lines of evidence suggest that acute or chronic alcohol exposure might lead to increased displays of anxiety behavior. Correlative studies have demonstrated that over 50% of patients with alcohol dependency also have anxiety-related or depression-related psychiatric disorders, and these types of disorders are often associated with an abnormal stress response. Interestingly, female alcoholics have a higher incidence of clinically diagnosed anxiety disorders compared with male alcoholics (Zilberman, Tavares et al. 2003; Epstein, Fischer-Elber et al. 2007), possibly because of the inherent sex differences in the stress responses of the HPA axis (Becker, Monteggia et al. 2007; Handa, Zoeller et al. 2007). Furthermore, repeated episodes of acute EtOH exposure increased anxiety behaviors in peri-pubertal animals, as measured by increased latency to explore a novel object in the retention-based passive avoidance task (Popovic, Caballero-Bleda et al. 2004). Direct effects of EtOH on AVP gene expression in the hypothalamus is one possible mechanism by which EtOH could alter anxiety behaviors, and, in fact, acute EtOH administration has been shown to increase the amount of AVP hnRNA in adult rats (Rivier and Lee 1996). Taken together, these studies show

that AVP is an important modulator of normal HPA axis function that can be disrupted by alcohol exposure.

Our current understanding of how EtOH exposure, especially a binge pattern of EtOH exposure, affects the brain during pubertal development is very limited. In this study, we tested the hypothesis that a binge pattern of EtOH exposure during pubertal development stimulates the stress response by increasing circulating levels of corticosterone (CORT) and upregulating CRH and AVP mRNA levels in the PVN of the hypothalamus in male and female rats. Our results showed a striking sex difference in the response to binge EtOH exposure for most parameters measured. Overall, the results from our study confirm that a binge pattern of EtOH exposure during puberty significantly alters the expression of genes important or regulating the HPA axis and might lead to a higher risk of developing anxiety disorders in adulthood.

Results

General Approach

In order to investigate effects of EtOH exposure during puberty on stress responsiveness of the HPA axis during this time period, peri-pubertal male and female rats were treated either with saline, acute EtOH or binge EtOH exposure between PND 37 and 44 or remained untreated during the course of the experiment (see Fig 2). On the last day of treatments (PND 44), 1.0 h after the last EtOH administration, animals were sacrificed and brains and trunk blood were collected. Plasma was isolated and used for further hormone and blood

alcohol concentration (BAC) measurements. Brains were rapidly frozen, sectioned on a freezing microtome and PVN and SON were microdissected for CRH and AVP mRNA measurements using qRT-PCR (see Chapter 7, General Methods section for detailed description).

Binge Exposure Paradigm During Puberty

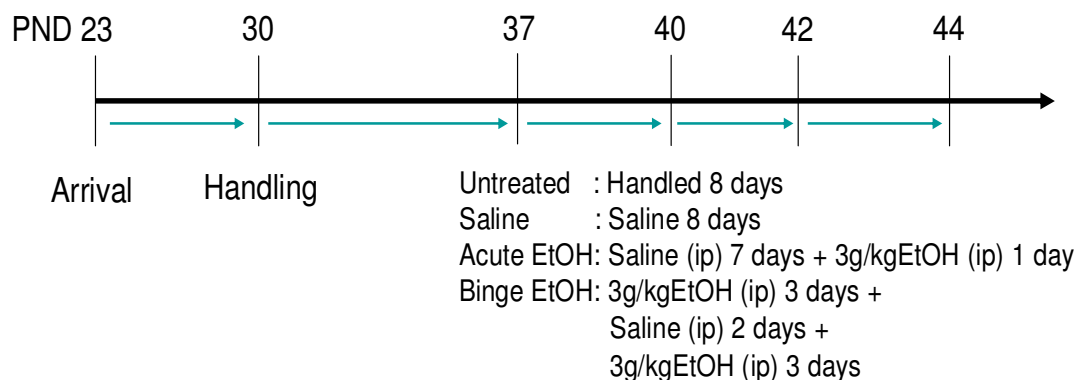

Fig 2. *Binge alcohol exposure paradigm employed in these studies.*

After 1 week of acclimation period and 1 week of daily handling, animals were divided into one of 4 groups and started following treatments: 1) **UNTREATED** 2) **SALINE ONLY** (intraperitoneal (ip) saline injection once/day for 8 days), 3) **ACUTE EtOH** (saline injection once/day for 7 days; one 3g/kg EtOH injection on day of sacrifice), 4) **BINGE EtOH** (EtOH injections once/day for 3 days (3g/kg), saline injection once/day for 2 days, EtOH injection once/day for 3 days). The same paradigm was used in all studies, regardless of the age.

Alcohol exposure had no effect on body weights

Body weight measurements were obtained every other day during the duration of treatments in both males and females treated either with saline, acute EtOH or binge EtOH or that remained untreated during the course of the experiment (see Fig 2 and General Methods section in Chapter 7 for detailed description of binge EtOH exposure paradigm).

Repeated measured mix AVOVA revealed that neither EtOH exposure (acute or binge) nor saline injections caused males (Fig 3A) or females (Fig 3B) to lose weight during the duration of treatments indicating that neither EtOH nor stress inhibited growth of animals.

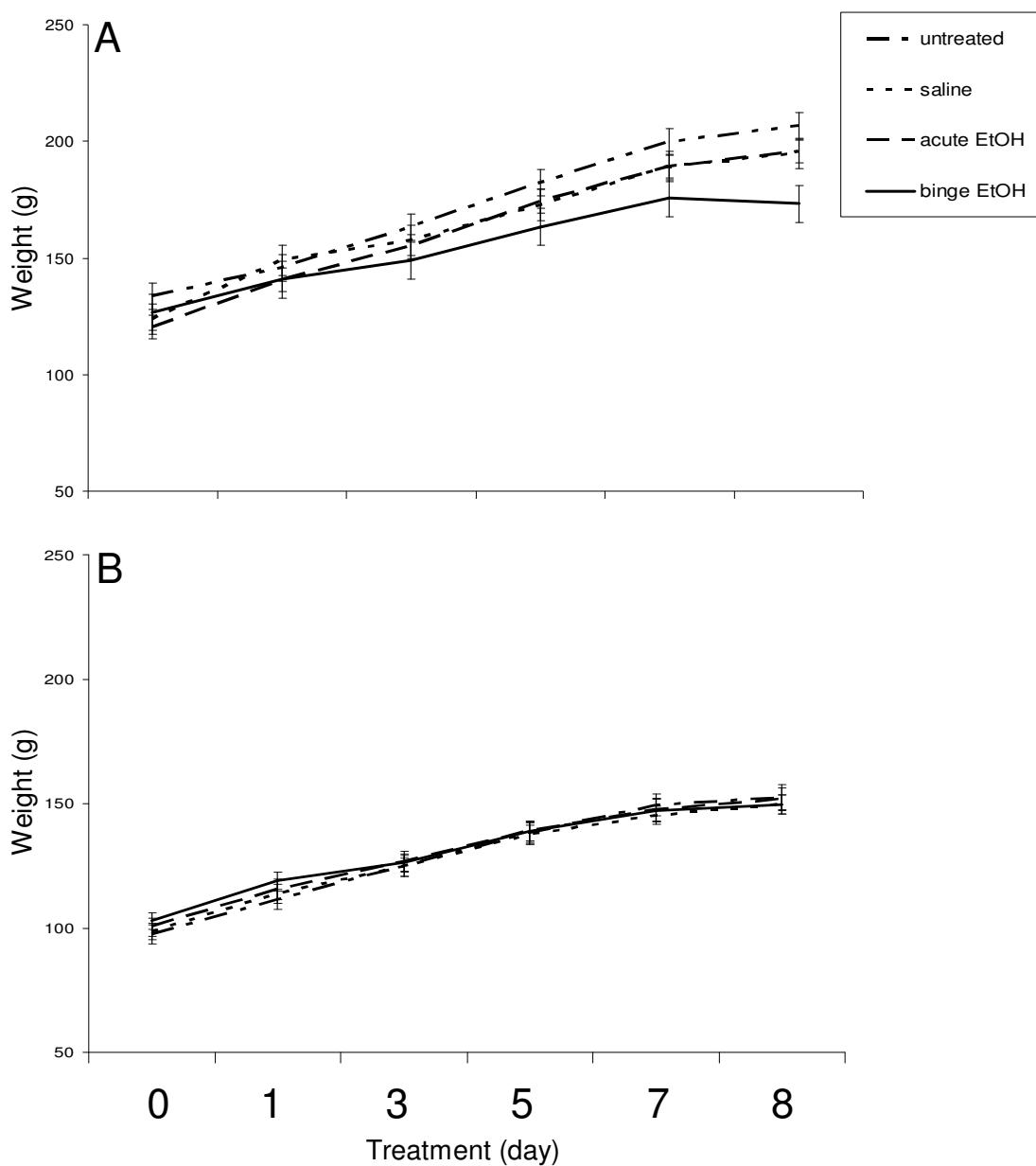

Fig 3. Effects of ethanol treatment on body weight during pubertal development (post natal day (PND) 37-44). Mean body weights of male (A) and female (B) animals untreated or treated with daily IP injections of saline, saline + one day EtOH (acute), or binge EtOH paradigm.

In these experiments, EtOH exposure paradigm resulted in average blood alcohol concentrations of 159.42 ± 14.38 and 143.92 ± 21.45 mg/dl in males and females (Fig 4), respectively. Acute (single dose) EtOH exposure resulted in BAC of 146.91 ± 8.69 and 230.4 ± 36 mg/dl in males and females (Fig 4), respectively and in both cases the values were significantly different from BAC in untreated and saline groups (below the limit of detection, $p < 0.001$). These values are consistent with the defined BAC threshold of binge drinking.

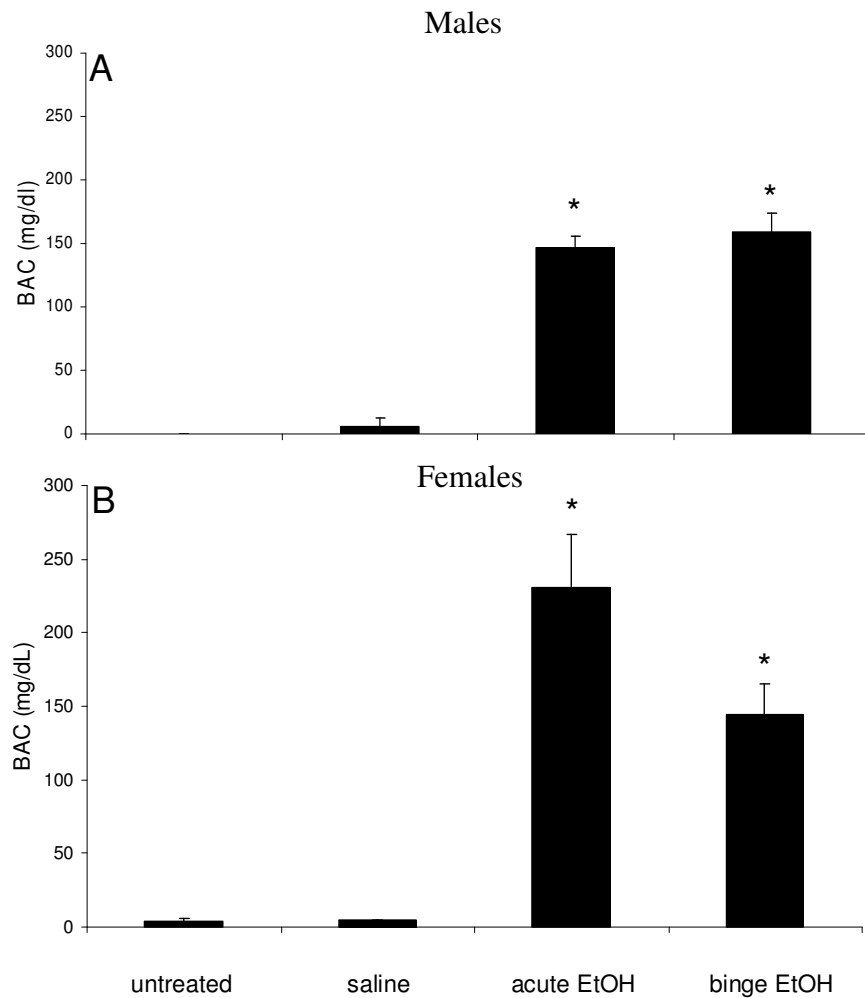

Fig 4. Effects of EtOH treatments on blood alcohol levels in male and female rats. Blood alcohol concentrations (BAC) 1.0 h post-injection in males (A) and females (B) treated with saline, acute EtOH or binge EtOH. Data expressed as mean EtOH mg/dl. * indicates statistically significant difference compared to untreated control ($P < 0.05$).

Binge alcohol exposure decreased testosterone levels in males but did not change estradiol levels in females.

To determine the effects of binge EtOH exposure during puberty on gonadal steroid hormone levels, T and E2 were measured on the last day of treatments (see Chapter 7, General Methods section for detailed description of hormone measurements). In males, binge, but not acute, EtOH exposure significantly decreased T levels in the plasma (Fig 5A; $p < 0.001$) compared to untreated and saline groups. T levels were 463.84 ± 43.54 pg/ml in untreated, 435.35 ± 31.13 pg/ml in saline, 391.27 ± 55.42 pg/ml in acute EtOH and 264.88 ± 58.59 pg/ml in binge EtOH groups. On the other hand, neither of the EtOH treatments changed the E2 levels in females (Fig 5B). The values were 22.91 ± 3.74 pg/ml, 24.76 ± 4.84 pg/ml, 25.34 ± 7.11 pg/ml and 19.25 ± 2.95 pg/ml in untreated, saline, acute EtOH and binge EtOH groups, respectively. Even though there was no change in E2 level due to treatments, levels observed in females indicate that pubertal transition was initiated (Andrews, Advis et al. 1980; Sisk, Richardson et al. 2001). Since the E2 level did not increase beyond the level required for the occurrence of the first proestrus (Andrews, Advis et al. 1980), females in our experiments did not start regular cycling.

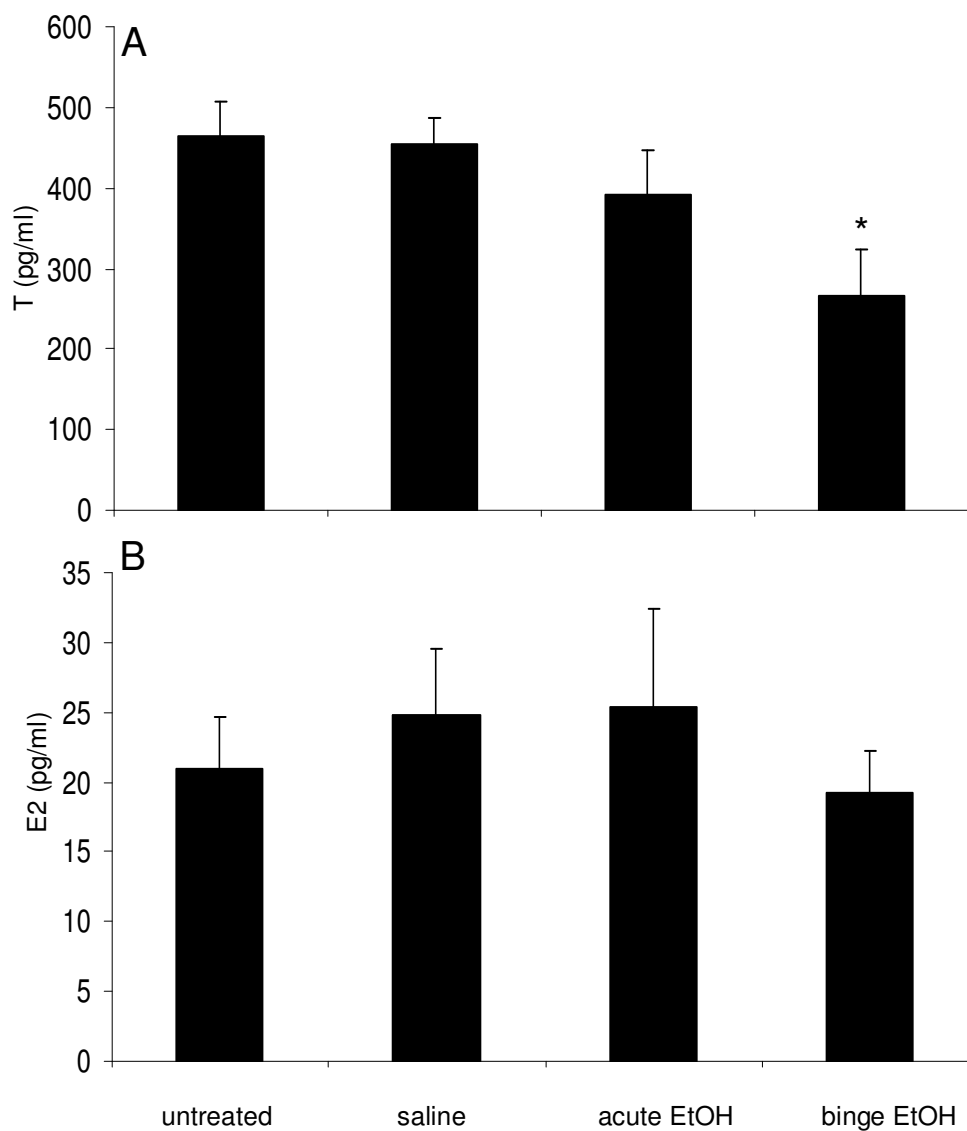

Fig 5. *Effects of EtOH treatment on gonadal steroid hormone levels.* Plasma concentrations of (A) testosterone [T] and (B) estradiol [E2] 1.0 h after IP injection of saline, acute EtOH or binge EtOH treatments. Untreated animals received no injection. Data expressed as T or E2 pg/ml. * indicates statistically significant difference compared to untreated control ($P < 0.05$).

Effects of acute and binge alcohol exposure on circulating CORT levels.

To determine circulating CORT levels on the last day of treatments, I measured plasma CORT levels using RIA (see Chapter 7, General Methods section for detailed description of hormone measurements). In males and females, acute and binge EtOH exposure significantly increased plasma CORT levels (Fig 6). In males, CORT levels in acute and binge EtOH groups were 88.62 ± 12.65 pg/ml and 44.83 ± 11.66 ng/ml, respectively. Those values were significantly higher than values measured in untreated and saline groups (2.19 ± 0.58 ng/ml and 5.82 ± 1.4 ng/ml, respectively; $p < 0.001$) (Fig 6A). However, CORT levels between the two EtOH groups were also significantly different with the binge group having 50% lower CORT levels compared with acute EtOH group ($P < 0.05$) (Fig 6A).

As in males, both acute and binge EtOH exposures significantly increased plasma CORT levels in females (Fig 6B; $p < 0.001$). In acute and binge EtOH exposure groups CORT levels were 469.67 ± 11.74 ng/ml and 365.04 ± 19.63 ng/ml, respectively which were significantly different from values measured in untreated and saline groups (0.05 ± 0.05 ng/ml and 66.89 ± 29.64 ng/ml, respectively) (Fig 6B). As in males, binge EtOH exposure significantly decreased CORT level compared to acute EtOH exposure ($p < 0.001$). In addition, females had significantly higher plasma CORT levels compared to males after EtOH exposure (Fig 6B, $p < 0.001$).

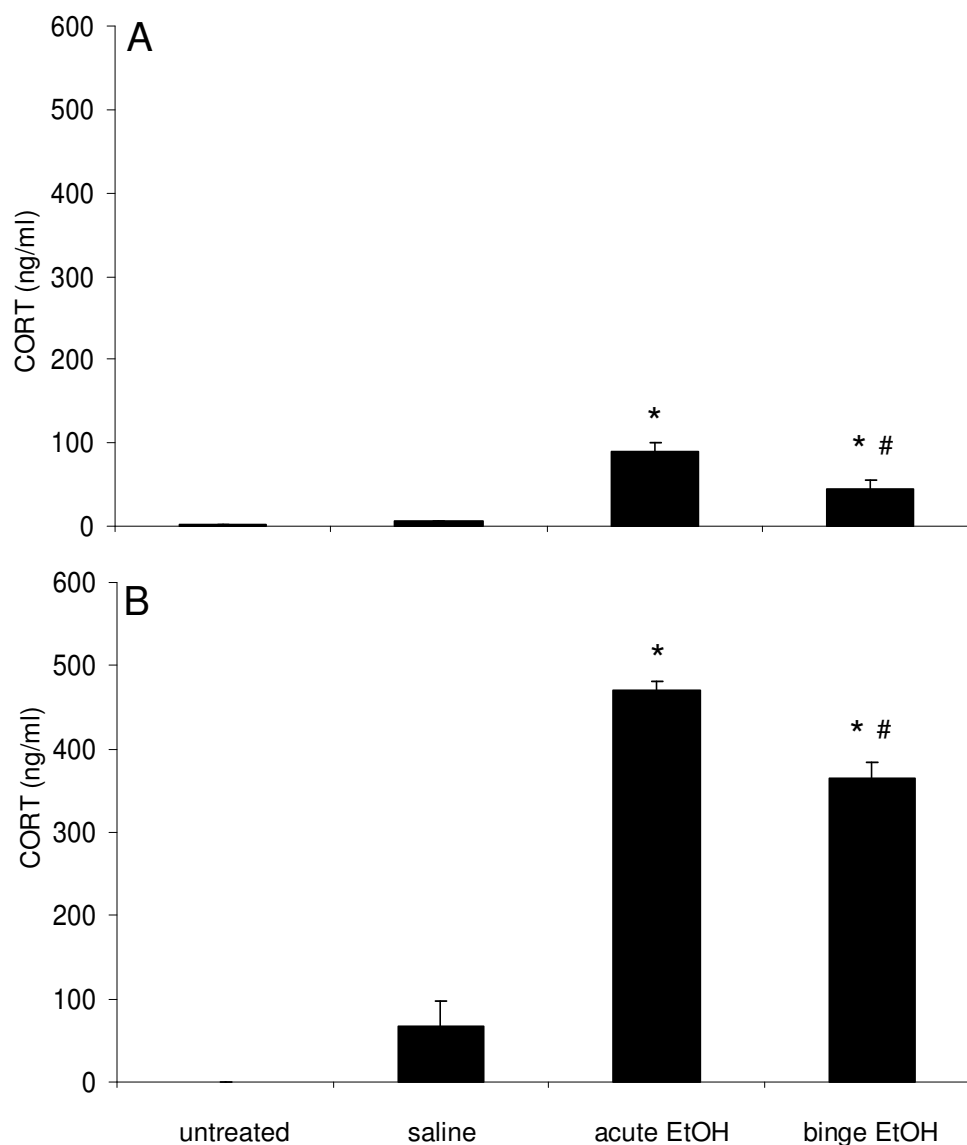

Fig 6. Effects of EtOH treatments on blood corticosterone levels in male and female rats. Plasma corticosterone (CORT) levels in males (A) and females (B) 1.0 h after IP injection of saline, acute, or binge EtOH treatments. Untreated animals received no injection. Data expressed as mean CORT ng/ml of blood. * indicate statistically significant difference compared to untreated and saline controls; # indicated significant difference compared to acute EtOH ($P < 0.05$).

Binge alcohol exposure changes the expression of CRH and AVP in the PVN in males but not in females.

In order to investigate the effects of EtOH exposure during puberty on the expression of genes involved in stress and anxiety responses in males and females (see Chapter 7, General Methods section for detailed description), CRH and AVP mRNA expression was measured using qRT-PCR. No significant differences were observed between untreated and saline control groups in either of the sexes (Fig 7). Only binge, and not acute, EtOH exposure significantly increased the expression of CRH (Fig 7A, $p < 0.05$) and AVP mRNA (Fig 7B, $p < 0.05$) in the male PVN. The expression of CRH and AVP mRNA in acute EtOH exposure group was the same as in the saline group indicating that the effect observed in the binge EtOH group is due to repeated EtOH exposure.

On the other hand, there were no significant differences among treatment groups in the expression of CRH and AVP mRNA in the PVN of female rats (Fig 7C, D) which indicates a sex difference in responsiveness of peri-pubertal HPA axis to EtOH exposures.

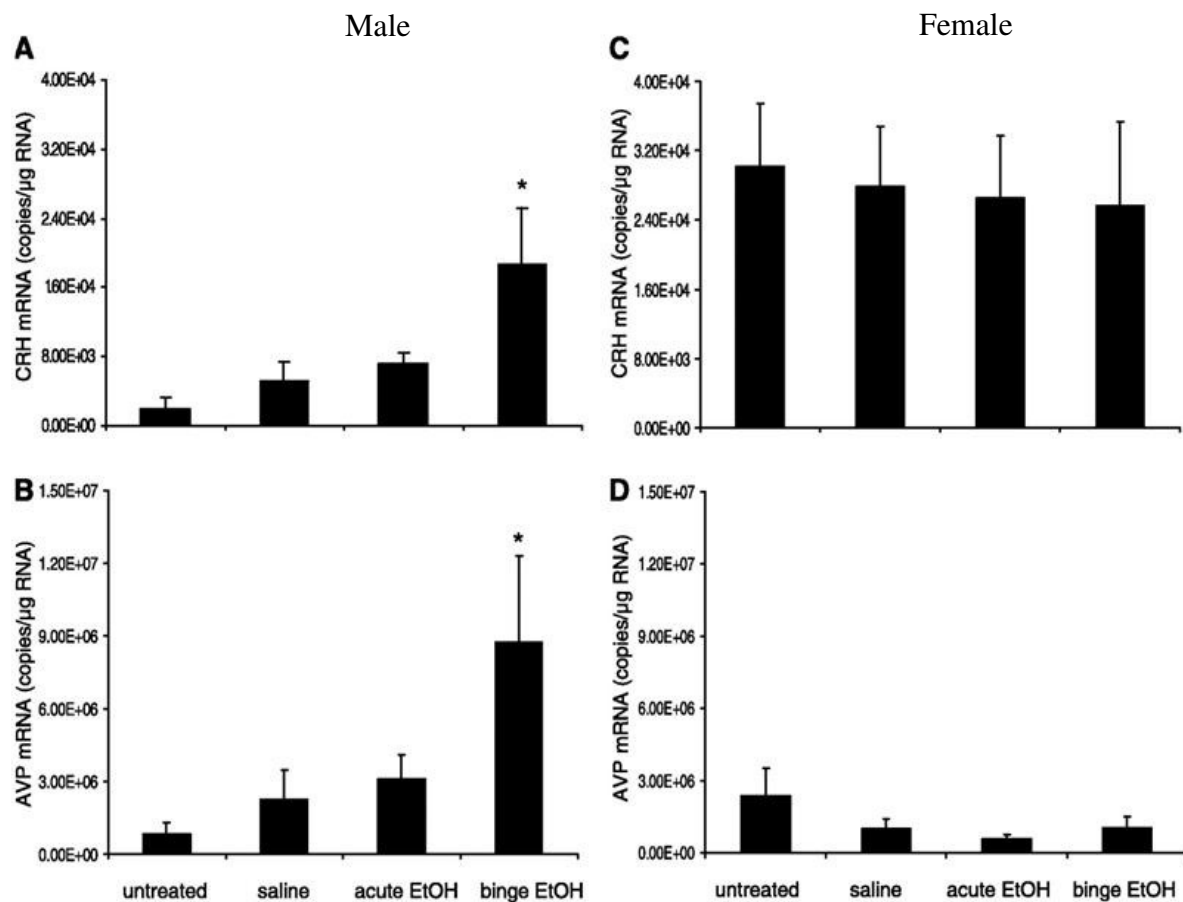

Fig 7. Effects of EtOH treatments on CRH and AVP gene expression in the PVN of male and female rats. CRH and AVP mRNA expression in the PVN of peri-pubertal male (A and B, respectively) and female (C and D, respectively) rats treated with saline, acute, or binge EtOH. Data expressed as mRNA copies/ μ g total RNA. * indicates statistically significant difference compared to untreated control ($P < 0.05$).

Alcohol exposure does not change the expression of AVP in the SON

In order to confirm that the observed changes in the expression of AVP mRNA in PVN of male rats were not exclusively due to the reported diuretic effect of EtOH, I measured the expression of the AVP mRNA in the SON, region of the brain involved in controlling water balance. There were no differences in the expression of AVP mRNA in the SON either in males (Fig 8A, $p = 0.319$) or in females (Fig 8B, $p = 0.652$) suggesting that the change in the AVP mRNA observed in the PVN reflected change in the population of AVP-expressing cells responsible for mediating stress and anxiety.

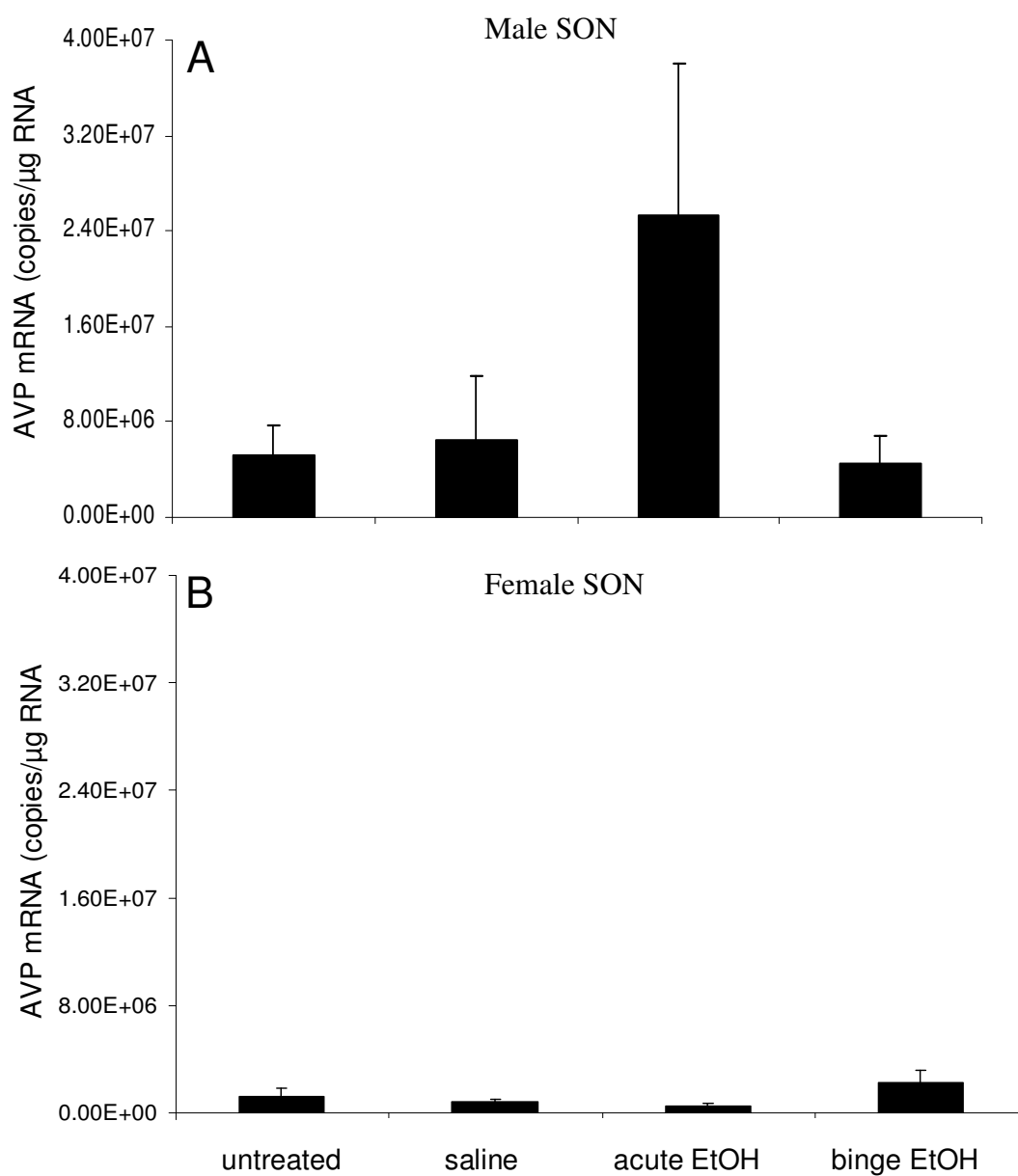

Fig 8. Effects of EtOH treatments on AVP gene expression in the SON of male and female rats. AVP mRNA expression in SON of peri-pubertal male (A) and female (B) rats treated with saline, acute, or binge EtOH. Data expressed as AVP mRNA copies/ μ g total RNA.

Discussion

Our current understanding of how alcohol consumption affects the developing postnatal brain is severely limited. To date, specific molecular and neuroendocrine markers that are activated by alcohol during puberty have not been identified. Elucidating the neurobiological targets of alcohol resulting from a binge pattern of consumption during adolescence is critical for understanding the long-term behavioral consequences and potential development of mental health disorders. Therefore, the goal of this study was to investigate the effects of binge-pattern EtOH exposure during puberty on the expression of specific neuroendocrine factors that mediate stress and anxiety, including CRH and AVP. My data reveal the novel findings that peri-pubertal binge-pattern, but not acute, EtOH exposure increased the expression of CRH and AVP mRNA in the PVN of peri-pubertal male rats, yet had no effect in peri-pubertal females (Fig 9). Data presented here indicate that the effects of alcohol on the HPA axis are sex-specific and dependent on repeated high-dose exposures. Moreover, CORT levels were increased significantly in response to both acute and binge EtOH exposure paradigms (Fig 9), suggesting that EtOH is a potent activator of the HPA axis during pubertal development. Notably, there was no sex difference in the CORT response to EtOH, and, under binge-pattern exposure conditions, the animals appeared to habituate to the effects of the stressor. Last, we have shown that binge-pattern EtOH exposure decreased sex steroid hormone levels in male, but not female, rats and that the observed effects of EtOH on AVP gene expression were unlikely because of the diuretic effects of EtOH but, instead,

probably specific for the population of AVP-expressing neurons that regulate stress and anxiety.

Acute and binge-pattern EtOH exposure increased plasma CORT levels in our study, confirming previous reports that EtOH is a potent activator of the stress response in adults. Ogilvie and Rivier (1997) showed that acute EtOH administration increased CORT levels which peaked at 15 min. post EtOH injection and were sustained until 1.0 h after the injection (Ogilvie and Rivier 1997). However, I showed that plasma CORT levels in the binge EtOH groups were significantly lower compared to the acute EtOH exposure groups, suggesting that the HPA axis habituated to the stressful stimuli of multiple doses of EtOH. Also, females had higher plasma CORT levels after EtOH exposure compared with males, indicating that females were more sensitive to EtOH administration than males. These data are in agreement with multiple studies demonstrating that there are gender differences in responsiveness to alcohol, with females tending to achieve higher CORT levels compared with males given the same dose of EtOH (Rivier 1993; Ogilvie and Rivier 1996).

SUMMARY: Effects of binge alcohol exposure in puberty

Males (PND 37-44):

- Repeated binge EtOH exposure INCREASED CRH and AVP mRNA in the PVN
- Both acute and repeated binge EtOH exposures INCREASED plasma CORT levels, habituation effect after repeated binge EtOH exposure present

Females (PND 37-44)

- NO CHANGES in the CRH and AVP mRNA in the PVN due to treatments
- Both acute and repeated binge EtOH exposures INCREASED plasma CORT levels, habituation effect after repeated binge EtOH exposure present

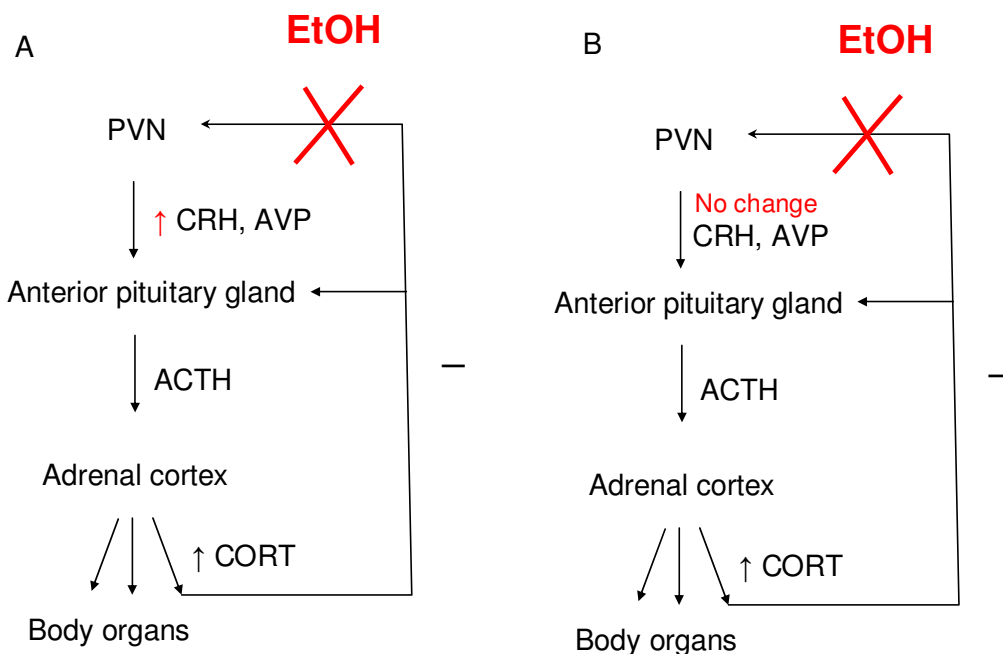

Fig 9. Summary of results described in Chapter 2. In males (A) binge EtOH exposure ↑ CRH and AVP mRNA in the PVN and ↑ plasma CORT levels. In females (B), binge EtOH exposure did not induce changes in the CRH and AVP mRNA in the PVN but ↑ plasma CORT levels. These data indicate that glucocorticoid (CORT) negative feedback is dysregulated in both males and females but mechanisms behind these effects are different.

Acute EtOH consumption, chronic EtOH consumption, and withdrawal from EtOH dependency have all been associated with dysregulation of the HPA axis in adults at multiple levels including hypothalamic CRH and AVP systems. CRH and AVP neurons in the PVN are required for some of the effects of EtOH (Rivier, Bruhn et al. 1984; Hoffman and Dave 1991; Rivier 1993; Ogilvie and Rivier 1996; Rivier and Lee 1996; Rivier, Rivier et al. 1996; Ogilvie, Lee et al. 1997; Ogilvie, Lee et al. 1997; Ogilvie and Rivier 1997; Ogilvie, Lee et al. 1998; Silva, Paula-Barbosa et al. 2002; Li, Kang et al. 2005). For instance, studies in adult rats have shown that acute alcohol administration increased circulating levels of ACTH (Rivier, Bruhn et al. 1984). This effect was dependent on the synergistic action of CRH and AVP, since pharmacological antagonism of the CRH and AVP receptors abolished the response (Rivier, Rivier et al. 1984; Rivier, Rivier et al. 1984; Ogilvie, Lee et al. 1997). Similarly, chronic alcohol treatment resulted in a 33% decrease in the number of AVP-expressing neurons in the SCN (Madeira, Andrade et al. 1997) and altered the diurnal rhythm in circulating glucocorticoids (Tabakoff, Jafee et al. 1978). AVP neurons in the SCN convey circadian information to the PVN and other extrahypothalamic brain nuclei. Moreover, the circadian expression of AVP in the SCN modulates the diurnal rhythm of circulating glucocorticoids (Isobe and Isobe 1998). Our data showing that EtOH administration alters CRH and AVP mRNA in peri-pubertal male rats are consistent with the observations in adult animals. Notably, in our study, a single dose of acute EtOH failed to increase CRH and AVP mRNA in the PVN despite inducing a dramatic increase in circulating CORT levels. These data

suggest that the EtOH-induced upregulation of these genes occurs as a result of repeated EtOH exposure, as would be achieved with a binge pattern of alcohol consumption. It remains to be determined whether there are long-lasting behavioral or physiological deficiencies associated with these changes in gene expression. Nevertheless, there is a growing body of evidence to suggest that neurite remodeling, neurogenesis, and synaptic connectivity are prominent developmental events during puberty (Sisk and Zehr 2005). Accordingly, it is logical to assume that repeated and excessive alcohol use during this critical stage of development could lead to permanent alterations in the morphological and/or neurochemical circuitry that might be organized during this time. These changes could, in turn, have negative consequences on normal adult behavior patterns, since brain morphology and neurochemistry are intimately linked with behavior.

The neuropeptide AVP is a compelling candidate for mediating the underlying neuroendocrine basis of the sexually dimorphic effects of alcohol. First, central release of AVP from the PVN, BST, and AMY mediates a broad range of social behaviors and participates in modulation of the stress response. In both males and females, AVP augments the stress response by acting synergistically with CRH, which can be altered by a variety of factors, including gonadal steroid hormones and alcohol (Handa, Corbier et al. 1985; McCarthy, McDonald et al. 1996; Albeck, McKittrick et al. 1997; Erkut, Pool et al. 1998; Engelmann, Wotjak et al. 2000; Blanchard, Griebel et al. 2005; Ring, Malberg et al. 2006). Moreover, AVP and the AVP receptors are differentially regulated by

gonadal steroid hormones in a sex- and age-dependent manner (Sladek, Swenson et al. 2000; Bale, Davis et al. 2001; Quadros, Pfau et al. 2002; Yue, Mutsuga et al. 2006; Pak, Chung et al. 2009). For example, AVP expression in the BST is greater in males than females (Miller, Vician et al. 1989), and this sex difference is abolished by castration and restored with testosterone replacement, an effect that is accomplished mainly by testosterone-derived 17β -estradiol (Han and De Vries 2003). To date, little is known about the maturation of the central AVP system, including the temporal, sex-specific, and hormonal influences that occur during pubertal development. Previously, we showed that AVP mRNA expression in the BST and AMY was differentially regulated in pre- and post-pubertal animals (Pak, Chung et al. 2009). Here, we have demonstrated prominent sex-dependent effects of binge-pattern EtOH administration on AVP mRNA levels during the pubertal transition. Our study showed that, in males, there was a significant increase in AVP mRNA following binge-pattern, but not acute, EtOH administration. Conversely, there were no effects on AVP in females using the same binge-pattern paradigm. It is important to note that, although the binge-pattern EtOH treatments significantly reduced testosterone levels, there was no effect on estradiol levels, suggesting that the EtOH effects on gonadal steroid hormones alone are not sufficient to explain these sex differences.

Developmental changes in HPA axis reactivity have been well documented. Most striking is the observation that CORT and ACTH levels take much longer to return to baseline in juvenile compared with adult animals subjected to a variety of stressful stimuli (Vazquez and Akil 1993; Romeo, Bellani

et al. 2006). It is well known that males and females achieve sexual maturity at different rates with respect to reproductive function, but whether there are sex differences in the rate of HPA axis maturation during puberty is unknown. The majority of studies investigating the maturation of the HPA axis during pubertal development have focused strictly on comparisons between the pre- and post-pubertal states, but not at time points in between (Romeo, Bellani et al. 2006). However, one study in human adolescents showed that there were sex differences in the cortisol response to a CRH challenge (Stroud, Papandonatos et al. 2004). In general, girls achieved peak cortisol levels later and had a slower return to baseline following a CRH challenge compared with boys (Stroud, Papandonatos et al. 2004), a difference that persisted throughout all Tanner stages of development. These data suggest that sex differences in HPA axis reactivity might not necessarily be because of a differential timing in HPA axis maturation between males and females but rather because of inherent differences that are perhaps organized before pubertal onset. Recent evidence from Evuarherhe and colleagues (Evuarherhe, Leggett et al. 2009; Evuarherhe, Leggett et al. 2009) support this possibility. In their study, 17β -estradiol inhibited the CORT-induced response to restraint stress in pre-pubertal female rats but enhanced the response post-pubertal. Importantly, the adult response to restraint stress in the presence of 17β -estradiol was still enhanced regardless of whether the animals were ovariectomized before, or following, puberty. These data indicate that the maturation of the HPA axis in females might be programmed before pubertal onset and that it is independent of circulating gonadal steroid

hormones during pubertal development. At this time, there are no empirical data to suggest that the HPA axis matures at different rates in males compared with females, and, in fact, the evidence available from humans would predict that they likely mature at similar rates. However, we cannot rule out the possibility that the differences we observed might be because of discrepancies in the relative state of HPA axis maturation between males and females. Nevertheless, our data demonstrate a clear distinction between the effects of repeated EtOH exposure during the pubertal transition that might lend some insight into the time course for the development of the HPA axis between males and females. Furthermore, our data have demonstrated that repeated EtOH exposure during the pubertal transition results in a dysregulation of the HPA axis akin to that of a chronic stressor in adults.

In this study, both males and females began receiving injection treatments on *day 37*, which were completed on day 44, falling within the defined peri-pubertal period for both males and females (30–45 days of age; (Laviola, Adriani et al. 2002)). In general, female rats undergo pubertal onset (as measured by vaginal introitus) at 32–35 days of age, with regular estrous cyclicity and mature ova first occurring between 43 and 47 days of age (Sisk, Richardson et al. 2001; Sisk and Zehr 2005). Unlike females, in which puberty is defined as the 1st day of vaginal introitus, males do not have a reliable external benchmark that defines pubertal onset, since the commonly used external marker of preputial separation is dependent upon increased testosterone levels. The binge pattern alcohol exposure paradigm employed in our experiments did not inhibit feeding behavior

or normal growth patterns that occur during pubertal development. Moreover, it allowed us to distinguish the pharmacological effects of EtOH from the effects of other nonspecific stressors, such as handling and injections. This binge EtOH exposure paradigm has been previously shown to be reliable for testing the effects of alcohol using an exposure pattern that is typical for adolescents (Lauing, Himes et al. 2008). In addition, it has been shown that the intraperitoneal injection of EtOH, employed in our paradigm, does not result in significantly different blood alcohol concentrations compared with oral gavage in adolescent Wistar rats (Walker and Ehlers 2009).

Although it was not possible to separate the parvocellular and magnocellular divisions of the PVN in our tissue punch sample preparations, we are confident that the EtOH-induced changes in AVP expression accurately reflect changes in the AVP-expressing neurons associated with regulation of the HPA axis, and not in those responsible for osmoregulation for the following reasons. First, we showed that there were no changes in the expression of the AVP mRNA in the SON, a region where AVP is primarily responsible for regulating fluid homeostasis. Second, there was no effect of EtOH in the acute-treated group, and, since fluid homeostasis is an immediate and not cumulative physiological response, any diuretic effect of EtOH would have been observed in the acutely treated groups. Third, if the effects of EtOH on AVP expression were because of an osmoregulatory effect, we would have expected to see a significant increase in the females, as well as the males. Finally, our data are in agreement with previous studies showing that there were no changes in AVP

expression in the magnocellular division of the PVN 3.0 h after an acute EtOH administration (Ogilvie, Lee et al. 1997).

Alcohol is a potent neurotoxic agent that induces widespread cell death in the developing brain (Silva, Paula-Barbosa et al. 2002; Chu, Tong et al. 2007). Exciting new data have revealed that AVP has an important neuroprotective role in the PVN. Chen and colleagues (Chen, Volpi et al. 2008; Chen, Liu et al. 2009) have shown that AVP prevented apoptosis in H32 cells, a cell line derived from the PVN, following serum deprivation. These effects were mediated by mitogen-activated protein kinase activated Bad phosphorylation and by protein kinase C α and - β . These data raise the possibility that the physiological role of increased AVP following binge EtOH exposure in males is, in part, to provide cellular protection against repeated EtOH toxicity. In females, on the other hand, 17 β -estradiol is known to be neuroprotective in addition to playing roles in modulating reproductive functions and anxiety responses (Cardona-Gomez, Mendez et al. 2001; Garcia-Segura, Azcoitia et al. 2001; Cunningham, Bhattacharyya et al. 2002; Huppenbauer, Tanzer et al. 2005; Bodo and Rissman 2006; DonCarlos, Azcoitia et al. 2009). Our study showed that there was no increase in AVP mRNA after binge EtOH exposure in females, possibly because there are different mechanisms for neuroprotection in males compared with females.

Taken together, we have identified specific neuroendocrine targets of EtOH in the adolescent hypothalamus following a binge pattern of EtOH exposure. Furthermore, we have demonstrated that the effects of EtOH administration on genes critical for the developing HPA axis are sex specific.

Sexually dimorphic patterns of addictive behavior emerge during adolescence and often persist in adulthood. Patterns of alcohol use during this developmental time period can also lead to permanent changes in brain function that often manifest in adulthood as psychological disorders, such as depression and anxiety. Overall, these data have identified potential genes involved in increased anxiety responses after EtOH exposure and might lead to a better understanding of the mechanisms involved in increased prevalence of anxiety disorders in females compared with males.

CHAPTER THREE

ALCOHOL DYSREGULATES CORTICOTROPHIN-RELEASING-HORMONE (CRH) PROMOTER ACTIVITY BY INTERFERING WITH THE NEGATIVE GLUCOCORTICOID RESPONSE ELEMENT (NGRE) SITE OF THE PROMOTER

Introduction

Alcohol is a potent activator of the hypothalamo-pituitary adrenal (HPA) axis, as manifested by immediate increases in circulating glucocorticoids following exposure (Rivier, Bruhn et al. 1984; Rivier 1993; Ogilvie and Rivier 1996; Ogilvie and Rivier 1997; Ogilvie, Lee et al. 1998; Przybycien-Szymanska, Rao et al. 2010). Moreover, alcoholics are significantly more likely to have diagnosed mood disorders implicating alcohol as a potential endocrine disrupter of the HPA axis (Pompili, Serafini et al.; Zilberman, Tavares et al. 2003). Although the effects of alcohol on HPA function have been well described, our understanding of the molecular mechanisms regulating alcohol effects on the HPA axis remain poorly defined. Corticotrophin-releasing hormone (CRH)-expressing neurons located in the paraventricular nucleus of the hypothalamus (PVN) play a pivotal role in orchestrating the central stress response and proper functioning of these neurons is critical for maintaining a homeostatic state

following a stressful event. The HPA axis is a three-tiered biological system that begins at the highest level with CRH release from the PVN potentiating the release of adrenocorticotrophin hormone (ACTH) from the anterior pituitary gland. ACTH acts, in turn, on the adrenal glands to increase the production and release of glucocorticoid hormones (Papadimitriou and Priftis 2009).

Glucocorticoids (CORT) can then exert negative feedback on both the hypothalamus and pituitary gland to decrease CRH and ACTH release, respectively, allowing for a homeostatic state to be re-established (Figueiredo, Bodie et al. 2003; Ostrander, Ulrich-Lai et al. 2006; Papadimitriou and Priftis 2009).

We previously demonstrated that binge-pattern alcohol exposure during pubertal development increased both circulating plasma CORT levels and CRH mRNA expression in the PVN (Przybycien-Szymanska, Rao et al. 2009), suggesting that alcohol exposure disrupted normal glucocorticoid negative feedback pathways. Glucocorticoid negative feedback is mediated, in part, by the activation of glucocorticoid receptors (GR), which belong to the superfamily of nuclear steroid receptors. Upon activation by glucocorticoids, GRs undergo dimerization, translocate to the nucleus, and modulate gene transcription (Goujon, Laye et al. 1997; Schulkin, Gold et al. 1998; Sapolsky, Romero et al. 2000; Morsink, Steenbergen et al. 2006). In the PVN, GRs are known to decrease CRH gene transcription through signaling at the negative glucocorticoid response element (nGRE), located between -249 and -278 nucleotides upstream from the transcription start site of the CRH promoter (Fig 10). Overall,

glucocorticoids acting through GRs decrease CRH promoter activity thereby, decreasing transcriptional activity of the promoter and decreasing CRH gene expression.

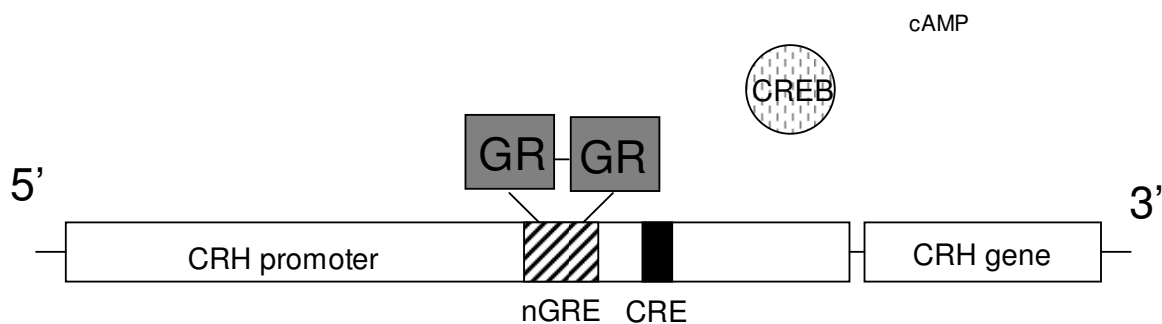

Fig. 10 Schematic model describing normal CRH promoter regulation. In the absence of EtOH when activated GRs interact with nGRE to recruit specific coregulators (not depicted in this diagram), they also prevent signaling at the CRE site of the CRH promoter by CREB thereby decreasing the activity of this promoter and its gene transcription. These interactions between the nGRE and CRE sites are required for glucocorticoid mediated decrease in CRH promoter activity.

Based on our previous observations that binge-pattern EtOH exposure in pubertal rats increased CRH gene expression in the PVN (Przybycien-Szymanska, Rao et al. 2009), we tested the hypothesis that ethanol (EtOH) increases CRH gene expression by directly interfering with glucocorticoid negative feedback at the level of the CRH promoter. The overall goals of this study were to determine if 1) EtOH directly modulates CRH promoter activity and 2), to identify a putative site of action for EtOH on the CRH promoter. Overall, our results showed that EtOH differentially modulated CRH promoter activity in a time-dependent manner. Further, these effects were mediated, in part, through the nGRE site on the CRH promoter. Taken together, our data provide strong evidence that EtOH exposure directly disrupts GR:CRH signaling which, if occurs during adolescence, may be detrimental for proper maturation of the HPA axis.

Results

General approach

In order to investigate molecular mechanisms involved in EtOH effects in the PVN, CRH promoter activity was measured in PVN derived neuronal cell line (IVB) after various EtOH treatments. The CRH promoter-luciferase construct was transfected into the cells and 24.0 h after transfections cells were subjected to different EtOH treatments. First, time course experiments using 12.5 and 100 mM dose of EtOH were performed in the wild type and mutated CRH promoter in order to investigate temporal regulation of CRH promoter activity by EtOH and direct sites on the CRH promoter involved in EtOH effects. Second, possible

EtOH interactions with GR signaling were investigated in cells pre-treated with GR antagonist and then treated with 100 mM EtOH for 0.5, 1.0, 2.0, or 4.0 h. After each specific EtOH treatment regiment, CRH promoter activity was measured using dual luciferase reporter assay. Also, GR expression in IVB cells after EtOH treatments was measured using qRT-PCR.

100 mM EtOH treatment did not induce cell death.

We used a MTT assay to determine whether our highest dose of EtOH treatment (100 mM) induced cell death in our IVB cell line. The results showed that EtOH treatment had a significant effect on cell viability ($F(4,10) = 3.495$, $p=0.049$, $N = 3$, Fig. 11). Contrary to what would be expected, EtOH did not decrease cell viability at any time point measured, rather, it increased mitochondrial activity at 4.0 h time point.

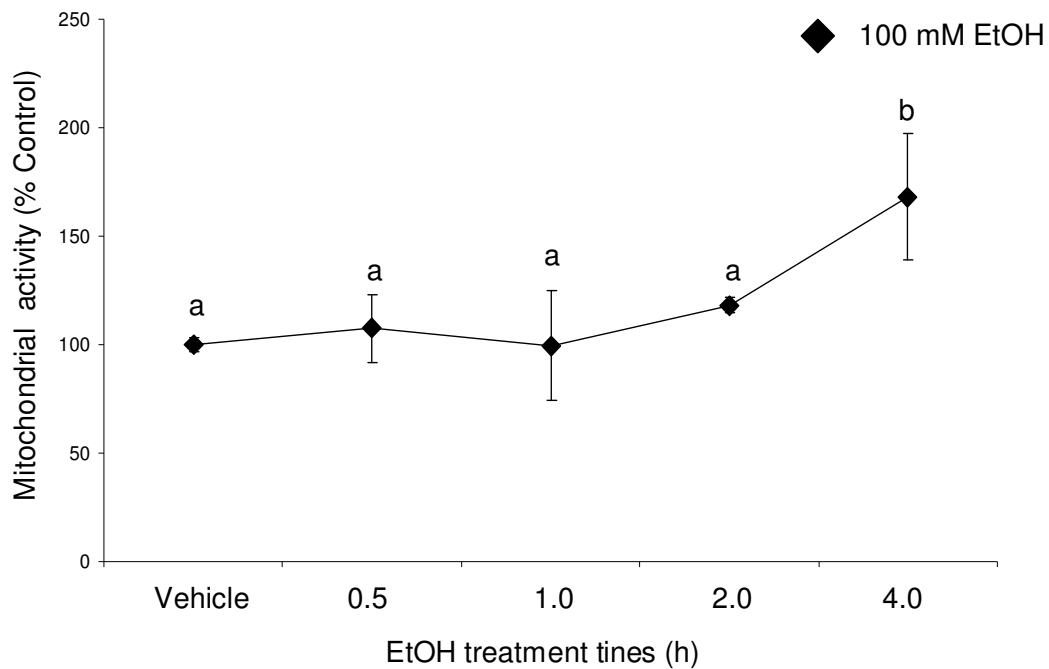

Fig 11. Effects of 100 mM EtOH treatment on cell viability in a neuronal cell line. Mitochondrial activity was measured in IVB cell line after 0.5, 1.0, 2.0 and 4.0 h of 100 mM EtOH treatment. Data expressed as % change of mitochondrial activity relative to vehicle (10% FBS media) treated controls. Dissimilar letters indicate statistically significant difference. More specifically a is different from b but is not different from other a ($P < 0.05$)

EtOH treatment altered CRH promoter activity in a time- dependent manner.

To determine whether EtOH alters CRH promoter activity, we used an *in vitro* reporter gene assay and added EtOH directly to the cell culture media (rat PVN-derived cell line (IVB)). Our results showed that treatment with 100 mM EtOH had a biphasic effect on CRH promoter activity ($F(4,28) = 15.331$, $p < 0.001$, $N = 6$, Fig 12A). Notably, EtOH significantly decreased CRH promoter activity after 0.5 h ($p = 0.002$), whereas EtOH significantly increased the promoter activity after 2.0 h ($p = 0.043$). We then treated the cells with EtOH in the presence of a glucocorticoid receptor antagonist (RU486) in order to ascertain whether EtOH interacted with glucocorticoid negative feedback mechanisms that influences CRH promoter activity. Treatment with RU486 alone significantly decreased baseline promoter activity. Importantly however, RU486 completely abolished the EtOH-induced increase in CRH promoter activity observed after 2.0 h of EtOH treatment, suggesting that EtOH might interact with glucocorticoid receptors to alter CRH promoter activity. Interestingly, treatment with RU486 did not seem to affect the EtOH-induced decrease in CRH promoter activity observed after 0.5 h of EtOH treatment (Fig. 12B).

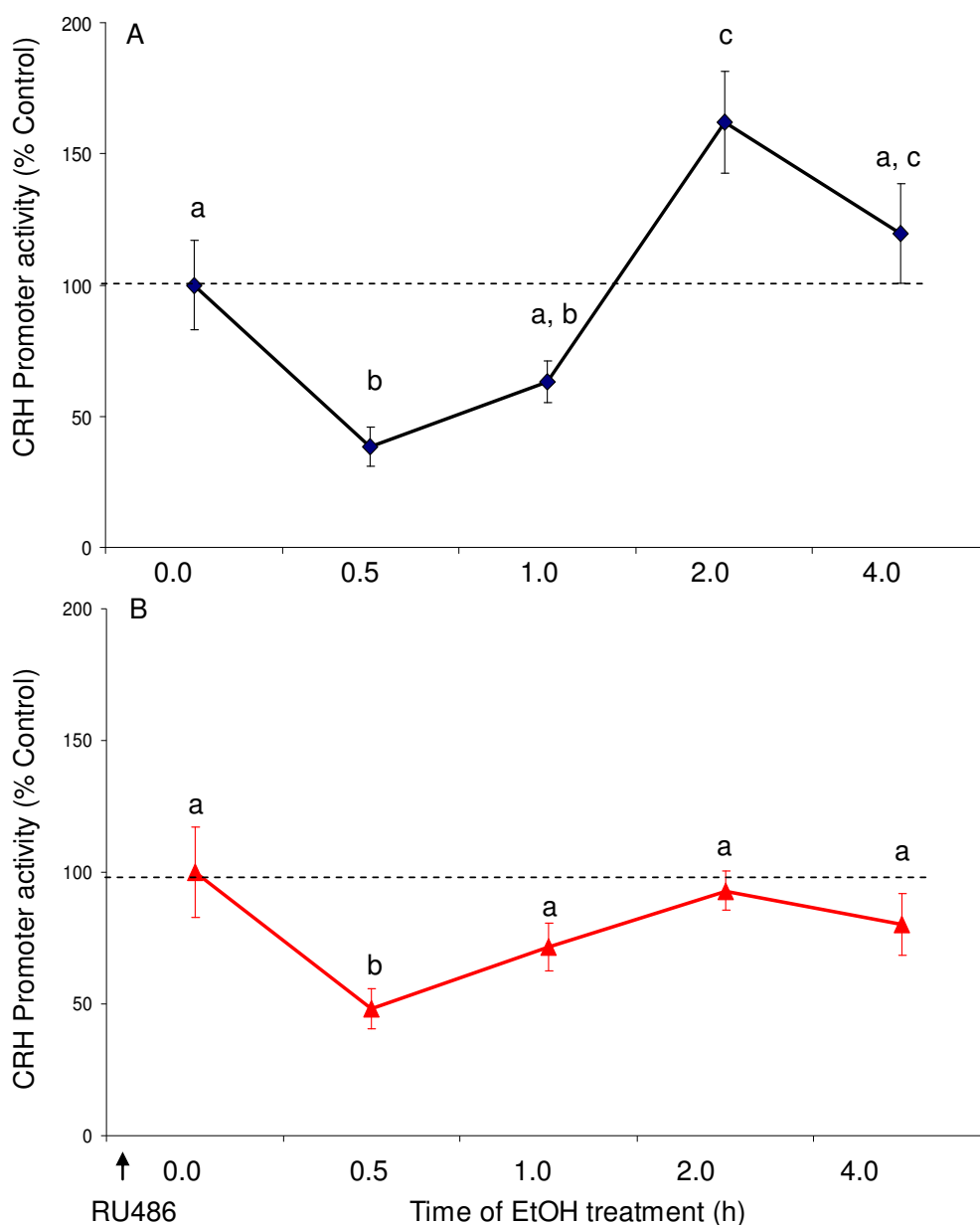

Fig 12. Effects of EtOH treatment (A) and RU486 pre-treatment (B) on CRH promoter activity in a neuronal cell line. CRH-luciferase activity was measured in IVB cell line after treatment with 100 mM EtOH for 0.5, 1.0, 2.0 or 4.0 h or media alone (A, n=6) and after 16.0 h pretreatment with 100nM RU486 and 100 mM ETOH/100 nM RU486 co-treatment for 0.5, 1.0, 2.0 or 4.0 h (B, n=3). Data expressed as % change in luciferase activity of vehicle treated WT control. Dissimilar letters indicate statistically significant

difference between groups. For example, a is significantly different from b, c, d and d b; b is different from a, c, ac, and so on ($P < 0.05$).

EtOH treatment did not have an effect on GR mRNA expression in IVB cells

It is possible that EtOH directly affects GR expression, thereby altering CRH promoter activity. In order to test this we measured GR mRNA expression in IVB cells following treatment with 100 mM EtOH for 0.5 or 2.0 h using qRT-PCR. Our data revealed that there were no changes in GR mRNA expression in IVB cells relative to baseline ($F(4,47)=0.1.889$, $p=0.128$) at any time point tested ($p=0.435$ and $p=0.082$ for 0.5 and 2.0 h, respectively) (Fig 13).

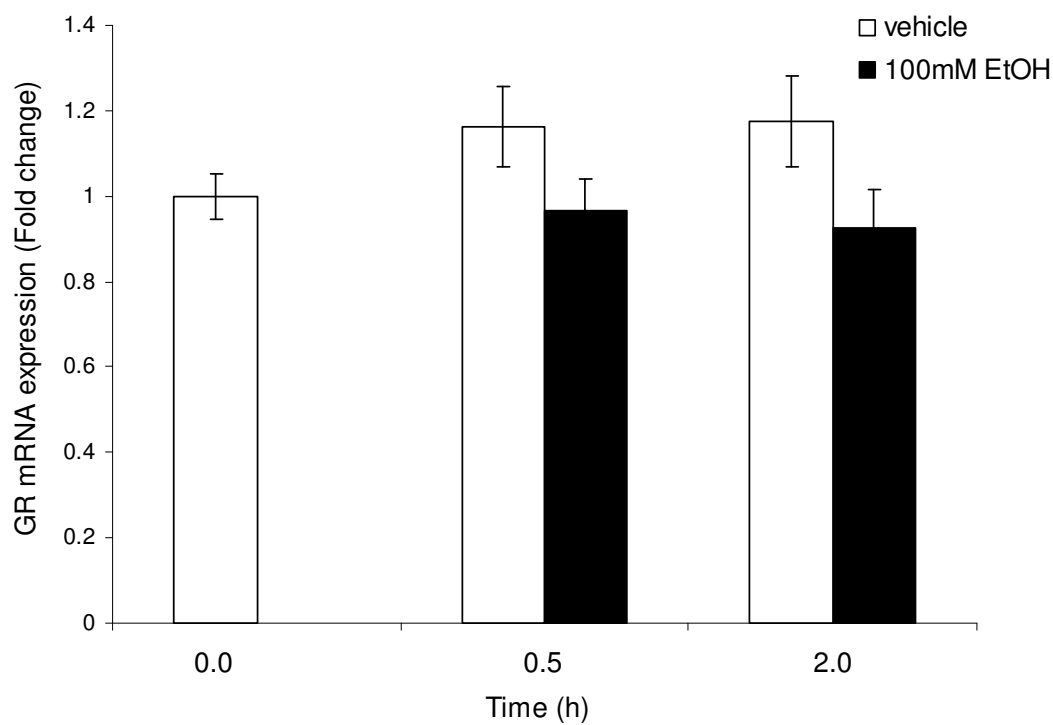

Fig 13. Effects of 0.5 h or 2.0 h EtOH treatment on the GR mRNA expression in IVB cell line. GR mRNA expression in IVB cell was measured after treatment with 100 mM EtOH for 0.5 or 2.0 h or vehicle. Data expressed as fold change in GR mRNA expression calculated according to the standard $\Delta\Delta\text{Ct}$ method.

EtOH increased CRH promoter activity at 2.0 h time point at all concentrations tested

The results obtained from initial experiments in Figure 12 demonstrated that EtOH alters CRH promoter activity. The concentration used in those experiments (100 mM) was based on previously published studies that used EtOH treatment in a cell culture model system however, the physiological relevance of this high concentration is questionable given that the blood alcohol level corresponding to the legal limit for driving (0.08%) is equivalent to about 25 mM (Pickering, Wicher et al.; Blevins, Mirshahi et al. 1997; McAlhany, Miranda et al. 1999; Li, Kang et al. 2005; Druse, Tajuddin et al. 2006; Lee, Tajuddin et al. 2009). Therefore, we tested CRH promoter activity in the presence of varying concentrations of EtOH in order to establish the minimal effective dose. The highest concentration of EtOH (100 mM) increased CRH promoter activity to the same degree following 2.0 h of EtOH treatment as observed in the previous time course experiments (Figs. 12A and 14). Surprisingly however, EtOH significantly increased CRH promoter activity at all of the lower concentrations we tested compared to vehicle treated control ($F(4,45) = 2.665$, $p=0.044$, $N = 6$, Fig 14). Also, there was no dose response observed, suggesting that lowest 12.5 mM concentration of EtOH is sufficient to elicit a maximal response of CRH promoter activity. Thus, for all subsequent studies the 12.5 mM concentration of EtOH was used in order to be consistent with concentrations that were more physiologically relevant.

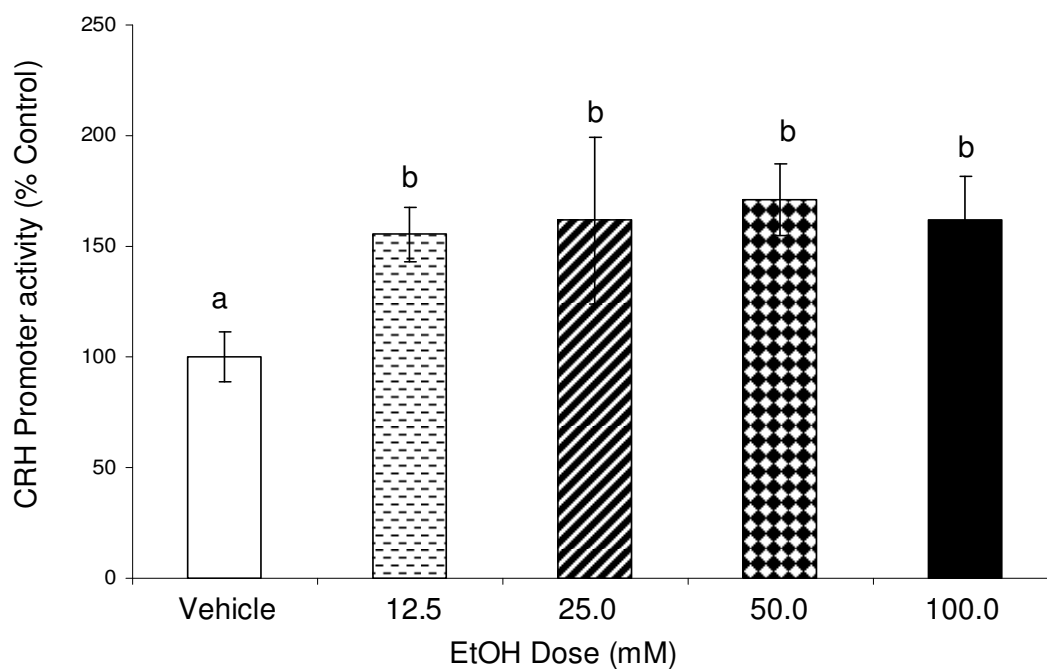

Fig 14. Effects of 2.0 h EtOH treatment with different concentrations of EtOH on CRH promoter activity. CRH-luciferase activity was measured in IVB cell line after treatment with 12.5, 25.0, 50.0 and 100 mM EtOH for 2.0 h or media alone. Data expressed as % change in luciferase activity from vehicle treated control. Dissimilar letters indicate statistically significant difference between treatment groups. More specifically, a is significantly different from b ($P < 0.05$).

Validation of CRH promoter deletion mutants with forskolin treatment.

To verify specific sites of EtOH action at the level of the CRH promoter, we sequentially deleted GR binding sites that are found within nGRE (see diagram in Fig 15 and Chapter 7 General Methods section for detailed description of methods used). In addition, we deleted a cAMP response element (CRE) site which is required for increasing CRH promoter activity (Liu, Kamitakahara et al. 2008). The CRE site has been implicated in EtOH effects at the CRH promoter in studies that showed that 25 mM EtOH treatment exerted a biphasic effect on the CRH promoter (a decrease at 0.5 h and an increase at 2.0 h) and that the forskolin induced increase in CRH promoter activity was decreased by EtOH treatment (Li, Kang et al. 2005).

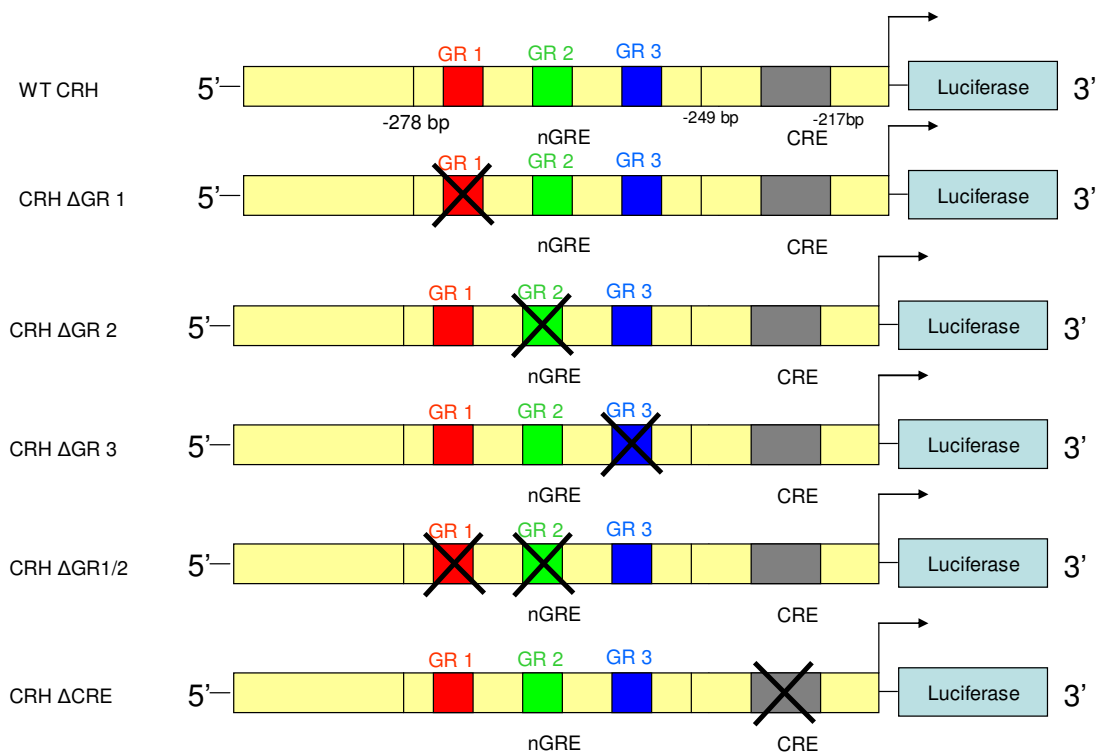

Fig 15. Schematic representation of the CRH promoter deletions used in these experiments. Diagrams depict specific portions of the nGRE site deleted within this site that is located between -249 and -278 bp upstream from the transcription initiation site (arrow) on the CRH promoter and the CRE site deletion that is located -217 bp upstream from the transcription site.

Initially, in order to test validity of these mutants generated, cells transfected with the WT or mutated CRH promoter were treated with 25 mM forskolin for 6.0 h and the promoter activity was measured using dual luciferase assay (see Chapter 7 General Methods section for detailed description of methods used). Forskolin is a potent activator of the CRH promoter by increasing cAMP levels and affecting signaling at the CRE site. As expected, forskolin treatment significantly increased CRH promoter activity in all CRH promoter constructs used except for the construct in which the CRE regulatory site was deleted (N = 3, Fig. 16). These data indicate that the CRH promoter manipulations did not render the promoter inactive and the constructs were responding to forskolin stimulation as expected.

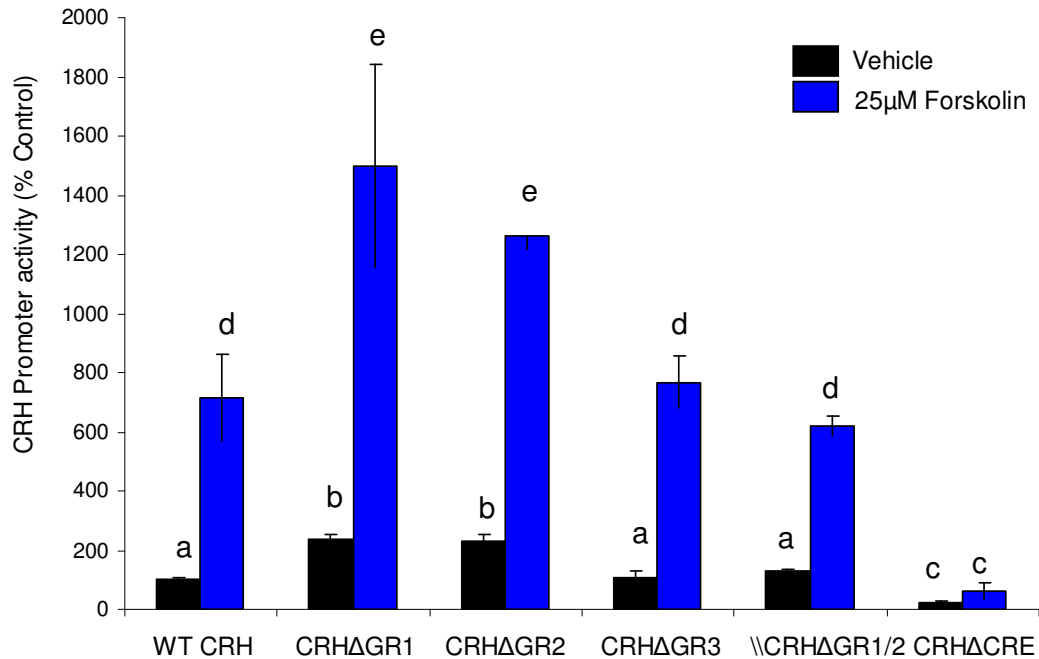

Fig 16. Effects of Forskolin treatment on WT and mutated CRH promoter activity.

Luciferase activity was measured in IVB cell line after treatment with 25 µM Forskolin for 6.0h (blue) or vehicle (black) in WT CRH promoter or in a promoter lacking above described regulatory sites. Data expressed as % change in luciferase activity of vehicle treated control. Dissimilar letters indicate statistically significant difference between groups. For example, a is significantly different from b, c, d, and e and so on ($P < 0.05$).

Basal activity of the CRH promoter was changed after specific deletions.

One-way ANOVA indicated that the mutations had a significant effect on basal (after vehicle treatment) CRH promoter activity ($F(5, 39) = 28.118$, $p < 0.001$, $N = 6$, Fig 16 black bars). Deletion of GR binding site 1 and 2 (CRH Δ GR1 and CRH Δ GR2) significantly increased basal CRH promoter activity ($p < 0.001$, Fig 15 black bars) and CRE site deletion (CRH Δ CRE) significantly decreased basal CRH promoter activity (Fig. 16 black bars, $p = 0.023$) as compared to vehicle treated promoter constructs.

Deletion of GR binding sites within nGRE abolished alcohol induced increase in CRH promoter activity at 2.0 h time point but did not prevent EtOH-induced decrease at 0.5 h

In order to investigate possible mechanisms involved in EtOH induced changes in CRH promoter activity, time course experiments with all the CRH deletion mutants described above were performed (see Chapter 7 General Methods section for detailed description of methods used). For the summary of results see Table 1.

Similar to the 100 mM dose, 12.5 mM EtOH treatment induced biphasic effects on the WT CRH promoter activity. These effects were altered in various CRH promoter mutants. More specifically, one way ANOVA revealed an effect of this EtOH treatment on CRH promoter activity ($F(4,36)=7.619$, $p < 0.001$) and post hoc tests showed that at 0.5 h there was a significant decrease ($p < 0.001$) and at 2.0 h there was a significant increase ($p = 0.023$) in CRH promoter activity due to

12.5 mM EtOH treatment as compared to vehicle treated controls (Fig.17A). The same effects were evident with 100 mM EtOH treatment. These results indicate that regardless of the dose tested, EtOH exerted biphasic effects on CRH promoter activity.

GR 1 and 2 deletions did not alter EtOH induced decreases in promoter activity but abolished an increase at 2.0 h. Notably, in these mutants EtOH treatment for 4.0 h increased the promoter activity. In the CRH Δ GR1 mutant, one way ANOVA showed an effect of EtOH treatment ($F(4,31)=8.144$, $p<0.001$) and post hoc analysis showed that at 0.5 and 1.0 h time point there was a significant decrease in promoter activity ($p=0.003$ and 0.004 , respectively, Fig 17B), an increase in CRH promoter activity was abolished at a 2.0 h time point but it was present at 4.0 h after 12.5 mM EtOH treatment ($p=0.015$). A similar trend was observed in the CRH Δ GR2 mutant. One way ANOVA showed an effect of EtOH treatment ($F(4,30)=4.826$, $p<0.001$) and post hoc tests revealed that at 1.0 h post EtOH treatment there was a significant decrease in the promoter activity (Fig 17C, $p=0.024$). An increase was abolished at 2.0 h but present at 4.0 h time point (Fig 17C, $p=0.002$) as compared to vehicle treated control.

A different pattern of responses was observed in the CRH Δ GR3 mutant. Even though one way ANOVA showed an effect of EtOH treatment on the CRH promoter ($F(4,37)=3.465$, $p=0.017$), in this mutant, EtOH induced changes in CRH promoter activity relative to the vehicle treated group were abolished (Fig. 17E). In this mutant, CRH promoter activity was significantly increased at the 4.0 h time point as compare to the 0.5 and 2.0 h time point ($p=0.018$ and $p=0.023$,

respectively). These data indicate that even though the CRH Δ GR3 mutant still exhibits dynamic changes after EtOH treatment, EtOH induced decrease and increase in CRH promoter activity relative to vehicle treatment were abolished. These data show that this site is important for EtOH modulation of the CRH promoter, especially for a decrease in the promoter activity.

The time course data in a CRH Δ GR1/2 mutant further supports the role of the GR binding site 3 in an EtOH induced decrease in CRH promoter activity. In this mutant, having only GR binding site 3 site of the nGRE intact, a decrease in CRH promoter activity was still present (Fig. 17D). One way ANOVA revealed that 12.5 mM EtOH treatment had a significant effect on CRH promoter activity in this mutant ($F(4,29)=3.108$, $p=0.03$). Post hoc analysis showed that at 0.5 h post EtOH treatment CRH promoter activity was significantly decreased as compared to vehicle treated control ($p=0.01$). An increase in the promoter activity in this mutant was completely abolished.

Interestingly, even though basal promoter activity was significantly decreased, in the CRH Δ CRE mutant, a slight decrease in the promoter activity was still observed at the 0.5 h time point (Fig 17F). One way ANOVA showed that EtOH exerted a significant effect on CRH promoter activity in this mutant ($F(4,19)=2.897$, $p=0.05$). Post hoc analysis showed that EtOH significantly decreased the promoter activity at 0.5 h time point ($p=0.046$) but completely abolished an increase in the promoter activity at the later time points.

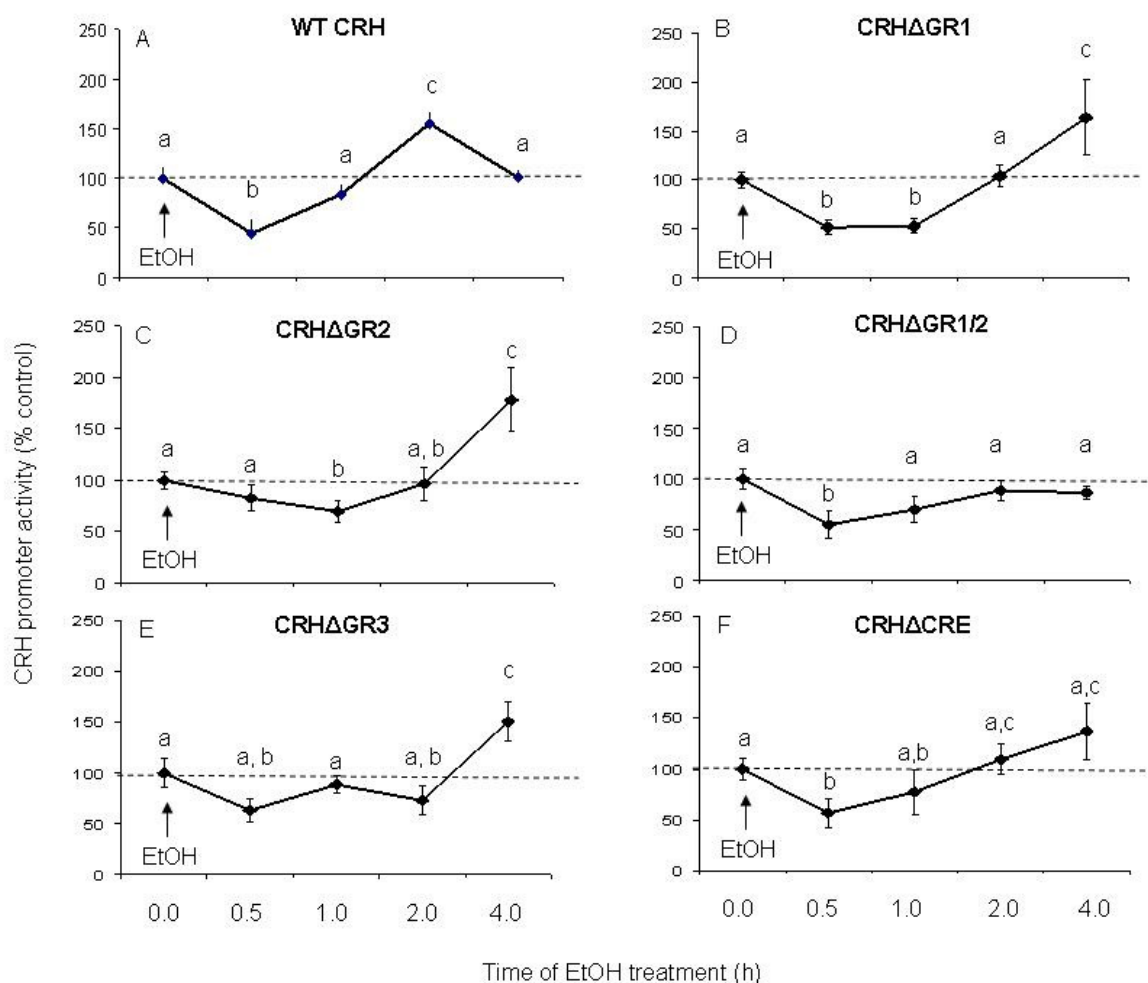

Fig 17. Effects of EtOH treatment on WT and mutated CRH promoter reactivity. Luciferase activity was measured in IVB cell line after treatment with 12.5 mM EtOH for 0.5, 1.0, 2.0 or 4.0 h or vehicle in A) WT CRH promoter, B) promoter lacking GR binding site 1 (CRH Δ GR1), C) GR binding site 2 (CRH Δ GR2), D) GR binding site 1 and 2 (CRH Δ GR1/2); E) GR binding site 3 (CRH Δ GR3), or F) CRE site (CRH Δ CRE). Data expressed as % change in luciferase activity from vehicle treated control. Dissimilar letters indicate statistically significant difference between groups. More specifically a is significantly different from b and c; ab is the not different from a or b but is different from c and so on ($P < 0.05$).

SUMMARY: Effects of alcohol on CRH promoter activity *in vitro*

- 12.5 and 100 mM EtOH ↓ CRH promoter activity at 0.5 h
- 12.5 and 100 mM EtOH ↑ CRH promoter activity at 2.0 h
- An increase in the promoter activity due to EtOH is dependant on the nGRE and CRE sites

CRH Promoter Construct	Basal activity of the promoter (vehicle) relative to WT promoter activity (100%)	Promoter activity at 0.5 h relative to basal promoter activity	Promoter activity at 1.0 h relative to basal promoter activity	Promoter activity at 2.0 h relative to basal promoter activity	Promoter activity at 0.4 h relative to basal promoter activity
WT CRH	100%	↓	-	↑	-
CRHΔGR1	↑	↓	↓	-	↑
CRHΔGR2	↑	-	↓	-	↑
CRHΔGR3	-	-	-	-	-
CRHΔGR1/2	-	↓	-	-	-
CRHΔCRE	↓	↓	-	-	-

Table 1. Summary of EtOH induced effects in different CRH promoter constructs, Arrows indicate relative relationships in the promoter activity as compared to vehicle treated construct, red = increase and green = decrease. Basal activity of different mutants is compared to activity of the WT vehicle treated CRH promoter.

Discussion

The goal of this study was to investigate *in vitro* the molecular mechanisms involved in alcohol induced increase in the CRH gene expression observed previously in the PVN of male rats. We tested the hypothesis that alcohol increases CRH mRNA expression in the PVN by directly interfering with negative glucocorticoid feedback at the level of the CRH promoter. Our data clearly show that *in vitro* EtOH treatment directly influences CRH promoter activity and that an increase in the promoter activity observed at 2.0 h is mediated via EtOH-GR signaling interaction at the nGRE site and its possible interactions with the signaling at the CRE site of the CRH promoter.

When activated GRs interact with nGRE to recruit specific coregulators, they also prevent signaling at the CRE site of the CRH promoter by CREB, decreasing the activity of this promoter and its transcription. It has been shown that interaction between the nGRE and CRE sites is required for normal glucocorticoid mediated decrease in CRH promoter activity (King, Smith et al. 2002), Fig 17A). Based on my data, I propose that in the presence of EtOH, GR-CRH DNA interaction at the nGRE site is blocked allowing for free access of phosphorylated CREB (pCREB) to the CRE site and activation of CRH promoter (Fig 17B) which will then result in increased gene transcription and CRH mRNA expression that has been previously observed *in vivo* (Rivier and Lee 1996; Ogilvie, Lee et al. 1997; Ogilvie, Lee et al. 1998; Li, Kang et al. 2005; Przybycien-Szymanska, Rao et al. 2009).

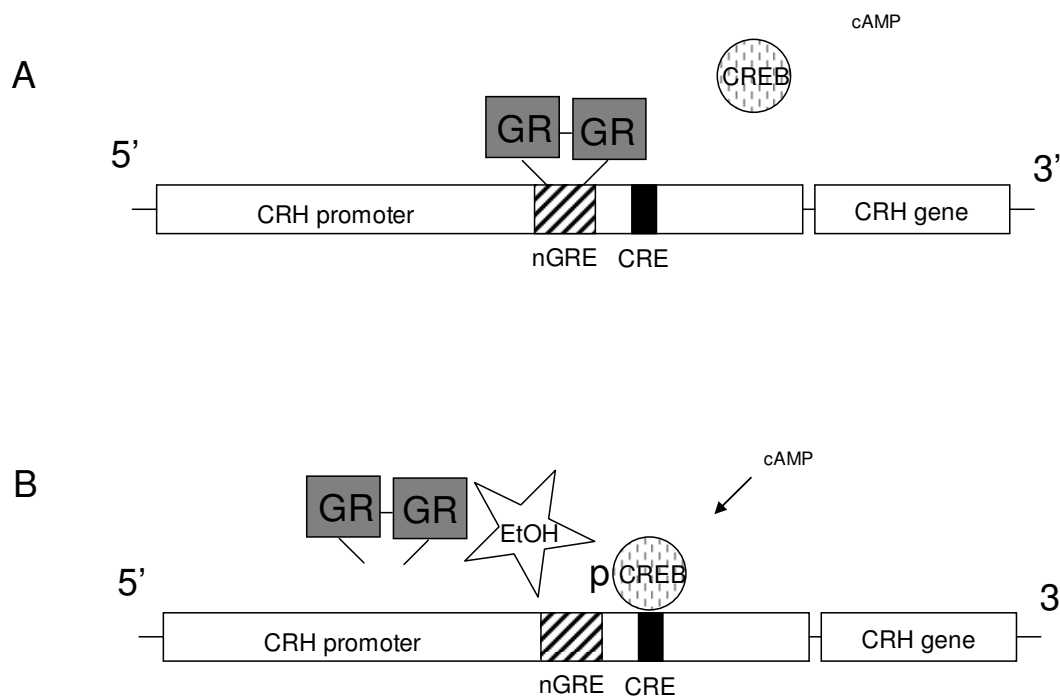

Fig. 18. Schematic model describing EtOH effects on the CRH promoter. A. In the absence of EtOH when activated GRs interact with nGRE to recruit specific coregulators (not depicted in this diagram), they also prevent signaling at the CRE site of the CRH promoter by CREB thereby decreasing the activity of this promoter and its gene transcription. These interactions between the nGRE and CRE sites are required for glucocorticoid mediated decrease in CRH promoter activity. It is possible that at 0.5 h EtOH treatment this mechanism is enhanced through yet un identified mechanisms. B. If EtOH treatment is prolonged, GR-CRH DNA interaction at the nGRE site is blocked allowing for free access of phosphorylated CREB (pCREB) to the CRE site and activation of the CRH promoter which will then result in increased gene transcription.

This conclusion is substantiated but the following data: 1) EtOH directly modulated CRH promoter activity in PVN derived neuronal cell line; 2) GR antagonist (RU486) abolished EtOH induced increase in CRH promoter activity observed at 2.0 h and 3) deletion of either of the specific GR binding sites within the nGRE site prevented EtOH induced increase in the promoter activity. These data support my hypothesis that alcohol modulates CRH mRNA expression in the PVN by directly interfering with negative glucocorticoid feedback exerted at the level of the CRH promoter. A direct effect of EtOH at the CRH promoter is further substantiated by data showing no changes in GR expression upon EtOH treatment in IVB cells.

This conclusion is consistent with previous *in vivo* reports showing that chronic EtOH treatment and withdrawal modulated GRE-DNA binding in rat cortex and hippocampus. Chronic alcohol diet (15 days) decreased GRE- DNA binding in the cortex and hippocampus as measured by chromatin immunoprecipitation assay (ChIP) but 24.0 h withdrawal returned GRE-DNA binding levels back to basal levels only in hippocampus; in the cortex GRE-DNA binding levels remained decreased (Roy, Mittal et al. 2002). Our *in vitro* data show that deletion of portions of nGRE site on the CRH promoter and GR antagonist treatment abolished EtOH induced changes in the promoter activity. Based on these data, it is likely that alcohol affects GR protein binding at the GRE site of the CRH promoter but additional experiments verifying GRE-DNA binding of GR at the CRH promoter in the presence and absence of EtOH need to be performed in order to further verify this hypothesis.

Contrary to the results obtained by Roy, et al., we did not observe any EtOH-mediated changes in GR mRNA expression. One possibility is that GR protein levels change with chronic, as opposed to acute, EtOH treatment, although Spencer and McEwan (1990) also noted that there were no changes in cytosolic fractions of mineralocorticoid receptor (MR) or GR following chronic EtOH treatment in the brains of adult rats (Spencer and McEwen 1990). By contrast, Little et al., (2008) showed that chronic EtOH treatment (28 week, liquid diet) and 2 week withdrawal increased nuclear GR protein but did not change the cytosolic GR protein levels in the prefrontal cortex of male C57BL mice (Little, Croft et al. 2008). In our study we measured GR mRNA and not protein due to the short time course of EtOH treatment, but the above cited studies raise the possibility that EtOH might directly target nuclear GR protein for degradation or alter translational processing of GR mRNA.

There are several other possibilities that might explain our divergent results. First, it is possible that the reason why there were no changes in the GR is because we used an immortalized cell line instead of primary cells. Second, in previous reports investigators looked at the protein levels when we measured mRNA expression. Therefore, it is possible that EtOH could affect protein stability instead of transcriptional activity of the gene. Further experiments need to be performed in primary neurons or in neuronal cell lines to verify if changes in the GR expression in the PVN or in PVN derived cell lines play a role in EtOH induced increase in CRH promoter activity and increase in CRH mRNA after binge EtOH exposure.

Deletion of either GR binding site of the nGRE regulatory region of the CRH promoter abolished EtOH induced increase in CRH promoter activity at a 2.0 h time point. Notably, in CRH Δ GR1 and CRH Δ GR2 mutants an increase in CRH promoter activity was present at 4.0 h time point post EtOH treatment indicating that when only one of the two GR binding sites is present, EtOH can still activate the promoter but it takes longer for it to do so. Deletion of both sites abolished the EtOH induced increase in the promoter activity completely indicating that these sites are important for EtOH effects. Deletion of the GR binding site 3 abolished EtOH induced increase in the promoter activity at 2.0 h as well and this effect was still not present at the 4.0 h time point. Together, these data indicate that at least two GR binding sites (GR 1 or 2 plus GR 3) are required for EtOH induced increase in promoter activity. Further studies need to be performed in order to elucidate more closely interactions between these GR binding sites on the CRH promoter that are involved in EtOH induced effects. Nevertheless, these data clearly show that EtOH disrupts normal glucocorticoid negative feedback exerted at the promoter level.

Deletion of the CRE site eliminated EtOH induced increase in the promoter activity at 2.0 h time point but it also decreased basal CRH promoter activity and prevented forskolin induced activation of the promoter activity but did not abolish EtOH induced decrease in CRH promoter activity at 0.5 h.. Previous reports showed that in a rat glioma hybrid NG108-15 cell line, alcohol decreased forskolin induced increase in CRH promoter activity (Li, Kang et al. 2005) making it likely that the CRE site of the promoter is responsible for alcohol effects on the

CRH promoter. It is well known that cAMP signaling, CREB binding and coactivator recruitment to the CRH promoter is required for transcriptional activation of the CRH (Liu, Kamitakahara et al. 2008). Therefore, it is not surprising that when the CRE site is deleted, the CRH promoter cannot be activated, even in the presence of the potent cAMP stimulator, forskolin. Interaction of CRE site signaling with the effects exerted at the nGRE site were not investigated in the Li et al., study, but since nGRE and its interaction with the CRE site in the presence of glucocorticoids is required for inhibition of CRH promoter activity (Malkoski and Dorin 1999; King, Smith et al. 2002), it is likely that alcohol interferes with GR signaling at the level of the nGRE site of the CRH promoter and the interaction between nGRE site and the signaling at the CRE site is required for alcohol effects.

These data suggest that the observed EtOH-induced decrease in CRH promoter activity does not involve the GR binding site 1 or 2 or the CRE site but requires GR binding site 3. This further supports my conclusion that EtOH interferes with GR signaling at the nGRE site to dysregulate the promoter activity. Based on my data, it appears that at an early time point (0.5 h), normal negative feedback exerted by glucocorticoids is still present and longer EtOH treatment time is required for EtOH induced dysregulation of this feedback and an increase in the promoter activity. Notably, these data indicate GR binding site 3 as being extremely important for this negative feedback. EtOH-induced decrease in the promoter activity was completely abolished only when this site was deleted. These data are consistent with our previous *in vivo* data showing that

longer/repeated EtOH exposure, i.e. binge EtOH exposure, is required for EtOH induced dysregulation of the HPA axis. Together, data presented herein clearly show that EtOH effects are mediated through nGRE site-EtOH interactions at the level of the CRH promoter and longer periods of EtOH treatments are required for dysregulation of normal glucocorticoid negative feedback.

One may argue that an increase in CRH promoter activity at 2.0 h is a result of compensatory mechanisms being activated in the cells due to alcohol induced cell death at that may have occurred at 0.5 h when a decrease in promoter activity was observed. This explanation is highly unlikely due to following reasons: 1) there was no decrease in cell viability at 0.5 h as measured by MTT assay and 2) an increase in the promoter activity at 2.0 h time point exceeded basal levels of the activity of the promoter which would be highly unlikely to happen if cell death was occurring

100 mM EtOH treatment did not induce cell death at any time point tested, instead, it increased mitochondrial activity at 4.0 h as measured by MTT toxicology assay in which increased absorbance indicates increased mitochondrial dehydrogenases activity. This result could be potentially an effect of increased mitochondrial activity due to EtOH-induced oxidative stress in cells. This conclusion is substantiated by previous reports showing a time course of events in primary cortical neurons after EtOH exposure (Ramachandran, Watts et al. 2003). In this report researchers showed that 5 min after 4.0 mg/ml EtOH treatment, there is an increase in the amount of reactive oxygen species, followed by an increase in mitochondrial 4-hydroxynonenal (HNE) at 1.0 h,

followed by an increase in cytochrome c release at 2.0 h and increase in caspase 3 activation at 12.0 h. This sequence of events results in DNA fragmentation and decrease in cell number that starts at 12.0 h of EtOH exposure (Ramachandran, Watts et al. 2003). This proposed time line suggests that an increased mitochondrial activity at 4.0 h in our system could be a result of an initiation of oxidative stress induced cell death but it was too early for cell death to occur. If alcohol treatment was longer than 4.0 h, we could possibly observe a decrease in cell viability which would indicate cell death. Nevertheless, cell death was not observed at any time point in our studies and could not explain the observed decrease in CRH promoter activity at 0.5 h time point.

Overall, results presented in this study show that in a neuronal cell line derived from the PVN, alcohol increases CRH promoter activity by interfering with GR signaling at the nGRE site of the promoter. This may explain a potential mechanism by which EtOH treatment *in vivo* increases the CRH mRNA levels in the PVN. Although further investigation is required to assess alcohol effects on upstream molecular targets that result in increased promoter activity. These data for the first time identify neuronal GR- CRH DNA system as a direct target for alcohol influence in the PVN.

CHAPTER FOUR

ROLE OF ESTRADIOL IN THE HYPOTHALAMO-PITUITARY-ADRENAL (HPA) AXIS RESPONSIVENESS OF PERI-PUBERTAL FEMALE RATS TO BINGE ALCOHOL EXPOSURE

Introduction

Alcohol abuse during adolescence is a fundamental health concern in the United States. According to the U.S. Department of Health and Human Services, 41% of teenagers have had their first drink by the age of 14. Underage drinkers typically adopt a “binge” pattern of alcohol consumption, defined by the National Institute on Alcohol Abuse and Alcoholism (NIAAA) as heavy, episodic drinking in which enough alcohol is consumed to bring the blood alcohol concentration above 0.08 % limit within that 2.0h period (White, Kraus et al. 2006). According to the Department of Health and Human Services survey performed in 2005, 2.0% of 12-13 year-old, 8.0% of 14-15 year-old, 19.7% of 16-17 year-old and 51% 18-20 year-old adolescents reported this pattern of drinking within a month preceding the survey. Overall, these statistics indicate that a significant percentage of the adolescent population consumes heavy doses of alcohol during this critical period of brain development which is called adolescence and is

marked by dendrite pruning, prefrontal cortex development, increases in white matter and formation of new neuronal connections (Woo, Pucak et al. 1997; Giedd, Blumenthal et al. 1999; Paus, Zijdenbos et al. 1999; Cunningham, Bhattacharyya et al. 2002; Sisk and Zehr 2005; Lenroot and Giedd 2006; Raymond, Kucherepa et al. 2006)

One system that undergoes extensive maturation during adolescence is the hypothalamo-pituitary-adrenal (HPA) axis (Romeo, Lee et al. 2004; Romeo, Bellani et al. 2006; Romeo and McEwen 2006; McCormick and Mathews 2007; Evuarherhe, Leggett et al. 2009; Evuarherhe, Leggett et al. 2009). Under normal physiological conditions, an acute stressor activates the HPA axis. Hypothalamic corticotrophin-releasing hormone (CRH) stimulates adrenocorticotrophic hormone (ACTH) release from the anterior pituitary which in turn, causes the release of adrenal glucocorticoids, cortisol in humans and corticosterone (CORT) in rodents. Arginine vasopressin (AVP) released from the parvocellular portion of the paraventricular nucleus of the hypothalamus (PVN) and is known to act synergistically with CRH to augment the release of ACTH and CORT and mediate stress and anxiety responses (Dickstein, DeBold et al. 1996; Wigger, Sanchez et al. 2004; Egashira, Tanoue et al. 2007). This sequence of events sets up a negative feedback system whereby increased circulating glucocorticoid levels serve to inhibit the additional release of hypothalamic CRH and AVP by inhibiting the activity of the promoter (Van, Spengler et al. 1990; Iwasaki, Oiso et al. 1997; Malkoski and Dorin 1999; Kim, Summer et al. 2001).

Several lines of evidence suggest that acute or chronic alcohol exposure might lead to increased displays of anxiety behavior. Correlative studies have demonstrated that over 50% of patients with alcohol dependency also have anxiety-related or depression-related psychiatric disorders (Conway, Compton et al. 2006), and these types of disorders are often associated with an abnormal stress response. Interestingly, women alcoholics have a higher incidence of clinically diagnosed anxiety disorders compared to men alcoholics (Zilberman, Tavares et al. 2003; Epstein, Fischer-Elber et al. 2007), possibly due to the inherent sex differences in the stress responses of the HPA axis (Becker, Monteggia et al. 2007; Handa, Zoeller et al. 2007).

Pubertal binge-alcohol exposure can alter the expression of both the CRH and the AVP mRNA in the PVN, a main region involved in modulating stress responses. We have shown previously that in peri-pubertal male rats, binge, but not acute EtOH exposure increased the expression of the CRH and AVP mRNA in the PVN but this effect was not observed in female peri-pubertal rats (Przybycien-Szymanska, Rao et al. 2009). In addition, in adult rats, even single exposure to alcohol at the dose of 3g/kg, significantly increased PVN expression of CRH and AVP mRNA but as observed in peri-pubertal rats, this effects was evident only in males. Together, these data clearly indicate that there is a sex difference in the responsiveness of the HPA axis to alcohol exposures and this sex difference becomes apparent during peri-pubertal development but the mechanisms behind these inherent sex differences in the responsive of female HPA axis to alcohol exposure remain unknown.

In this study, the role of 17β -estradiol (E_2) in the responsiveness of peri-pubertal females to binge pattern EtOH exposure as well as the role of E_2 to alcohol effects *in vitro* were investigated. I hypothesized that 1) in ovariectomized females E_2 replacement will prevent alcohol induced changes in the CRH and AVP mRNA levels in the PVN that will be evident in Ch-treated group and 2) that in a cell culture, E_2 treatment will prevent an increase in the CRH promoter activity observed previously in the CRH promoter after alcohol treatment. We showed here that 1) in E_2 -treated females, binge EtOH exposure did not cause changes in the CRH and AVP mRNA in the PVN and that the increase in circulating CORT level after binge EtOH exposure was lower compared to an increase in plasma CORT levels after acute EtOH exposure (habituation effects), 2) in Ch-treated females, binge EtOH exposure decreased the CRH and AVP mRNA levels in the PVN and prevented habituation effect after binge EtOH exposure and 3) that in a neuronal cell line E_2 treatment prevented EtOH induced increase in CRH promoter activity.

Results

General Approach

In order to investigate a role of estradiol (E_2) in sex differences observed after EtOH exposure during puberty on stress responsiveness of the HPA axis during this time period, peri-pubertal ovariectomized on PND 26 female rats that were replaced either with Cholesterol (Ch) or 17β -estradiol (E_2) were treated either with saline, acute EtOH or binge EtOH exposure between PND 37 and 44

(see Fig 2 and Table 2 for binge EtOH exposure paradigm Fig 2 and experimental design Table 2). On the last day of treatments (PND 44), 1.0 h after the last EtOH administration, animals were sacrificed and brains and trunk blood were collected. Plasma was isolated and used for further hormone and BAC measurements. Brains were rapidly frozen, sectioned on a freezing microtome and PVN and SON were microdissected for CRH and AVP mRNA measurements using qRT-PCR.

In addition, the effect of E_2 on EtOH induced changes in CRH promoter activity was investigated in a neuronal cell line (IVB) derived from the PVN. Cells were transfected with CRH promoter-luciferase construct and 8.0 h after transfections, cells were pre-treated with 10 nM E_2 for 16.0 h. After 16.0 h pre-treatment period, cells were incubated with 10 nM E_2 and 100 mM EtOH for 2.0 h and then CRH promoter activity was measured using dual luciferase assay (see Chapter 7, General Methods section for detailed description of methods used in this chapter).

Body weight differences and E_2 levels after alcohol treatments in ovariectomized Ch- or E_2 - treated female rats

On PND 26, females were bilaterally ovariectomized and replaced with silastic capsules containing either 17β -estradiol (E_2) or cholesterol (Ch). On PND 37, both E_2 -treated and Ch-treated animals were randomly assigned to either 1) saline-treated (N = 8/group), 2) acute EtOH treated (N=8/group) or 3) binge EtOH

treated (N = 8/group, 3g/kg/day) groups (see Table 2 and Chapter 7 General Methods section for detailed description).

Experimental design 1

PND 26	PND 37-44
OVX + Chol (n=24)	Saline (n=8)
	Acute EtOH (n=8)
	Binge EtOH (n=8)
OVX + 17 β -Estradiol (n=24)	Saline (n=8)
	Acute EtOH (n=8)
	Binge EtOH (n=8)

Saline = 8 days ip 0.9% saline

Acute EtOH = 7 days ip saline + 1 day 3g/kg EtOH

Binge EtOH = 3 days ip 3g/kg EtOH + 2 days saline + 3 days ip 3g/kg EtOH

Table 2. *Schematic representation of treatment groups used.* Pre-pubertal females (PND 26) were bilaterally ovariectomized and replaced with 1.0 mm silastic capsules containing cholesterol (Ch) or 17 β -estradiol (E₂). Starting on PND 37, animals received one of the three treatments; saline, acute EtOH or binge EtOH.

Body weight measurements were obtained every other day during the duration of treatments. Repeated measures mixed ANOVA revealed that there was no main effect of EtOH treatment on body weight gain ($F(2,44) = 0.252$; $p=0.388$) but that there was a main effect of age ($F(1,44)= 9.9$. $p = 0.003$). In addition, there were no between subject interactions on weight gain in these groups ($F(2,44)=0.267$, $p=0.767$). On the other hand, there was hormone by age interaction on weight gain between groups ($F(1,45)=33.362$, $p<0.001$). These data show that within E_2 -treated group, animals gained weight slower compared to animals within Ch-treated group (Fig. 19), Even though E_2 treatment had an effect on body weight gain, EtOH did not cause animals to lose weight. As expected, in Ch-treated females lack of E_2 in the system resulted in increased body mass as compared to E_2 -treated females (Fig 19B) indicating that implantation of E_2 containing capsules was effective in our animals and raised plasma E_2 levels.

As reported by Dr. Pau from Oregon National Primate Research Center/Oregon Health Science University Endocrine Technology and Support Laboratory, E_2 levels in E_2 -replaced ovariectomized females were 65 ± 7.3 pg/ml and there were no differences in plasma E_2 levels between different EtOH treatment groups ($F(2,20)=2.929$, $p=0.077$). These data, together with body weight data, indicate that E_2 replacement via silastic capsules was effective in these experiments and raised plasma E_2 levels to expected values.

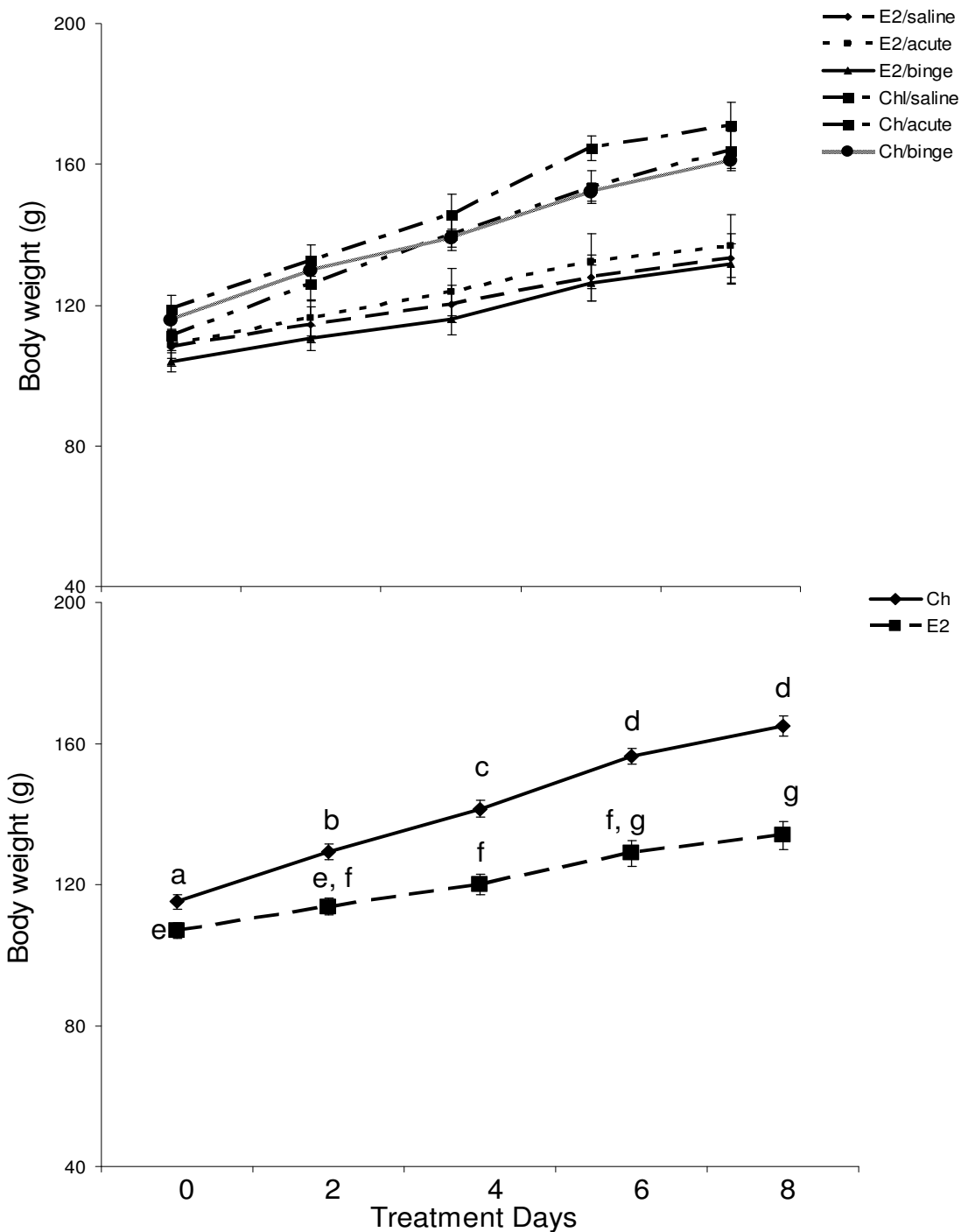

Fig 19. Effects of ethanol treatment on body weight of ovariectomized females replaced either with Ch or E_2 during pubertal development. Representative mean body weights of animals in all treatments groups (A) and combined treatments groups within Ch and E_2 females (B) treated with daily IP injections of saline, saline + one day EtOH (acute), or

binge EtOH paradigm. Dissimilar letter indicate statistically significant difference. More specifically a is different from b, c, d, e, f, fg, and g; ef is different from a, b, c, d, and g ($p < 0.05$).

Blood alcohol concentrations (BAC) in Ch- or E₂- treated ovariectomized females.

1.0 h after the last EtOH treatment, BAC were measured using commercially available kit (Pointe Scientific) (see Chapter 7 General Methods section for details). Two-way ANOVA showed that there was no main effect of hormone treatment ($F(2,38) = 1.595$; $p = 0.516$) and that there was a main effect of EtOH treatment ($F(2,38) = 60.368$, $p < 0.001$) on BAC in these experiments. There was no interaction between these two factors ($F(4,38) = 1.678$; $p = 0.175$). On average, EtOH exposure resulted in BAC of 257.09 ± 19.97 mg/dl and 275.77 ± 22.94 (Fig 20) in E₂-treated and Ch-treated females, respectively. More specifically, acute (single dose) EtOH exposure resulted in BAC of 252.25 ± 36.57 and 244.65 ± 28.85 in E₂- and Ch-treated females, respectively and in both cases the values were significantly different from BAC in saline group (below the limit of detection, $p < 0.001$). Binge EtOH exposure resulted in BAC of 221.94 ± 17.52 and 306.89 ± 33.84 in E₂- and Ch-treated females, respectively and they both were significantly higher compared to BAC in saline treated controls (below the limit of detection, $p < 0.001$, Fig 20). These values are consistent with the defined BAC threshold of binge drinking.

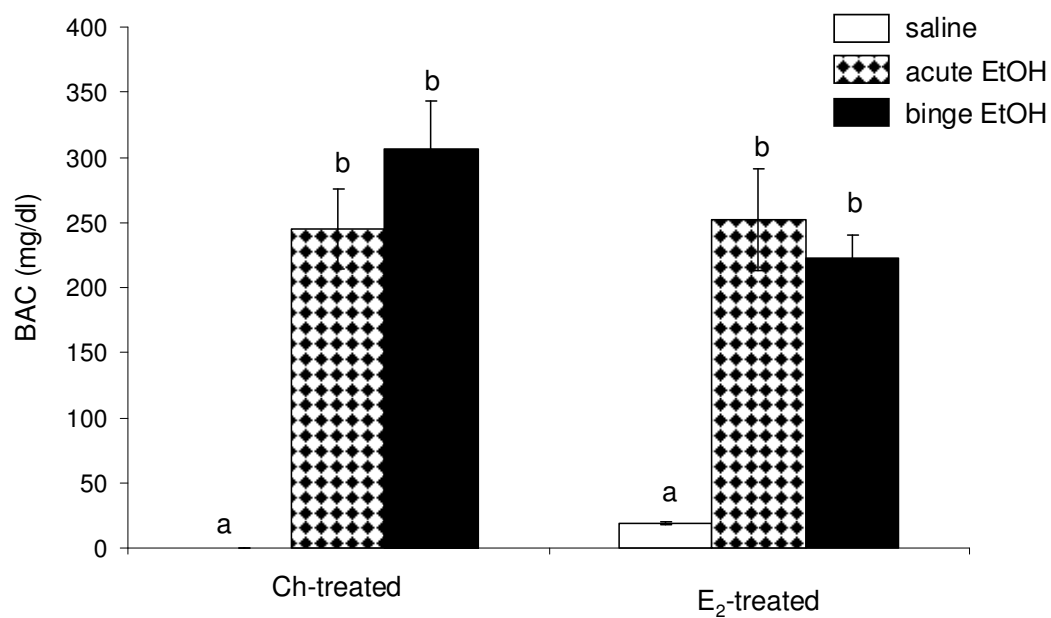

Fig 20. Effects of EtOH treatments on blood alcohol levels in ovariectomized female rats. Blood alcohol concentrations (BAC) 1.0 h post-injection in ovariectomized females replaced either with Ch or E₂ and then treated with saline, acute EtOH or binge EtOH. Data expressed as mean alcohol mg/dl. Dissimilar letter indicate statistically significant difference between groups. More specifically a is significantly different from b (P < 0.05).

Plasma ACTH and CORT levels after alcohol exposure in Ch- or E₂- treated ovariectomized (OVX) females rats

In order to investigate the effects of E₂ replacement on the effects of EtOH exposure during peri-puberty on circulating ACTH and CORT levels in OVX females, both plasma ACTH and CORT levels were measured using RIA (see Chapter 7 General Methods section for details). Overall two-way ANOVA revealed that there was a main effect of hormone treatment ($F(1,35) = 10.563$; $p=0.003$) and a main effect of EtOH treatment ($F(2,35) = 24.219$; $p<0.001$) on the plasma ACTH levels and that there was no interaction between the two factors (Fig 21A; $F(2,35) = 3.154$, $p = 0.055$). In Ch-treated females, both acute ($p<0.001$) and binge ($p=0.002$) EtOH exposures significantly increased plasma ACTH levels as compared to saline treated controls and there was no difference between plasma ACTH levels in acute EtOH group as compared to binge EtOH group (Fig 21A, $p=0.735$). Plasma ACTH levels in E₂-treated group showed a different pattern of responses to EtOH exposure. Notably, there was a significant increase in plasma ACTH levels after acute EtOH exposure ($p<0.001$) and no changes after binge EtOH exposure (Fig 21A, $p=0.15$) as compared to saline treated controls (Fig 21A). These data indicate a habituation effect that is absent in Ch-treated group. Plasma ACTH levels in binge EtOH group were not different as compared to saline treated group within this hormone treatment ($p=0.159$).

Analysis of plasma CORT levels revealed that there was no main effect of hormone treatment ($F(2,36) = 0.318$; $p=0.73$) and that there was a main effect of EtOH treatment ($F(2,36) = 27.834$; $p<0.001$) on the plasma CORT levels. There

was no interaction between the two factors (Fig 21B; $F(4, 36) = 2.235, p = 0.084$) (Fig 21B). In Ch-treated females, both acute ($p < 0.001$) and binge ($p < 0.001$) EtOH exposures significantly increased plasma CORT levels as compared to saline treated controls and there was no difference between plasma CORT levels in acute EtOH group as compared to binge EtOH group ($p = 0.547$). Plasma CORT levels in E_2 -treated group showed a different pattern of responses to EtOH exposure. There was a significant increase in plasma CORT levels after acute EtOH exposure ($p = 0.007$) and no changes after binge EtOH exposure ($p = 0.567$) as compared to saline treated controls (Fig 21B). These data further indicate that the habituation effect that is absent in Ch-treated group is present in E_2 -treated females. Lastly, as expected, based on studies performed in intact animals and based on known influence of E_2 on stress axis in females (Sencar-Cupovic and Milkovic 1976; Rivier 1993; Weiser and Handa 2009; Przybycien-Szymanska, Rao et al. 2010), basal (saline induced) plasma CORT levels were higher in E_2 -treated females as compared to Ch-treated females (Fig 21B, $p = 0.032$).

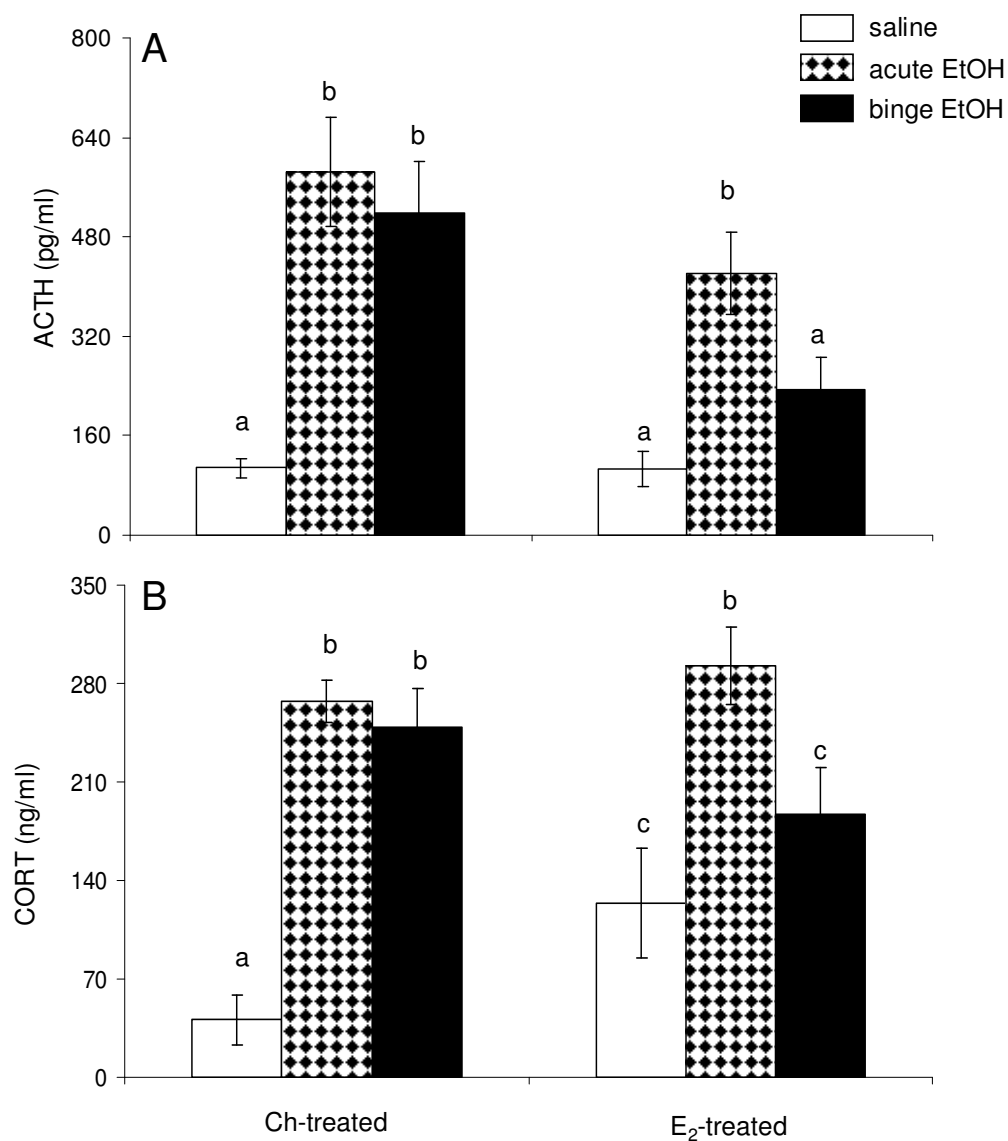

Fig 21. Effects of EtOH treatments on blood ACTH and CORT levels in ovariectomized female rats replaced with Ch or E₂. Plasma ACTH (A) and CORT (B) levels in ovariectomized females replaced either with Ch or E₂ 1.0 h after IP injection of saline, acute, or binge EtOH treatments.. Data expressed as mean ACTH and CORT ng/ml of blood. Dissimilar letters indicate statistically significant difference among groups. More specifically a is significantly different from b and c but not from a, and b is different from a and c but not b and so on (P < 0.05).

CRH and AVP mRNA expression in the PVN after alcohol treatments in CH- or E₂-treated ovariectomized (OVX) females.

In order to investigate the effects of E₂ replacement on the effects of EtOH exposure during peri-puberty on the expression of genes involved in stress and anxiety responses in OVX females, CRH and AVP mRNA were measured using qRT-PCR (see Chapter 7 General Methods section for details). Two-way ANOVA revealed that there was no main effect of hormone treatment on the expression of CRH mRNA ($F(1,40) = 0.0575$; $p=0.812$) (Fig 22A) or AVP mRNA ($F(1,40)=1.008$; $p=0.321$) (Fig 22B) in the PVN and that there was a main effect of EtOH treatment on the CRH mRNA expression ($F(2,40) = 5.397$, $p = 0.008$). There was no interactions between these two factors on the CRH mRNA expression ($F(2,40)=1.622$; $p=0.21$) or on the AVP mRNA expression ($F(2,40)=2.008$; $p=0.148$) in the PVN in peri-pubertal females. Post hoc analysis of the CRH and AVP mRNA expression in the PVN of Ch-treated females showed that binge EtOH exposure significantly decrease the CRH mRNA (Fig 22A, $p=0.03$) and AVP mRNA (Fig 22B, $p=0.028$) expression in these treatment groups but there were no differences within E₂-treated females.

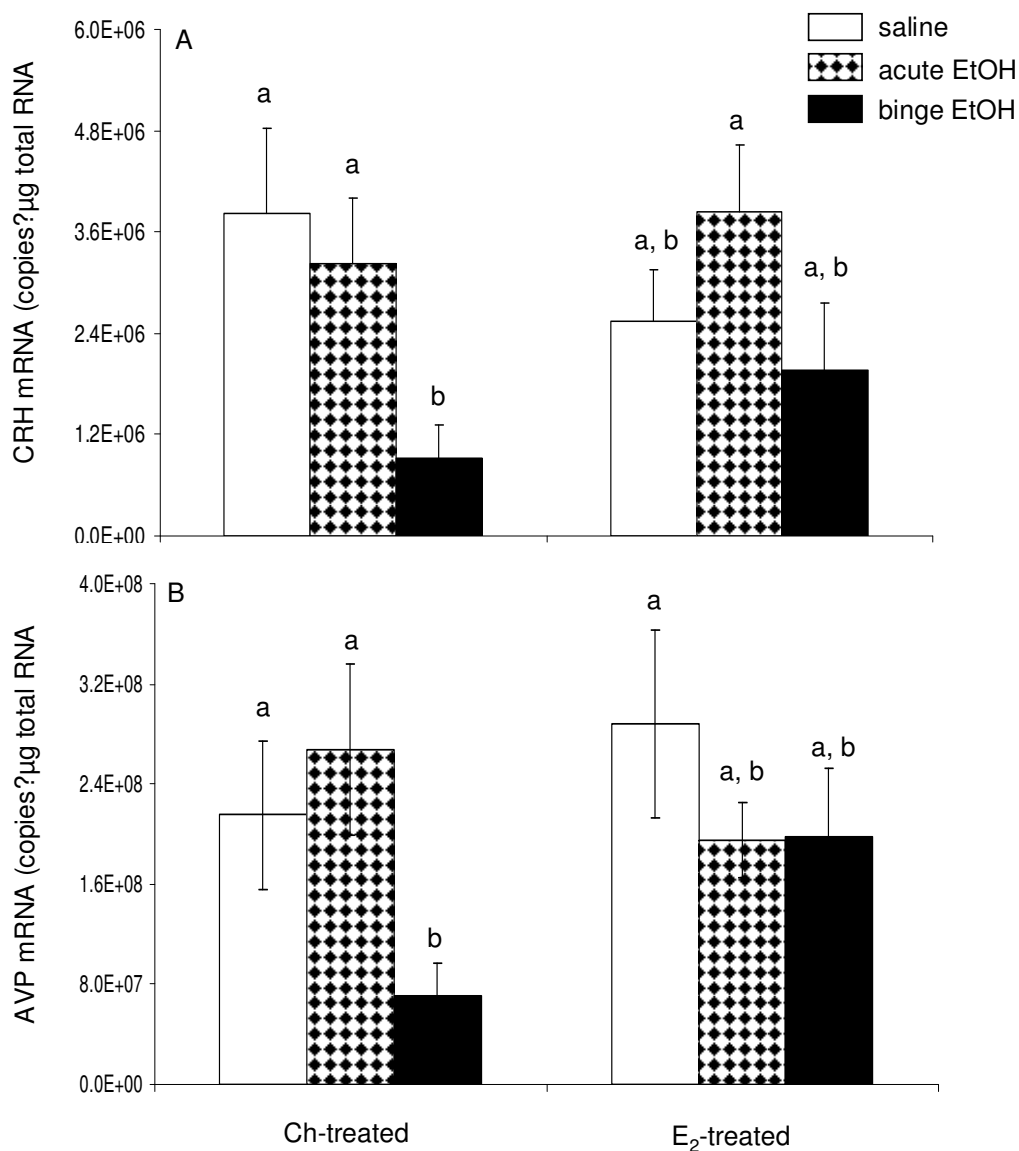

Fig 22. Effects of EtOH treatments on CRH and AVP gene expression in the PVN of ovariectomized female rats replaced with Ch or E₂. CRH (A) and AVP (B) mRNA expression in the PVN of peri-pubertal females replaced either with Ch or E₂ 1.0 h after treatment with either saline, acute, or binge EtOH. Data expressed as mRNA copies/μg total RNA. Dissimilar letters indicate statistically significant difference between groups. For example, a is significantly different from b but not ab and so on (P < 0.05).

CRH and AVP mRNA expression in the SON after alcohol treatments in Ch- or E₂-treated ovariectomized (OVX) females.

We have shown previously that in peri-pubertal male and female rats (Przybycien-Szymanska, Rao et al. 2009), EtOH does not change the AVP mRNA expression in the SON, a main region responsible for osmoregulation which indicated that the effects observed in all previous studies in the PVN were not due to diuretic effects of EtOH on the AVP containing neurons. In this study I also measured the AVP mRNA expression in the SON in order to verify the HPA axis specificity of EtOH effects using qRT-PCR. Contrary to what we observed in intact animals, there were changes associated with EtOH treated in the AVP mRNA expression in the SON. Two-way ANOVA revealed that there was a main effect of EtOH treatment ($F(2,39)=4.696$, $p=0.015$) and no main effects of hormone replacement ($F(1,39)=1.434$, $p=0.238$) on the AVP mRNA expression in the SON and that there was an interaction between the two factors analyzed ($F(2,39)=4.075$, $p=0.005$) (Fig. 23). Post-hoc tests showed that in E₂-treated females, there were no changes in the AVP mRNA expression ($p=0.907$); however, in the Ch-treated group binge EtOH treatment significantly decreased the AVP mRNA levels as compared to saline controls ($p<0.001$) and acute EtOH group ($p = 0.003$). There were no differences between saline and acute EtOH groups within Ch-treated females (Fig. 23, $p=0.747$).

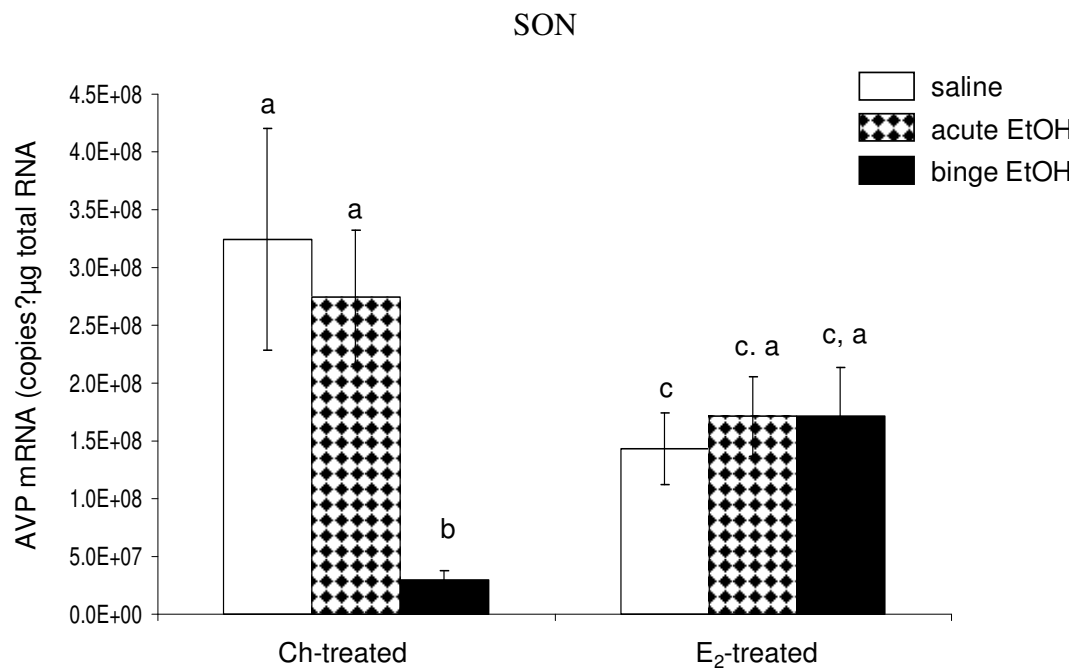

Fig 23. Effects of ethanol treatments on AVP gene expression in the SON in ovariectomized female rats. AVP mRNA expression in SON of peri-pubertal Ch- or E₂-treated female rats treated with saline, acute, or binge EtOH. Data expressed as mRNA copies/ μ g total RNA. Dissimilar letters indicate statistically significant difference. More specifically a is significantly different from b and c but not from ca ($P < 0.05$).

17 β -Estradiol treatment in vitro abolished EtOH induced changes in CRH promoter activity

In order to investigate possible interactions of EtOH with E₂ on the activity of the CRH promoter, I treated IVB cells transfected with CRH promoter-luciferase construct with 100 mM EtOH or 100 mM EtOH plus 10 nM E₂ and measured luciferase activity (see Chapter 7 General Methods section for details). Statistical analysis revealed that EtOH significantly increased the CRH promoter activity as compared to vehicle treated controls (Fig 24, p=0.016) but in the presence of E₂ this EtOH effect was abolished (Fig 24, p=0.539). These data indicate that the presence of E₂ modulates EtOH induced effects exerted on CRH promoter.

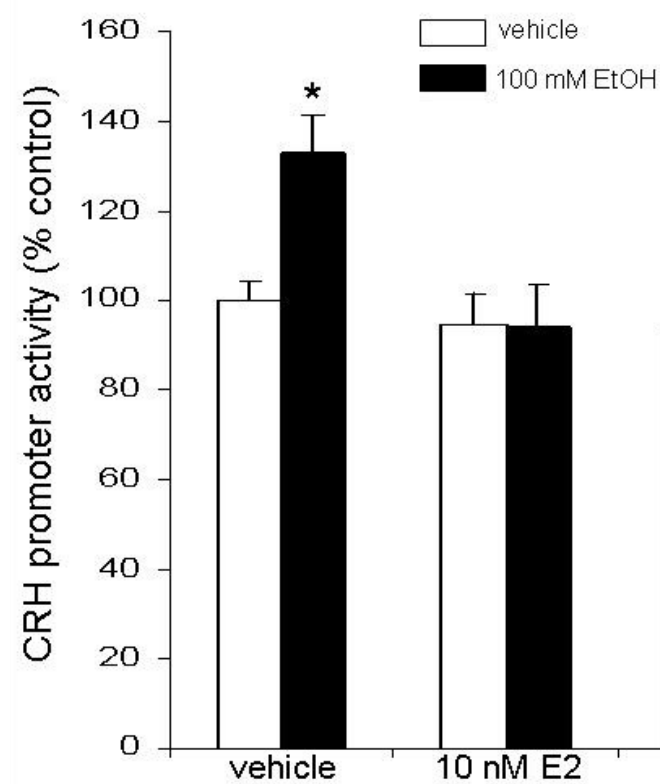

Fig 24. Effects of EtOH treatment on CRH promoter activity in a neuronal cell line after E₂ treatment. CRH promoter-luciferase activity was measured in IVB cell line in cells transfected with CRH promoter-luciferase construct after treatment with 100 mM EtOH for 2.0 h in media alone or in the presence of 10 nM E₂. Data expressed as % change in luciferase activity of vehicle treated control. * indicates statistically significant different compared to vehicle treated control (P < 0.05)

Discussion

We have shown previously that binge alcohol exposure during peri-puberty induced sexually dimorphic changes in the PVN expression of CRH and AVP mRNA but the pattern of alcohol induced changes in plasma CORT levels was the same in females as in males (Przybycien-Szymanska, Rao et al. 2009). These data indicated sex specific dysregulation of peri-pubertal HPA axis. To date, mechanisms behind these effects have not been described. The goals of this study were to investigate 1) the effects of binge EtOH exposure in ovariectomized peri-pubertal females and a role of E₂ replacement in modulating these effects and 2) effects of EtOH treatment in a presence of estradiol on the CRH promoter activity. These results showed for the first time that 1) in Ch-treated ovariectomized females, binge EtOH exposure significantly decreased CRH and AVP mRNA in the PVN and both acute and binge EtOH exposures significantly increased circulating CORT levels, 2) that in E₂-treated ovariectomized females, alcohol did not induce changes in the CRH and AVP mRNA in the PVN and only acute EtOH exposure significantly increased plasma CORT levels in this group. *In vitro* data presented herein showed that estradiol treatment prevented EtOH induced increase in CRH promoter activity at the 2.0 h time. These data indicate that E₂-EtOH interaction are potentially responsible for sex differences in responsiveness of the HPA axis to alcohol administration as in the presence of estradiol *in vivo* and *in vitro* these effects of alcohol were abolished (see Fig 25 for the summary of major findings)

SUMMARY: Effect of binge EtOH exposure in ovariectomized females**Ch-treated females (PND 37-44)**

- BINGE EtOH ↓ CRH and AVP mRNA in the PVN
- Both binge and acute EtOH ↑ plasma CORT levels, no habituation

E₂-treated females (PND 37-44)

- NO CHANGES in the CRH and AVP mRNA after EtOH treatments
- Both binge and acute EtOH treatments ↑ CORT levels, habituation effect present

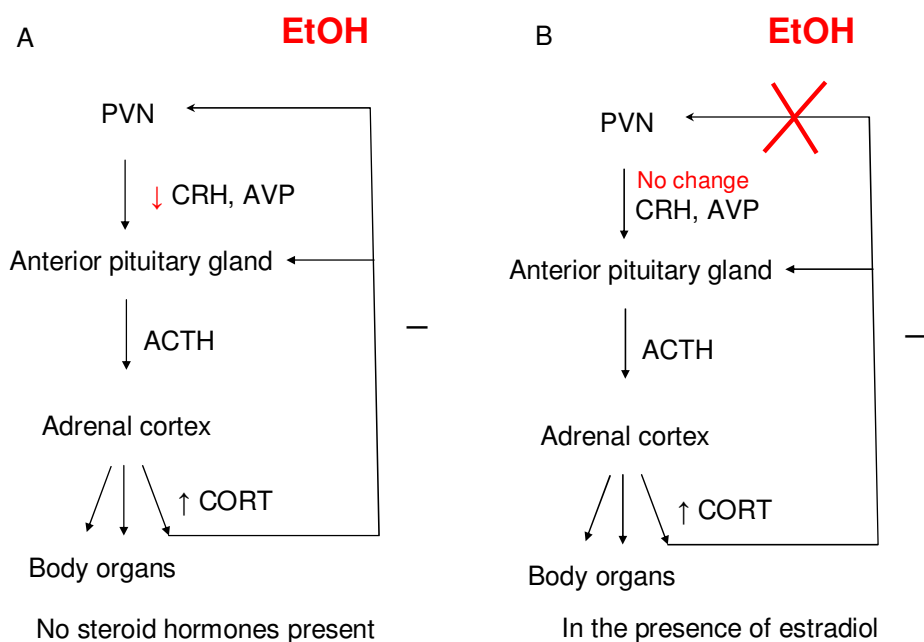

Fig 25. Summary of results described in Chapter 4. In OVX Ch-treated females (A) binge EtOH exposure ↓ CRH and AVP mRNA in the PVN and ↑ plasma CORT levels. In OVX estradiol replaced females (B), binge EtOH exposure did not induce changes in the CRH and AVP mRNA in the PVN but ↑ plasma CORT levels. These data indicate that the presence of estradiol is required for the maintenance of steady state levels of the CRH and AVP mRNA in the PVN after EtOH exposures.

In this study, both acute and binge EtOH exposure increased circulating ACTH and CORT levels in Ch-treated ovariectomized females, however, in E₂-treated females only acute EtOH exposure significantly increased plasma ACTH and CORT levels. Notably, in these females ACTH and CORT levels were similar between saline and binge alcohol treated groups indicating a clear habituation effects after repeated EtOH exposure. These data are consistent with our previous reports in intact peri-pubertal male and female rats in which we showed that there was a habituation effect after repeated EtOH administrations marked by lower increase in plasma CORT levels after binge EtOH treatment compared to plasma CORT levels after acute EtOH exposure (Przybycien-Szymanska, Rao et al. 2009). Data presented in this report indicate that the presence of estradiol is required for habituation effects because in Ch-treated females there was no difference between plasma ACTH and CORT levels between the two alcohol treated groups.

In addition to the role of E₂ in the habituation effect after binge EtOH exposure, these data support previous finding describing the role of E₂ in increased sensitivity to stressful stimuli in female animals. Plasma CORT levels after saline administration were higher in E₂-treated females compared to Ch-treated females. This is consistent with previous reports showing greater plasma CORT increase after stress and alcohol administration in females compared to males (Sencar-Cupovic and Milkovic 1976; Rivier 1993; Ogilvie and Rivier 1997; Evuarherhe, Leggett et al. 2009; Weiser and Handa 2009). Our previous

experiments showed that CORT levels in intact peri-pubertal males and females were not different between saline treated groups as compared to untreated rats, however saline injection could be considered to be a mild stressor inducing a small increase in circulating CORT levels and these effects were significantly greater in females compared to males. These data indicate and further support findings showing increased sensitivity to stress in females and a role of E₂ in this increased sensitivity.

Contrary to what was observed in peri-pubertal (Przybycien-Szymanska, Rao et al. 2009) and adult animals (Rivier 1993; Ogilvie and Rivier 1996; Ogilvie and Rivier 1997), E₂ failed to induce a greater increase in CORT levels after EtOH administration in E₂-treated females as compared to Ch-treated group. This could be explained by lack of other sex steroid hormones that would inhibit the HPA axis. One such hormone, testosterone (T), is known to play inhibitory role on stress induced functions of the HPA axis marked by decreased ACTH and CORT increase when compared to females and increased basal CORT levels in gonadectomized males (Ogilvie and Rivier 1997; Viau, Chu et al. 1999; Williamson and Viau 2008; Evuarherhe, Leggett et al. 2009). The fact that plasma ACTH and CORT levels were not different after EtOH administration between CH- and E₂-treated females could be explained by the fact that there was no HPA axis inhibition.

A most striking finding of these experiments is that E₂ replacement abolished alcohol induced changes in the CRH and AVP mRNA in the PVN which is consistent with previous data showing no changes in the expression of

these neuropeptides in the PVN of peri-pubertal (Przybycien-Szymanska, Rao et al. 2009) and adult female rats (Ogilvie and Rivier 1997). These data indicate a role of E₂ in lack of EtOH induced changes in the CRH and AVP mRNA expression in the PVN, however, it is not clear what is the role this lack of EtOH effects on the CRH and AVP mRNA in the PVN in females and what causes an increase in these genes in the PVN of intact males observed in previous studies (Rivier, Bruhn et al. 1984; Ogilvie and Rivier 1996; Rivier and Lee 1996; Ogilvie, Lee et al. 1997; Ogilvie and Rivier 1997; Przybycien-Szymanska, Rao et al. 2009). Notably, in Ch-treated females lack of E₂ alone did not increase CRH and AVP mRNA in the PVN, therefore E₂ cannot be the only factor involved in sexually dimorphic effects of EtOH. Notably, in Ch-treated females, I observed a decrease in the CRH and AVP mRNA in the PVN which indicates that some other factor, not present in gonadectomized females, is responsible for EtOH induced increase in the CRH and AVP mRNA in male PVN.

It has been shown that in addition to E₂, T and its metabolites such as 3β-diol and dihydrotestosterone (DHT), differently modulate the HPA axis activity (De Vries, Wang et al. 1994; Viau and Meaney 1996; Viau, Chu et al. 1999; Viau, Lee et al. 2003; Scordalakes and Rissman 2004; Lund, Hinds et al. 2006; Pak, Chung et al. 2007; Williamson and Viau 2008; Handa, Weiser et al. 2009; Pak, Chung et al. 2009) and that this effect can be mediated through estrogen receptor beta (ER β), the main ER found in the PVN (Isgor, Cecchi et al. 2003; Miller, Suzuki et al. 2004; Lund, Rovis et al. 2005; Suzuki and Handa 2005; Pak, Chung et al. 2007; Handa, Weiser et al. 2009) or through androgen receptor

signaling present in the PVN and in other hypothalamic regions (Viau and Meaney 1996; Lund, Hinds et al. 2006). For example, in bed nucleus of stria terminalis (BST) of gonadectomized adult rats, DHT and E₂ increased AVP mRNA as compared to gonadectomized rats not replaced with any hormones. The same is true in medial nucleus of amygdala (MeA) (De Vries, Wang et al. 1994; Pak, Chung et al. 2009). In juvenile rats, on the other hand, E₂ and 3 β -diol, but not DHT, increase AVP mRNA expression in BST but only E₂ increased AVP mRNA expression in MeA (Pak, Chung et al. 2009). 3 β -diol is known to activate the AVP promoter activity in a neuronal cell line (Pak, Chung et al. 2007; Pak, Chung et al. 2009). In addition to inhibiting ACTH and CORT release, T can also inhibit the HPA axis at the level of the hypothalamus where it has been found to decrease restraint induced changes in the CRH expression (Patchev and Almeida 1996; Viau and Meaney 1996; Viau, Chu et al. 1999; Viau, Lee et al. 2003; Williamson and Viau 2008). In our Ch-treated animals, lack of any sex steroid hormones could be partially responsible for a decrease in the CRH and AVP mRNA in the PVN due to EtOH but more studies need to be performed in order to elucidate exactly what factors are required for EtOH induced increase in the CRH and AVP mRNA in the PVN.

Another possibility behind EtOH induced decrease in the CRH and AVP mRNA in the PVN of ovariectomized Ch-treated females, further supporting the role of E₂, is that these females lack E₂ mediated neuroprotection. E₂ has been shown in multiple studies to exert neuroprotective effects after a neuronal insult (Li, Siegel et al.; Pietranera, Bellini et al.; Garcia-Segura, Wozniak et al. 1999;

Azcoitia, Sierra et al. 2001; McCullough, Blizzard et al. 2003; Sierra, Azcoitia et al. 2003; Saleh, Connell et al. 2005; Veiga, Azcoitia et al. 2005). There is an increase in aromatase, an enzyme involved in conversion of T to E₂, activity after ischemic stroke and other brain insults (Garcia-Segura, Wozniak et al. 1999; Saleh, Connell et al. 2005; Veiga, Azcoitia et al. 2005). These findings indicate that a decrease in the CRH and AVP mRNA in the PVN could be explained by lack of neuroprotection against neurotoxic effects of EtOH; however, this still does not explain the reason why we see an increase in the expression of these neuropeptides in the PVN of intact males. It is possible that in peri-pubertal males an AVP increase in the PVN plays a neuroprotective role as these binge-EtOH exposed pubertal males have low levels of circulating E₂. AVP has been shown to be protective against apoptotic cell death in a neuronal cell line (Chen, Volpi et al. 2008; Chen, Liu et al. 2009) therefore it is likely to speculate that in males an upregulation of AVP plays a neuroprotective role. This explanation, however, still does not explain an increase in the CRH mRNA.

The role of E₂ in modulation of the HPA axis at the level of the hypothalamus is further supported by our *in vitro* data showing no EtOH induced increase in CRH promoter activity in the presence of E₂. These data are consistent with previous reports showing a close relationship between gonadal and adrenal hormones in regulation of the HPA and hypothalamo-pituitary-gonadal (HPG) axis, respectively. For example, E₂ and ERβ play a stimulatory role on the HPA axis activity. This enhancing effect is marked by increased CRH promoter activity after cotransfection of different ERβ isoforms and increased

AVP mRNA in the PVN, and enhanced increase in plasma ACTH and CORT after stress in the presence of E₂ (De Vries, Wang et al. 1994; Ogilvie and Rivier 1997; Miller, Suzuki et al. 2004; Weiser and Handa 2009). Adrenal hormones can in turn modulate the expression of ER β as adrenalectomy decreased ER β mRNA expression in the PVN of adult rats and this effects was fully reversed with CORT replacement (Isgor, Cecchi et al. 2003). Consistent with *in vivo* data showing no EtOH induced changes in the CRH mRNA expression in the PVN in intact females or in ovariectomized females replaced with E₂, in a neuronal cell line, E₂ treatment prevented EtOH induced stimulation of CRH promoter activity. These data indicate that there is close cooperation between EtOH and E₂ signaling and this interaction is involved in sex specific effects of EtOH exposure.

In this study binge EtOH exposure, did not change the AVP mRNA expression in the SON in E₂-treated group but it significantly decreased SON expression of this neuropeptides in Ch-treated group. Our data collected in E₂-treated ovariectomized females are consistent with previous reports showing no effects of EtOH treatments in the SON of normal rats (Ogilvie, Lee et al. 1997), or in magnocellular division of the PVN (Ogilvie and Rivier 1997). Notably, in Ch-treated group we observed a significant decrease in the AVP mRNA expression in the SON and this effect could be explained in two ways. First, data showing a decrease AVP in the SON is consistent with diuretic effects of alcohol on the AVP as the AVP is mostly known as antidiuretic hormone (ADH). This explanation is highly unlikely because we did not observe changes in the AVP mRNA expression in the SON in E₂-treated females and in intact peri-pubertal

male and female rats (Przybycien-Szymanska, Rao et al. 2009). If this decrease was due to diuretic effects of EtOH, we would see it in other studies as well.

Second, based on previous reports, I can speculate that EtOH could induce cell death in the PVN which would result in decreased expression of AVP mRNA in the SON. This explanation is consistent with previous reports showing that the AVP mRNA in the SON was decreased following alcohol exposure but only in rats bearing PVN lesions (Ogilvie, Lee et al. 1997) and AVP is neuroprotective in a PVN derived neuronal cell line (H32) (Chen, Volpi et al. 2008; Chen, Liu et al. 2009). In these experiments, addition of the AVP into the media was found to protect against serum starvation induced cell death (Chen, Volpi et al. 2008; Chen, Liu et al. 2009). EtOH induced cell death in the PVN could be responsible for a decrease in the AVP mRNA in the PVN in Ch-treated females. If that was the case, the decrease in the AVP mRNA in the SON could be explained by the cooperation between these two nuclei. Functions of the PVN and SON and their responses to EtOH have been shown to be linked (Ogilvie, Lee et al. 1997). The cooperation between both magnocellular and parvocellular AVP systems needs to be further investigated in order to support this hypothesis even though this explanation at this moment seems to be most likely.

Lastly, we showed that E₂-treated females had significantly lower body weights and gained weight slower as compared to Ch-treated females but EtOH treatment had no effects on body weight. These findings are consistent with known anorexigenic effects of E₂, as lack of this hormone in humans, for example during menopausal transition in women, tends to increase body weights

(Cagnacci, Zanin et al. 2007). In addition, body weight data in EtOH treated groups showed the binge alcohol exposure paradigm employed in our experiments did not inhibit the growth of animals. This is consistent with our previous data which showed no differences in body weights due to EtOH treatment (Przybycien-Szymanska, Rao et al. 2009). In addition this binge EtOH exposure paradigm has been shown to be reliable for testing the effects of EtOH using an exposure pattern that is typical for adolescents (Lauing, Himes et al. 2008). Lastly, it has been shown that the IP injection of EtOH, employed in our paradigm, does not seem to result in significantly different BAC compared to oral gavage in adolescent Wistar rats (Walker and Ehlers 2009).

Taken together, our data show for the first time that E_2 plays a critical role in mediating sexually dimorphic effects of EtOH and that these effects of E_2 may be exerted at the level of the CRH promoter. Further studies need to be performed in order to investigate mechanisms involved in increase in the CRH and AVP mRNA in the PVN of intact peri-pubertal male rats after binge EtOH exposure as the absence of E_2 does not explain this increase. In addition, we need to establish whether the presence of E_2 in the system makes females protected or more sensitive to the effects of E_2 as compared to males. If they are more sensitive, this increase in sensitivity to E_2 effects may lead females who binged during adolescence to exhibit even greater risk for developing mood disorders in adulthood as compared to males.

CHAPTER FIVE

BINGE-PATTERN ALCOHOL EXPOSURE DURING PUBERTY INDUCES LONG-TERM CHANGES IN HPA AXIS REACTIVITY. (PRZYBYCIEN- SZYMANSKA MM ET AL., PLOS ONE APRIL 2011)

Introduction

Alcohol abuse, especially binge-pattern alcohol abuse, is highly prevalent among adolescents. According to the Substance Abuse and Mental Health Services Administration, 36% of youths ages 18 to 20 reported at least one binge-drinking episode during the past 30 days, defined by National Institute on Alcohol Abuse and Alcoholism (NIAAA) as consuming four or five drinks within a two hour period that causes a rapid increase in blood alcohol concentration (BAC) to the level of 0.08 g % or greater. Our previous studies demonstrated that binge-pattern EtOH exposure in adolescent rats negatively affected the HPA axis by dysregulating normal negative feedback pathways, however whether these neurobiological changes were transient or persistent remained unclear (Przybycien-Szymanska, Rao et al. 2009). Thus, a central focus of this study was to determine the long-term neurobiological consequences of adolescent binge-pattern alcohol exposure on adult HPA axis reactivity. The HPA axis is extremely plastic during pubertal development, suggesting that early alcohol

abuse could permanently disrupt the normal maturational process of the HPA axis. Alcohol is a physiological stressor and potent activator of the HPA axis (Rivier and Lee 1996; Ogilvie, Lee et al. 1997; Li, Kang et al. 2005; Przybycien-Szymanska, Rao et al. 2009). Acute psychological or physical stressors activate parvocellular neurons in the hypothalamic paraventricular nucleus (pPVN) to release corticotrophin releasing hormone (CRH) and arginine vasopressin (AVP) into the portal system of the anterior pituitary gland, which, upon stimulation, releases adrenocorticotrophic hormone (ACTH). ACTH then acts on the adrenal cortex to release glucocorticoids, cortisol in humans and corticosterone (CORT) in rodents, into the systemic circulation setting up a negative feedback loop by which CORT acts on the hypothalamus and pituitary gland to decrease further release of CRH, AVP, and ACTH. During pubertal development, the brain and HPA axis undergo extensive maturational processing, characterized by altered HPA axis reactivity, increased synaptic connections, and differential responsiveness to the effects of gonadal steroid hormones (Sisk and Zehr 2005; Romeo, Bellani et al. 2006; McCormick and Mathews 2007; Evuarherhe, Leggett et al. 2009; Evuarherhe, Leggett et al. 2009). These studies indicate that the successful shaping of mature HPA function that occurs during pubertal development may be extremely vulnerable to the detrimental effects of alcohol.

We have previously shown that binge-pattern EtOH exposure in peri-pubertal male rats increased the expression of CRH and AVP mRNA in the PVN during this time period (Przybycien-Szymanska, Rao et al. 2009), however the long lasting effects of this pattern of EtOH exposure during puberty on the PVN

and the HPA axis as a whole remain unknown. In this study we tested the hypothesis that binge-pattern EtOH exposure during puberty has long lasting effects on the reactivity of the adult HPA axis. The overall goals of this study were to 1) determine how binge-pattern EtOH exposure during puberty affects central expression of adult CRH and AVP, as well as circulating CORT levels, and 2) determine whether adults pre-exposed to EtOH during puberty were more sensitive to subsequent EtOH exposures in adulthood. Overall, our results showed that peri-pubertal binge-pattern EtOH exposure induced a striking long lasting alteration of many HPA axis parameters. Our data provide strong evidence that binge-pattern EtOH exposure during pubertal maturation has long-term detrimental effects for the healthy development of the HPA axis.

Results

General Approach

In order to investigate the long lasting effects of binge EtOH exposure during puberty on functioning of adult HPA axis, peri-pubertal male rats (PND 37-44) were exposed to saline (EtOH naïve) or binge EtOH exposure paradigm (EtOH pre-exposed) and then allowed to grow up undisturbed until adulthood. Starting on PND 68 (early adulthood), male rats were treated with following regiments 1) saline only, 2) acute EtOH exposure or 3) binge EtOH exposure for 8 consecutive days (see Fig 2 and Table 3 for detailed description of binge EtOH exposure paradigm and experimental design). On the last day of adult treatments (PND 75), 1.0 h after saline or EtOH administration, animals were sacrificed and

he brains and trunk blood were collected. Plasma was separated and used for further BAC and hormone measurement. Brains were rapidly frozen, then sectioned on a freezing microtome and the PVN and SON were microdissected to perform CRH and AVP mRNA measurements using qRT-PCR (see Chapter 7 General Methods section for detailed description of methods used)

Effects of binge EtOH exposure on body mass and growth rate.

In order to investigate the long lasting effects of binge EtOH exposure during puberty, pubertal and then adult male rats were treated according to our binge EtOH exposure paradigm (Fig 2 and Table 3). Animals at PND 37 were randomly assigned to either 1) saline-treated (N = 30) or 2) binge EtOH treated (N = 30, 3g/kg/day) groups and then allowed to grow till adulthood. On PND 68 (early adulthood) each group was divided into following treatment groups (Table 3): 1) saline only control groups (N=10); 2) acute EtOH groups (N=10) and 3) binge EtOH groups (N=10).

Experimental Design 2

<u>Puberty (PND37-44)</u>	<u>Adult (PND 68-75)</u>
EtOH naïve Saline (n = 30)	Saline (n=10)
	Acute EtOH (n=10)
	Binge EtOH (n=10)
EtOH pre-exposed Binge EtOH (n = 30)	Saline (n=10)
	Acute EtOH (n=10)
	Binge EtOH (n=10)

Table 3. *Experimental design 2.* During pubertal development animals were divided in two treatment groups, saline (ip injection of saline once a day for 8 days) or binge EtOH treatment (3 days of ip injections of 3g/kg EtOH, followed by 2 days of saline and again by 3 days of EtOH injections). After pubertal treatments animals were undisturbed for a month and then in adulthood each pubertal treatment group was divided into 3 subsequent treatment groups; 1) saline, 2) acute EtOH (7 days of saline followed by 1 day of 3g/kg EtOH injections), or 3) binge EtOH .

Body weights were measured every other day during the duration of both pubertal and adult treatments to determine whether pubertal binge pattern EtOH exposure altered normal growth patterns. Growth curves for each treatment group (Fig. 26A), and combined groups based on EtOH exposure during puberty (Fig. 26B), show that there was a significant weight difference between animals exposed to binge pattern EtOH starting from the fifth day of pubertal treatment (Fig 26B, $p < 0.01$). The weight difference increased by the last day of treatment during puberty and persisted during the time when animals were undisturbed and throughout the adult treatment regiment (Fig 25B, $p < 0.001$). Animals did not lose weight at any point, despite the fact that the animals that received binge EtOH treatment had significantly lower body weights compared to saline-treated controls. Interestingly, subsequent binge EtOH exposure in adulthood did not further alter the growth pattern of adult animals (Fig 26).

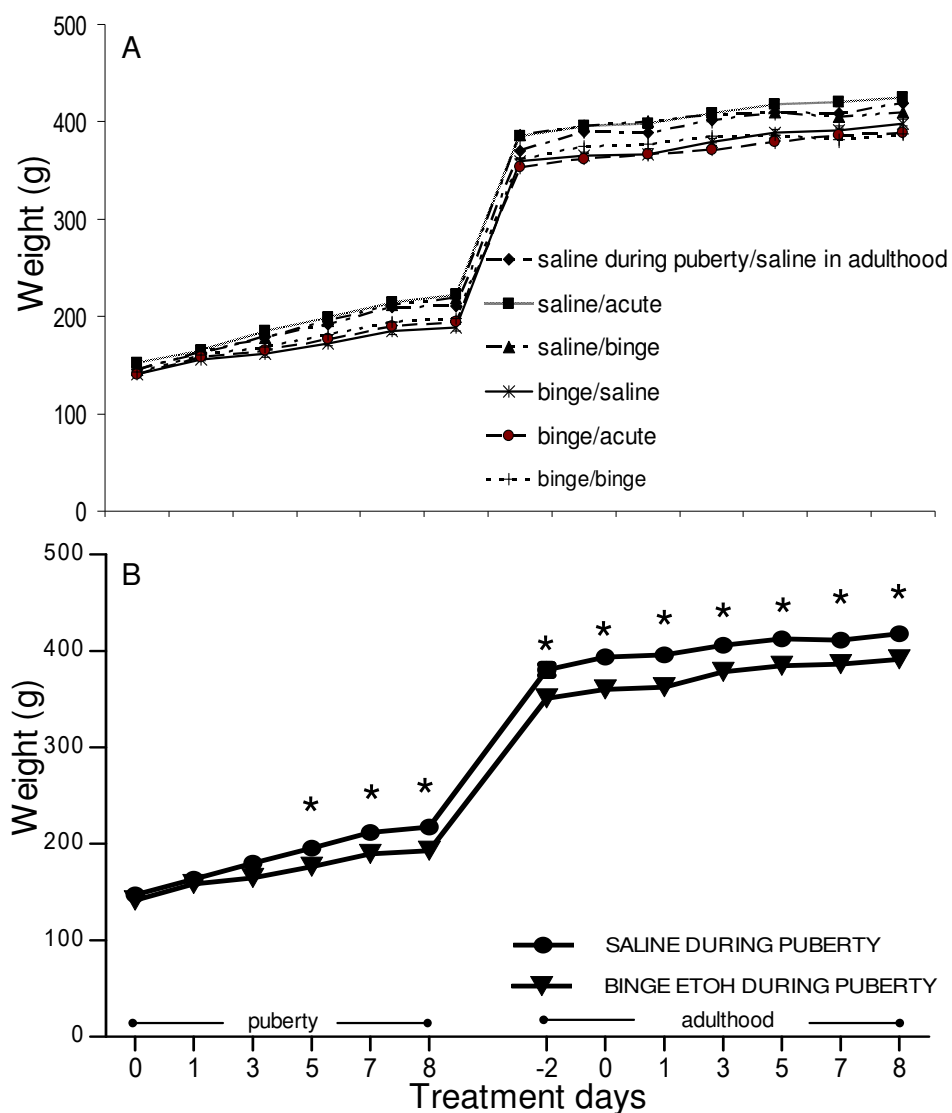

Fig 26. Effects of ethanol treatment on body weight during puberty and adulthood. Mean body weights of male animals untreated treated with daily IP injections of saline, saline + one day EtOH (acute), or binge EtOH paradigm. (A) represents body weights in all groups separately and (B) shown combined body weight based on pubertal treatment (saline or binge EtOH exposure). Data presented as mean body weight (g). * represents statistically significant difference as compared to saline treated group on a given treatment day ($p < 0.05$).

BAC following adult acute and binge EtOH exposure.

BACs were measured on the final day of adult treatment 60 min following the injections. There were no statistically significant differences in BAC between either acute (205.1 ± 21.8 ; 221.8 ± 19.1 for EtOH naïve and EtOH pre-exposed groups, respectively) or binge EtOH treated groups (172.9 ± 27.0 ; 208.2 ± 28.2 for EtOH naïve and EtOH pre-exposed groups, respectively) (Fig 27). BAC in animals treated with saline were below the limit of detection for the assay. Interestingly, prior EtOH exposure (i.e. EtOH pre-exposed binge group) had no effect on adult BAC after either acute or binge EtOH treatments. The values observed in EtOH-treated groups are consistent with the defined BAC threshold for binge drinking (80 mg/dl) and showed that all EtOH-treated groups were intoxicated to the same degree.

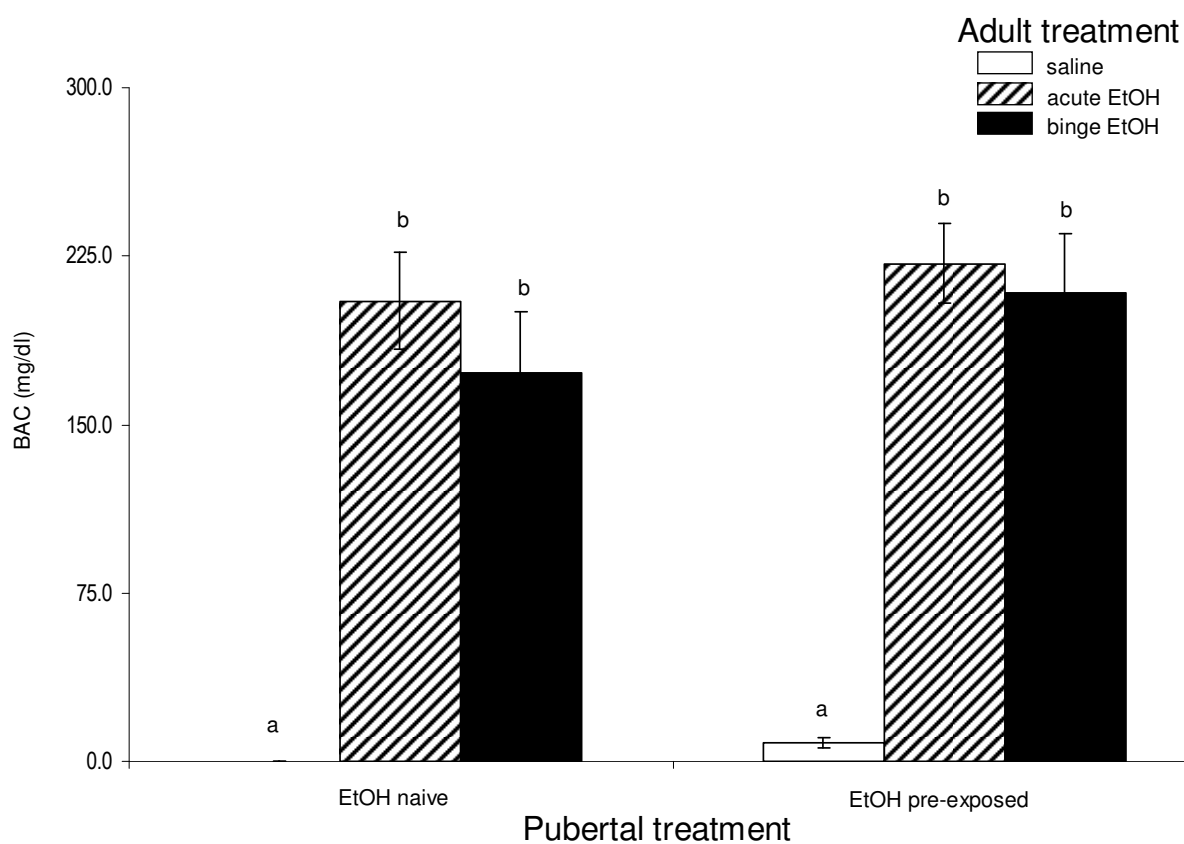

Fig 27. Adult blood alcohol concentrations (BAC) following EtOH treatment. BAC 1.0 h post-injection in adult animals pre-treated during peri-puberty with either saline (EtOH Naïve) or binge EtOH paradigm (EtOH pre-exposed) then treated with saline, acute EtOH or binge EtOH as adults. Data expressed as mean EtOH mg/dl. Dissimilar letters indicate statistically significant difference between groups. More specifically a is significantly different from b ($P < 0.05$).

*Binge-pattern EtOH exposure during peri-puberty significantly altered adult
CORT levels.*

Circulating CORT levels were measured by RIA to determine whether binge EtOH exposure during puberty affected responsiveness of the HPA axis to subsequent EtOH exposures in adulthood. All measurements were taken in adult animals and they were classified as either EtOH pre-exposed or EtOH naïve. Three different measures of adult HPA reactivity, as ascertained from plasma CORT levels, were compared: 1) basal pre-stress, 2) sensitivity to a single EtOH exposure (acute stress), and 3) sensitivity to repeated EtOH exposure (binge – repeated stress). Two-factor ANOVA was used to assess main effects of pubertal and adult treatments and interactions between these two factors. Every parameter measured was significantly different between animals that were EtOH pre-exposed compared with those that only received saline during puberty (EtOH naïve). There was a statistically significant main effect of EtOH treatment during adulthood ($F(2,51) = 71.218, p < 0.001$), no significant main effect of treatment during puberty ($F(1,51) = 3.305, p = 0.075$) and a there was a significant interaction between pubertal and adult treatment ($F(2, 51) = 4.458, p = 0.016$). Overall, our data revealed that the pattern of plasma CORT responses were significantly different depending on whether the animals were pre-exposed to EtOH (Fig. 28). Notably, basal levels of plasma CORT were significantly lower in animals that had previously been exposed to EtOH during pubertal development compared with EtOH naïve animals ($t(17) = 3.23, p = 0.005$, Fig. 28, open bars). Second, plasma CORT levels in animals that were pre-exposed to EtOH during

puberty were significantly higher following adult treatment with a single (acute) ($t(18) = -2.247$, $p = 0.037$) or binge-pattern EtOH ($t(15) = -2.218$, $p = 0.042$) (Fig. 28, hatched and solid bars), suggesting that the adult animals were more sensitive, or that the HPA axis was potentially more responsive, to the stressful effects of EtOH. Animals that did not have prior EtOH exposure also had significantly elevated CORT levels following EtOH treatment in adulthood ($F(2, 27) = 34.105$, $p < 0.001$), but as mentioned above, it was significantly lower than the animals that were pre-exposed. Finally, animals that were pre-exposed to EtOH during puberty failed to habituate to the binge-treatment paradigm as indicated by their equivalently higher plasma CORT levels following a subsequent acute or binge EtOH treatment ($p = 0.358$, Fig. 28). By stark contrast, animals that received saline during puberty (EtOH naïve) did show a habituation effect to the repeated binge EtOH treatment ($p = 0.003$), which is consistent with our previous reports in peri-pubertal animals.

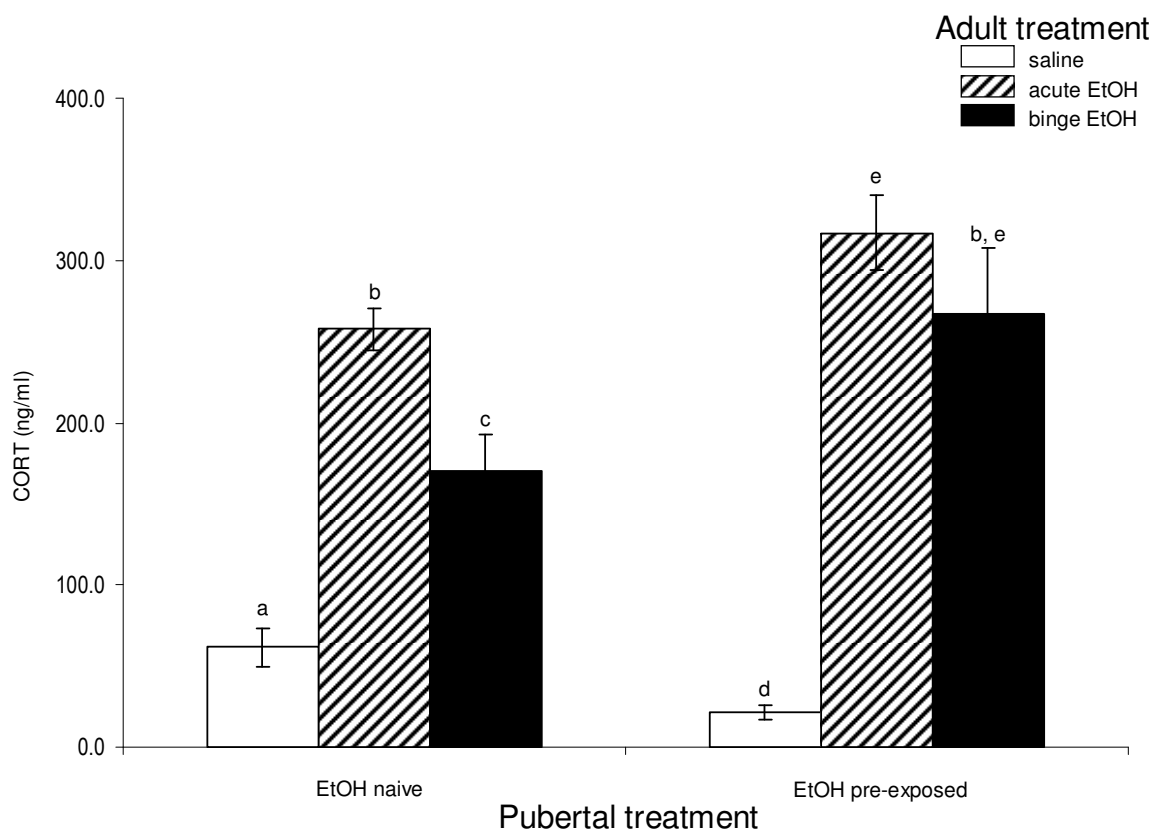

Fig 28. *Effects of pubertal binge EtOH pre-treatments on plasma CORT levels in EtOH exposed adult animals.* Plasma corticosterone (CORT) levels 1.0 h post-injection in adult animals pre-treated with either saline (EtOH Naïve) or binge EtOH paradigm (EtOH pre-exposed) during peri-puberty and then treated with saline, acute EtOH or binge EtOH paradigm in adulthood. Data expressed as mean CORT ng/ml of blood. Dissimilar letters indicate statistically significant difference. More specifically a is significantly different from b, c, d, e and be; e is different from a, b, c, d, but not from be and so on ($P < 0.05$).

Binge-pattern EtOH exposure during puberty significantly altered responsiveness of adult CRH and AVP mRNA in the PVN to subsequent EtOH exposure.

Next, we measured CRH and AVP mRNA in the PVN using quantitative RT-PCR to determine the long-term effects of pubertal binge EtOH exposure on adult HPA axis reactivity. CRH and AVP mRNA were used as endpoints to ascertain three different measures of adult HPA axis status: 1) basal pre-stress, 2) sensitivity to a single EtOH exposure (acute stress), and 3) sensitivity to repeated EtOH exposure (binge – repeated stress). Two-way AVOVA showed that there was a main effect of EtOH treatment during puberty on adult CRH mRNA expression ($F(1, 42) = 8.641, p = 0.005$), as well as a main effect of pubertal treatment ($F(1, 44) = 4.876, p = 0.032$) and adult treatment ($F(2, 44) = 5.835, p = 0.006$) for AVP mRNA expression in the PVN (Fig 29 and 30). Similar to the results obtained with plasma CORT levels, the patterns of gene expression for CRH and AVP were significantly different depending on whether the animals were pre-exposed to EtOH or EtOH naïve.

Basal pre-stress levels of CRH mRNA was significantly higher in animals that were exposed to EtOH during puberty compared with those that received saline (EtOH naïve) ($t(14) = -2.175, p = 0.047$) (Fig. 29, open bars). A single (acute) dose of EtOH significantly increased CRH mRNA levels ($t(14) = -2.363, p = 0.033$) in animals that were pre-exposed to EtOH during adolescence, yet had no effect in animals that were EtOH naïve (Fig. 29, hatched bars). Conversely, binge-pattern EtOH exposure significantly increased CRH mRNA levels in EtOH pre-exposed animals compared to EtOH naïve, however the levels were not

statistically different from the baseline levels of EtOH pre-exposed animals (Fig. 29, solid bars).

Pre-exposure to EtOH during puberty had no effect on baseline levels of adult AVP mRNA ($t(15) = -1.342$, $p = 0.199$, Fig. 30, open bars). However compared to baseline, a single (acute) dose significantly decreased AVP mRNA levels in EtOH naïve animals ($t(15) = -2.214$, $p = 0.043$), but had no significant effect compared to baseline in animals pre-exposed to EtOH (Fig. 30, hatched bars). Binge-pattern EtOH exposure significantly decreased AVP mRNA levels compared to baseline in both groups, however the levels were only different from acute EtOH treatment in the pre-exposed group (Fig. 30, solid bars).

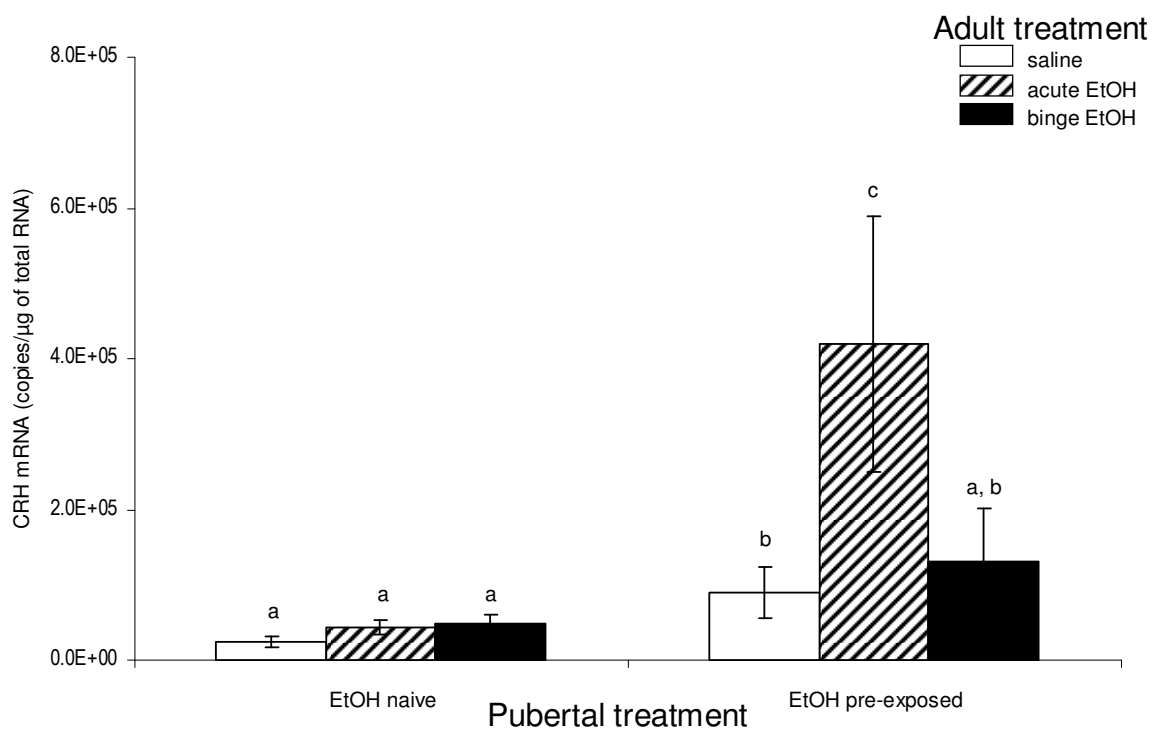

Fig 29. Effects of pubertal binge EtOH pre-treatments on CRH gene expression in the PVN of EtOH exposed adult rats. CRH mRNA expression in adult animals pre-treated with either saline (EtOH naïve) or binge EtOH paradigm (EtOH pre-exposed) during peri-puberty and then treated with saline, acute EtOH or binge EtOH in adulthood. Data expressed as mRNA copies/ μ g total RNA. Dissimilar letters indicate statistically significant difference between groups. For example, a is significantly different from b and c but is not significantly different from ab, c is different from a, b and ab ($P < 0.05$).

PVN

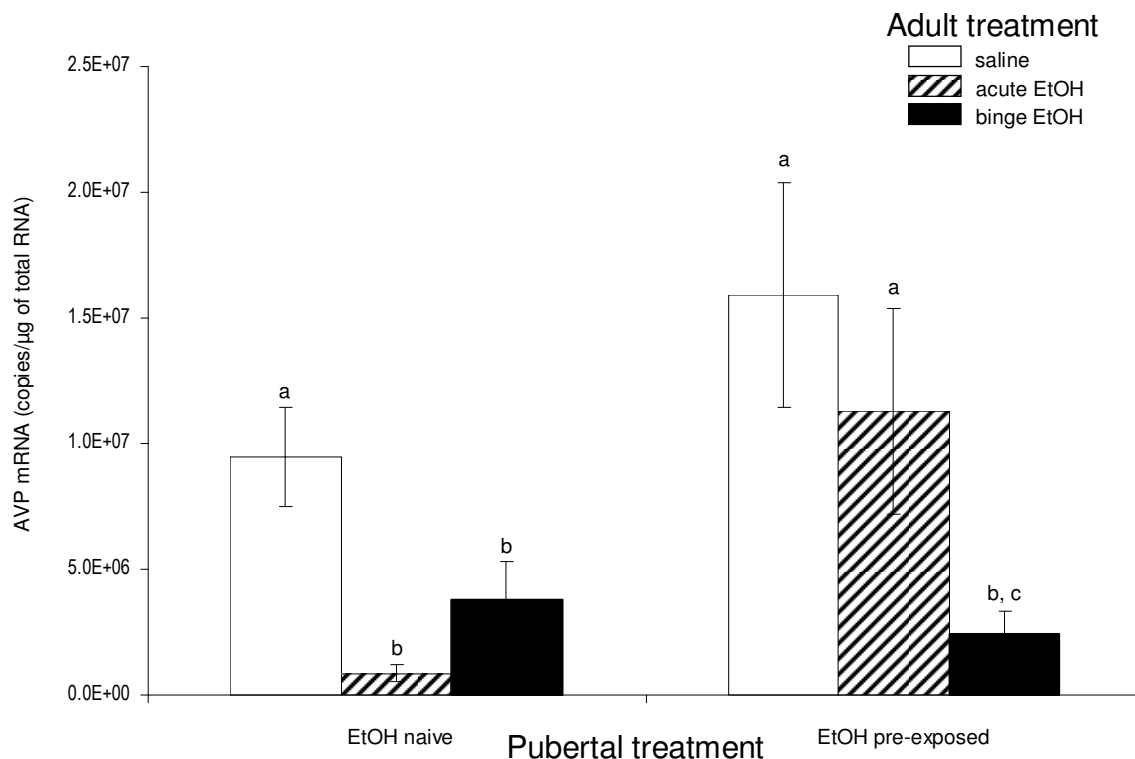

Fig 30. Effects of pubertal binge EtOH pre-treatments on AVP gene expression in the PVN of EtOH exposed adult rats. AVP mRNA expression in adult animals pre-treated with either saline (EtOH naïve) or binge EtOH paradigm (EtOH pre-exposed) during peri-puberty and then treated with saline, acute EtOH or binge EtOH in adulthood. Data expressed as mRNA copies/μg total RNA. Dissimilar letters indicate statistically significant difference. More specifically a is significantly different from b and bc; b is different from a but not bc ($P < 0.05$).

Binge EtOH exposure during puberty does not change the expression of the AVP mRNA in adult SON.

To confirm that the observed changes in the expression of the AVP mRNA in PVN after EtOH treatments were not due to the reported diuretic effects of alcohol, we measured AVP mRNA expression in the supraoptic nucleus of the hypothalamus (SON), a region responsible for maintaining water homeostasis. Two way AVOVA showed no main effects of either pubertal ($F(1, 48) = 0.65, p = 0.424$) or adult ($F(2, 48) = 1.72, p = 0.19$) treatment and no significant interactions between treatments during puberty and during adulthood ($F(2,48) = 1.359, p = 0.267$) (Fig 31).

SON

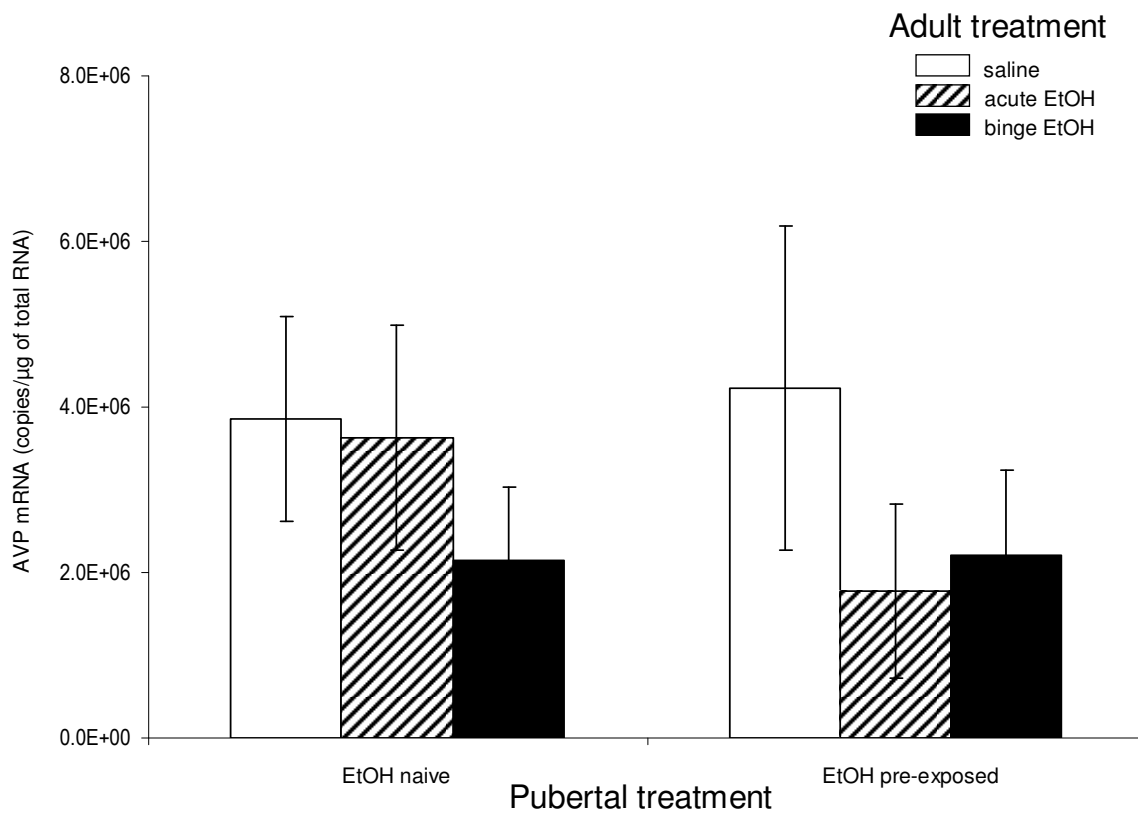

Fig 31. Effects of pubertal binge EtOH pre-treatments on AVP gene expression in the SON of EtOH exposed adult rats. AVP mRNA expression in adult animals pre-treated with either saline (EtOH naïve) or binge EtOH paradigm (EtOH pre-exposed) during peri-puberty and then treated with saline, acute EtOH or binge EtOH in adulthood. Data expressed as AVP mRNA copies/μg total RNA.

Discussion

The goals of this study were to 1) identify the long lasting effects of binge EtOH exposure during pubertal development on the maturation of the HPA axis by measuring circulating CORT, and hypothalamic neuropeptides (CRH and AVP), previously identified to be susceptible to EtOH effects and 2) determine whether binge-pattern EtOH exposure during puberty renders the adult HPA axis more sensitive, or responsive, to subsequent EtOH exposure. The most striking finding of our study was that exposure to binge-pattern EtOH during puberty resulted in a permanent dysregulation of the adult HPA axis, which is consistent with our hypothesis and is substantiated by the following data. First, adult animals that were previously exposed to binge-pattern EtOH during puberty had significantly lower circulating basal CORT levels, yet increased basal CRH mRNA expression in the PVN. We previously showed that peri-pubertal animals exposed to binge-pattern EtOH had significantly elevated levels of CRH and AVP mRNA in the PVN (Przybycien-Szymanska, Rao et al. 2009) and the present data demonstrate that those observed elevated CRH levels are maintained well into adulthood. Second, binge EtOH exposure during puberty sensitized the adult HPA axis to subsequent stressful stimuli (acute EtOH exposure), evident by a marked increase in adult levels of CRH mRNA in the PVN and higher circulating CORT levels compared to controls following a single exposure to EtOH. Finally, the stress response to EtOH exposure was significantly exacerbated and there was no habituation effect following repeated doses of EtOH in adults that were previously exposed to binge-pattern EtOH during

pubertal development, which is contrary to the effects observed in adult EtOH naïve animals. Collectively, present results underscore the heightened reactivity of the adult HPA axis in animals previously exposed to alcohol during adolescence and suggest that EtOH might interfere with the normal development of the HPA axis. See Fig 32 for summary of major finding in Chapter 5.

SUMMARY: The effects of pubertal; binge EtOH exposure on adult HPA axis reactivity

EtOH naïve males (PND 68-74)

- NO CHANGES in CRH mRNA levels in the PVN after EtOH exposures
- Acute and binge EtOH exposures \uparrow plasma CORT levels, habituation effect present

EtOH pre-exposed males (PND 68-74)

- Acute EtOH \uparrow CRH and AVP mRNA in the PVN (as compared to EtOH naïve)
- In EtOH pre-exposed during puberty animals there was \downarrow basal plasma CORT levels (as compared to EtOH naïve)
- EtOH pre-exposed rats had ENHANCED \uparrow in plasma CORT after subsequent acute and binge EtOH, No habituation

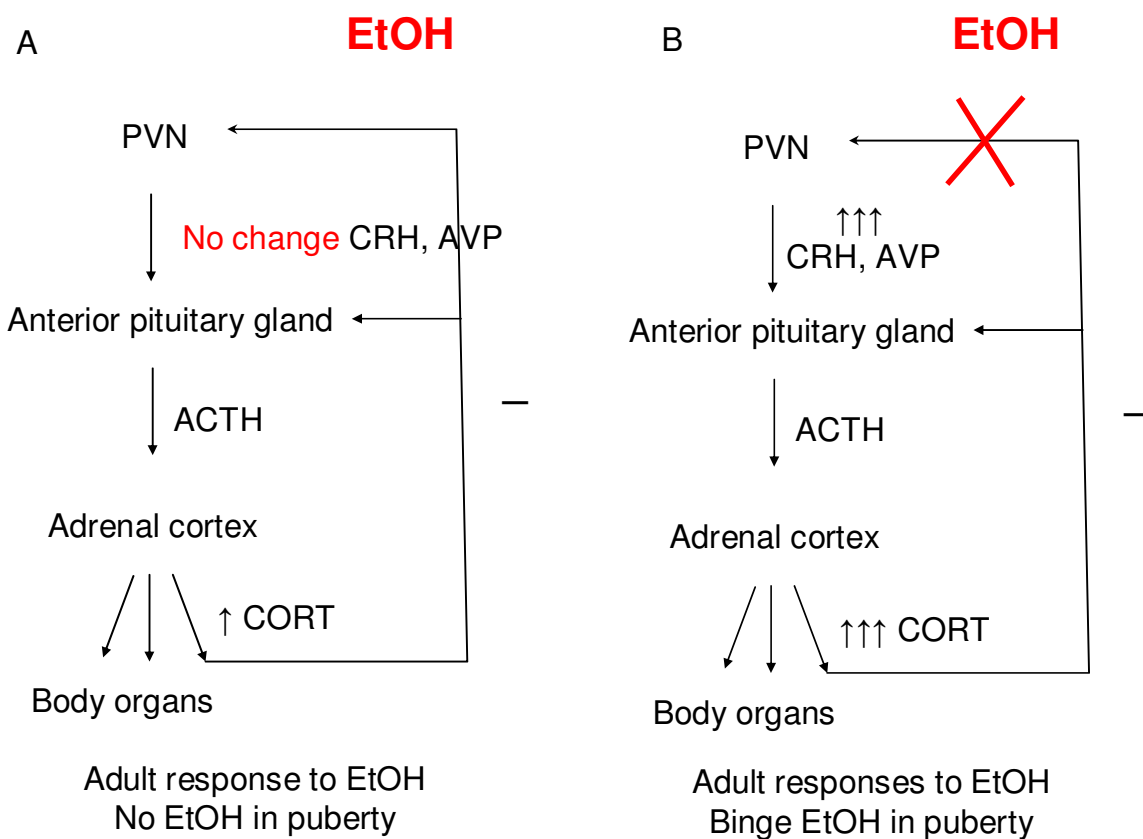

Fig 32. *Summary of results described in Chapter 5.* In EtOH-naive (A) binge EtOH exposure did not change CRH and AVP mRNA in the PVN and ↑ plasma CORT levels. In EtOH pre-exposed during puberty animals (B), binge EtOH exposure increased the CRH and AVP mRNA in the PVN and enhanced an increase in plasma CORT levels after acute and binge EtOH exposures. These data indicate that binge EtOH exposure during puberty induces long lasting changes in functioning of the HPA axis.

EtOH is a potent activator of the stress response as indicated by increased plasma CORT levels after both acute and binge treatments, however repeated doses over several days (i.e. binge-pattern) leads to an habituation effect (Przybycien-Szymanska, Rao et al. 2009). This same pattern has been observed with other types of psychological and physiological stressor (acute vs. chronic stress) in adult animals. Adult animals exhibit a high increase in CORT levels after exposure to a single predator stress however, after chronic homotypic stress this response is diminished (Figueiredo, Bodie et al. 2003). Herein, we have shown that animals exposed to acute or binge EtOH only during adulthood had increased plasma CORT levels and, as observed in pubertal animals, this effect was diminished following a binge-pattern of EtOH exposure indicating habituation of the HPA axis to the repeated homotypic stressor. By contrast, adult animals that received prior EtOH exposure during puberty not only had higher plasma CORT levels, but the habituation effect was not observed. These data indicate that after binge EtOH exposure during puberty, the HPA axis is not

only more sensitive to subsequent EtOH exposures but also that its normal ability to habituate to repeated stressors is compromised.

These data are consistent with other studies that show adult EtOH exposure alters the expression of CRH and AVP in the PVN (Rivier and Lee 1996; Ogilvie, Lee et al. 1997; Silva, Madeira et al. 2002; Silva, Paula-Barbosa et al. 2002). For instance, adult rats treated with a single 3g/kg EtOH dose had increased CRH and AVP mRNA in the PVN, whereas chronic dietary EtOH treatment reduced the number of AVP immunoreactive neurons in that same brain region (Silva, Madeira et al. 2002). Notably, the decreased AVP immunoreactivity was maintained 4 months after EtOH withdrawal in animals that received chronic dietary EtOH treatment, highlighting the potential for EtOH to exert a permanent effect on specific regulatory parameters of the HPA axis. We have shown previously that binge-pattern, but not acute, EtOH exposure during puberty increased both CRH and AVP mRNA in the PVN (Przybycien-Szymanska, Rao et al. 2009). Contrary to what has been observed in other studies in adult EtOH naïve animals, (Ogilvie, Lee et al. 1997; Ogilvie, Lee et al. 1997; Ogilvie, Lee et al. 1998), we did not observe an increase in the CRH mRNA levels in adult animals treated with acute EtOH exposure. This discrepancy is possibly due to differences in mRNA detection methods, as well as timing. In our study, we measured CRH and AVP mRNA levels one hour following the last EtOH injection. To our knowledge there are no other reports that have measured CRH and AVP gene expression this early following EtOH exposure. In this study, we show that this increased gene expression persists

into adulthood regardless of subsequent EtOH exposure, although the molecular mechanisms mediating these long-term changes remain to be elucidated.

Recent evidence suggests that acute alcohol exposure can interfere directly with CRH promoter activity to alter CRH gene transcription (Li, Kang et al. 2005). For example, Li et al., showed that alcohol decreased forskolin-induced increase in CRH promoter activity possibly by interfering at the cAMP response element (CRE) site in the NO108-15 cell line (Li, Kang et al. 2005). In addition, recent evidence also suggests that EtOH can alter the DNA status (Pandey, Ugale et al. 2008) or glucocorticoid response element (GRE):DNA binding in different brain regions, including cortex and hippocampus, due to chromatin remodelling (Roy, Mittal et al. 2002), raising the possibility that epigenetic mechanisms might underlie the EtOH-induced long-term changes in CRH and AVP gene expression. Histone deacetylases (HDAC) have the ability to remove acetyl groups off the chromatin making DNA more dense and unavailable for transcriptional machinery (Grunstein 1997). Interestingly, Pandey et al. showed that HDAC activity was decreased following acute EtOH exposure (single 1g/kg injection of EtOH), yet increased after chronic EtOH exposure (15 days of 9% EtOH liquid diet) in adult animals (Pandey, Ugale et al. 2008). One possibility is that binge-pattern EtOH exposure during puberty induces remodelling of the chromatin surrounding the CRH and/or AVP genes thereby permanently altering the access of transcriptional regulators for these gene promoters.

To my knowledge this is the first study showing the effects of adolescent binge EtOH exposure on adult HPA axis reactivity, however other reports have

demonstrated that pubertal EtOH exposure has long lasting effects on a variety of other CNS systems and brain regions, including the mesolimbic dopaminergic and glutaminergic system (Pascual, Boix et al. 2009), hippocampus, and cerebellum (Pascual, Blanco et al. 2007). Such changes in the CNS are often manifested by altered adult behaviour patterns (Maldonado-Devincci, Badanich et al.; Pascual, Blanco et al. 2007; Pascual, Boix et al. 2009). For example, Pascual et al. showed that 2 weeks of intermittent EtOH administration (single IP injection of 3g/kg EtOH for two consecutive days, followed by 2 day rest, then followed again by 2 days of EtOH injections) caused an increase in voluntary EtOH consumption in adult animals (Pascual, Boix et al. 2009). In a different study, they also showed that this intermittent pattern of EtOH administration induced long lasting deficits in learning ability, as discerned by a decreased number of correct choices in conditional discrimination learning task, and a reduced ability to adapt to a challenging environment in adulthood in a narrow beam task (Pascual, Blanco et al. 2007). Our data showing parallel effects of peri-pubertal binge EtOH exposure to the effects of juvenile stressors on the adult HPA axis (Avital and Richter-Levin 2005) or juvenile/early puberty EtOH exposure on EtOH abuse in adulthood (Pascual, Boix et al. 2009) indicate that during the peri-pubertal period the HPA axis is still immature and extremely vulnerable to EtOH-induced insults (Zilberman, Tavares et al. 2003; McEvoy and Shand 2008).

Physiological parameters of HPA axis, such as CORT and neuropeptide levels, are markedly different in response to both acute and chronic stressors in

juvenile compared with adult animals, suggesting that an extensive maturational process occurs during the pubertal transition (Jankord, Solomon et al.; Romeo, Lee et al. 2004; Romeo, Bellani et al. 2006; Romeo and McEwen 2006; Laroche, 2009 #190; McCormick and Mathews 2007; Evuarherhe, Leggett et al. 2009; Evuarherhe, Leggett et al. 2009; Laroche, Gasbarro et al. 2009). Most striking is the observation that corticosterone and ACTH levels take much longer to return to baseline in juvenile compared to adult animals when subjected to a variety of stressful stimuli (Vazquez and Akil 1993; Romeo, Bellani et al. 2006). Further, juveniles have higher overall stress reactivity (Romeo, Bellani et al. 2006) and chronic stress during puberty has been shown to result in an exaggerated stress-induced CORT response in adulthood (Jankord, Solomon et al.; Isgor, Cecchi et al. 2003). My results are consistent with these observations, as our animals pre-exposed to binge-pattern EtOH had a similarly exaggerated response to a subsequent EtOH stressor during adulthood. It is important to note that there are some inconsistencies between studies depending on the type of stressor and the specific paradigm (i.e. homotypic vs. heterotypic, chronic vs. acute). Consequently, the effects of EtOH on the HPA axis during adolescence may not necessarily be reflective of other types of stressors. Nevertheless, these data contribute to the growing body of evidence that perturbations to the HPA axis during this critical period of pubertal development can potentially have long lasting consequences for the adult stress response.

We are confident that the effects observed here on the expression of the AVP mRNA are specific to changes in the population of cells located in the

pPVN, and not to the magnocellular region. First, our data are consistent with our previous report showing no changes in the AVP mRNA expression in SON, a region largely responsible for maintaining osmotic homeostasis (Przybycien-Szymanska, Rao et al. 2009). Second, our data are also consistent with other reports showing that EtOH induced changes only in AVP-expressing neurons located in the pPVN, and not mPVN (Silva, Paula-Barbosa et al. 2002). Finally, the diuretic effects of EtOH are rapid and transient, making it unlikely to contribute to long lasting changes in AVP expression in the PVN.

Binge alcohol consumption among adolescents is a fundamental problem and mood disorders among both young and adult populations are increasing, therefore elucidating the long lasting consequences of binge EtOH exposure during adolescence is critical for understanding the aetiology of certain mood disorders. In this study we have identified long lasting effects of binge pattern EtOH exposure during peri-puberty on the central regulators of the HPA axis, CRH and AVP, and on the adult stress response. We have shown that adults who were exposed to a binge-pattern of alcohol during pubertal development have increased stress responses after subsequent alcohol exposure.

Dysregulation of the HPA axis has been shown to be predictive of developing mood disorders however more experiments, such as introducing a novel stressor and measuring behavioural outcomes, are needed to determine if there is a direct link between binge-pattern alcohol exposure and the development of mood disorders. Overall, these data have identified yet another system and additional molecular targets that are affected long term by adolescent alcohol exposure and

may lead to better understanding of factors that regulate HPA axis maturation during pubertal development.

Chapter Six

FINAL DISCUSSION

Summary

Our current understanding of how binge alcohol consumption affects the developing adolescent brain is severely limited. To date, specific molecular and neuroendocrine markers that are activated by alcohol during puberty and long lasting consequences of this pattern of alcohol exposure during this critical time period of development have not been identified. Elucidating the neurobiological targets of EtOH resulting from a binge pattern of EtOH consumption during adolescence is critical for understanding the long-term molecular and behavioral consequences of binge EtOH exposure and potential mechanisms that may be involved in development of mental health disorders. Therefore, the major goal of studies presented herein was to investigate the long lasting effects of binge EtOH exposure during puberty on the sensitivity of adult HPA axis to EtOH exposures in adulthood, as well as short term effects of this pattern of EtOH exposure and possible molecular mechanisms involved in these effects. In addition, in these studies I sought to investigate potential mechanisms responsible for observed sex differences in EtOH induced alteration of the HPA axis.

Based on my data, I can conclude that my hypothesis, that in males, binge pattern EtOH exposure during pubertal development dysregulates functioning of

adult HPA axis and that this effect is caused by long lasting changes in the PVN expression of CRH and AVP during adolescence mediated by direct actions of EtOH at the level of the CRH promoter, has been supported. (see Table 4 for summary of major findings).

SUMMARY OF MAJOR FINDINGS

Chapter 2. Effects of binge alcohol exposure in adolescence

Males (PND 37-44):

- Binge EtOH INCREASED CRH and AVP mRNA in the PVN
- Acute and Binge ETOH INCREASED plasma CORT levels, habituation effect after binge

Females (PND 37-44)

- NO CHANGES in the CRH and AVP mRNA in the PVN after EtOH treatment
- Acute and Binge EtOH INCREASED plasma CORT levels, habituation effect after binge

Chapter 3. Molecular mechanisms behind alcohol effects

- 12.5 and 100 mM EtOH ↓ CRH promoter activity at 0.5 h
- 12.5 and 100 mM EtOH ↑ CRH promoter activity at 2.0 h
- An increase in the promoter activity at 2.0 h is dependant on the nGRE and CRE sites

Chapter 4. Mechanisms behind sex differences

Ch-treated females (PND 37-44)

- Binge EtOH ↓ CRH and AVP mRNA in the PVN
- Acute and binge EtOH ↑ plasma CORT levels, no habituation after binge

E₂-treated females (PND 37-44)

- NO CHANGES in the CRH and AVP mRNA after EtOH treatment
- habituation effect after binge EtOH exposure present

Chapter 5. Long lasting consequences of binge alcohol exposure during puberty

EtOH naïve males (PND 68-74)

- NO CHANGES in CRH mRNA levels in the PVN due to EtOH treatments
- Acute and Binge EtOH ↑ plasma CORT levels, habituation effect after binge EtOH exposure present

SUMMARY OF MAJOR FINDINGS c.d.**EtOH pre-exposed males (PND 68-74)**

- Acute EtOH in adulthood ↑ CRH and AVP mRNA in the PVN (as compared to EtOH naïve)
- Pubertal binge EtOH exposure ↓ basal plasma CORT levels (as compared to EtOH naïve)
- Pubertal binge EtOH exposure resulted in ENHANCED ↑ in plasma CORT after subsequent acute and binge EtOH exposures in adults
- No habituation effect after subsequent binge EtOH in adults

Table 4. *Summary of major findings.* Data compared to saline treated controls. In EtOH pre-exposed group data compared to EtOH naïve group.

Data presented in this report clearly show that binge pattern EtOH exposure during peri-pubertal development induces changes in CRH and AVP gene expression in the PVN, the main brain region responsible for coordinating stress responses, and circulating CORT levels. I showed that the effects of binge EtOH exposure are sexually dimorphic and that these sex differences are mediated by E₂. In peri-pubertal females, E₂ is responsible for maintaining basal levels of CRH and AVP mRNA in the PVN even after binge EtOH exposure and for the observed habituation effects after binge EtOH exposure. In addition, I showed that EtOH-nGRE-CRH DNA interaction disrupt normal glucocorticoid negative feedback exerted at the level of the CRH promoter in a PVN derived cell line. Lastly, I showed that the changes observed during peri-puberty are long lasting and result in dysregulation of functioning of adult HPA axis. Notably, in peri-pubertal male rats binge EtOH exposure increased CRH and AVP mRNA in the PVN in a permanent fashion and this permanent alteration in the HPA axis resulted in dysregulation of the HPA axis in adulthood. Normal maturation of the HPA axis that should occur during pubertal development was compromised by binge EtOH exposure during peri-puberty because binge EtOH exposure during this time period resulted in more sensitive/dysregulated HPA axis in adulthood. Based on these data, I can speculate that this long lasting binge-EtOH-exposure-induced HPA axis dysregulation may result in mood disturbances in adulthood and may lead to increased risk for developing mood disorders in adulthood.

Final considerations

Binge alcohol exposure and magnocellular PVN and SON systems

Although it was not possible to separate the parvocellular and magnocellular divisions of the PVN in my tissue microdissection sample preparations, I am confident that the EtOH-induced changes in the AVP expression in all experiments presented here, accurately reflect changes in the AVP-expressing neurons associated with regulation of the HPA axis, and not in those responsible for osmoregulation for the following reasons. First, I showed that there were no changes in the expression of the AVP mRNA in the SON, a region where AVP is primarily responsible for regulating fluid homeostasis, both in adolescent male and female rats as well as in adult male rats. Second, there was no effect of EtOH in either peri-pubertal or adult acute-treated groups and since fluid homeostasis is an immediate and not cumulative physiological response, any diuretic effect of EtOH would have been observed in the acutely treated groups. Third, if the effects of EtOH on the AVP expression were due to an osmoregulatory effect, I would have expected to see a significant increase in the AVP mRNA in the PVN of peri-pubertal females, as well as peri-pubertal and adult males. Fourth, the diuretic effects of EtOH are rapid and transient, making it unlikely to contribute to any long lasting changes in AVP expression in the PVN and finally, my data are in agreement with previous studies showing that there were no changes in AVP expression in the magnocellular division of the PVN 3.0 h after an acute EtOH administration (Ogilvie, Lee et al. 1997).

The only time when I observed binge EtOH exposure induced changes in the AVP mRNA in the SON were in ovariectomized peri-pubertal females replaced with Ch. In these females, binge EtOH exposure decreased the AVP mRNA expression in the SON. This effect could be explained in two ways. First, data showing decreased AVP mRNA in the SON is consistent with diuretic effects of EtOH on the AVP as the AVP is mostly known as antidiuretic hormone (ADH). This explanation is highly unlikely because of the reasons described in the previous paragraph. Second, based on previous reports, I can speculate that EtOH induced changes in the PVN could influence gene expression in the SON. EtOH could induce cell death in the PVN which would result in a decreased expression of AVP mRNA in the SON. This explanation is consistent with previous reports showing that the AVP mRNA in the SON is decreased following EtOH exposure but only in rats bearing PVN lesions (Ogilvie, Lee et al. 1997) and AVP is neuroprotective in a PVN derived neuronal cell line (H32) (Chen, Volpi et al. 2008; Chen, Liu et al. 2009). Addition of the AVP to the media was found to protect against serum starvation induced apoptotic cell death in these neurons (Chen, Volpi et al. 2008; Chen, Liu et al. 2009). EtOH induced cell death in the PVN could be responsible for a decrease in the AVP mRNA in the PVN in Ch-treated females. It is likely that this decrease in the AVP mRNA in the PVN resulted in a decrease in the AVP mRNA in the SON as the functions of these two nuclei have been shown to be linked (Ogilvie, Lee et al. 1997). The cooperation between both magnocellular and parvocellular AVP systems needs

to be further investigated in order to support this hypothesis even though this explanation at this moment seems to be most likely.

Overall, these data indicate that in intact peri-pubertal and adult animals EtOH induced changes in the PVN are not due to diuretic effects of EtOH on the magnocellular division of the PVN and are specific to regulation of the HPA axis.

Body weight changes after EtOH treatments.

In males treated with binge EtOH exposure during puberty and then again in adulthood, data showed that pubertal binge-pattern EtOH exposure retarded the rate of weight gain as compared to their saline treated counterparts. This effect persisted into adulthood and resulted in adult animals that were significantly smaller than controls. It is important to note that these animals did not lose weight, but rather gained at a slower pace. Interestingly, this weight gap persisted throughout the period of one month during which animals were undisturbed and throughout adult EtOH treatments which had no further effects on the growth rate of animals. This growth rate retardation could be explained by following reasons. First, it is well known that both animals and humans undergo a growth spurt during pubertal development marked by an increase in muscle and bone mass (Gregory, Greene et al. 1992; Soliman, Khadir et al. 1995; Mauras, Rogol et al. 1996; Schoenau 2006; Venken, Moverare-Skrtic et al. 2007; Pradidarcheep and Showpittapornchai 2009) . In these experiments, binge EtOH treatment occurred during puberty and possibly during the critical period for weight gain. Alcohol is known to decrease bone and muscle mass (Callaci,

Himes et al.; Elmali, Ertem et al. 2002; Lauing, Himes et al. 2008; Alvisa-Negrin, Gonzalez-Reimers et al. 2009; Callaci, Himes et al. 2009), therefore it is possible that if EtOH exposure occurred during pubertal maturation, it hindered muscle mass and possibly bone gain and resulted in a permanent decrease in body weight. This critical period hypothesis is consistent with the fact that in adult animals, not undergoing growth spurt, binge EtOH exposure did not further cause growth retardation. Second, it is also possible that EtOH effects on sex steroid hormones were involved in the weight gain retardation observed. T levels increase markedly during puberty (Huhtaniemi, Nevo et al. 1986; Delemarre-van de Waal, van Coeverden et al. 2002; Evuarherhe, Leggett et al. 2009; Pradidarcheep and Showpittapornchai 2009) and T increased muscle tone contributes to the weight gain during pubertal development (Soliman, Khadir et al. 1995; Schoenau 2006; Pradidarcheep and Showpittapornchai 2009). I showed in peri-pubertal male rats that binge EtOH exposure decreased plasma T levels (Przybycien-Szymanska, Rao et al. 2010). This EtOH-induced decrease in plasma T levels could contribute to the slower weight gain in male rats that were exposed to binge EtOH during puberty. This weight difference was not observed in any of my previous studies most likely due to the shorter experimental time period and a smaller number of animals per treatment group. Lastly, it is also possible that in pubertal animals, binge-EtOH-exposure-induced elevated CORT levels inhibited feeding behavior. It is well established that during stress, elevated plasma CORT levels inhibit feeding behavior and cause muscle wasting (Tomas, Munro et al. 1979; Sapolsky, Romero et al. 2000). Binge EtOH exposure by

cousing elevation in plasma CORT levels could contribute to permanent decrease in body weight possible due to decreased food intake and increased muscle wasting during the growth spurt of animals. Together, these data support the notion that puberty is extremely vulnerable to alcohol abuse and effects of binge drinking during this developmental period can not only be manifested at the level of the central nervous system, but also can potentially disrupt normal homeostatic metabolic processes.

Additional notes about the binge EtOH exposure paradigm

This binge EtOH exposure paradigm employed in all of the studies presented herein was very useful because it allowed us to distinguish the pharmacological effects of EtOH from the effects of other nonspecific stressors, such as handling and injections. A similar binge EtOH exposure paradigm has been previously shown to be reliable for testing the effects of alcohol using an exposure pattern that is typical for adolescents (Lauing, Himes et al. 2008) . In addition, it has been show that the IP injection of EtOH, employed in my paradigm, does not appear to result in significantly different BAC compared to oral gavage in adolescent Wistar rats (Walker and Ehlers 2009), therefore the IP route of administration has been chosen as the least stressful method.

Future Directions

Data presented herein add a substantial amount to our knowledge of consequences of alcohol exposure in adolescence, however, there are many more questions that remain unanswered.

First, a direct link between binge EtOH exposure in adolescence, dysregulation of the HPA axis in adulthood, and the development of mood disorders in adulthood needs to be established. In studies presented herein, I have identified long lasting effects of binge pattern EtOH exposure during peri-puberty on the central regulators of the HPA axis, CRH and AVP, and on adult stress response measured by plasma CORT levels. I have shown that adults who were exposed to a binge-pattern of EtOH during pubertal development have increased stress responses after subsequent EtOH exposure. Dysregulation of the HPA axis has been shown to be predictive of developing mood disorders however more experiments, such as introducing a novel stressor and measuring behavioural outcomes, are needed to determine if there is this direct link between binge-pattern EtOH exposure during puberty and the development of mood disorders in adulthood. In the future, I would like to measure anxiety-like behaviors in adult animals exposed to “binging” during puberty using a variety of behavioral methods, including elevated plus maze, light-dark box and open field test. I would also like to test whether animals pre-exposed to binge EtOH during peri-puberty are more sensitive to other types of stressors, for example restraint stress, by measuring their CORT responses and changes in CRH and AVP mRNA expression after the stressor. These data would not only give me a direct

and clear link between binge alcohol consumption in adolescence and increased risk for developing mood disorders in adulthood, but would also strengthen my argument that binge drinking during adolescence has detrimental consequences for proper maturation of the HPA axis.

Binge EtOH exposure has sex specific effects on the pubertal HPA axis. One very important question that still remains unanswered is whether females are protected from long lasting detrimental effects of binge EtOH exposure because they do not exhibit the same changes in gene expression as males or is EtOH exposure during puberty more detrimental for females. In the future, I would like to investigate the CRH and AVP mRNA expression in the PVN as well as changes in circulating CORT levels in adult females pre-exposed to binge EtOH during puberty and compare these changes with changes occurring in males. If binge EtOH exposure in peri-pubertal females also induces long lasting changes in functions of the HPA axis, the next step would be to investigate anxiety-like behaviors and responses to heterotypic stressors in these females. Results of these experiments would tell us if pubertal females are more susceptible to the detrimental effects of alcohol and they could lead us to a better understanding of the mechanisms behind these sex differences.

17 β -estradiol is partially responsible for sex differences in the responsiveness of pubertal HPA axis to binge EtOH exposure; however, it is not the only factor involved. In ovariectomized females replaced with Ch, there was a decrease in the CRH and AVP mRNA in the PVN and SON which is contrary to what was observed in intact peri-pubertal males. Further studies in

ovariectomized females replaced with other steroid hormones, for instance T or its metabolites need to be performed in order to better understand the mechanisms behind these sex differences. In these experiments, plasma CORT levels and PVN expression of CRH and AVP mRNA would be measured in ovariectomized females replaced with T or DHT and these effects would be compared to ovariectomized females replaced with E₂ or cholesterol. In addition to these *in vivo* experiments, to better understand the interactions between EtOH and sex steroid hormones, CRH promoter activity would also be measured after EtOH treatment in the presence of androgen receptor agonists.

I showed that EtOH-GR signaling is responsible for the EtOH-induced increase in CRH promoter activity and possibly CRH mRNA expression in the PVN, although it is still not clear what causes a decrease in the promoter activity at the 0.5 h time point, as GR antagonist treatment and deletion of specific GR binding sites within nGRE site did not abolish this decrease. I would like to investigate EtOH-induced changes in upstream signaling molecules and changes in early response genes as these may be involved in this initial decrease in the promoter activity. Some possible target molecules may be kinases that affect cAMP signaling (PKA) or small ubiquitin-related modifiers (SUMO) that may affect GR induced changes in the CRH promoter activity and gene transcription. For example, it has been shown that SUMO-1 can increase the GR stability and increase GR transcriptional activity (Le Drian, Mincheneau et al. 2002) therefore the effects of EtOH on SUMO need to be investigated. We also need to investigate the interaction of EtOH with GABA signaling using EtOH treatment in

the presence of GABA receptor agonists and antagonists as GABAergic inputs to the PVN are major inhibitory inputs to the PVN (Cole and Sawchenko 2002). It is possible that at the 0.5 h time point, EtOH strengthens this GABA inhibition and results in decreased CRH promoter activity. Another possibility is that AVP mediates the decrease in CRH promoter activity at the 0.5 h time point. It has been shown that a rapid and local release of AVP has an inhibitory tone on the HPA axis and this effect is mediated through AVP R1 (Wotjak, Kubota et al. 1996). Therefore, it is possible that EtOH affects AVP receptors to inhibit CRH promoter activity. I would like to investigate the effects of EtOH in the presence of AVP, AVP receptors and AVP R agonist and antagonist to test for possible interactions between AVP and EtOH on the CRH promoter.

To strengthen my hypothesis that EtOH interferes with GR:DNA binding, I would also like to investigate these interactions in the presence and absence of EtOH *in vivo* and *in vitro* using chromatin immunoprecipitation assay (ChIP). Even though it has been shown *in vivo*, that EtOH decreases GR-DNA binding in the hippocampus (Roy, Mittal et al. 2002), this effect needs to be confirmed in the PVN derived cells. If there was a decrease in the GR-CRH DNA binding after EtOH treatment in both *in vitro* and *in vivo*, this would confirm my hypothesis that EtOH induced increase in CRH promoter activity is mediated by EtOH induced decrease in GR-CRH DNA binding.

My *in vitro* data describe mechanisms involved in EtOH-induced changes in the CRH promoter activity and potentially CRH mRNA. In addition to CRH, my *in vivo* data identified yet another target of EtOH actions in the PVN, which is

AVP. It would be important in the future to investigate molecular mechanisms behind EtOH effects on this neuropeptide as they may be different from the mechanisms described for CRH. Time course experiments would need to be performed in order to investigate if EtOH can directly modulate AVP promoter activity and if yes, it would be important to investigate effects of EtOH on AVP promoter activity in AVP promoter lacking specific regulatory sites. It is possible that mechanisms behind EtOH-induced changes in the AVP mRNA are different from mechanisms responsible for changes in the CRH mRNA, however, it is very likely that EtOH exerts similar effects on this promoter as the AVP promoter also contains GRE site and CRE site and is regulated at these sites in the same way as the CRH promoter (Iwasaki, Oiso et al. 1997; Kim, Summer et al. 2001; Yoshida, Iwasaki et al. 2006).

Take Home Message

My data clearly show that binge EtOH exposure has detrimental consequences for the adult HPA axis. Even though more experiments need to be performed in order to support this conclusion, binge alcohol consumption in adolescence may lead to increased risk for developing mood disorders in adulthood.

CHAPTER SEVEN

GENERAL METHODS

Animals

Male and female Wistar rats were purchased from Charles River Laboratories (Wilmington, MA) at weaning (post natal day (PND) 23) and allowed to acclimate to the new environment for several days after arrival. Pre-pubertal females on PND 26, were bilaterally ovariectomized and replaced with silastic capsules containing either 17 β -estradiol (E₂) or cholesterol (Ch). On PND 30, animals were handled 5 min/day for 7 days. EtOH treatments begun on PND 37. Animals were housed on a 12 h light 12 h dark cycle with lights on at 07.00h. Food and water were available *ad libitum* and all procedures were approved by the Loyola University Medical Center Institutional Animal Care and Use Committee (IACUC).

Binge Exposure Paradigm.

After one week of handling, animals were divided into one of 4 groups and begun the following treatments: 1) **UNTREATED** 2) **SALINE ONLY** (intraperitoneal (ip) saline injection once/day for 8 days), 3) **ACUTE EtOH** (saline injection once/day for 7 days; one 3g/kg EtOH injection on day of sacrifice), 4) **BINGE EtOH** (intraperitoneal (IP) 20% (v/v in saline) (Fig 2) EtOH injection every morning at 10:00 AM for 3 consecutive days, followed by 2 days of saline

injections, and then injected for additional 3 days with EtOH). A similar binge exposure paradigm has been used previously to mimic the pattern of binge EtOH consumption in adolescents (Lauing, Himes et al. 2008). It has been shown that this route of EtOH administration does not yield statistically different BAC compared to oral gavage (Walker and Ehlers 2009).

Importantly, the animals were given EtOH in the morning. Previous studies showed that morning EtOH administration does not interfere with normal feeding behaviour and does not result in body weight differences between EtOH-treated and control animals, thus eliminating the need for pair-fed controls (Lauing, Himes et al. 2008; Przybycien-Szymanska, Rao et al. 2009). On the last day of pubertal or adult treatments, one hour after the injection, animals were sacrificed by decapitation under Halothane anesthesia and trunk blood and brains were collected.

Blood alcohol concentration (BAC) measurements:

Trunk blood samples were collected into heparinised tubes, centrifuged at 3000 rpm for 10 min. at 4°C; and plasma stored at -20°C. Blood alcohol levels were determined by measuring the change in absorbance at 340 nm following enzymatic oxidation of EtOH to acetylaldehyde (Point Scientific Alcohol Reagent Kit). Assay range is 0 to 400 mg/dl and intra and interassay CV = 8.9% and 7.86%, respectively.

Hormone measurements:

Blood samples were collected into heparinized tubes, centrifuged at 3000 rpm for 10 min at 4°C and plasma stored at -20°C. For the testosterone (T) EIA kit, the range of detection was between 3.9 – 500 pg/ml and for the estradiol (E₂) kit the range of detection was 8.6 – 4000 pg/ml.

In intact peri-pubertal males and females plasma levels of testosterone (T) and E₂ were measured using commercially available EIA kit (Cayman Chemical Company, Ann Arbor, MI), respectively, according to manufacturer's instructions. In ovariectomized females replaced either with Ch or E₂, plasma E₂ levels were measured by Endocrine Technology and Support Laboratory at the Oregon National Primate Center at the Oregon Health Science University (Portland, OR) where E₂ Extraction-Chromatography-RIA was performed by Dr. K.-Y. Francis Pau and colleagues. For E₂ RIA reported intraassay and interassay CVs were 12% and 18%, respectively.

To measure CORT, ³I-CORT (PerkinElmer, Waltham, MA) and rabbit CORT antiserum (MP Biomedicals, Solon, OH) were used to perform RIA. On the first day of the procedure, a standard curve was prepared using CORT-standards (4-PREGNEN, 11b, 21-DIOL-3,20-DIONE-Steraloids, Inc). Appropriate sample tubes were filled with 100 µl of a sample, 100 µl of antibody solution (in 0.1% gel PBS), and 100 µl diluted radioactive tracer (10-12000 cpm). Tubes were incubated overnight at 4°C. On the second day, all tubes were filled with 100 µl of 0.5% gel PBS, 1 ml Dextran-Coated Charcoal (DCC), and 1.0 ml 0.01 M PBS. Samples were centrifuged at 3000 rpm at 4°C for 15 min and the

supernatant was collected into scintillation vials. Radioactivity was measured in each vial for 3 min. using Packard liquid scintillation counter. Levels of CORT in unknown samples were interpolated based on the standard curve. Intra and interassay CV were 4.96% and 7.93%, respectively.

To measure ACTH levels, ^{125}I -ACTH (DIASORIN, Stillwater, MN), rabbit IgG-ACTH-I primary antibody (Ig Corp, Nashville, TN) and goat anti-rabbit G-globulin secondary antibody (CalBiochem, San Diego, CA) were used to perform RIA. On the first day of the procedure, a standard curve was prepared using ACTH stock-human (1-39) obtained from BACHEM (Torrance, CA). Appropriate sample tubes were filled with 90 or 50 μl of BSA Buffer (0.01M Phosphate Buffer Saline (PBS), 0.15 M NaCl, 1% BSA, 0.15% Triton-X-100, 250 KIU/ml Aprotinin, pH7.6), 10 or 50 μl of sample for high and low hormone concentration measurements, respectively and 100 μl of primary antibody solution (20 μl IgG-ACTH-I primary antibody in 100 ml of EDTA buffer (0.01 M PBS, 0.15 M NaCl, 0.05 M EDTA, 1% normal rabbit serum, 2.6 ml Aprotinin, pH7.6)). Tubes were incubated for 24.0 h at 4°C. On a second day, tubes were filled with 100 μl diluted radioactive tracer (2000 cpm \pm 10%), gently vortexed and incubated for 72.0 h at 4°C. On the third day of the assay, 100 μl of goat anti-rabbit G-globulin secondary antibody solution (1:20 dilution in 0.01 M PBS buffer (0.15 M NaCl, pH 7.6) was added to each tube, except for tubes containing tracer alone (total radioactivity tubes) and incubated at 4°C for 16.0 h. On the fourth day, 1.5 ml of 0.01 M PBS was added to each tube (except total radioactivity tubes) and tubes were centrifuged for 40 min at 3000 rpms at 4°C. Supernatant was decanted and

radioactivity was counted for 5.0 min using gamma counter and levels of ACTH in unknown samples were interpolated based on the standard curve. Intra and interassay CV were 4.94% and 14.6 %, respectively.

Tissue collection and qRT-PCR:

After sacrifice, brains were rapidly collected and frozen using isopentane and stored at -80°C until further processing. Tissue collection and qRT-PCR were performed as previously reported (Przybycien-Szymanska, Rao et al. 2009). Briefly, frozen brains were sectioned at 200 µm on a freezing microtome and the paraventricular (PVN) and supraoptic (SON) nuclei were microdissected using a 0.75 mm Palkovit's brainpunch tool (Stoelting Co., Wood Dale, IL). The specificity of the microdissected regions was confirmed using The Rat Brain in Stereotaxic Coordinates, Fourth Edition Atlas (G. Paxinos and C. Watson). The PVN was microdissected taking an 0.75 mm area on each side of the third ventricle between 0.8 mm and 2.12 mm posterior to Bregma 8 mm below the top of the brain (Smith, Gardiner et al. 2008) (see Fig 33 for schematic localization of the PVN). The SON was microdissected taking a 0.4 mm area 9.5 mm below the top of the brain between 0.8 mm and 3.14 mm posterior to Bregma. Total RNA isolation was performed on sonicated tissue samples using Trizol reagent (Invitrogen Inc., Carlsbad, CA) according to the manufacture's directions. Following RNA isolation, 0.5 µg total RNA was reverse transcribed using the First Strand Synthesis SuperMix for qRT-PCR (Invitrogen Inc., Carlsbad, CA). Roche FastStart SYBR Green Master Mix was added to intron-spanning AVP specific

upper and lower AVP primer (0.25 μ M final concentration; 5-GGGCAGGTAGTTCTCCTCCT; 5-CACCTCTGCCTGCTACTTCC) and intron-spanning CRH primer (0.25 μ M final concentration; 5-GAGAAAGGGGAAAGGCAAAG; 5-ATCAGAATCGGCTGAGGTTG). Then, 2 μ L cDNA templates were added to duplicate reactions performed in 96 well plates. Quantification of the target gene expression was achieved by extrapolating from standard curve of known concentrations of AVP or CRH run simultaneously in the same plate. All samples were normalized to the hypoxanthine guanine phosphoribosyl transferase 1 (HPRT) housekeeping gene, as it is not altered by EtOH treatment (Przybycien-Szymanska, Rao et al. 2009).

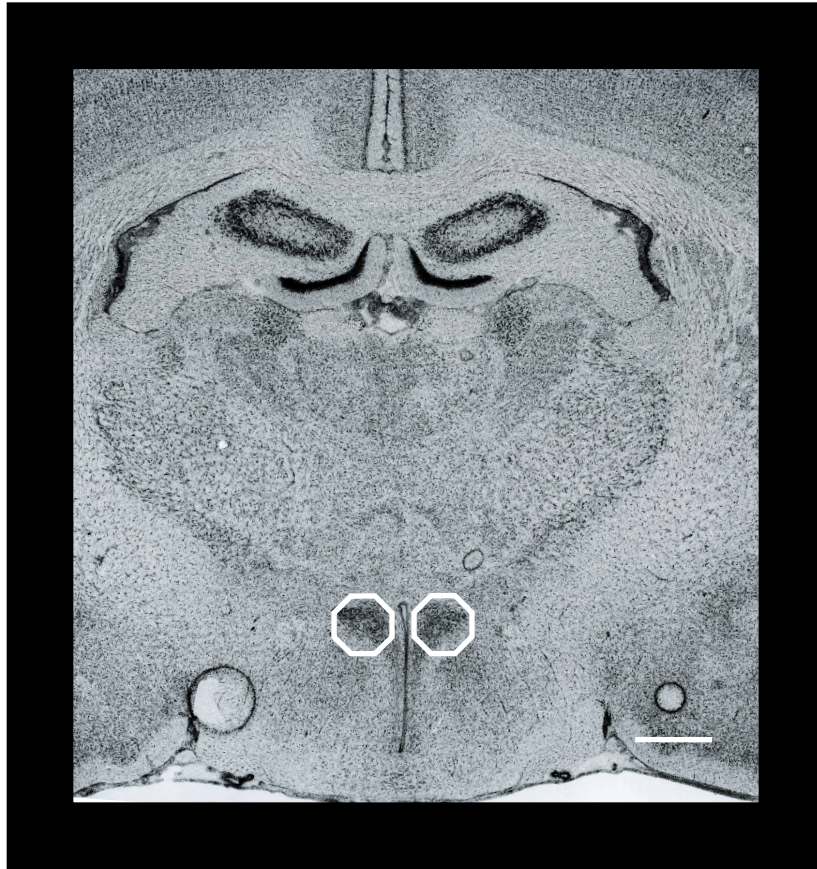

Fig 33. Representative diagram depicting the brain area microdissected (circle) for the PVN. Scale Bar = 1mm. Adjusted from *The Rat Brain in Stereotaxic Coordinates*, Fourth Edition Atlas (G. Paxinos and C. Watson).

qRT-PCR for GR expression in IVB cells

GR gene expression levels were measured in IVB cells after EtOH treatment. Cells were plated at the density of 200,000 cells/well in clear 6-well plate until they achieved final confluence of 90%. At that time (approximately 72.0 h later) cells were treated with 100 mM EtOH or vehicle for 0.5 or 2.0 h. After appropriate treatment times, cells were washed 2 times with cold PBS and 1 ml of Trizol was added to each well. Total RNA isolation was performed on sonicated samples using Trizol reagent (Invitrogen Inc., Carlsbad, CA) according to the manufacturer's directions. Following RNA isolation, 0.5 µg total RNA was reverse transcribed using the First Strand Synthesis SuperMix for qRT-PCR (Invitrogen Inc., Carlsbad, CA). Roche FastStart SYBR Green Master Mix was added to GR specific upper and lower primer (0.25 µM final concentration; 5-AAACCTCAATAGGTGCGACCAGCGT; 5-AGGTGCTTTGGTCTGTGGGATACA). Then, 2 µL cDNA templates were added to duplicate reactions performed in 96 well plates. Quantification of the target gene expression was achieved by extrapolating from standard curve of known concentrations of the hypoxanthine guanine phosphoribosyl transferase 1 (HPRT) housekeeping gene run simultaneously in the same plate. All samples were normalized to the HPRT housekeeping gene, as it is not altered by EtOH treatment (Przybycien-Szymanska, Rao et al. 2009).

Cell Culture

The IVB cell line, derived from the rat hypothalamic PVN, was used for all transient transfections (generously provided by Dr. John Kaskow, University of

Cincinnati) and was verified to be free of mycoplasma contamination (data not shown, MycoSensor QPCR, Stratagene/Agilent Technologies). Cells were maintained in DMEM containing 4.5% glucose and L-glutamine (HyClone Laboratories, Logan, UT) supplemented with 10% fetal bovine serum. Cells were grown to 90% confluence and all transient transfections were performed within 10 passages.

Reporter gene constructs and expression vectors

The full-length CRH promoter was generously provided and validated by Dr. Audrey F. Seasholtz (University of Michigan, Ann Arbor, MI) and then modified as follows. The full-length promoter fragment (-2125/+94) was excised from the pUC18 vector by restriction enzyme digestion for EcoR1 (5') and HINDIII (3') and subsequently subcloned into the promoterless luciferase vector (pGL3 basic, Promega Corp., Madison, WI). The pRL-tk-luciferase reporter vector (Promega Corp., Madison, WI) was used as an internal control for calculating plasmid transfection efficiency.

Transient Transfections and Dual Luciferase Assay:

Cells were plated at the density of 20,000 cells/well in opaque 96-well plate for 24 hours prior to transfection to achieve a final confluence of 70-90%. Transient transfections were performed in replicates of 6 wells/plate for each construct/treatment and each assay was repeated minimum of 6 times (N=6). Transfections were achieved using a lipid-mediated transfection reagent,

Fugene6 (Roche Molecular Biomedical, Indianapolis, IN) according to manufacturer's instructions. Twenty-four hours following transfection, cells were treated (see below) and then processed for luciferase assays (Dual Luciferase Reporter (DLR) kit (Promega Inc., Madison, WI). Briefly, cells were lysed in 20 μ l of lysis buffer, incubated on a shaker for 20 min at room temperature and then loaded into a multiple well plate reader (Synergy HT, Biotech). The plate reader is equipped with dual injectors and automatically dispensed 100 μ l firefly luciferase substrate (LARII) followed by "stop-and-glo" substrate for renilla luciferase. Results were analyzed using Gen5 software (Biotech Inc., Winooski, VT).

EtOH and Hormone Treatments

Twenty-four hours after transfection with the CRH promoter, cells were incubated with varying concentrations of EtOH (12.5, 25.0, 50.0 or 100 mM) diluted in 10% FBS media (vehicle) for 2.0 h (dose response), or they were treated with 100 mM EtOH for either 0.5, 1.0, 2.0 or 4.0 h (time course). Cells transfected with the mutated CRH promoter that lacked specific GR regulatory regions were treated with 12.5 mM EtOH or vehicle for 2.0 h or, in control experiments, they were treated with 25 μ M Forskolin for 6.0 h. In another set of experiments, 8.0 h after transfections with WT CRH promoter, cells were incubated in 10 nM E₂ or vehicle. 16.0 h after hormone treatments, cells were treated with 10 nM E₂ in the presence or absence of 100 mM EtOH for 2.0 h.

The glucocorticoid receptor (GR) antagonist, RU486, was used in cell culture in the presence of EtOH in order to test if GRs are involved in EtOH

effects on the CRH promoter. RU486 antagonistic properties are achieved by corepressor recruitment to the GR-DNA complex and inhibition of gene transcription. It has been shown that in the presence of RU486 DNA binding to GR still occurs but when RU486 is in a bound state, protein named nuclear corepressor (NCoR) is recruited to the N terminus of the GR and the DNA transcription is prevented. (Rajpert, Lemaigre et al. 1987; Schulz, Eggert et al. 2002). 8.0 h after transfections with WT CRH promoter, cells were incubated in 100nM RU or vehicle. 16.0 h after hormone treatments, cells were treated with 100nM RU486 in the presence or absence of 100 mM EtOH for 0.5, 1.0, 2.0 or 4.0 h.

Site-Directed Mutagenesis.

Scanning mutagenesis deletions were performed on the CRH promoter using the QuickChange II XL kit according to manufacturer's instructions (Stratagene, LaJolla, CA). Briefly, forward and reverse primer sequences were designed targeting the appropriate identified regions of the promoters (GR 1, (5'-CTTGGATAATCTCATTCAAGAACAATGGACAAGTCATAAGAGC-3'; 5'-GAACCTATTAGAGTAAGTTCTTGTTACCTGTTTCAGTATTCTTCG-3') GR 2 (5'-CTCATTCAAGAATTTTTGTCAACAAGTCATAAGAAGCCCTTCCA-3'; 5'-GAGTAAGTTCTTAAAAACAGTTGTTTCAGTATTCTTCGGGAAGGR-3'), GR 3 (5'-TTTGTCAATGGACAAGTCAGCCCTTCCATTTTAGGG-3'; 5'-AAACAGTTACCTGTTTCAGTCGGGAAGGTAAAATCCC-3'), GR1 and 2 double deletion (5'-GGATAATCTCATTCAAGAACAAGTCATAAGAAGCCCTTCCA-3';

5'TGGAAGGGCTTCTTATGACTTTGTTCTTGAATGAGATTATCC-3' or CRE deletion (5'-CTTCCATTTTAGGGCTCGTTCCAAGGAGGCGATAA-3'; 5'-TTATCGCCTCCTTGGAACGAGCCCTAAAATGGAAG-3')). Sequences contained deletions of 7, 4, 6, 11 or 7 bp, respectively sequentially from 5' to 3' in these regions (Fig 12). A standard PCR reaction was performed on a thermal cycler using mutated CRH-luciferase construct as a template. Following the reaction, the parent plasmid was digested using the DpnI restriction enzyme and the daughter plasmid, containing the desired mutation was transformed into XL-10 Ultragold competent cells and amplified. The mutation was confirmed by DNA sequencing using the in-house core sequencing facility (Loyola University Chicago, Stritch School of Medicine).

In Vitro Toxicology Assay (MTT based)

Cell viability was measured using *in vitro* 3-(4,5-Dimethylthiazol-2-yl)-2,5-diphenyltetrazolium bromide) MTT based Toxicology assay (Sigma-Aldrich) according to manufacturer's instructions. Briefly, following EtOH treatments cells were washed once with sterile PBS and media was replaced with 250 µl of a 0.25 mg/ml solution of MTT in regular growth media without FBS and phenol red. Cells were incubated in the MTT solutions for 1.5 h at 37^o C; then MTT solution was removed. MTT solubilization solution (200 µl of 0.04 M HCl in absolute isopropanol) was added to each sample and transferred to 96-well plate. Absorbance was read at 570 nm on a multimode multiplate reader (Biotech Inc., Winooski, VT).

Statistical Analysis

For most data, one-way ANOVA was used to test for differences between specific treatment groups followed by Tukey post-hoc test if one-way achieved significance. Student's t-test was used in order to compare differences between vehicle and EtOH treatment within each deletion mutation.

Two-way ANOVA was used to test for interactions between pubertal and adult treatments and for main effects of these treatments in regards to following dependent variables: plasma BAC, plasma CORT levels, CRH mRNA in the PVN and AVP mRNA in the PVN and in the SON. Tukeys post hoc test was used if ANOVA achieved significance. If ANOVA showed interactions between treatments, students t-tests were used to asses significance between EtOH and saline pre-exposed groups within specific adult EtOH treatments.

Two-way ANOVA was also used to test for interactions between Ch and E₂ treatments and for main effects of these treatments in regards to following dependent variables: plasma BAC, plasma ACRH and CORT levels, CRH mRNA in the PVN and AVP mRNA in the PVN and in the SON. Tukeys post hoc test was used if ANOVA achieved significance. If ANOVA showed interactions between treatments, students t-tests were used to asses significance between Ch and E₂ treatments within specific saline or EtOH treatments. All tests were performed using SigmaStat Statistical Analysis Software. A p-value of less than 0.05 was considered to be significant.

REFERENCES

- Aguilera, G., J. P. Harwood, et al. (1983). "Mechanisms of action of corticotropin-releasing factor and other regulators of corticotropin release in rat pituitary cells." J Biol Chem **258**(13): 8039-45.
- Aguilera, G. and C. Rabadan-Diehl (2000). "Regulation of vasopressin V1b receptors in the anterior pituitary gland of the rat." Exp Physiol **85 Spec No**: 19S-26S.
- Ahmed, E. I., J. L. Zehr, et al. (2008). "Pubertal hormones modulate the addition of new cells to sexually dimorphic brain regions." Nat Neurosci **11**(9): 995-7.
- Akbar, M., J. Baick, et al. (2006). "Ethanol promotes neuronal apoptosis by inhibiting phosphatidylserine accumulation." J Neurosci Res **83**(3): 432-40.
- Albeck, D. S., C. R. McKittrick, et al. (1997). "Chronic social stress alters levels of corticotropin-releasing factor and arginine vasopressin mRNA in rat brain." J Neurosci **17**(12): 4895-903.
- Allen, C. D., C. L. Rivier, et al. "Adolescent alcohol exposure alters the central brain circuits known to regulate the stress response." Neuroscience.
- Aloe, L. (2006). "Alcohol intake during prenatal life affects neuroimmune mediators and brain neurogenesis." Ann Ist Super Sanita **42**(1): 17-21.
- Altman, J. and S. A. Bayer (1986). "The development of the rat hypothalamus." Adv Anat Embryol Cell Biol **100**: 1-178.
- Alvisa-Negrin, J., E. Gonzalez-Reimers, et al. (2009). "Osteopenia in alcoholics: effect of alcohol abstinence." Alcohol Alcohol **44**(5): 468-75.
- Andrews, W. W., J. P. Advis, et al. (1980). "The first proestrus in the female rat: circulating steroid levels preceding and accompanying the preovulatory LH surge." Proc Soc Exp Biol Med **163**(3): 305-9.
- Arborelius, L., M. J. Owens, et al. (1999). "The role of corticotropin-releasing factor in depression and anxiety disorders." J Endocrinol **160**(1): 1-12.

- Avital, A. and G. Richter-Levin (2005). "Exposure to juvenile stress exacerbates the behavioural consequences of exposure to stress in the adult rat." Int J Neuropsychopharmacol **8**(2): 163-73.
- Azcoitia, I., A. Sierra, et al. (2001). "Brain aromatase is neuroprotective." J Neurobiol **47**(4): 318-29.
- Bacon, S. J. and A. D. Smith (1988). "Preganglionic sympathetic neurones innervating the rat adrenal medulla: immunocytochemical evidence of synaptic input from nerve terminals containing substance P, GABA or 5-hydroxytryptamine." J Auton Nerv Syst **24**(1-2): 97-122.
- Baldwin, D. and S. Rudge (1995). "The role of serotonin in depression and anxiety." Int Clin Psychopharmacol **9 Suppl 4**: 41-5.
- Bale, T. L., A. M. Davis, et al. (2001). "CNS region-specific oxytocin receptor expression: importance in regulation of anxiety and sex behavior." J Neurosci **21**(7): 2546-52.
- Becker, J. B., L. M. Monteggia, et al. (2007). "Stress and disease: is being female a predisposing factor?" J Neurosci **27**(44): 11851-5.
- Bielsky, I. F., S. B. Hu, et al. (2004). "Profound impairment in social recognition and reduction in anxiety-like behavior in vasopressin V1a receptor knockout mice." Neuropsychopharmacology **29**(3): 483-93.
- Blanchard, R. J., G. Griebel, et al. (2005). "AVP V1b selective antagonist SSR149415 blocks aggressive behaviors in hamsters." Pharmacol Biochem Behav **80**(1): 189-94.
- Blevins, T., T. Mirshahi, et al. (1997). "Effects of acute and chronic ethanol exposure on heteromeric N-methyl-D-aspartate receptors expressed in HEK 293 cells." J Neurochem **69**(6): 2345-54.
- Blier, P. (2001). "Crosstalk between the norepinephrine and serotonin systems and its role in the antidepressant response." J Psychiatry Neurosci **26 Suppl**: S3-10.
- Bodo, C. and E. F. Rissman (2006). "New roles for estrogen receptor beta in behavior and neuroendocrinology." Front Neuroendocrinol **27**(2): 217-32.
- Cagnacci, A., R. Zanin, et al. (2007). "Menopause, estrogens, progestins, or their combination on body weight and anthropometric measures." Fertil Steril **88**(6): 1603-8.
- Callaci, J. J., R. Himes, et al. "Long-term modulations in the vertebral transcriptome of adolescent-stage rats exposed to binge alcohol." Alcohol Alcohol **45**(4): 332-46.

- Callaci, J. J., R. Himes, et al. (2009). "Binge alcohol-induced bone damage is accompanied by differential expression of bone remodeling-related genes in rat vertebral bone." Calcif Tissue Int **84**(6): 474-84.
- Camarillo, C. and R. C. Miranda (2008). "Ethanol exposure during neurogenesis induces persistent effects on neural maturation: evidence from an ex vivo model of fetal cerebral cortical neuroepithelial progenitor maturation." Gene Expr **14**(3): 159-71.
- Cannon, D. M., M. Ichise, et al. (2007). "Elevated serotonin transporter binding in major depressive disorder assessed using positron emission tomography and [11C]DASB; comparison with bipolar disorder." Biol Psychiatry **62**(8): 870-7.
- Cao, W. H. and S. F. Morrison (2001). "Differential chemoreceptor reflex responses of adrenal preganglionic neurons." Am J Physiol Regul Integr Comp Physiol **281**(6): R1825-32.
- Cardona-Gomez, G. P., P. Mendez, et al. (2001). "Interactions of estrogens and insulin-like growth factor-I in the brain: implications for neuroprotection." Brain Res Brain Res Rev **37**(1-3): 320-34.
- Chen, J., Y. Liu, et al. (2009). "Antiapoptotic effects of vasopressin in the neuronal cell line H32 involve protein kinase Calpha and beta." J Neurochem **110**(4): 1310-20.
- Chen, J., S. Volpi, et al. (2008). "Anti-apoptotic actions of vasopressin in H32 neurons involve MAP kinase transactivation and Bad phosphorylation." Exp Neurol **211**(2): 529-38.
- Choi, I. Y., S. Lee, et al. (2008). "Novel role of adrenergic neurons in the brain stem in mediating the hypothalamic-pituitary axis hyperactivity caused by prenatal alcohol exposure." Neuroscience **155**(3): 888-901.
- Chu, J., M. Tong, et al. (2007). "Chronic ethanol exposure causes mitochondrial dysfunction and oxidative stress in immature central nervous system neurons." Acta Neuropathol **113**(6): 659-73.
- Clark, T. P. and R. J. Kemppainen (1994). "Glucocorticoid negative feedback in sheep corticotrophs: a comparison with AtT-20 corticotroph tumor cells." Am J Physiol **267**(2 Pt 2): R463-9.
- Cole, R. L. and P. E. Sawchenko (2002). "Neurotransmitter regulation of cellular activation and neuropeptide gene expression in the paraventricular nucleus of the hypothalamus." J Neurosci **22**(3): 959-69.
- Conway, K. P., W. Compton, et al. (2006). "Lifetime comorbidity of DSM-IV mood and anxiety disorders and specific drug use disorders: results from the

National Epidemiologic Survey on Alcohol and Related Conditions." J Clin Psychiatry **67**(2): 247-57.

- Csaki, A., K. Kocsis, et al. (2002). "Localization of putative glutamatergic/aspartatergic neurons projecting to the supraoptic nucleus area of the rat hypothalamus." Eur J Neurosci **16**(1): 55-68.
- Cunningham, E. T., Jr., M. C. Bohn, et al. (1990). "Organization of adrenergic inputs to the paraventricular and supraoptic nuclei of the hypothalamus in the rat." J Comp Neurol **292**(4): 651-67.
- Cunningham, M. G., S. Bhattacharyya, et al. (2002). "Amygdalo-cortical sprouting continues into early adulthood: implications for the development of normal and abnormal function during adolescence." J Comp Neurol **453**(2): 116-30.
- Dasen, J. S. and M. G. Rosenfeld (1999). "Signaling mechanisms in pituitary morphogenesis and cell fate determination." Curr Opin Cell Biol **11**(6): 669-77.
- De Vries, G. J., Z. Wang, et al. (1994). "Sex differences in the effects of testosterone and its metabolites on vasopressin messenger RNA levels in the bed nucleus of the stria terminalis of rats." J Neurosci **14**(3 Pt 2): 1789-94.
- Delemarre-van de Waal, H. A., S. C. van Coeverden, et al. (2002). "Factors affecting onset of puberty." Horm Res **57 Suppl 2**: 15-8.
- Dickstein, G., C. R. DeBold, et al. (1996). "Plasma corticotropin and cortisol responses to ovine corticotropin-releasing hormone (CRH), arginine vasopressin (AVP), CRH plus AVP, and CRH plus metyrapone in patients with Cushing's disease." J Clin Endocrinol Metab **81**(8): 2934-41.
- DonCarlos, L. L., I. Azcoitia, et al. (2009). "Neuroprotective actions of selective estrogen receptor modulators." Psychoneuroendocrinology **34 Suppl 1**: S113-22.
- Drevets, W. C., M. E. Thase, et al. (2007). "Serotonin-1A receptor imaging in recurrent depression: replication and literature review." Nucl Med Biol **34**(7): 865-77.
- Druse, M. J., A. Kuo, et al. (1991). "Effects of in utero ethanol exposure on the developing serotonergic system." Alcohol Clin Exp Res **15**(4): 678-84.
- Druse, M. J., N. Tajuddin, et al. (1990). "Effects of in utero ethanol exposure on the developing dopaminergic system in rats." J Neurosci Res **27**(2): 233-40.

- Druse, M. J., N. F. Tajuddin, et al. (2006). "The effects of ethanol and the serotonin(1A) agonist ipsapirone on the expression of the serotonin(1A) receptor and several antiapoptotic proteins in fetal rhombencephalic neurons." Brain Res **1092**(1): 79-86.
- Egashira, N., A. Tanoue, et al. (2007). "Impaired social interaction and reduced anxiety-related behavior in vasopressin V1a receptor knockout mice." Behav Brain Res **178**(1): 123-7.
- Eison, M. S. (1990). "Serotonin: a common neurobiologic substrate in anxiety and depression." J Clin Psychopharmacol **10**(3 Suppl): 26S-30S.
- Elmali, N., K. Ertem, et al. (2002). "Fracture healing and bone mass in rats fed on liquid diet containing ethanol." Alcohol Clin Exp Res **26**(4): 509-13.
- Engelmann, M., C. T. Wotjak, et al. (2000). "Behavioural impact of intraseptally released vasopressin and oxytocin in rats." Exp Physiol **85 Spec No**: 125S-130S.
- Epstein, E. E., K. Fischer-Elber, et al. (2007). "Women, aging, and alcohol use disorders." J Women Aging **19**(1-2): 31-48.
- Erkut, Z. A., C. Pool, et al. (1998). "Glucocorticoids suppress corticotropin-releasing hormone and vasopressin expression in human hypothalamic neurons." J Clin Endocrinol Metab **83**(6): 2066-73.
- Evuarherhe, O., J. Leggett, et al. (2009). "Reversal of the hypothalamo-pituitary-adrenal response to oestrogens around puberty." J Endocrinol **202**(2): 279-85.
- Evuarherhe, O., J. D. Leggett, et al. (2009). "Organizational role for pubertal androgens on adult hypothalamic-pituitary-adrenal sensitivity to testosterone in the male rat." J Physiol **587**(Pt 12): 2977-85.
- Figueiredo, H. F., B. L. Bodie, et al. (2003). "Stress integration after acute and chronic predator stress: differential activation of central stress circuitry and sensitization of the hypothalamo-pituitary-adrenocortical axis." Endocrinology **144**(12): 5249-58.
- Garcia-Segura, L. M., I. Azcoitia, et al. (2001). "Neuroprotection by estradiol." Prog Neurobiol **63**(1): 29-60.
- Garcia-Segura, L. M., A. Wozniak, et al. (1999). "Aromatase expression by astrocytes after brain injury: implications for local estrogen formation in brain repair." Neuroscience **89**(2): 567-78.
- Gibo, H., M. Hokama, et al. (1993). "[Arteries to the pituitary]." Nippon Rinsho **51**(10): 2550-4.

- Giedd, J. N., J. Blumenthal, et al. (1999). "Brain development during childhood and adolescence: a longitudinal MRI study." Nat Neurosci **2**(10): 861-3.
- Girotti, M., T. W. Pace, et al. (2006). "Habituation to repeated restraint stress is associated with lack of stress-induced c-fos expression in primary sensory processing areas of the rat brain." Neuroscience **138**(4): 1067-81.
- Gorman, J. M. and J. M. Kent (1999). "SSRIs and SNRIs: broad spectrum of efficacy beyond major depression." J Clin Psychiatry **60 Suppl 4**: 33-8; discussion 39.
- Goujon, E., S. Laye, et al. (1997). "Regulation of cytokine gene expression in the central nervous system by glucocorticoids: mechanisms and functional consequences." Psychoneuroendocrinology **22 Suppl 1**: S75-80.
- Green, J. L., J. P. Figueroa, et al. (2000). "Corticotropin-releasing hormone type I receptor messenger ribonucleic acid and protein levels in the ovine fetal pituitary: ontogeny and effect of chronic cortisol administration." Endocrinology **141**(8): 2870-6.
- Gregory, J. W., S. A. Greene, et al. (1992). "Effects of oral testosterone undecanoate on growth, body composition, strength and energy expenditure of adolescent boys." Clin Endocrinol (Oxf) **37**(3): 207-13.
- Grunstein, M. (1997). "Histone acetylation in chromatin structure and transcription." Nature **389**(6649): 349-52.
- Han, T. M. and G. J. De Vries (2003). "Organizational effects of testosterone, estradiol, and dihydrotestosterone on vasopressin mRNA expression in the bed nucleus of the stria terminalis." J Neurobiol **54**(3): 502-10.
- Handa, R. J., P. Corbier, et al. (1985). "Differential effects of the perinatal steroid environment on three sexually dimorphic parameters of the rat brain." Biol Reprod **32**(4): 855-64.
- Handa, R. J., M. J. Weiser, et al. (2009). "A role for the androgen metabolite, 5alpha-androstane-3beta,17beta-diol, in modulating oestrogen receptor beta-mediated regulation of hormonal stress reactivity." J Neuroendocrinol **21**(4): 351-8.
- Handa, R. J., R. T. Zoeller, et al. (2007). "Changes in vasoactive intestinal peptide and arginine vasopressin expression in the suprachiasmatic nucleus of the rat brain following footshock stress." Neurosci Lett **425**(2): 99-104.
- Hatton, G. I., P. Cobbett, et al. (1985). "Extranuclear axon collaterals of paraventricular neurons in the rat hypothalamus: intracellular staining,

immunocytochemistry and electrophysiology." Brain Res Bull **14**(2): 123-32.

Herman, J. P., N. K. Mueller, et al. (2004). "Role of GABA and glutamate circuitry in hypothalamo-pituitary-adrenocortical stress integration." Ann N Y Acad Sci **1018**: 35-45.

Herman, J. P., M. M. Ostrander, et al. (2005). "Limbic system mechanisms of stress regulation: hypothalamo-pituitary-adrenocortical axis." Prog Neuropsychopharmacol Biol Psychiatry **29**(8): 1201-13.

Herman, J. P., J. G. Tasker, et al. (2002). "Local circuit regulation of paraventricular nucleus stress integration: glutamate-GABA connections." Pharmacol Biochem Behav **71**(3): 457-68.

Hoffman, P. L. and J. R. Dave (1991). "Chronic ethanol exposure uncouples vasopressin synthesis and secretion in rats." Neuropharmacology **30**(11): 1245-9.

Hofmann, C. E., L. Ellis, et al. (2007). "Hypothalamic-pituitary-adrenal responses to 5-HT_{1A} and 5-HT_{2A/C} agonists are differentially altered in female and male rats prenatally exposed to ethanol." Alcohol Clin Exp Res **31**(2): 345-55.

Holsboer, F., C. J. Lauer, et al. (1995). "Altered hypothalamic-pituitary-adrenocortical regulation in healthy subjects at high familial risk for affective disorders." Neuroendocrinology **62**(4): 340-7.

Hou-Yu, A., A. T. Lamme, et al. (1986). "Comparative distribution of vasopressin and oxytocin neurons in the rat brain using a double-label procedure." Neuroendocrinology **44**(2): 235-46.

Hrabovszky, E., L. Deli, et al. (2007). "Glutamatergic innervation of the hypothalamic median eminence and posterior pituitary of the rat." Neuroscience **144**(4): 1383-92.

Huhtaniemi, I. T., N. Nevo, et al. (1986). "Effect of postnatal treatment with a gonadotropin-releasing hormone antagonist on sexual maturation of male rats." Biol Reprod **35**(3): 501-7.

Huppenbauer, C. B., L. Tanzer, et al. (2005). "Gonadal steroid attenuation of developing hamster facial motoneuron loss by axotomy: equal efficacy of testosterone, dihydrotestosterone, and 17-beta estradiol." J Neurosci **25**(16): 4004-13.

Ikin, J. F., M. C. Creamer, et al. "Comorbidity of PTSD and depression in Korean War veterans: prevalence, predictors, and impairment." J Affect Disord **125**(1-3): 279-86.

- Isgor, C., M. Cecchi, et al. (2003). "Estrogen receptor beta in the paraventricular nucleus of hypothalamus regulates the neuroendocrine response to stress and is regulated by corticosterone." Neuroscience **121**(4): 837-45.
- Isgor, C., K. R. Shieh, et al. (2003). "Colocalization of estrogen beta-receptor messenger RNA with orphanin FQ, vasopressin and oxytocin in the rat hypothalamic paraventricular and supraoptic nuclei." Anat Embryol (Berl) **206**(6): 461-9.
- Isobe, Y. and M. Isobe (1998). "Circadian rhythm of Arg-vasopressin contents in the suprachiasmatic nucleus in relation to corticosterone." Brain Res **800**(1): 78-85.
- Iwasaki, Y., Y. Oiso, et al. (1997). "Positive and negative regulation of the rat vasopressin gene promoter." Endocrinology **138**(12): 5266-74.
- Jankord, R., M. B. Solomon, et al. "Stress Vulnerability during Adolescent Development in Rats." Endocrinology **152**(2): 629-38.
- Jensen, C. F., T. W. Keller, et al. (1997). "Behavioral and neuroendocrine responses to sodium lactate infusion in subjects with posttraumatic stress disorder." Am J Psychiatry **154**(2): 266-8.
- Jorgensen, H., U. Knigge, et al. (2002). "Serotonergic stimulation of corticotropin-releasing hormone and pro-opiomelanocortin gene expression." J Neuroendocrinol **14**(10): 788-95.
- Kang, S. S., M. Cole, et al. (2004). "Development of individual alcohol inhalation chambers for mice: validation in a model of prenatal alcohol." Alcohol Clin Exp Res **28**(10): 1549-56.
- Kater, C. E., E. G. Biglieri, et al. (1982). "Regulation of the mineralocorticoid hormones in adrenocortical disorders with adrenocorticotropin excess." Clin Exp Hypertens A **4**(9-10): 1749-58.
- Kater, C. E., I. Irony, et al. (1990). "Continuous adrenocorticotropin administration in hypopituitarism produces asynchronous increases of deoxycorticosterone and 11-deoxycortisol relative to other reduced zona fasciculata steroids." J Clin Endocrinol Metab **71**(2): 305-10.
- Keck, M. E., T. Welt, et al. (2003). "Reduction of hypothalamic vasopressinergic hyperdrive contributes to clinically relevant behavioral and neuroendocrine effects of chronic paroxetine treatment in a psychopathological rat model." Neuropsychopharmacology **28**(2): 235-43.
- Kim, C. K., P. K. Giberson, et al. (1999). "Effects of prenatal ethanol exposure on hypothalamic-pituitary-adrenal responses to chronic cold stress in rats." Alcohol Clin Exp Res **23**(2): 301-10.

- Kim, J. A., R. A. Gillespie, et al. (1997). "Effects of maternal ethanol consumption and buspirone treatment on 5-HT1A and 5-HT2A receptors in offspring." Alcohol Clin Exp Res **21**(7): 1169-78.
- Kim, J. K., S. N. Summer, et al. (2001). "Role of glucocorticoid hormones in arginine vasopressin gene regulation." Biochem Biophys Res Commun **289**(5): 1252-6.
- King, B. R., R. Smith, et al. (2002). "Novel glucocorticoid and cAMP interactions on the CRH gene promoter." Mol Cell Endocrinol **194**(1-2): 19-28.
- Kocsis, K., J. Kiss, et al. (2003). "Location of putative glutamatergic neurons projecting to the medial preoptic area of the rat hypothalamus." Brain Res Bull **61**(4): 459-68.
- Laroche, J., L. Gasbarro, et al. (2009). "Reduced behavioral response to gonadal hormones in mice shipped during the peripubertal/adolescent period." Endocrinology **150**(5): 2351-8.
- Lauing, K., R. Himes, et al. (2008). "Binge alcohol treatment of adolescent rats followed by alcohol abstinence is associated with site-specific differences in bone loss and incomplete recovery of bone mass and strength." Alcohol **42**(8): 649-56.
- Laviola, G., W. Adriani, et al. (2002). "Peculiar response of adolescent mice to acute and chronic stress and to amphetamine: evidence of sex differences." Behav Brain Res **130**(1-2): 117-25.
- Le Drean, Y., N. Mincheneau, et al. (2002). "Potentiation of glucocorticoid receptor transcriptional activity by sumoylation." Endocrinology **143**(9): 3482-9.
- Lee, J. H., N. F. Tajuddin, et al. (2009). "Effects of ethanol and ipsapirone on the expression of genes encoding anti-apoptotic proteins and an antioxidant enzyme in ethanol-treated neurons." Brain Res **1249**: 54-60.
- Lee, S., I. Choi, et al. (2008). "Role of various neurotransmitters in mediating the long-term endocrine consequences of prenatal alcohol exposure." Ann N Y Acad Sci **1144**: 176-88.
- Lee, S., T. Imaki, et al. (1990). "Effect of prenatal exposure to ethanol on the activity of the hypothalamic-pituitary-adrenal axis of the offspring: Importance of the time of exposure to ethanol and possible modulating mechanisms." Mol Cell Neurosci **1**(2): 168-77.
- Lenroot, R. K. and J. N. Giedd (2006). "Brain development in children and adolescents: insights from anatomical magnetic resonance imaging." Neurosci Biobehav Rev **30**(6): 718-29.

- Li, J., M. Siegel, et al. "Estrogen enhances neurogenesis and behavioral recovery after stroke." J Cereb Blood Flow Metab **31**(2): 413-25.
- Li, Z., S. S. Kang, et al. (2005). "Effect of ethanol on the regulation of corticotropin-releasing factor (CRF) gene expression." Mol Cell Neurosci **29**(3): 345-54.
- Liposits, Z., C. Phelix, et al. (1987). "Synaptic interaction of serotonergic axons and corticotropin releasing factor (CRF) synthesizing neurons in the hypothalamic paraventricular nucleus of the rat. A light and electron microscopic immunocytochemical study." Histochemistry **86**(6): 541-9.
- Little, H. J., A. P. Croft, et al. (2008). "Selective increases in regional brain glucocorticoid: a novel effect of chronic alcohol." Neuroscience **156**(4): 1017-27.
- Liu, R. Y., U. A. Unmehopa, et al. (2006). "Glucocorticoids suppress vasopressin gene expression in human suprachiasmatic nucleus." J Steroid Biochem Mol Biol **98**(4-5): 248-53.
- Liu, Y., A. Kamitakahara, et al. (2008). "Cyclic adenosine 3',5'-monophosphate responsive element binding protein phosphorylation is required but not sufficient for activation of corticotropin-releasing hormone transcription." Endocrinology **149**(7): 3512-20.
- Lolait, S. J., A. M. O'Carroll, et al. (1995). "Extrapituitary expression of the rat V1b vasopressin receptor gene." Proc Natl Acad Sci U S A **92**(15): 6783-7.
- Luders, E., P. M. Thompson, et al. "The development of the corpus callosum in the healthy human brain." J Neurosci **30**(33): 10985-90.
- Luders, E., P. M. Thompson, et al. (2010). "The development of the corpus callosum in the healthy human brain." J Neurosci **30**(33): 10985-90.
- Lund, T. D., L. R. Hinds, et al. (2006). "The androgen 5alpha-dihydrotestosterone and its metabolite 5alpha-androstan-3beta, 17beta-diol inhibit the hypothalamo-pituitary-adrenal response to stress by acting through estrogen receptor beta-expressing neurons in the hypothalamus." J Neurosci **26**(5): 1448-56.
- Lund, T. D., T. Rovis, et al. (2005). "Novel actions of estrogen receptor-beta on anxiety-related behaviors." Endocrinology **146**(2): 797-807.
- Madeira, M. D., J. P. Andrade, et al. (1997). "Chronic alcohol consumption and withdrawal do not induce cell death in the suprachiasmatic nucleus, but lead to irreversible depression of peptide immunoreactivity and mRNA levels." J Neurosci **17**(4): 1302-19.

- Makhija, N. J. and L. Sher (2007). "Preventing suicide in adolescents with alcohol use disorders." Int J Adolesc Med Health **19**(1): 53-9.
- Makino, S., J. Schulkin, et al. (1995). "Regulation of corticotropin-releasing hormone receptor messenger ribonucleic acid in the rat brain and pituitary by glucocorticoids and stress." Endocrinology **136**(10): 4517-25.
- Makino, S., M. A. Smith, et al. (1995). "Increased expression of corticotropin-releasing hormone and vasopressin messenger ribonucleic acid (mRNA) in the hypothalamic paraventricular nucleus during repeated stress: association with reduction in glucocorticoid receptor mRNA levels." Endocrinology **136**(8): 3299-309.
- Maldonado-Devincci, A. M., K. A. Badanich, et al. "Alcohol during adolescence selectively alters immediate and long-term behavior and neurochemistry." Alcohol **44**(1): 57-66.
- Malkoski, S. P. and R. I. Dorin (1999). "Composite glucocorticoid regulation at a functionally defined negative glucocorticoid response element of the human corticotropin-releasing hormone gene." Mol Endocrinol **13**(10): 1629-44.
- Mauras, N., A. D. Rogol, et al. (1996). "Sex steroids, growth hormone, insulin-like growth factor-1: neuroendocrine and metabolic regulation in puberty." Horm Res **45**(1-2): 74-80.
- McAlhany, R. E., Jr., R. C. Miranda, et al. (1999). "Ethanol decreases Glial-Derived Neurotrophic Factor (GDNF) protein release but not mRNA expression and increases GDNF-stimulated Shc phosphorylation in the developing cerebellum." Alcohol Clin Exp Res **23**(10): 1691-7.
- McCarthy, M. M., C. H. McDonald, et al. (1996). "An anxiolytic action of oxytocin is enhanced by estrogen in the mouse." Physiol Behav **60**(5): 1209-15.
- McCormick, C. M. and I. Z. Mathews (2007). "HPA function in adolescence: role of sex hormones in its regulation and the enduring consequences of exposure to stressors." Pharmacol Biochem Behav **86**(2): 220-33.
- McCullough, L. D., K. Blizzard, et al. (2003). "Aromatase cytochrome P450 and extragonadal estrogen play a role in ischemic neuroprotection." J Neurosci **23**(25): 8701-5.
- McEvoy, P. M. and F. Shand (2008). "The effect of comorbid substance use disorders on treatment outcome for anxiety disorders." J Anxiety Disord **22**(6): 1087-98.

- Meurisse, M., E. Chaillou, et al. (2009). "Afferent and efferent connections of the cortical and medial nuclei of the amygdala in sheep." J Chem Neuroanat **37**(2): 87-97.
- Miki, T., S. J. Harris, et al. (2003). "Effects of alcohol exposure during early life on neuron numbers in the rat hippocampus. I. Hilus neurons and granule cells." Hippocampus **13**(3): 388-98.
- Mikkelsen, J. D., A. Hay-Schmidt, et al. (2004). "Serotonergic stimulation of the rat hypothalamo-pituitary-adrenal axis: interaction between 5-HT1A and 5-HT2A receptors." Ann N Y Acad Sci **1018**: 65-70.
- Miller, M. A., L. Vician, et al. (1989). "Sex differences in vasopressin neurons in the bed nucleus of the stria terminalis by in situ hybridization." Peptides **10**(3): 615-9.
- Miller, W. J., S. Suzuki, et al. (2004). "Estrogen receptor (ER)beta isoforms rather than ERalpha regulate corticotropin-releasing hormone promoter activity through an alternate pathway." J Neurosci **24**(47): 10628-35.
- Morsink, M. C., P. J. Steenbergen, et al. (2006). "Acute activation of hippocampal glucocorticoid receptors results in different waves of gene expression throughout time." J Neuroendocrinol **18**(4): 239-52.
- Newport, D. J., C. Heim, et al. (2003). "Cerebrospinal fluid corticotropin-releasing factor (CRF) and vasopressin concentrations predict pituitary response in the CRF stimulation test: a multiple regression analysis." Neuropsychopharmacology **28**(3): 569-76.
- Nishikawa, T. and C. A. Strott (1984). "Cortisol production by cells isolated from the outer and inner zones of the adrenal cortex of the guinea pig." Endocrinology **114**(2): 486-91.
- Ogilvie, K., S. Lee, et al. (1997). "Effect of three different modes of alcohol administration on the activity of the rat hypothalamic-pituitary-adrenal axis." Alcohol Clin Exp Res **21**(3): 467-76.
- Ogilvie, K., S. Lee, et al. (1998). "Mechanisms mediating the influence of alcohol on the hypothalamic-pituitary-adrenal axis responses to immune and nonimmune signals." Alcohol Clin Exp Res **22**(5 Suppl): 243S-247S.
- Ogilvie, K. M., S. Lee, et al. (1997). "Role of arginine vasopressin and corticotropin-releasing factor in mediating alcohol-induced adrenocorticotropin and vasopressin secretion in male rats bearing lesions of the paraventricular nuclei." Brain Res **744**(1): 83-95.
- Ogilvie, K. M., S. Lee, et al. (1998). "Divergence in the expression of molecular markers of neuronal activation in the parvocellular paraventricular nucleus

of the hypothalamus evoked by alcohol administration via different routes." J Neurosci **18**(11): 4344-52.

- Ogilvie, K. M. and C. Rivier (1996). "Gender difference in alcohol-evoked hypothalamic-pituitary-adrenal activity in the rat: ontogeny and role of neonatal steroids." Alcohol Clin Exp Res **20**(2): 255-61.
- Ogilvie, K. M. and C. Rivier (1997). "Gender difference in hypothalamic-pituitary-adrenal axis response to alcohol in the rat: activational role of gonadal steroids." Brain Res **766**(1-2): 19-28.
- Ogilvie, K. M. and C. Rivier (1997). "Prenatal alcohol exposure results in hyperactivity of the hypothalamic-pituitary-adrenal axis of the offspring: modulation by fostering at birth and postnatal handling." Alcohol Clin Exp Res **21**(3): 424-9.
- Ostrander, M. M., Y. M. Ulrich-Lai, et al. (2009). "Chronic stress produces enduring decreases in novel stress-evoked c-fos mRNA expression in discrete brain regions of the rat." Stress **12**(6): 469-77.
- Ostrander, M. M., Y. M. Ulrich-Lai, et al. (2006). "Hypoactivity of the hypothalamo-pituitary-adrenocortical axis during recovery from chronic variable stress." Endocrinology **147**(4): 2008-17.
- Ostrowski, N. L., S. J. Lolait, et al. (1992). "Distribution of V1a and V2 vasopressin receptor messenger ribonucleic acids in rat liver, kidney, pituitary and brain." Endocrinology **131**(1): 533-5.
- Pak, T. R., W. C. Chung, et al. (2007). "Estrogen receptor-beta mediates dihydrotestosterone-induced stimulation of the arginine vasopressin promoter in neuronal cells." Endocrinology **148**(7): 3371-82.
- Pak, T. R., W. C. Chung, et al. (2009). "Arginine vasopressin regulation in pre- and postpubertal male rats by the androgen metabolite 3beta-diol." Am J Physiol Endocrinol Metab **296**(6): E1409-13.
- Pandey, S. C., R. Ugale, et al. (2008). "Brain chromatin remodeling: a novel mechanism of alcoholism." J Neurosci **28**(14): 3729-37.
- Papadimitriou, A. and K. N. Priftis (2009). "Regulation of the hypothalamic-pituitary-adrenal axis." Neuroimmunomodulation **16**(5): 265-71.
- Pascual, M., A. M. Blanco, et al. (2007). "Intermittent ethanol exposure induces inflammatory brain damage and causes long-term behavioural alterations in adolescent rats." Eur J Neurosci **25**(2): 541-50.
- Pascual, M., J. Boix, et al. (2009). "Repeated alcohol administration during adolescence causes changes in the mesolimbic dopaminergic and

glutamatergic systems and promotes alcohol intake in the adult rat." J Neurochem **108**(4): 920-31.

Patchev, V. K. and O. F. Almeida (1996). "Gonadal steroids exert facilitating and "buffering" effects on glucocorticoid-mediated transcriptional regulation of corticotropin-releasing hormone and corticosteroid receptor genes in rat brain." J Neurosci **16**(21): 7077-84.

Patchev, V. K., S. Hayashi, et al. (1999). "Ontogeny of gender-specific responsiveness to stress and glucocorticoids in the rat and its determination by the neonatal gonadal steroid environment." Stress **3**(1): 41-54.

Paus, T., A. Zijdenbos, et al. (1999). "Structural maturation of neural pathways in children and adolescents: in vivo study." Science **283**(5409): 1908-11.

Pervanidou, P. and G. P. Chrousos "Neuroendocrinology of post-traumatic stress disorder." Prog Brain Res **182**: 149-60.

Pickering, C., G. Wicher, et al. "A low ethanol dose affects all types of cells in mixed long-term embryonic cultures of the cerebellum." Basic Clin Pharmacol Toxicol **106**(6): 472-8.

Pietranera, L., M. J. Bellini, et al. "Increased aromatase expression in the hippocampus of spontaneously hypertensive rats: effects of estradiol administration." Neuroscience **174**: 151-9.

Pompili, M., G. Serafini, et al. "Suicidal behavior and alcohol abuse." Int J Environ Res Public Health **7**(4): 1392-431.

Popovic, M., M. Caballero-Bleda, et al. (2004). "Multiple binge alcohol consumption during rat adolescence increases anxiety but does not impair retention in the passive avoidance task." Neurosci Lett **357**(2): 79-82.

Pradidarcheep, W. and U. Showpittapornchai (2009). "From prenatal life into senescence, testosterone is essential requirement for manhood." J Med Assoc Thai **92**(4): 573-87.

Przybycien-Szymanska, M. M., Y. S. Rao, et al. (2009). "Binge-pattern alcohol exposure during puberty induces sexually dimorphic changes in genes regulating the HPA axis." Am J Physiol Endocrinol Metab.

Przybycien-Szymanska, M. M., Y. S. Rao, et al. (2010). "Binge-pattern alcohol exposure during puberty induces sexually dimorphic changes in genes regulating the HPA axis." Am J Physiol Endocrinol Metab **298**(2): E320-8.

- Quadros, P. S., J. L. Pfau, et al. (2002). "Sex differences in progesterone receptor expression: a potential mechanism for estradiol-mediated sexual differentiation." Endocrinology **143**(10): 3727-39.
- Rainey, W. E., B. R. Carr, et al. (2002). "Dissecting human adrenal androgen production." Trends Endocrinol Metab **13**(6): 234-9.
- Rajpert, E. J., F. P. Lemaigre, et al. (1987). "Glucocorticoid receptors bound to the antagonist RU486 are not downregulated despite their capacity to interact in vitro with defined gene regions." J Steroid Biochem **26**(5): 513-20.
- Ramachandran, V., L. T. Watts, et al. (2003). "Ethanol-induced oxidative stress precedes mitochondrially mediated apoptotic death of cultured fetal cortical neurons." J Neurosci Res **74**(4): 577-88.
- Rankin, S. L., G. D. Partlow, et al. (2003). "Postnatal neurogenesis in the vasopressin and oxytocin-containing nucleus of the pig hypothalamus." Brain Res **971**(2): 189-96.
- Raymond, A. D., N. N. Kucherepa, et al. (2006). "Neurogenesis of oxytocin-containing neurons in the paraventricular nucleus (PVN) of the female pig in 3 reproductive states: puberty gilts, adult gilts and lactating sows." Brain Res **1102**(1): 44-51.
- Ring, R. H., J. E. Malberg, et al. (2006). "Anxiolytic-like activity of oxytocin in male mice: behavioral and autonomic evidence, therapeutic implications." Psychopharmacology (Berl) **185**(2): 218-25.
- Rivier, C. (1993). "Female rats release more corticosterone than males in response to alcohol: influence of circulating sex steroids and possible consequences for blood alcohol levels." Alcohol Clin Exp Res **17**(4): 854-9.
- Rivier, C., T. Bruhn, et al. (1984). "Effect of ethanol on the hypothalamic-pituitary-adrenal axis in the rat: role of corticotropin-releasing factor (CRF)." J Pharmacol Exp Ther **229**(1): 127-31.
- Rivier, C. and S. Lee (1996). "Acute alcohol administration stimulates the activity of hypothalamic neurons that express corticotropin-releasing factor and vasopressin." Brain Res **726**(1-2): 1-10.
- Rivier, C., J. Rivier, et al. (1996). "Importance of pituitary and brain receptors for corticotrophin-releasing factor in modulating alcohol-induced ACTH secretion in the rat." Brain Res **721**(1-2): 83-90.
- Rivier, C., J. Rivier, et al. (1984). "Studies of the nature of the interaction between vasopressin and corticotropin-releasing factor on adrenocorticotropin release in the rat." Endocrinology **115**(3): 882-6.

- Rivier, C. L., D. E. Grigoriadis, et al. (2003). "Role of corticotropin-releasing factor receptors type 1 and 2 in modulating the rat adrenocorticotropin response to stressors." Endocrinology **144**(6): 2396-403.
- Rivier, J., C. Rivier, et al. (1984). "Synthetic competitive antagonists of corticotropin-releasing factor: effect on ACTH secretion in the rat." Science **224**(4651): 889-91.
- Robertson, G. L. (2001). "Antidiuretic hormone. Normal and disordered function." Endocrinol Metab Clin North Am **30**(3): 671-94, vii.
- Rodaros, D., D. A. Caruana, et al. (2007). "Corticotropin-releasing factor projections from limbic forebrain and paraventricular nucleus of the hypothalamus to the region of the ventral tegmental area." Neuroscience **150**(1): 8-13.
- Romeo, R. D. (2003). "Puberty: a period of both organizational and activational effects of steroid hormones on neurobehavioural development." J Neuroendocrinol **15**(12): 1185-92.
- Romeo, R. D., R. Bellani, et al. (2006). "Stress history and pubertal development interact to shape hypothalamic-pituitary-adrenal axis plasticity." Endocrinology **147**(4): 1664-74.
- Romeo, R. D., S. J. Lee, et al. (2004). "Testosterone cannot activate an adult-like stress response in prepubertal male rats." Neuroendocrinology **79**(3): 125-32.
- Romeo, R. D. and B. S. McEwen (2006). "Stress and the adolescent brain." Ann N Y Acad Sci **1094**: 202-14.
- Rosol, T. J., J. T. Yarrington, et al. (2001). "Adrenal gland: structure, function, and mechanisms of toxicity." Toxicol Pathol **29**(1): 41-8.
- Roy, A., N. Mittal, et al. (2002). "Modulation of cellular expression of glucocorticoid receptor and glucocorticoid response element-DNA binding in rat brain during alcohol drinking and withdrawal." J Pharmacol Exp Ther **301**(2): 774-84.
- Sage, D., D. Maurel, et al. (2002). "Corticosterone-dependent driving influence of the suprachiasmatic nucleus on adrenal sensitivity to ACTH." Am J Physiol Endocrinol Metab **282**(2): E458-65.
- Saleh, T. M., B. J. Connell, et al. (2005). "Estrogen synthesis in the central nucleus of the amygdala following middle cerebral artery occlusion: role in modulating neurotransmission." Neuroscience **135**(4): 1141-53.

- Sapolsky, R. M., L. M. Romero, et al. (2000). "How do glucocorticoids influence stress responses? Integrating permissive, suppressive, stimulatory, and preparative actions." Endocr Rev **21**(1): 55-89.
- Sawchenko, P. E. and M. C. Bohn (1989). "Glucocorticoid receptor-immunoreactivity in C1, C2, and C3 adrenergic neurons that project to the hypothalamus or to the spinal cord in the rat." J Comp Neurol **285**(1): 107-16.
- Sawchenko, P. E. and L. W. Swanson (1982). "The organization of noradrenergic pathways from the brainstem to the paraventricular and supraoptic nuclei in the rat." Brain Res **257**(3): 275-325.
- Schoenau, E. (2006). "Bone mass increase in puberty: what makes it happen?" Horm Res **65 Suppl 2**: 2-10.
- Schulkin, J., P. W. Gold, et al. (1998). "Induction of corticotropin-releasing hormone gene expression by glucocorticoids: implication for understanding the states of fear and anxiety and allostatic load." Psychoneuroendocrinology **23**(3): 219-43.
- Schulz, M., M. Eggert, et al. (2002). "RU486-induced glucocorticoid receptor agonism is controlled by the receptor N terminus and by corepressor binding." J Biol Chem **277**(29): 26238-43.
- Scordalakes, E. M. and E. F. Rissman (2004). "Aggression and arginine vasopressin immunoreactivity regulation by androgen receptor and estrogen receptor alpha." Genes Brain Behav **3**(1): 20-6.
- Scott, L. V. and T. G. Dinan (1998). "Vasopressin and the regulation of hypothalamic-pituitary-adrenal axis function: implications for the pathophysiology of depression." Life Sci **62**(22): 1985-98.
- Sencar-Cupovic, I. and S. Milkovic (1976). "The development of sex differences in the adrenal morphology and responsiveness in stress of rats from birth to the end of life." Mech Ageing Dev **5**(1): 1-9.
- Sierra, A., I. Azcoitia, et al. (2003). "Endogenous estrogen formation is neuroprotective in model of cerebellar ataxia." Endocrine **21**(1): 43-51.
- Silva, S. M., M. D. Madeira, et al. (2002). "Prolonged alcohol intake leads to irreversible loss of vasopressin and oxytocin neurons in the paraventricular nucleus of the hypothalamus." Brain Res **925**(1): 76-88.
- Silva, S. M., M. M. Paula-Barbosa, et al. (2002). "Prolonged alcohol intake leads to reversible depression of corticotropin-releasing hormone and vasopressin immunoreactivity and mRNA levels in the parvocellular neurons of the paraventricular nucleus." Brain Res **954**(1): 82-93.

- Sisk, C. L., H. N. Richardson, et al. (2001). "In vivo gonadotropin-releasing hormone secretion in female rats during peripubertal development and on proestrus." Endocrinology **142**(7): 2929-36.
- Sisk, C. L. and J. L. Zehr (2005). "Pubertal hormones organize the adolescent brain and behavior." Front Neuroendocrinol **26**(3-4): 163-74.
- Sladek, C. D., K. L. Swenson, et al. (2000). "The role of steroid hormones in the regulation of vasopressin and oxytocin release and mRNA expression in hypothalamo-neurohypophysial explants from the rat." Exp Physiol **85 Spec No**: 171S-177S.
- Slawecki, C. J., A. Thorsell, et al. (2004). "Long-term neurobehavioral effects of alcohol or nicotine exposure in adolescent animal models." Ann N Y Acad Sci **1021**: 448-52.
- Smith, K. L., J. V. Gardiner, et al. (2008). "Overexpression of CART in the PVN increases food intake and weight gain in rats." Obesity (Silver Spring) **16**(10): 2239-44.
- Smith, M. A., J. Davidson, et al. (1989). "The corticotropin-releasing hormone test in patients with posttraumatic stress disorder." Biol Psychiatry **26**(4): 349-55.
- Soliman, A. T., M. M. Khadir, et al. (1995). "Testosterone treatment in adolescent boys with constitutional delay of growth and development." Metabolism **44**(8): 1013-5.
- Spencer, R. L. and B. S. McEwen (1990). "Adaptation of the hypothalamic-pituitary-adrenal axis to chronic ethanol stress." Neuroendocrinology **52**(5): 481-9.
- Steimer, T., A. Python, et al. (2007). "Plasma corticosterone, dexamethasone (DEX) suppression and DEX/CRH tests in a rat model of genetic vulnerability to depression." Psychoneuroendocrinology **32**(5): 575-9.
- Stroud, L. R., G. D. Papandonatos, et al. (2004). "Sex differences in the effects of pubertal development on responses to a corticotropin-releasing hormone challenge: the Pittsburgh psychobiologic studies." Ann N Y Acad Sci **1021**: 348-51.
- Suzuki, S. and R. J. Handa (2005). "Estrogen receptor-beta, but not estrogen receptor-alpha, is expressed in prolactin neurons of the female rat paraventricular and supraoptic nuclei: comparison with other neuropeptides." J Comp Neurol **484**(1): 28-42.
- Tabakoff, B., R. C. Jafee, et al. (1978). "Corticosterone concentrations in mice during ethanol drinking and withdrawal." J Pharm Pharmacol **30**(6): 371-4.

- Tajuddin, N. F. and M. J. Druse (1993). "Treatment of pregnant alcohol-consuming rats with buspirone: effects on serotonin and 5-hydroxyindoleacetic acid content in offspring." Alcohol Clin Exp Res **17**(1): 110-4.
- Tajuddin, N. F. and M. J. Druse (1999). "In utero ethanol exposure decreased the density of serotonin neurons. Maternal ipsapirone treatment exerted a protective effect." Brain Res Dev Brain Res **117**(1): 91-7.
- Taylor, A. N., B. J. Branch, et al. (1981). "Neuroendocrine effects of fetal alcohol exposure." Prog Biochem Pharmacol **18**: 99-110.
- Taylor, A. N., L. R. Nelson, et al. (1984). "Altered stress responsiveness in adult rats exposed to ethanol in utero: neuroendocrine mechanisms." Ciba Found Symp **105**: 47-65.
- Tomas, F. M., H. N. Munro, et al. (1979). "Effect of glucocorticoid administration on the rate of muscle protein breakdown in vivo in rats, as measured by urinary excretion of N tau-methylhistidine." Biochem J **178**(1): 139-46.
- van der Laan, S., E. R. de Kloet, et al. (2009). "Timing is critical for effective glucocorticoid receptor mediated repression of the cAMP-induced CRH gene." PLoS One **4**(1): e4327.
- Van, L. P., D. H. Spengler, et al. (1990). "Glucocorticoid repression of 3',5'-cyclic-adenosine monophosphate-dependent human corticotropin-releasing-hormone gene promoter activity in a transfected mouse anterior pituitary cell line." Endocrinology **127**(3): 1412-8.
- Vazquez, D. M. and H. Akil (1993). "Pituitary-adrenal response to ether vapor in the weanling animal: characterization of the inhibitory effect of glucocorticoids on adrenocorticotropin secretion." Pediatr Res **34**(5): 646-53.
- Veiga, S., I. Azcoitia, et al. (2005). "Extragonadal synthesis of estradiol is protective against kainic acid excitotoxic damage to the hippocampus." Neuroreport **16**(14): 1599-603.
- Venken, K., S. Moverare-Skrtic, et al. (2007). "Impact of androgens, growth hormone, and IGF-I on bone and muscle in male mice during puberty." J Bone Miner Res **22**(1): 72-82.
- Viau, V., B. Bingham, et al. (2005). "Gender and puberty interact on the stress-induced activation of parvocellular neurosecretory neurons and corticotropin-releasing hormone messenger ribonucleic acid expression in the rat." Endocrinology **146**(1): 137-46.

- Viau, V., A. Chu, et al. (1999). "Independent and overlapping effects of corticosterone and testosterone on corticotropin-releasing hormone and arginine vasopressin mRNA expression in the paraventricular nucleus of the hypothalamus and stress-induced adrenocorticotrophic hormone release." J Neurosci **19**(15): 6684-93.
- Viau, V., P. Lee, et al. (2003). "A testicular influence on restraint-induced activation of medial parvocellular neurons in the paraventricular nucleus in the male rat." Endocrinology **144**(7): 3067-75.
- Viau, V. and M. J. Meaney (1996). "The inhibitory effect of testosterone on hypothalamic-pituitary-adrenal responses to stress is mediated by the medial preoptic area." J Neurosci **16**(5): 1866-76.
- Walker, B. M. and C. L. Ehlers (2009). "Age-related differences in the blood alcohol levels of Wistar rats." Pharmacol Biochem Behav **91**(4): 560-5.
- Weinberg, J. (1988). "Hyperresponsiveness to stress: differential effects of prenatal ethanol on males and females." Alcohol Clin Exp Res **12**(5): 647-52.
- Weiser, M. J. and R. J. Handa (2009). "Estrogen impairs glucocorticoid dependent negative feedback on the hypothalamic-pituitary-adrenal axis via estrogen receptor alpha within the hypothalamus." Neuroscience **159**(2): 883-95.
- White, A. M., C. L. Kraus, et al. (2006). "Many college freshmen drink at levels far beyond the binge threshold." Alcohol Clin Exp Res **30**(6): 1006-10.
- Wigger, A., M. M. Sanchez, et al. (2004). "Alterations in central neuropeptide expression, release, and receptor binding in rats bred for high anxiety: critical role of vasopressin." Neuropsychopharmacology **29**(1): 1-14.
- Williamson, M. and V. Viau (2008). "Selective contributions of the medial preoptic nucleus to testosterone-dependant regulation of the paraventricular nucleus of the hypothalamus and the HPA axis." Am J Physiol Regul Integr Comp Physiol **295**(4): R1020-30.
- Woo, T. U., M. L. Pucak, et al. (1997). "Peripubertal refinement of the intrinsic and associational circuitry in monkey prefrontal cortex." Neuroscience **80**(4): 1149-58.
- Wood, S. K., H. E. Walker, et al. "Individual differences in reactivity to social stress predict susceptibility and resilience to a depressive phenotype: role of corticotropin-releasing factor." Endocrinology **151**(4): 1795-805.
- Wotjak, C. T., M. Kubota, et al. (1996). "Release of vasopressin within the rat paraventricular nucleus in response to emotional stress: a novel

mechanism of regulating adrenocorticotrophic hormone secretion?" J Neurosci **16**(23): 7725-32.

- Woulfe, J. M., A. W. Hryciyshyn, et al. (1988). "Collateral axonal projections from the A1 noradrenergic cell group to the paraventricular nucleus and bed nucleus of the stria terminalis in the rat." Exp Neurol **102**(1): 121-4.
- Yamamori, E., Y. Iwasaki, et al. (2007). "Molecular mechanisms for corticotropin-releasing hormone gene repression by glucocorticoid in BE(2)C neuronal cell line." Mol Cell Endocrinol **264**(1-2): 142-8.
- Yamamoto, S., S. Morinobu, et al. (2009). "Single prolonged stress: toward an animal model of posttraumatic stress disorder." Depress Anxiety **26**(12): 1110-7.
- Yoshida, M., Y. Iwasaki, et al. (2006). "Identification of a functional AP1 element in the rat vasopressin gene promoter." Endocrinology **147**(6): 2850-63.
- Young, L. S., G. Murphy, et al. (2003). "Differential production of adrenal steroids by purified cells of the human adrenal cortex is relative rather than absolute." Eur J Endocrinol **148**(1): 139-45.
- Yue, C., N. Mutsuga, et al. (2006). "Studies of oxytocin and vasopressin gene expression in the rat hypothalamus using exon- and intron-specific probes." Am J Physiol Regul Integr Comp Physiol **290**(5): R1233-41.
- Zehr, J. L., B. J. Todd, et al. (2006). "Dendritic pruning of the medial amygdala during pubertal development of the male Syrian hamster." J Neurobiol **66**(6): 578-90.
- Zhang, Y., D. K. Raap, et al. (2000). "Long-term fluoxetine produces behavioral anxiolytic effects without inhibiting neuroendocrine responses to conditioned stress in rats." Brain Res **855**(1): 58-66.
- Zilberman, M. L., H. Tavares, et al. (2003). "Substance use disorders: sex differences and psychiatric comorbidities." Can J Psychiatry **48**(1): 5-13.

VITA

The author, Magdalena Malgorzata Przybycien-Szymanska was born on May 25, 1982 in Gorlice, Poland to Marta and Marek Przybycien. After finishing the third year of her education in Marcin Kromer High School in 2000, she and her family came to the United States, where she graduated from Lake Park High School, Roselle, Illinois in 2001. After receiving her secondary education, Magdalena attended W.R. Harper Community College, Palatine, Illinois for two years after which she transferred to Loyola University Chicago, where she received her Bachelor of Science degree in Biology in 2005.

During biology class in 7th grade, Magdalena learned that she loved human anatomy and physiology and she wanted to learn more about how the human body works. At that time, she took part in a “Biology Olympics” district event in which she took a second place. She then continued her studies in biology through high school and geared her college classes toward pre-medical training while considering a career of a pediatric endocrinologist.

After graduating college in 2005, Magdalena entered the master’s program in the Department of Cell Biology, Neurobiology and Anatomy at the Loyola University Medical Center Graduate School. Her fascination with endocrinology led her to the laboratory of Dr. Lydia L. DonCarlos. In the winter of 2005, she entered Dr. DonCarlos’ laboratory where she focused her passion in

life toward neuroendocrine research. Magdalena received a Master of Science degree in Cell Biology, Neurobiology and Anatomy in 2007.

After graduating with a MS degree, in the fall of 2007 she entered Neuroscience Graduate Program at the Loyola University Medical Center Graduate School. Her interests in endocrinology and pubertal development led her to the laboratory of Dr. Toni R. Pak. She joined Dr. Pak's laboratory in the spring of 2008. Here she worked on the neuroendocrine consequences of binge alcohol exposure during puberty on the functioning of the pubertal and adult hypothalamo-pituitary-adrenal axis, the physiological system responsible for maintaining homeostasis after stress. During the course of her graduate education, Magdalena presented her work at multiple national and international conferences and was a recipient of multiple awards, including a Research Society on Alcoholisms Student Merit Award, travel stipend awarded by the Federation of European Neuroscience Societies for the 9th International Congress of the Polish Neuroscience Society held in Warsaw, Poland, and an Endocrine Trainee Day Travel Award. She is an author of multiple abstracts, including an abstract presented at the press conference held during 2010 annual meeting of the Society for Neuroscience entitled "Teen Vulnerability. Drug Exposure during Adolescence Has Long-Lasting Consequences".

Magdalena married her husband Marcin Szymanski in 2008. They currently reside in Schaumburg, Illinois. After completing her PhD, Magdalena is planning to pursue her neuroendocrine research interests as a post-doctoral fellow. In her future career she would like to investigate how the developing reproductive

system influences maturation of the hypothalamo-pituitary-adrenal axis during adolescence.

DISSERTATION APPROVAL SHEET

The dissertation submitted by Magdalena M. Przybycien-Szymanska has been read and approved by the following committee:

Toni R. Pak, Ph.D., Director
Assistant Professor of Cell and Molecular Physiology Department
Loyola University Chicago

John J. Callaci, Ph.D.
Assistant Professor of Orthopedic Surgery and Rehabilitation Department
Loyola University Chicago

George Battaglia, Ph.D,
Professor of Pharmacology Department
Loyola University Chicago

Lydia L. DonCarlos, Ph.D,
Professor of Cell and Molecular Physiology Department
Loyola University Chicago

Mary J. Druse-Manteuffel, Ph.D,
Professor of Cell and Molecular Physiology Department
Loyola University Chicago

The final copies have been examined by the director of the dissertation and the signature which appears below verifies the fact that any necessary changes have been incorporated and that the dissertation is now given final approval by the committee with reference to content and form.

The dissertation is therefore accepted in partial fulfillment of the requirements for the degree of Doctor of Philosophy.

Date

Director's Signature

