



1972

An Analysis of the Facilitatory Action of Catechol and Phenol at the Neuromuscular Junction of the Cat

Joel P. Gallagher
Loyola University Chicago

Recommended Citation

Gallagher, Joel P., "An Analysis of the Facilitatory Action of Catechol and Phenol at the Neuromuscular Junction of the Cat" (1972).
Dissertations. Paper 1138.
http://ecommons.luc.edu/luc_diss/1138

This Dissertation is brought to you for free and open access by the Theses and Dissertations at Loyola eCommons. It has been accepted for inclusion in Dissertations by an authorized administrator of Loyola eCommons. For more information, please contact ecommons@luc.edu.



This work is licensed under a [Creative Commons Attribution-Noncommercial-No Derivative Works 3.0 License](https://creativecommons.org/licenses/by-nc-nd/3.0/).
Copyright © 1972 Joel P. Gallagher

AN ANALYSIS OF THE FACILITATORY ACTION
OF CATECHOL AND PHENOL
AT THE NEUROMUSCULAR JUNCTION OF THE CAT

A dissertation presented by

Joel P. Gallagher

for the degree

of

DOCTOR OF PHILOSOPHY

at the

DEPARTMENT OF PHARMACOLOGY

LOYOLA UNIVERSITY MEDICAL CENTER

MAYWOOD, ILLINOIS

February, 1972

LIBRARY
LOYOLA UNIVERSITY MEDICAL CENTER

BIOGRAPHY

Joel P. Gallagher was born on December 12, 1942, in Chicago, Illinois. In June of 1960 he graduated from Fenwick High School, Oak Park. The following Fall he began his undergraduate training at the College of St. Thomas, St. Paul, Minnesota where he received the Bachelor of Science degree in Biology-Chemistry in June 1964. At this time he entered the University of Illinois College of Pharmacy where in June of 1967, he received a Bachelor of Science degree in Pharmacy.

After completing his apprenticeship in 1967 and passing the State of Illinois License Examination to Practice Pharmacy, he has served as a registered community pharmacist.

In September of 1967, Mr. Gallagher was accepted as a graduate student in the Department of Pharmacology at Loyola University Medical Center. At this time he was granted a National Science Foundation Traineeship which was renewed annually till September, 1971. He was a student of Dr. L. C. Blaber until June, 1970, at which time Dr. A. G. Karczmar became his principal advisor. In July, 1971, Mr. Gallagher was selected as a participant in the Third Supplementary Training Program for graduate students sponsored by the American Society for Pharmacology and Experimental Therapeutics.

ACKNOWLEDGEMENTS

I wish to express my deepest appreciation to Dr. L. C. Blaber for his training and advice during his tenure at Loyola University Medical Center. I am also very grateful for the guidance extended to me by Dr. A. G. Karczmar throughout my course of training at Loyola especially in the preparation of this dissertation. I also wish to thank Dr. R. S. Jacobs for his continuous assistance.

I would like to express sincerest gratitude to my mother and father for their constant support and encouragement.

TABLE OF CONTENTS

Introduction

Anatomy	1
Physiology	10
Pharmacology	27

Methods	58
-------------------	----

Results	79
-------------------	----

Discussion	126
----------------------	-----

Conclusion	144
----------------------	-----

Bibliography	147
------------------------	-----

ABBREVIATIONS

Å	angstrom
ACh	acetylcholine
AChE	acetylcholinesterase
°C	degrees centigrade
c. a.	close-arterial route of administration
Ca	calcium
[Ca ⁺⁺]	calcium ion concentration
C-AMP	cyclic-3', 5'-adenosine monophosphate
ChE	cholinesterase
cm	centimeter
CO ₂	carbon dioxide
C. V.	coefficient of variation
dm	mobilization rate
d-Tc	d-tubocurarine
epp	endplate potential
E _K	potassium equilibrium potential
E _{Na}	sodium equilibrium potential
head	the first fifteen epps of a tetanus
i. v.	intravenous route of administration
K	potassium
kg	kilogram
k	kilohm
M ₀	quantal content of the first epp of a tetanus
mepp	miniature endplate potential
mg	milligram
[Mg ⁺⁺]	magnesium ion concentration
min	minute
ml	milliliter
mm	millimeter
msec	millisecond
mV	millivolt
M	megaohm
N	number of samples in a population
n	readily releasable store
[Na _i]	sodium ion concentration inside a cell
[Na _o]	sodium ion concentration outside a cell
O ₂	oxygen
p	probability
pH	negative log of hydrogen ion concentration
q	quantal size
S. D.	standard deviation
sec	second
tail	the epps of a tetanus excluding the head

μ_2	micron
μ^2	square micron
μF	microfarad
μg	microgram
μsec	microsecond
	ohm

ANATOMY

In the cat, the tibialis anterior (cranialis) muscle is classified as a "fast" muscle made up of predominantly white fibers (Denny-Brown, 1929). The twitch speed of the tenuissimus muscle was compared to that of the tibialis and found to be slightly slower. With regard to speed of contraction, Denny-Brown believed that the red pigmentation which is merely due to the muscle content of hemoglobin or myoglobin is not essential to its typically slower type of contraction. More recently Csilik (1967) compared red and white muscle as to cholinesterase activity and pointed out some subtle differences between these muscle types. The tibialis muscle reaches its peak contraction in about 20 msec with an overall duration of 80 msec while the corresponding values for the tenuissimus were 30 and 100 msec, respectively (Maclagen, 1962). Both muscles had about the same fusion frequency and a marked potentiation of the maximal contractions occurred post-tetanicly in both cases, irrespective of the duration of the tetanus or the frequency of stimulation.

The tibialis muscle in the cat (Fig. 1) and in man can be located in the lower limb by its insertion at the first metatarsal of the foot and also by its origin at the proximal parts of the tibia and fibula. It is a superficial muscle covering the lateral side of the cranial part of the tibia and ending as a strong tendon which passes beneath the transverse crural ligament (Crouch, 1969). A cross-section of the muscle shows that it consists of about 16,000 fibers (Porter and Hart, 1923). It is innervated by the

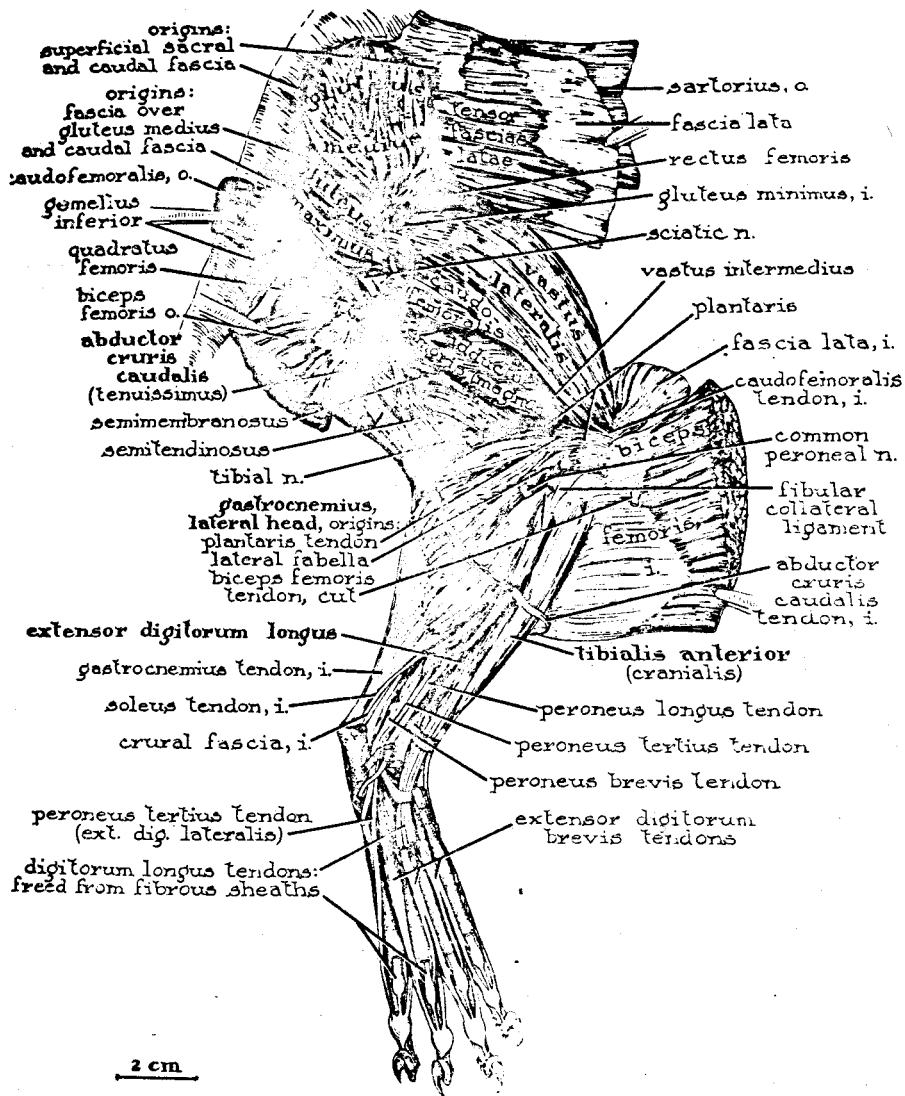

Figure 1. Superficial muscles of the right hind limb. Lateral view. (With permission of the author and publisher, Text-Atlas of Cat Anatomy, Plate 40)

peroneal nerve which arises from the sciatic. Further information regarding the branching of this nerve within the muscle is not available. This may be due to the larger size of the muscle in comparison to the tenuissimus making more discrete anatomical observation difficult. I would assume that the motor unit, i. e. the individual motor nerve fiber together with the multitude of muscle fibers it innervates would have properties similar to that described for the tenuissimus. As with other skeletal muscles, it is generally agreed that skeletal muscle fibers do not receive a direct sympathetic innervation (Bowman and Nott, 1969).

The main action of this muscle is in the flexion of the foot; secondarily, it also acts to extend the second digit and rotate the paw laterally. Sherrington (1910) noted that this muscle was involved in the reflex flexion of the hind limb. The muscle would contract in flexion and relax during the extension phase of the step-reflex. He also observed that during the standing reflex there is an absence of contraction in the tibialis anterior. In the same study, Sherrington reported on the tenuissimus muscle of the cat. It was very similar in its action to that of the tibialis anterior differing only as to the degree of contraction or relaxation.

The tenuissimus muscle (abductor cruris caudalis; Fig. 2) is a long slender muscle running from the second caudal vertebra to an insertion halfway down the leg on the fascia of the biceps femoris (Adrian, 1925). Its action is that of a weak abductor and extensor of the thigh as well

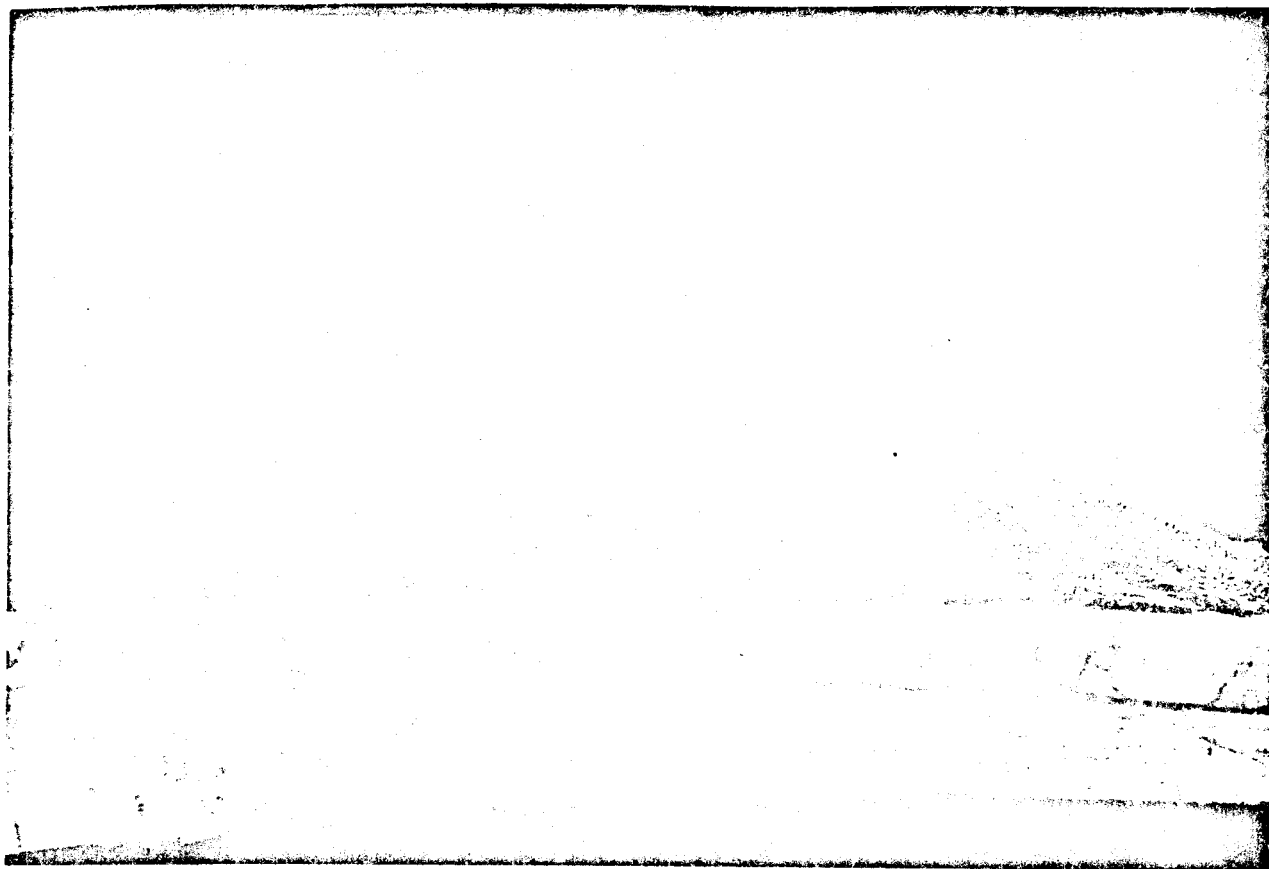

Figure 2. Central portion of the tenuissimus muscle with the very end of the main nerve and its branches.

as a flexor of the thigh. The muscle is absent in man and is not found in all cats. It varies from about 9 to 15 cm in length and its cross section contains about 1000 fibers. The muscle fibers are parallel; there are no tendonous intersections of any kind. Each fiber is on the average 17.3 mm long, with extremes from 13.0 to 25.5 mm. The mean diameter of each fiber is about 30 microns (Boyd, 1956).

The arrangement of the tenuissimus makes it a suitable muscle for illustrating the response of a complex muscle whose fibers do not stretch from end to end.

The spread of activity throughout the muscle when one point is stimulated is due to an excitation of nerve fibers which branch out in such a way that one fiber of the main nerve trunk may be connected with muscle fibers at either end of the muscle. The main nerve fiber divides into two branches which enter the muscle slightly proximal to its center, one passing upwards and the other downwards (Adrian, 1925). Brown (1913) has suggested the possibility that within the neuron there are units, the activation of which are "all or none" in character. This possibility was shown to be true in 1923 by Porter and Hart, who showed that the nerve-muscle responses were comparable to the "all or none" responses observed via reflex activity. Cooper (1929) concluded that each branch of the nerve supplies a chain of muscle fibers rather than a number of them side by side.

Thus, in a submaximal contraction both halves of the muscle may contract with each half contracting throughout its length, while in the course of a larger contraction more parallel chains are brought into action.

The nerve branch to the muscle fiber loses its myelin sheath before it penetrates the sarcolemma. Zacks and Blumberg (1961) observed terminal axon branches lying in depressions (primary synaptic clefts) in the sarcoplasmic surface. Overlying the terminal branches and intimately related to the axon membrane was a mass of Schwann cell cytoplasm that occasionally showed complex infoldings with the axon surface membrane. The primary synaptic clefts contained a frequently laminated and somewhat granular material of low electron density that has been called "ground substance" (deHarven and Coers, 1959), "basement membrane" (Robertson, 1960) or "amorphous surface material" (Zacks and Blumberg, 1961).

The motor endplates of the tenuissimus conform to the description given for other mammalian endplates (Boyd, 1956). Coers and Wolf (1959) estimated the mean diameter of the human limb muscle motor endplates to be $32.2 \pm 10.5 \mu$. Individual motor endplates ranged in diameter from 10 to 80μ . They were also able to demonstrate a close direct correlation between the diameter of the muscle fibers and their respective endplate diameter. Coers (1955) compared in the rabbit and monkey the size of

endplates in red muscle, the soleus vs. that of the endplates in white muscle, the anterior tibialis, and found the red muscle endplates to have a mean size significantly greater than that of the white muscle endplates.

Using rat muscle, Palade and Palay (1954) concluded that the axon ending anatomically appeared the same as that of central synapses. Reger (1957) compared the ultrastructure of normal and denervated neuromuscular synapses in the mouse. Forty-eight hours following the denervation there was a retraction of the sarcolemma with considerable lysis observed at the axon and its contents. The normal neuromuscular synapse consisted of a sarcoplasmic sole with a large accumulation of mitochondria and small granules. The axon and the muscle were separated by a cleft of about 500 - 700Å. Synaptic vesicles, mean diameter 300Å, were particularly numerous at the periphery of nerve endings in the region facing the muscle fiber, where they numbered up to $250/\mu^2$ (deHarven and Coers, 1959).

Bennett (1956) postulated a membrane vesiculation mechanism for transfer of substances across cell membranes. De Robertis (1958) amplified this concept to suggest a mechanism for release of neurotransmitters via vesicular interaction of pre- and post-synaptic membranes. A number of neurophysiologists and pharmacologists have modified this proposed mechanism in describing the transmitter release mechanisms at synaptic junctions (Katz, 1958, 1962; Bass and Moore, 1966; Hubbard et al., 1967).

Reports on the ultrastructure of the neuromuscular junction never describe whole synaptic vesicles crossing synaptic clefts. What's more, what is the substance that lies within the synaptic cleft? Is this substance or fluid comparable to normal extra-cellular substance? What in fact happens to vesicles once they reach the presynaptic membrane or are expelled from the nerve terminal? What effect do drugs have on the "normal" anatomy of the neuromuscular junction?

PHYSIOLOGY

Basic Properties of Nerve-Muscle Membranes and of Transmission

At the beginning of this century, Bernstein (1902) published his membrane theory of nervous conduction. Since the action potential involves a reversal of membrane potential and is not simply a neutralization as Bernstein proposed, his theory has had to be modified in one important respect. But, in general, Bernstein's theory has stood the test of time better than most biological theories and the underlying assumptions about the role of the membrane, which probably seemed speculative to Bernstein's contemporaries would now be accepted without question by the majority of physiologists (Hodgkin, 1965).

In 1949, Hodgkin determined by biochemical analysis that the fluid external to either a nerve or muscle contained high concentrations of sodium and chloride, while the intracellular ionic composition showed a higher concentration of potassium and various organic anions. There are several factors which may affect the rate of exchange of these ions across their respective membranes. One of these is the actual potential difference or electrical gradient across the cell membrane. This produces a tendency for equilibration of ions according to their respective electrical nature. As a result, cations entering the membrane are attracted by the negative charges within the cell and in fact tend to be driven into the cell; while anions within the cell for the same reason tend to pass to the outside through the cell membrane. Various studies have shown that the cell membrane in

its resting state is selectively permeable to the potassium ion which results in a gradual loss by leakage of potassium to the outside of the cell. These same studies have shown that the nerve cell membrane exhibits slight permeability for either the sodium or chloride ion but that such is not the case for the larger organic anions. On the other hand, Hodgkin and Horowicz (1959) have demonstrated that the muscle cell membrane exhibits a greater permeability to chloride ions than is evidenced at the nerve cell membrane. To maintain a relatively steady state of potassium ions within and sodium ions without the cell, a metabolic pumping mechanism, the sodium pump, has been suggested. If one calculates the potential differences across these cell membranes by using either the Nernst or Goldman equation, one can see a rather good agreement with the empirical observations obtained using standard electrophysiological procedures.

The generation of a nervous impulse is like starting a fire, i. e. it requires a spark which in the case of the membrane is constituted by the depolarization. This depolarization is of such a nature that once it reaches threshold, a non-decremental, "all-or-nothing" phenomenon occurs, the action potential. The development of this initial depolarization to threshold may be electrical, chemical, or mechanical in nature depending upon the specific sensitivity of the membrane components involved. In the case of the neuromuscular junction the postsynaptic membrane - the endplate area - is strictly chemically sensitive (Katz, 1966). Having reached

threshold via depolarization, the cell membrane develops a high specific permeability to sodium ions resulting in the influx of the positively charged sodium ion within a fraction of a millisecond. The increased permeability to sodium is said to be due to a physical-chemical change of the membrane. As a consequence sodium ions are carried inwardly along their steep electro-chemical gradient, rapidly discharging the cell membrane in a feed-forward type of action which progressively self-regenerates their transfer. The net result is the production of the "overshoot" type of potential, i. e. a reversal of potential approximating but never reaching the sodium equilibrium potential (E_{Na}). This self-regenerating increase in sodium permeability beginning at threshold does not continue indefinitely. There is an inactivation process whereby this transfer process begins to fail as the action potential reaches its peak; the nature of this inactivation process is not understood. It has been shown that the amplitude of the action potential is determined by the ratio $[Na_o]$ to $[Na_i]$ (Hodgkin and Katz, 1949).

It must be kept in mind that potassium ions tend to leave the cell not only in the resting state; but moreso, also during the action potential. As the action potential tends towards the E_{Na} , a similar increase in permeability, this time to potassium ion, occurs causing an

increased leakage of potassium out of the cell. In time the Na-pump will act to restore any imbalance in Na/K concentrations within the cell. The magnitude of the net ionic fluxes was shown to be equal to 3 to 4 pmoles/impulse-cm² which is greater than twice the safety factor for conduction (Hodgkin, 1958). Also aiding in the movement of potassium out of the cell is the increased electrical gradient resulting from the elevated sodium ion concentration. Combining with the decreased sodium permeability and increased activity of the sodium-pump, the outward movement of potassium returns the membrane potential back to its resting level (Hodgkin, 1967) - a negative feedback process (Katz, 1966). It should be noted that at the termination of the falling phase of the action potential, i. e. during repolarization, the action potential may or may not have a positive after-potential (a potential more negative than the resting potential). The positive after-potential, if it occurs, depends on the resting membrane potential of the cell being studied. For example, the muscle membrane would not normally show a positive after-potential since the potassium equilibrium potential (E_K) approximates the resting potential. However, at most other excitable membranes a positive after-potential is seen due to the E_K being more negative than the resting potential and thereby pushing the action potential towards this value during repolarization (Hodgkin, 1951). Also, in excised preparations the recorded resting potential is usually more positive than that of the normal tissue due to a non-steady state of the excised

preparation (Katz, 1966). One can induce a positive after-potential in any preparation by simply depolarizing that cell to a level more positive than the resting potential (by using a voltage clamp) and therefore away from the E_K (Cole, 1961). In using the cut fiber preparation one can readily see a positive after-potential since the resting potentials are in the range of -40 to -50 mV compared to the normal potential of -60 to -70 mV.

During the time of the positive after-potential a state of refractoriness can be noted at the membrane. At this time the membrane permeability to sodium ion is minimal while that towards potassium ion is still quite apparent - trying to push the potential toward the value of the E_K . However, this refractory state is short lived allowing the normal regenerative mechanism of the action potential to proceed once the membrane potential has returned to its resting state (Hodgkin, 1967).

There are several stages of neuromuscular transmission that occur during the transfer of information from nerve to muscle. Altogether, six stages may be distinguished: 1) the nerve impulse; 2) nerve ending depolarization; 3) transmitter release; 4) endplate potential; 5) muscle action potential and 6) muscle contraction. It has been shown that even without a conducted nerve impulse, the transmitter quanta, i. e. the mepps, act across the synapse on the postsynaptic membrane. But only after a nerve impulse has been generated which sufficiently releases enough transmitter to evoke a graded endplate potential of threshold magnitude

will a muscle action potential be propagated. There is a certain delay between nerve impulse and the recording of an endplate potential. This delay has been attributed mainly to the release mechanism for the transmitter (Katz and Miledi, 1965). However, other factors that may be suggested to contribute to this delay are the actual diffusion of the transmitter across the junctional cleft and also the receptor activation or permeability changes. Through the combined efforts of several researchers the nature of the transmitter at the neuromuscular junction has been suggested to be cholinergic.

Concept of Neurohumoral Transmission

The idea of neurohumoral transmission was first proposed by T.R. Elliott (1905). He was impressed with the similarity in action of adrenalin and the effect of stimulation of sympathetic fibers. As a result, he proposed that adrenalin may be the transmitter from sympathetic nerves to their effector organs. A comparable role was later suggested for acetylcholine in parasympathetic nerve endings by Hunt and Taveau (1906); this concept was greatly extended by Dale (1914). These proposals were fortified by Otto Loewi's (1921) experiments on the frog's heart vagus and on the perfusate in which Loewi has demonstrated the presence of the "Vagus-Stoff". Finally, in 1929, Dale and Dudley isolated acetylcholine from the spleen establishing it as a naturally occurring substance and

concluded that acetylcholine was the parasympathetic transmitter. Although the concept of neurohumoral transmission appeared acceptable to many physiologists in the case of the autonomic nervous system, it was not received favorably when it was proposed for the neuromyal junction. However, in 1936, Dale, Feldberg, and Vogt showed that the chemical concerned with neuromuscular transmission was also acetylcholine (cf. Karczmar, 1970, for the history of the development of the concept of neuro-transmission). The nerve fibers innervating skeletal muscle have been classified as cholinergic; since their action is not blocked by atropine nor is their action mimicked by the alkaloid muscarine their effector site has been classified as nicotinic in its response.

Cholinergic nerve endings contain many enzymes of which two are of prime importance. Choline acetylase (or choline transferase) synthesizes acetylcholine by transferring acetyl groups from CoEnzymeA to choline. This enzyme is contained within the cytoplasm of the axon in intracellular particles other than the vesicles (Hebb and Smallman, 1956). Choline is normally present in sufficient plasma concentration to support optimal synthesis no matter how heavy the frequency of nerve impulses might be (Bowman, 1962). Choline is unable to penetrate nerve axons along their length so that a specific choline transport mechanism within the nerve terminal is required. This transport mechanism carries extracellular choline to the terminal where it is acetylated by choline acetylase. The

second prime enzyme which is contained in the nerve terminal is acetylcholinesterase (AcChE). This enzyme is capable of rapidly hydrolyzing and thereby inactivating acetylcholine (ACh). AcChE unlike choline acetylase has been localized at the external surface of the pre- and post-synaptic membranes (Koelle and Friedenwald, 1949). A third location has been suggested (Mann, Tennenbaum and Quastel, 1938); AcChE may be located inside the nerve-endings where it is possibly associated with the outer surface of the vesicles or the inner surface of the presynaptic membrane. There is, however, a distribution difference depending upon the tissue studied. At the neuromuscular junction most of the enzyme AcChE is located postsynaptically (Couteaux, 1958; Riker, 1960; Barnett, 1962). Koelle and Steiner (1956) have suggested that external AcChE is the functional type, which acts to hydrolyze ACh released during transmission; the internal AcChE is the recently synthesized enzyme on its way to the functional external sites. These two enzymes, choline acetylase and AcChE, are probably formed in the cell body and are carried down the nerve-endings by the axoplasmic current streaming down each fiber (Hebb and Waites, 1956).

Once the transmitter ACh has been synthesized it may be distributed at the nerve terminal into various compartments (Birks and MacIntosh, 1961). It is found that only part of the transmitter present can be released by nerve impulses. At the rat diaphragm as much as 75 - 85% of the total

present is releasable (Potter, 1968). Potter also reported that in the release process the most recently synthesized ACh is released first. What's more, the transmitter that is releasable is not apparently equally available. This has been demonstrated by stimulating nerves at frequencies other than physiological; it was observed that the amount released per impulse is not constant but is dependent upon the frequency of stimulation (Starne, Hedqvist and Bygdeman, 1969; Folkow, Haggendal and Lisander, 1968). Using a technique in which trains of endplate potentials (epps) are observed, a fast depletion of ACh output during the beginning of such a stimulation seems to occur, leveling off to a mobilized release level characterized by a slower depletion of ACh (Liley and North, 1953; Elmqvist and Quastel, 1965). These latter results point to a further compartmentalization of the terminal into a smaller, readily releasable store that can be maintained by a larger less mobile store (Perry, 1953; Birks and MacIntosh, 1961; Elmqvist and Quastel, 1965). The most mobile store may be the closest to the presynaptic membrane (Curtis and Eccles, 1960), but this suggestion has not yet been shown to be true.

Transmitter Release

The transmitter having been compartmentalized is ready for release. But there are two different manners in which this is accomplished, namely spontaneously or by nerve impulse. Spontaneous transmitter release (originally classified as "biological noise") is recognized today to be the

origin of the miniature endplate potentials (mepps) or quanta (Fatt and Katz, 1952; Katz, 1962). Miniature endplate potentials have been detected at all vertebrate nerve-muscle junctions thus far studied including those at both red and white muscles (Fatt and Katz, 1952; Boyd and Martin, 1956a; Brooks, 1956; Liley, 1956a; Burke, 1957; Takeuchi, 1959; Elmqvist, Johns and Thesleff, 1960).

It has been found that mepp amplitudes recorded from the same cell or from a population of cells show only a small variation about the mean with a certain incidence of "giant" potentials whose amplitude has been attributed to be a multiple of the mean (Fatt and Katz, 1952; Liley, 1956a; Boyd and Martin, 1956a). The variation about the mean has been suggested to be due to differences in the postsynaptic properties of the impaled cell, especially the cell diameter (Katz and Thesleff, 1957). Because of this stability in amplitude it was then possible to divide evoked synaptic potentials (epps) into their proposed component units, namely the mepps or quanta. Various methods have been employed to produce such a situation, but the most effective involved changing the composition of the perfusion solutions by lowering $[Ca^{++}]$, raising $[Mg^{++}]$, or by combining these procedures (del Castillo and Engback, 1954). The value of this procedure will be pointed out later in speaking of determination of the quantal content of epps.

Changes in mepp amplitude can reflect either a pre- or post-synaptic

action, or both actions. Usually a postsynaptic action is the primary cause of such an effect. In measuring mepp amplitude one should also inspect possible changes in the rise-time, i. e. the time interval between the beginning of the potential and the attainment of its peak amplitude, and in the half-decay time, i. e. the time interval between the peak amplitude and the decay to 50% of this amplitude. A change in the rise-time of the mepp may suggest a difference in the binding properties of the postsynaptic receptor to the transmitter or a change in the rate of release; whereas a change in the half-fall may indicate a difference in the passive membrane properties of the postsynaptic membrane or an anti-AcChE action.

Drug-induced changes in mepp frequency, on the other hand, are usually attributed to a presynaptic action (Katz, 1962). Parameters such as temperature changes, osmotic changes within the bathing solution, or varying the resting membrane potential can all modify the frequency of mepps (Fatt and Katz, 1952; del Castillo and Katz, 1954a; Furshpan, 1956; Liley, 1956a; Hubbard et al., 1967; 1968). Ionic balance of the contents of the perfusion fluid also affects the normal frequency; the concentration of calcium is especially important. Mepp frequency is reduced but not abolished in the absence of calcium in the bathing medium, while the production of evoked release of ACh by nerve impulses is completely abolished (del Castillo and Stark, 1952; Liley, 1956a; Hubbard, 1961; Hubbard et al., 1968). Although statistically significant changes from

control can be induced by certain drugs, only by elevating external potassium ion concentration is a marked increase of the release obtained.

Analysis of the mepp frequency leads to a Poisson distribution (Fatt and Katz, 1952). A Poisson distribution is obtained when the probability of the occurrence of an event is constant over appreciable periods of time, and the chance of an event occurring is unaffected whether other similar events occur or not (Hubbard, Llinas and Quastel, 1969). Gage and Hubbard (1965) utilized a method for determining that mepps do in fact follow a Poisson distribution by applying data to the Poisson Generating Function given by the relation:

$$t = e^{-m} \left(\frac{m^n}{n!} \right)$$

where t is any interval of time during which ' m ', a mean number of Poisson events is expected to occur; ' n ' is the actual number of events that do occur. Another useful indicator that the distribution obtained is indeed Poisson is the equality between the mean of a series and its variance (cf. below, under methods).

The second type of transmitter release is that due to evoked stimulation resulting from the nerve impulse. The resultant potential recorded at the neuromuscular junction has been termed the endplate potential (epp). However, in order to record this response one must first eliminate the muscle action potential and the muscle contraction. This can be accomplished by using pharmacological blocking agents, varying the extracellular ionic concentrations, or using surgical techniques. The epp is a local depolari-

zation of the motor endplate brought about by the action of ACh. Fatt and Katz (1952) have demonstrated that at rest, the recorded membrane potential of the endplate does not differ from that recorded elsewhere along the muscle membrane. On the other hand, only the endplate area is especially sensitive to the action of ACh in the normal muscle. This is not the case, however, in chronically denervated muscle, in which the entire muscle surface becomes ACh sensitive (Thesleff, 1960). This specific area of the postsynaptic endplate membrane which reacts to ACh, i. e. the cholinergic receptor, has most recently been suggested to have a molecular weight in the range of 40,000 and to be proteo-lipid in nature (Changeux, Kasai and Lee, 1970; Miledi, Molinoff and Potter, 1971; and de Robertis, 1971). The interaction of acetylcholine with this receptor causes a permeability change in the membrane such that its selectively permeable nature to cations is diminished. The resultant potential change is unlike that seen in the case of the nerve or muscle action potential, but is rather a non-reversing potential that tends towards an equilibrium level. This equilibrium level has been reported to be in the range of -10 to -20 mV in frog muscle or frog ganglion (Blackman, Ginsborg, and Ray, 1963; del Castillo and Katz, 1954; Nishi and Koketsu, 1960; and Takeuchi and Takeuchi, 1960). The epp also differs from the nerve or muscle action potentials in that it is graded, rather than "all-or-none" in nature. If this depolarization is great enough and reaches a

threshold level, it initiates a propagated muscle action potential. The amount of ACh released to produce this chain of events is usually about five-fold in excess of that required; but the excess is easily hydrolyzed so that the endplate can become repolarized before the end of the refractory period of the muscle fiber.

The successful production of an epp is inherently involved with the mechanism by which ACh is released. A simple definition of increased release of transmitter would be facilitation, whereas depression would signify a decrease in quantal release. As mentioned earlier, the release of ACh by nerve impulses at the vertebrate nerve-muscle junction is impossible in the absence of calcium (del Castillo and Stark, 1952; Liley, 1956; Harvey and MacIntosh, 1940). Hodgkin and Keynes (1957) suggested that the depolarization of the squid giant axon by the nerve action potential was produced by influx of sodium ions, accompanied by some calcium ions and speculated that the calcium ions might lead to synaptic vesicle breakdown and to the release of ACh. They have demonstrated that at rest there is very little free calcium ions in the axoplasm, but during activity there is a sharp rise in calcium influx. During rest, the calcium ions that have entered are slowly pumped out. Evidence for calcium involvement in release was further established since the amount released varied over a wide range with the concentration of calcium in the bathing medium (del Castillo and Katz, 1954; Hutter and Kostial, 1954; cf. Karczmar, 1967).

Where and when does calcium affect the release? There is evidence that calcium occurs as a bound complex CaX in the ratio of 3 or 4 molecules to each binding site on the external surface of the terminal membrane. This complex is believed to accelerate the release process with each nerve action potential (Dodge and Rahaminoff, 1967). Using this model, Hubbard et al. (1968) have developed a kinetic scheme to explain the effects of calcium ions and magnesium ions on both spontaneous and evoked release. It should be pointed out that the effects of calcium on transmitter release as measured by the increase in quantal content of the epp cannot be due to a calcium-mediated sensitization of the endplate to ACh, as high calcium does not enhance, but depresses the endplate sensitivity to ACh (del Castillo and Stark, 1952; Lundberg and Quilisch, 1953; Takeuchi, 1963).

The most recent proposal for calcium entry into the nerve terminal involves cyclic adenosine-3'5'-phosphate (C-AMP) (Rasmussen and Tenenhouse, 1968). The reported small increase in mepp frequency induced by norepinephrine (Krjnevic and Miledi, 1958; Jenkinson, Stamenovic and Whitaker, 1968; and Kuba, 1971) may constitute the evidence linking C-AMP with the transmitter release at the neuromuscular junction. Indirect evidence includes the increased frequency of mepps following caffeine (Hofman, 1969). The strongest evidence is that reported by Goldberg and Singer (1969) using C-AMP analogues. Might it be possible that C-AMP is the compound "X" to which 3 or 4 molecules of Ca^{++} are attached at the release site?

The time component at which calcium affects the release process was limited to the period of 1 to 2 msec during which the increase in the concentration of external calcium occurs prior to the invasion of the nerve terminal by the nerve action potential (Katz and Miledi, 1965, 1967). These data indicate that calcium ions are involved in an essential step between the membrane depolarization and ACh release which is not related to the effects on the electrical properties of the nerve terminal.

Mathematical Interpretations of Transmitter Release

There are various methods available for estimating evoked transmitter release. In all cases however, when determining a presynaptic release process at the mammalian neuromuscular junction one must base the analyses upon results obtained postsynaptically - assuming that the postsynaptic potential is an accurate relative assay of transmitter release (Bloedel, Gage, Llinas and Quastel, 1966). The three main methods employed for determining quantal content are: 1) The Direct Method; 2) The Variance Method; and 3) The Method of Failures (del Castillo and Katz, 1954; Martin, 1955; Boyd and Martin, 1956; Liley 1956; Dudel and Kuffler, 1961; Kuno, 1964; Elmqvist and Quastel, 1965). Using the variance method as described by Elmqvist and Quastel (1965) the effects of catechol upon transmitter synthesis, storage, and mobilization have been analyzed in this dissertation.

PHARMACOLOGY

There are various mechanisms which have been suggested for the actions of drugs at the neuromuscular junction. These can be broadly divided into pre- and post-synaptic mechanisms. The presynaptic mechanisms include: 1) reduction of transmitter release; 2) prevention of transmitter release and 3) increase of transmitter release. The post-synaptic mechanisms include: 1) motor endplate block; 2) sensitization; 3) anti-cholinesterase activity and 4) membrane characteristics.

Presynaptic Mechanisms

A reduction of transmitter release from the nerve can be accomplished most dramatically with a group of compounds known as the hemicholiniums. These compounds, originally synthesized by Long and Schueler (1954) have been demonstrated to have a variety of actions; in lower concentrations, they appear to inactivate specifically the choline-carrier mechanism. This system is responsible for the transport of extra-cellular choline across the membranes of cholinergic nerve-endings to the intracellular site of its action. The paralysis that is produced is delayed in onset, dependent upon the frequency of stimulation, and antagonized by choline. Compounds having a similar action have been synthesized and include triethylcholine, which can be acetylated in the nerve terminal and released as a false transmitter (Bowman and Rand, 1961).

The prevention of transmitter release can be brought about in at least three ways. If one modifies the ionic concentration of the bathing medium, specifically either decreasing the calcium concentration or raising the magnesium concentration or by a combination of these two, one can interfere with both evoked as well as spontaneous release. Second, the local anesthetics such as procaine have also been demonstrated (Harvey, 1939) to decrease the amount of ACh released. The problem with procaine or many other compounds is that they have a multiplicity of actions so that usually the more prominent action on the motor endplate rather than at the nerve terminal is observed (del Castillo and Katz, 1957). The third manner in which release can be prevented is with botulinum toxin (Brooks, 1956). In nerve-muscle preparations poisoned with this toxin, nerve conduction is not affected and the muscle still responds to ACh injected close-arterially; but, release of transmitter is prevented. One can also record a decrease in the frequency of mepps without a change in their amplitude after application of this toxin.

An increase in the release of transmitter output (facilitation) from the nerve can, like its prevention, be brought about in a variety of ways; in all cases, the phenomenon most readily noted is the increase in the frequency of mepps. Changing the ionic concentration of the bathing medium by increasing the external calcium concentration causes a large increase in the release of transmitter. Katz and Miledi (1965) and Elmquist and Feldman

(1965) applied calcium ions electrophoretically to the frog nerve terminal and the rat diaphragm; in either case, a release of transmitter from the terminals could be demonstrated. They also noted that lack of calcium had no effect upon propagation of the nerve impulse. These results suggest that ACh release is determined by intracellular ionized calcium and that the calcium is derived from the influx as well as from the variable membrane store of bound calcium which is controlled by the membrane potential (Karczmar, 1967).

Increasing extracellular potassium ions (Liley, 1956) also causes an increase in transmitter release; this increase had been attributed to the accompanied membrane depolarization this procedure produces.

Certain compounds have been shown to cause a small but statistically significant increase in the frequency of mepps (Blaber and Christ, 1967). These compounds, eg. edrophonium, neostigmine, etc., have been suggested to produce their facilitatory action by causing a repetitive firing in the nerve terminal, and consequently in the muscle as well (Riker, Roberts, Standaert, and Fujimori, 1957). Prior to the report of Blaber and Christ (1967) facilitatory activity has been compared with anti-AcChE activity and these two have been found to go hand in hand (Kuperman, Gill and Riker, 1961).

Sodium has also been suggested to be involved with the release of ACh from the terminal (Birks, 1963; Gage and Quastel, 1966; Birks et al., 1968). The significant role for sodium may be that of maintaining the available

store of transmitter (Katz and Miledi, 1967; Blaber, 1970).

The nerve terminal action of a drug was first proposed long before the ability to measure mepps. Feng (1936) suggested that "a sympathetic action occurs only with indirect stimulation which is of the nature of a calcium mobilization, at any rate an ionic readjustment." Masland and Wigton (1940) and later Feng and Li (1941) described a method for detecting the activity of motor nerve terminals in the cat by means of recording the antidromic firing in the ventral root. The principle of the method is that when a physostigmine-like drug is administered, a post-stimulus repetition arises from the motor nerve terminals and can be detected by recording from appropriate ventral root filaments. This signals that the drug has acted on the nerve endings (Riker and Okamoto, 1969). Using this technique, Werner (1960) proposed a mechanism to explain facilitatory drug action; this action causes a potentiation of the isometric contractile response of the muscle, stimulated through the nerve, singly and maximally, as well as constitutes the basis of anti-curare and anti-myasthenic activity (Riker and Standaert, 1966). Werner (1960) postulated that facilitatory drugs enhance the capacity of the unmyelinated terminal to interact with the main axon. The following year Werner (1961) demonstrated that ephaptic transmission was not involved in facilitatory action and that an antidromically propagated action potential did originate in the nerve terminal. Riker and Standaert (1966) further defined the mechanism of facilitatory drug action as an

augmentation of the negative afterpotential in the unmyelinated segment of the axon, at a point close to the myelinated portion which caused a triggering of the generation for post-tetanic repetition. The initial studies using drugs that led to this kind of an idea for facilitation were those of Riker and Wescoe (1946) who demonstrated that neostigmine can directly depolarize neuromuscular junctions causing excitation independent of cholinesterase action. In developing these concepts Riker used derivatives of neostigmine, 3-hydroxy PTMA (phenyltrimethylammonium) and 3-hydroxy PTEA (phenyltriethylammonium), which were able to produce twitch potentiation, an anti-curare effect and very little anti-cholinesterase action; they did not cause contractions, fasciculations, or neuromuscular blockade (Riker and Okamoto, 1969). Koelle (1962) has suggested that acetylcholine might act to cause facilitation of the nerve terminal after an anti-cholinesterase had been used to prolong its half-life. Hubbard (1965) and Blaber and Christ (1967) found however that ACh did not increase the frequency of mepps. In other studies, Ciani and Edwards (1963), Martin and Pilar (1963) and Riker (1966) have determined in various ways that ACh depresses rather than facilitates motor nerve terminal function. Thus, the amount of ACh released is mainly dependent upon the degree of depolarization produced by the nerve action potential as it invades the terminal; it does not depend on the ACh which may be present in the synaptic cleft. The resting potential of the terminal therefore determines the size of the presynaptic potential as well as the

resultant epp (Hubbard and Willis, 1962a, b). In fact, by hyperpolarizing the presynaptic membrane one can cause an enhanced release of ACh. Hubbard (1970) concluded that Riker's hypothesis of junctional transmission should be abandoned since no local potentials have been detected within motor nerve terminals.

It has been suggested that the depolarizing compounds, succinylcholine and decamethonium, may act at the first node of Ranvier to cause a lowering of the stimulation threshold. The ensuing potentials are then able to propagate more easily into the nerve terminal (Hubbard, Schmidt and Yokata, 1965; Blaber and Goode, 1968). This facilitatory action of the depolarizers is however, quite dose dependent, since a slightly higher dose of the compound will lead to depression and block. This possible site of action has been suggested to be one of the multiple cholinceptive sites at the neuromuscular junction by Blaber and Karczmar (1967). They suggest five possible sites, three of which are involved in transmitter release. All of these have been already mentioned but a brief enumeration of the three sites may be in order. First, a choline carrier site is present within the terminal. Second, the motor nerve terminal is the site for production of antidromic discharges in the motor nerve following orthodromic stimulation associated with facilitation of transmission. Third, the motor nerve terminal has another site at the first node where depolarization may be also associated with facilitation. The authors carefully point out that: "A drug that is active at one site acts

in some degree at all other sites and may act as an agonist at some sites and as an antagonist at others".

While subsequently more sites of pre- as well as of post-synaptic action were more recently suggested in this laboratory (Karczmar, 1967b; Karczmar et al., 1970; Karczmar and Nishi, 1971), I am interested in at least one additional pre- and post-synaptic site that may be adrenoceptive in nature.

Presynaptic Adrenoceptive Site

In 1967, after many previous papers relating to the subject (cf. Bowman and Raper, 1966) Bowman suggested that at the neuromuscular junction there may be adrenotropic receptors which can be classified according to the subheadings of alpha and beta after Ahlquist (1948). The alpha-receptors appeared to be present in the motor nerve endings and their activation would facilitate neuromuscular transmission by increasing the release of transmitter by nerve impulses. The beta-receptors appeared to be present in skeletal muscle fibers and their activation will either cause a facilitation or depression of the muscle contraction.

The first report of a facilitatory action by the sympathomimetic amines was by Panella (1907) as he demonstrated that epinephrine had an anti-curare effect. Bowman and Nott (1969) have reviewed the literature listing confirmations of this anti-curare action in the amphibian, mammalian, and avian muscle. The characteristics of this particular anti-curare action

suggest that it is mediated through alpha-adrenoreceptors, as it is produced by epinephrine and to slightly lesser extent by norepinephrine while isoproterenol is ineffective. Furthermore, the anti-curare effect is blocked by the alpha-receptor blocking drugs (Maddock, Rankin and Youmans, 1948) but not by the beta-receptor blocking drugs (Bowman and Raper, 1966).

It has been demonstrated that epinephrine and norepinephrine exert a presynaptic action since each increases the amplitude of epps produced by motor nerve stimulation in both frog and rat muscle when neuromuscular transmission was depressed by curare or by elevating the concentration of magnesium ion (Hutter and Loewenstein, 1955; Krnjevic and Miledi, 1958; Jenkinson, Stamenovic and Whitaker, 1968; Kuba, 1970). Kuba demonstrated that norepinephrine did not affect the amplitude of iontophoretically applied ACh, while both epinephrine and isoproterenol increased this response. All of the authors were able to demonstrate an increase in the frequency of mepps only by the compounds classified as alpha-receptor stimulants. On the other hand, norepinephrine did not increase the amplitude of the mepps while the compounds possessing beta-receptor stimulant activity did. Jenkinson, et al. (1968) have demonstrated that the increase in amplitude of epps produced by norepinephrine in frog muscle was blocked by phentolamine but not by propranolol.

A prejunctional action of epinephrine is supported by the observation that during the epinephrine-induced increase of the partially curare-blocked

contractions evoked by motor nerve stimulation, contractions produced by close-arterially injected ACh and the endplate depolarizations produced by succinylcholine were slightly inhibited (Bowman and Raper, 1966).

Indirect evidence suggests that the increase of ACh release produced by epinephrine is the result of a hyperpolarizing action on the motor nerve ending (Krnjevic and Miledi, 1958). Epinephrine also causes hyperpolarization of isolated mammalian "C" fibers (Goffart and Holmes, 1962).

Other evidence that epinephrine may in general cause hyperpolarization of nervous tissues comes from the experiments of deGroat and Volle (1965) who showed that epinephrine increased the demarcation potential of ganglion cells. This postsynaptic hyperpolarizing action depresses ganglionic transmission, but, like the anti-curare action of epinephrine, it is inhibited by the alpha-receptor blocking agents. It may be possible that epinephrine acts at the first node of Ranvier (Bowman and Nott, 1969) to cause hyperpolarization.

Another facilitatory action of epinephrine is demonstrated by its ability to potentiate the twitch augmentation and repetitive firing in both nerve and muscle produced by the anticholinesterase or the depolarizing drugs (Bulbring and Burn, 1942; Blaber and Bowman, 1963; Bowman and Raper, 1966). Bowman and Raper's results had demonstrated further that alpha-receptor blocking drugs prevent this potentiation which they classified as being mediated through alpha-receptors. In contrast to the results of

Bowman and Raper, Breckenridge et al. (1967) demonstrated that the potentiation of neostigmine by epinephrine was blocked by propranolol, a beta-receptor blocking drug, and concluded that this effect was therefore mediated through beta-receptors.

In this same study, Breckenridge et al. (1967) pointed out that epinephrine stimulated the formation of adenosine-3', 5'-phosphate (C-AMP) within many tissues. This action of epinephrine on C-AMP has been thoroughly investigated by Sutherland and Robison (1966). Breckenridge et al. (1967) also indicated that C-AMP levels can be raised with theophylline, which inhibits hydrolysis of the nucleotide by a phosphodiesterase. From their results they concluded that the effects of epinephrine either at the nerve terminal or the muscle may be mediated by C-AMP; and that this mediation is via beta-receptor interactions.

There are many other possible mechanisms of action at the nerve terminal or other explanations for the mechanisms thus far proposed. However, I should like to leave the nerve terminal and begin to describe some of the concepts that have been proposed for postsynaptic mechanisms.

Postsynaptic Mechanisms

In 1851, Claude Bernard published his classical experiments on the site of action of curare in the frog. In 1935, King isolated D-tubocurarine from curare and this stimulated a greater interest into the mode of action of neuromuscular blocking agents and resulted in major advances concerning

the physiological processes underlying the transmission of the excitation wave from motor-nerve endings to voluntary muscle. The mechanism by which curare produces its motor endplate block is generally described as an interference with the action of ACh at the motor endplate so that a muscle contraction is only elicited by a quantity of ACh greater than normal (Bowman, 1962). Curare prevents the response of skeletal muscle to motor nerve impulses and to injected ACh; during the paralysis, nervous conduction continues and the muscle fibers themselves retain their sensitivity to direct stimulation. Paralysis can be maintained with curare; throughout this paralysis as well as at its height, the output of ACh is not significantly altered (Dale, Feldberg and Vogt, 1936). Similarly, Martin (1955) and Beranek and Vyskocil (1967) have not shown any significant reduction of the quantal content of an epp in the presence of curare. On the other hand, Hubbard, Wilson and Miyamoto (1969) have demonstrated using the cut fiber technique that curare decreases the quantal content, readily releasable stores, and mobilization while increasing the probability of release at the rat diaphragm phrenic-nerve preparation. Auerbach and Betz (1971) using the voltage clamp technique were unable to demonstrate a significant decrease in the quantal content and attributed the results of Hubbard et al. (1969) to a technical problem of electrode positioning. It was concluded by these authors that if curare affected transmitter release at all, its effects must be much smaller than its well-known postsynaptic action.

A second mechanism involved with postsynaptic action is that of the depolarizing drugs. In general, these compounds produce an electrical inexcitability, arising as a result of a prolonged depolarization in the region of the motor endplate (Bowman, 1962). ACh in high concentrations has long been shown to produce neuromuscular block (Bacq and Brown, 1937). Due to its rapid hydrolysis by AcChE, ACh is not a useful blocking agent unless in the presence of anti-AcChE drugs; but in essence all of the depolarizing blockers act via this mechanism. The most active members of this group are decamethonium and succinylcholine, differing basically in their duration of action. Both compounds had originally, like curare, been assigned only a postsynaptic mode of action, but actions on the nerve terminal possibly explaining their initial facilitatory response have been proposed (Blaber and Karczmar, 1967a, b). Depending upon the animal species these agents in the process of their blocking action increase the threshold of ACh resulting in a "dual mode of action" block (Zaimis, 1953; Thesleff, 1955). This second postsynaptic process which appears to follow the initial depolarization and is inherent to the blocking action is a phenomenon termed "desensitization". This action differs from the competitive blockade seen with curare-like compounds since it is non-competitive and responds poorly to high concentrations of acetylcholine or to anticholinesterases (Karczmar, 1967; Kim and Karczmar, 1967).

A postsynaptic facilitatory action may be realized with the anti-ChE

agents. These compounds act to increase the amplitude of the twitch response resulting from indirect stimulation as well as to antagonize curare blockade by augmenting and prolonging the intracellularly recorded epp. The extent to which these compounds exert their pharmacological actions by inhibiting AcChE or ChEs generally is a subject of many investigations (Karczmar, 1967a and b). These agents have been used in the treatment of myasthenia gravis. Their successful history in certain cases is still due more to the art rather than the science of medicine (Thesleff and Quastel, 1965).

Postsynaptic Adrenoceptive Site

As stated earlier catecholamines have been demonstrated to have a presynaptic facilitatory action. These agents also possess a direct postsynaptic action. Epinephrine increases the contractions of non-fatigued fast contracting muscle when the stimulation is applied directly after full curarization or chronic denervation (Bowman and Zaimis, 1958). This action has been suggested to be due to the activation of the beta-receptor since among the catecholamines tested L-isoproterenol is the most potent. An interesting anomaly is that slow contracting muscles respond to sympathomimetic amines by depression rather than facilitation. It has been demonstrated that maximal isometric twitch tension, whether evoked by nerve stimulation or by direct stimulation of the fully curarized or by direct

stimulation of the chronically denervated muscle, is reduced by up to 20% (Bowman, Goldberg and Raper, 1962). It should also be noted that the sensitivity in response to catecholamines is much greater in the slow muscles than in fast muscles.

Another postsynaptic facilitatory action has been proposed which is different from this "pure" beta-receptor activation. Gruber (1914) was the first to suggest that the effects of epinephrine on muscle contractions may be secondary to the activation of the carbohydrate metabolism. Epinephrine and other catecholamines exert a pronounced stimulant effect on glycogenolysis in tissues (Cori, 1931). Epinephrine also stimulates the adenyl cyclase system, and it has been further suggested that adenyl cyclase may actually constitute the receptor for epinephrine (Robison, Butcher and Sutherland, 1967). Adenyl cyclase in turn catalyzes the conversion of adenosine triphosphate (ATP) to C-AMP; this reaction has been demonstrated to be increased by epinephrine in skeletal muscle (Posner, Stern, and Krebs, 1965). The cellular content of glucose-6-phosphate in skeletal muscle has also been shown to increase in the presence of epinephrine (Belford and Feinleib, 1964). Another group of enzymes stimulated by epinephrine in the presence of calcium ions are the phosphorylases (Ellis and Vincent, 1966). Bowman and Nott (1969) list the literature that gives supporting evidence to the concept that the effect of catecholamines on muscle glycogenolysis, like the aforementioned effect on non-fatigued muscle, is mediated via beta-

receptors. From this literature the reviewers propose that the production of C-AMP may be a common intermediate in the action of epinephrine on carbohydrate metabolism and on muscle contractility. They are careful to point out however that there is no evidence to support the concept that production of C-AMP is the final common step in the two processes, or that phosphorylase activation and increased cellular hexosephosphate levels are related as originally suggested by Ellis (1959).

Comparable biochemical studies involving these enzymes (adenyl cyclase, phosphorylase, etc.) and products (glucose-6-phosphate, cyclic-AMP, etc.) have not been reported using catechol.

Myasthenia Gravis and Facilitation

Myasthenia gravis is a disease involving a great weakness of the skeletal muscles. In a myasthenic this weakness becomes exacerbated with exercise. The first successful therapy of this disease was that of Remen (1932) and Walker (1935) using the anti-ChE neostigmine. There are several theories as to the etiology of the disease, but it is generally agreed that there may be different varieties of the disease rather than one unique illness.

One of the possible causes of the disease is an inability for a sufficient amount of transmitter to react with the postsynaptic receptor. Two general views have been proposed with regard to this lack: 1) there may be a desensitization of the endplate to the normal amount of released ACh (Grob,

Johns and Harvey, 1956); or 2) there may be a normally responsive endplate but less transmitter is being released (Desmedt, 1957). The success of anti-ChE therapy can readily be understood if one holds either of these views. However, on more than one occasion the myasthenic will either gradually develop a refractoriness to these agents or else be refractory to them from the very beginning. Another view that has been proposed is that the disease may have an autoimmune etiology and that the proper therapy would include immunosuppressive agents (Wolf et al., 1966). A possibility which I feel deserves more attention is employing agents that might facilitate transmitter release. Lower doses of anti-ChEs have been shown to have a direct presynaptic facilitatory effect (Blaber and Christ, 1967). Possibly the combination of these agents with sympathomimetic amines might prove to be an effective tool if there is a deficiency of transmitter.

History of Catechol

Catechol has had several synonyms through its course of study. The original German papers referred to it as "Brenzcatechin" or "Dioxybenzole". More recently it has been referred to as pyrocatechin, pyrocatechol, and finally simply catechol. Chemically, it is a dihydroxy substituted benzene with the two hydroxy substituent groups in ortho- position to each other; catechol is then 1,2-dihydroxybenzene (Fig. 2). Catechol is classified as a derivative of phenol (Fig. 4) which possesses most of its chemical properties.

Pharmacologically it is classified as the basic nucleus of the sympathomimetic amines. Bacq (1949) stated that the two phenolic groups of epinephrine are essential to the determination of the quality and intensity of sympathomimetic action of aromatic amines. He further concludes that the hydroxy group of epinephrine in the meta- position is more important than the hydroxy group in the para- position and, finally, that only catechol derivatives may be considered to be true sympathomimetic amines.

Catechol has not had any medicinal value as such, but some of its derivatives, eg. guaicol, guaicol carbonate and eugenol, as well as its mono-hydroxy parent compound, phenol, have been recognized as having medicinal uses. Phenol is one of the oldest antiseptics, having been introduced into surgery by Sir Joseph Lister in 1867. In addition to its bactericidal activity, which is not very strong, it has a caustic and slight anesthetic action. The bactericidal activity of most substances has been compared to phenol as a standard, and this activity is reported as the phenol coefficient. High concentrations of phenol will precipitate proteins, whereas low concentrations denature proteins without coagulating them. This denaturing activity does not firmly bind phenol and as a result it is able to penetrate the tissues. The action on tissues is a toxic one; pure phenol is corrosive to the skin,⁵ destroying much tissue, and may cause gangrene. As a rule phenols are inactive as bactericidal agents in the presence of serum, possibly because they combine with serum albumin,

and thus are not free to act upon the bacteria (Wilson and Gisvold, 1962). Clinically, phenol has been used via injection to cause nerve blocks in cases of spasticity or else via intrathecal injection for the relief of intractable pain. There are two possible explanations for its success in reducing spasticity. It may act by inhibiting the thin motor neuron fibers of the muscle efferents (gamma fibers) which adjust tone to various muscle lengths without inhibiting the larger alpha fibers that innervate striated muscle, causing a decreased reflex activity and therefore reducing spasticity. A second possibility is that phenol may block or partially block a percentage of nerves regardless of size (Talbott, 1965).

The metabolism of catechol or phenol is primarily via oxidation. Within the body catechol (a metabolite of phenol) is metabolized via four main pathways. 1) It is excreted as such in the urine; hydrolyzed human urine contains 5mg free catechol per liter whereas none is seen in unhydrolyzed urine (vonEuler and Lisbayko, 1959). Fiker (1955) points out that in the case of the workers exposed to benzene vapors their urine contains up to 100 mg/L. 2) Catechol can be oxidized to hydroquinone or hydroxyquinone. Hydroxyquinones can be further oxidized by either the cytochrome oxidase system or polyphenoloxidase. The resultant oxidized products are able to inhibit amine oxidase (Friedenwald and Hermann, 1942). 3) About 18% of the measurable metabolite has been identified as a conjugated product with sulfates to form mono-sulfuric acid esters. 4) The final and

most common mechanism, amounting to up to 70%, is a conjugation of catechol with glucuronic acid to form the monoglucuronide. It has been demonstrated that in the rabbit about 70% of orally administered catechol is excreted in one of these forms within twenty-four hours.

Many plant phenolics have been demonstrated to sensitize smooth muscle to epinephrine. A possible mechanism has been suggested which is the inhibition of the enzyme methyl transferase (Axelrod and Tomchik, 1958; LaBrosse, Axelrod, and Key, 1958). These authors have further demonstrated that epinephrine in vivo is inactivated by o-methyl transferase which methylated the phenolic hydroxyl group of epinephrine in the 3-position. Epinephrine however is not a specific substrate; other diphenols are also methylated by this enzyme. Therefore, catechol might act to sensitize the smooth muscle in vivo by competitive inhibition of the methyl transferase. From these experiments and the fact that in vivo iproniazid or any inhibitor of amine oxidase does not sensitize to epinephrine, the authors argued that methyl transferase is the enzyme which normally inactivates the bulk of the catecholamines in mammals. In the following year, Bacq (1959) determined that equimolar amounts of catechol inhibited the inactivation of epinephrine via inhibition in vitro of 50% of the o-methyl-transferase. He also suggested that this inhibition was probably responsible for the sensitization of smooth muscle to epinephrine by various ortho-, di-, or tri-phenols. Later Wylie, Archer, and Arnold (1960) in their study of various

polyhydroxyphenols determined that catechol at a dose of $5 \times 10^{-4} \text{M}$ was the least effective of the substances tested in inhibiting catechol-o-methyl transferase. Nevertheless, they suggested that polyhydroxyphenols are metabolized by methylation at the 3-position as is epinephrine, and as a result there is a competition resulting in a reduced methylation of epinephrine as the polyhydroxy phenols act as competitive substrates for the enzyme system. This is in agreement with the fact that the phenols augment the toxicity of the amines as this may be due to the phenol-induced increase in the life span of epinephrine.

The actions of phenolic derivatives, specifically catechol have been studied pharmacologically - the brain, the heart, the peripheral circulation, rabbit duodenum, guinea pig ileum, uterus, pupil, blood sugar, and skeletal muscle.

Catechol has been suggested to act as a convulsant which differs from other convulsants (namely, metrazol, strychnine, caffeine, and picrotoxin) having an anatomic site of action at the globus pallidus (Matsumoto et al., 1963; Matsumoto and Nishi, 1963a, b). A subconvulsive dose of catechol increased the fast components in the EEG of the globus pallidus and DOPA (10mg/kg, i. v.) decreased these components in this part. Norepinephrine, epinephrine, thiopental, and chlorpromazine augmented the catechol induced convulsion while pentobarbital was anti-convulsive. Reserpine had two different effects upon the catechol convulsion: 1) the convulsion was

suppressed in rats or rabbits pretreated with reserpine (10mg/kg) 30 minutes prior to catechol injection (0.1M, 3ml/kg, S. C.); 2) four and 24 hours after pre-treatment with reserpine the convulsion was augmented. The catechol convulsion was markedly suppressed 30 minutes after the administration of DOPA (150mg/kg, I. P.) or five minutes after the injection of dopamine (20µg/kg, i. v.). The augmentative action by reserpine of the catechol convulsion was inhibited by pretreatment of DOPA, and this suppressive action was antagonized by norepinephrine. Because of this these authors suggested that one of the augmentation-suppression mechanisms of the catechol convulsion depended on the relative relationship between norepinephrine and dopamine contents in the animal brain.

White and co-workers (1965) studied various drugs, including catechol with respect to reticular potentials evoked by peripheral stimulation and with respect to the rabbit EEG. Catechol (6-12mg/kg, i. v.) was similar to physostigmine (0.1mg/kg, i. v.) in abolishing midbrain reticular evoked responses and inducing EEG activation. The effect on the reticular evoked potentials lasted 4-16 minutes and recovery took 3-9 minutes, the EEG effect outlasting the abolition of the reticular response. Conduction was not impaired by these compounds. Attempts to block this effect of catechol with either phenoxybenzamine, pentobarbital, or scopolamine were unsuccessful, whereas scopolamine or atropine blocked both of the electrophysiological actions of physostigmine. Finally, catechol abolished or

markedly reduced a cortical evoked response and this block was not prevented by either phenoxybenzamine or imipramine.

Rogers, Angel and Butterfield (1968) have studied the effects of catechol (60mg/kg, I. P.) following its penetration into the mouse brain upon cerebral monoamine levels. They showed that catechol elicited convulsions consisting of jerks and tremors within 15-20 sec, with peak convulsive activity occurring after 2-3min and a duration of 8 min. They were unable to determine any changes in brain levels of either dopamine, norepinephrine, or 5-hydroxytryptamine.

A central component responsible for the circulatory stimulant actions of catechol was proposed by Gotgounis and Walton (1958) using isolated heart and papillary muscle. Walton, Walton and Thompson (1959) using mongrel dogs anesthetized with barbiturates studied the positive inotropic effects of various phenolic derivatives in situ. All drugs were administered intravenously, and DOPA (20mg/kg), catechol (100-300 mg/kg) and phenol (100-575 mg/kg) produced various degrees of positive inotropism. All benzenediols produced cerebral awakening effects and evidence of sympathetic stimulation appeared as pilomotor effects. There was an apparent dual action of the benzenediols, appearing immediately as cardiac depression followed and antagonized by a stimulant component which became greater after initial "sensitizing" doses. This "sensitizing" effect was least prominent with catechol. Phenol induced only a depressant inotropic effect,

and skeletal muscle spasms. It was noted that responses to norepinephrine were diminished after large doses of the benzenediols. Also DOPA produced no skeletal muscle effects, but cerebral awakening effects were noted; dopamine, 25 μ g/kg, exhibited marked inotropic and depressor potency.

As early as in 1896 Muhlmann reported that catechol caused an increase in blood pressure when injected into the anesthetized rabbit. Dakin (1905) injected 10mg of catechol into a 2.2 kg rabbit and produced a great increase in blood pressure. He suggested that the two free hydroxy groups in the nucleus are essential constituents of active substances, since of the three isomerid dihydroxybenzenes tested only catechol produced a rise in the blood pressure after injection; he also felt that the hydroxy groups must be in the ortho- position in relation to one another. Barger and Dale (1910) concluded that catechol raised blood pressure through a peripheral action rather than via the vasomotor center since they used decapitated cats. They also suggested that the mechanism consisted not of a sympathomimetic action but depended on a direct action on the smooth muscle. Harold, Nierenstein and Roaf (1911) showed that phenol, in small doses caused a slight rise in blood pressure accompanied with muscular tremors which they thought were induced as a direct action of the drug since the animals were curarized and decapitated. In the same study, catechol caused a marked vasoconstriction at dose of 0.01Gm, with a smaller effect at 0.03Gm,

while at 0.3Gm a sudden permanent stoppage of the heart was observed. Also noted were a darkening of the blood with each injection accompanied by muscular twitching as the heart beat became irregular and missed beats occasionally. Tainter (1930) using cats concluded that results with catechol regarding pressor and pulse rate effects showed no correlation between dose and type of circulatory response. He did observe that injections of catechol were uniformly accompanied by increases in the activity of skeletal muscles and most commonly by severe tremors and convulsions. He attempted to control these side effects by giving curare to the point at which the diaphragm was 100% paralyzed. His results indicated that catechol was causing convulsions which were partly of central and partly of muscle origin. He also agreed with Barger and Dale (1910) that catechol had direct and apparently general muscular stimulating action on smooth muscle organs. When pretreating the cats with cocaine, he saw variable effects with catechol, altogether some sympathetic stimulation was generally present. After ergotamine, he did observe some reversal of stimulation in the majority of cases. In analyzing catechol's effects upon the heart he always saw depression and cardiac dilation. A report by Mulinos and Osborne (1935a) compared the effects of catechol and epinephrine on blood pressure in anesthetized cats. Catechol and epinephrine produced similar effects causing an elevation of blood pressure when the cord was intact, in a pithed cat, or after pretreatment with cocaine. The only instance of a difference

between epinephrine and catechol was noted after pretreatment with ergotamine. In this case, there was a reversal of the epinephrine effect, i. e. vasodilation, whereas catechol still induced some vasoconstriction.

The same workers (Mulinos and Osborne, 1935b) compared the effects of catechol, epinephrine and ephedrine on the uterus of the cat. In the virgin preparation the three compounds behaved similarly, differing only in the degree of relaxation. These results were opposed to those of Barger and Dale (1910) who stated that catechol did cause a contraction of the isolated virgin uterus; a point they used to substantiate a direct muscle stimulating action for this compound. In the hands of Mulinos and Osborne epinephrine only caused a contraction of the pregnant cat uterus while catechol and ephedrine caused relaxation. These same effects were also demonstrated using the pregnant rabbit uterus. These authors then investigated the small intestine of either the cat, rabbit, or monkey showing that catechol acted as did epinephrine to cause relaxation and a contraction. Catechol differed from both epinephrine and ephedrine in not causing a dilatation of the pupil in either the cat or rabbit. This absence of pupillary action was also reported by Barger and Dale in their 1910 paper. Furthermore, Mulinos and Osborne (1935b) examined the ergotamine-catechol interplay and showed that none of the effects of catechol could be reversed after pretreatment with this alkaloid.

The earliest report on the effects of catechol on the blood sugar is that of Dubin, Corbett, and Freedman (1925) who injected 1mg/kg into a rabbit and concluded that it was ineffective in reducing blood sugar levels. At a dose of 150 mg/kg the rabbit initially went into tremors as seen in phenol poisoning and after 35 minutes died with a massive cardiac hemorrhage. Ten years later, Mulinos and Osborne (1935a) reported that, like epinephrine and ephedrine, catechol in the rabbit raised blood sugar levels.

Sjostrand (1960, 1961) reported the effects of catechol on the guinea pig ileum. Generally, he saw a stimulation with a dosage range of 0.5-5mg, as well as tachyphylaxis. He compared the stimulatory effect of 2mg of catechol with 2 units of substance P and 0.005 μ g of ACh. The contractions induced by either ACh or catechol were equally abolished by atropine (1:2 million). In higher doses, 5-10 mg, catechol had a depressant action and blocked contractions induced by ACh, histamine or substance P. From these results the author concluded that catechol stimulated the intestine through liberation of ACh and that this liberation was mediated by ganglia in the walls of the intestine. Furthermore, cocaine (10-50 μ g/ml) inhibited the contraction due to catechol as well as to nicotine (5-20 μ g) and serotonin (0.05-5 μ g), while the effects of histamine, acetylcholine, or substance P remained unaltered or augmented (Sjostrand, 1961). Hexamethonium blocked the effects of catechol and of nicotine. In sub-effective

doses, 10-50 μ g, catechol reduced the inhibitory action of epinephrine or norepinephrine (1-5 μ g) upon contractions caused by ACh, histamine, or substance P. When catechol was added to the bath together with either epinephrine or norepinephrine an increase in the basal tone of the intestinal strip was sometimes seen. On the other hand, Johnson (1962) was unable to stimulate the guinea pig ileum in doses of 0.1-5.0 mg. At a dose of 5×10^{-4} M, catechol acted as a spasmolytic; it reduced the contractures caused by 5-hydroxytryptamine and dimethylpyrophosphate. He compared this latter action to the non-specific spasmolytic effect of papaverine. In the most recent study, Takagi and Takayanagi (1965) concluded that in the case of the guinea pig ileum, phenol caused a decrease in the release of ACh whereas in that of the frog rectus abdominis muscle the same concentration caused an increased release of ACh. They suggested that there were therefore two possible mechanisms for release of ACh; one at the smooth muscle effector site and the other at the skeletal muscle.

The facilitatory action of catechol on skeletal muscle was first described by Rothberger (1905); he administered catechol to a curarized cat. In his series of experiments he also examined such compounds as nicotine, guanidine, veratrine, cresol, pyrogallol, and tetraethylammonium, noting that all had some degree of anti-curare activity. No other in vivo studies aimed at determining the mechanism of action of catechol on skeletal muscle

have been reported since these early investigations and the incomplete observations of Tainter (1930) and Barger and Dale (1910). There have been a few studies concerned with catechol's action on skeletal muscle in vitro. Mizuno (1933) and Coppee (1943) used isolated non-mammalian tissue (the frog sartorius).

Mogey and Young (1949) were the first to report on the action of catechol and phenol in isolated mammalian tissue, the rat diaphragm. The main conclusions of these authors were that phenolic substances (phenol, catechol, etc.) do not produce their anti-curare effect by cholinesterase inhibition or alteration of pH. They further suggested that this antagonism is not due to a chemical combination of antagonist with agonist; the mechanism was not elucidated further. Hobbiger (1952) agreed that phenolic substances do not act by cholinesterase inhibition when he demonstrated their action on the rat diaphragm after the inhibition of its cholinesterase activity with diisopropylfluorophosphate (DFP). Otsuka and Nonomura (1962) using the frog sartorius muscle attempted to clarify whether phenolic substances' facilitatory action was due to either an augmentation of the quantity of ACh released from motor nerve endings or else an increased sensitivity of the endplate to the transmitter. Their results showed that in a curarized nerve-muscle preparation phenolic substances would greatly increase the size of the intracellularly recorded epp without altering the sensitivity of the endplate to ACh. This latter conclusion

was based upon the fact that although the amplitude of the individual epps were enhanced by the compounds, no change was produced in the amplitude of potentials induced by iontophoretically applied ACh. The authors also suggested that phenolics might not change the amount of the stores available for transmitter release in the nerve terminals even though they do increase the amount of transmitter released. This suggestion was drawn from the experiments of Otsuka and Endo (1960a, b) wherein they concluded that the drug-induced depression of the response to the second of double stimuli in a calcium rich solution was probably due to the partial depletion of the store of available transmitter. The most recent report of junctional phenolic action is that of Kuba (1969) who used the slow muscle of the fish. This study is the first one in which the effects of phenolic compounds on spontaneously released transmitter, i. e. on the mepps, was evaluated; their possible effects on the passive membrane properties of the muscle were also investigated. His results showed that phenol increased the frequency of mepps without changing their amplitude, but did not alter the passive membrane properties such as input resistance or time constant. From these results Kuba noted the similarity in action of phenol to that of noradrenaline (Jenkinson et al., 1968), adrenaline (Krnjevic and Miledi, 1958), and guanidine (Otsuka and Endo, 1960), since all of them caused an increase in the release of transmitter expressed as an increased frequency of mepps.

In an effort to resolve some of the controversial results thus far reported, this dissertation will analyze the mechanism and site of action of the basic structural moieties of the sympathomimetic amines, namely, catechol and phenol at the mammalian neuromuscular junction. The data may have a bearing on the adjuvant action of sympathomimetic amines in myasthenics treated with anti-cholinesterases.

Future Investigations

Future investigations will include a similar analysis of the actions of ephedrine and ethanolamine at the neuromuscular junction. These two compounds should provide some additional information as to the nature of adrenoceptors at the neuromuscular junction.

METHODS

Both in vivo and in vitro techniques utilized mongrel cats of either sex weighing between 1.5-5.0 kg. The cats were all obtained from the same supplier and the surgical procedure began at the same time of day, about 9:30 A.M. Each cat was anesthetized with a compound mixture of α -chloralose, 60mg/kg; pentobarbital sodium, 6mg/kg; and atropine sulfate, 1.5mg/kg, administered intraperitoneally. The anesthetic mixture took about 20 - 30 minutes to produce surgical anesthesia which could last up to 24 hours; however, the cat was sacrificed by intravenous injection of air and heart puncture at the end of each experiment.

Surgical Procedures

The in vivo surgical procedure began with a tracheotomy to assist the cat in respiration and also to allow appropriate artificial respiration to be instituted after muscle relaxants were administered. One cannula was inserted into the internal carotid artery from which systemic blood pressure was monitored and a second cannula was inserted into the external jugular vein to allow systemic drug administration.

The method used for the preparation of the anterior tibialis muscle was that of Brown (1938) as modified by Blaber (1960). The muscle was first exposed by cutting through the skin on the lateral side of the lower limb from the ankle to just below the knee. The muscle could be completely exposed by cutting the transverse ligament. The origin of the muscle at its tendon was then freed by cutting it away with a piece of the bone attached. At this

time an opening was made into the popliteal space so that the sciatic nerve could be tied and severed and also a ligature be placed around the popliteal artery. This ligature would be used during close-arterial drug injection to insure that no dilution or washout of the drug has occurred. The peroneal nerve was isolated and freed for indirect stimulation. The entire hind limb was mounted using drills, one placed in the head of the femur and the other in the tibia and fibula. Having the lower limb fixed in position, the muscle was raised to expose the tibial artery lying between its belly and the bone. The distal end was ligated and separated from its accompanying sheath containing a vein and nerve. A fine polyethylene cannula was then inserted so that drug injections could be made in a retrograde fashion toward the heart, i. e. directly toward the muscle. A ligature around the tendon was now placed over a pulley system and attached to a Grass Force Displacement Transducer which was connected to a Dynograph. Proper muscle length and tension was determined by aligning the bone attached to the tendon with its original location in the piece of metatarsal. The muscle was thus situated so as to provide an isometric type of recording.

In experiments involving measurement of blood flow, the flow was measured as the venous effluent from the tibialis muscle by cannulating the femoral vein; the method was modified from Bowman and Zaimis (1958). A fourth cannulation was required in those experiments in which a constant

infusion of muscle relaxant was required. In those instances a cannula was inserted into the contra-lateral femoral vein of the leg that was being used to record muscle contractions. A constant infusion was maintained using a Sigma pump. This entire surgical procedure requires about one and one-half to two hours so that the actual experiments began around noon.

In experiments dealing with chronic denervation, the animals were anesthetized with pentobarbital sodium, 36mg/kg, I.P. While the animals were under anesthesia a small opening was made into the popliteal space so that a piece of the sciatic nerve, about 1 to 2cm long, could be removed. Terramycin topical powder (Pfizer) was then administered into the opening, the opening sutured, and more topical antibiotic applied. The animals were then cared for over a period of 14 - 17 days after which the usual surgical preparation was employed.

In experiments dealing with acute denervation, the nerve was removed as above, but the actual experiment was carried out forty-eight hours after the nerve section. At this time, the usual indirect stimulation of the preparation was attempted. In all cases, the preparation was able to be stimulated indirectly, but the degree of response varied.

The in vitro surgical procedure was much shorter than the in vivo procedure. Cats were anesthetized as before but neither a tracheotomy

nor any cannulations were required. The tenuissimus muscle is a deeper muscle of the hind limb than the tibialis. To isolate it, an incision was made beginning lateral to the knee and proceeding the entire length of the popliteal space. The lower portion of the muscle can be seen lying in the space, but the upper portion is hidden beneath the biceps femoris. The biceps can be severed using a cautery tip; caution is necessary nearing completion of this procedure so as not to damage the tenuissimus adhering to its fascia. The entire tenuissimus could be visualized and easily removed after clearing away some of its connective tissue. Care must be maintained so as not to damage its very small bifurcated nerve arising from the sciatic on which the muscle frequently appears to lie. After freeing the muscle from the biceps a suture was placed around each distal end of the muscle with a third suture tying off the nerve as close to the sciatic as possible.

The entire nerve-muscle preparation was removed from the cat and maintained in an isolated tissue bath. Once in the bath and receiving proper nutrient solutions and gases the preparation was further cleaned under a dissecting microscope by using micro-surgical tools. This entire procedure, from opening of the leg to placing the muscle in the tissue bath took about fifteen minutes.

Recording and Stimulating Procedures

All in vivo records were collected on an ink-writing Beckman Type-R Dynograph. Systemic blood pressure was monitored by means of a Statham pressure transducer. Muscle contractions were recorded employing a Grass Force Displacement Transducer. Blood flow was measured with a South Carolina Instruments Flow Meter. Intramuscular temperature was recorded via a 25G needle thermistor (Yellow Springs Instruments). The thermistor was carefully situated in the belly of the tibialis muscle to give accurate measurement with minimal muscle damage.

In vitro records were collected as oscilloscope tracings after filming with a 35mm Lehigh Valley Oscilloscope Camera. Oscilloscope sweep speeds and camera film speeds were synchronized to obtain an accurate record of the particular experiment (Fig. 3). Final measurements of filmed data were made after enlargement with a Durst enlarger.

In vivo preparations which required indirect stimulation were shocked by supramaximal, cathodic stimuli from various Grass stimulators available. Only denervated preparations required a stimulation duration of greater than 50 to 100 μ sec. In acutely denervated preparations indirect stimulation was only employed; a tenfold greater than normal voltage was required in all of these preparations. In chronically denervated preparations only direct stimulation was applied which was passed over the muscle be-

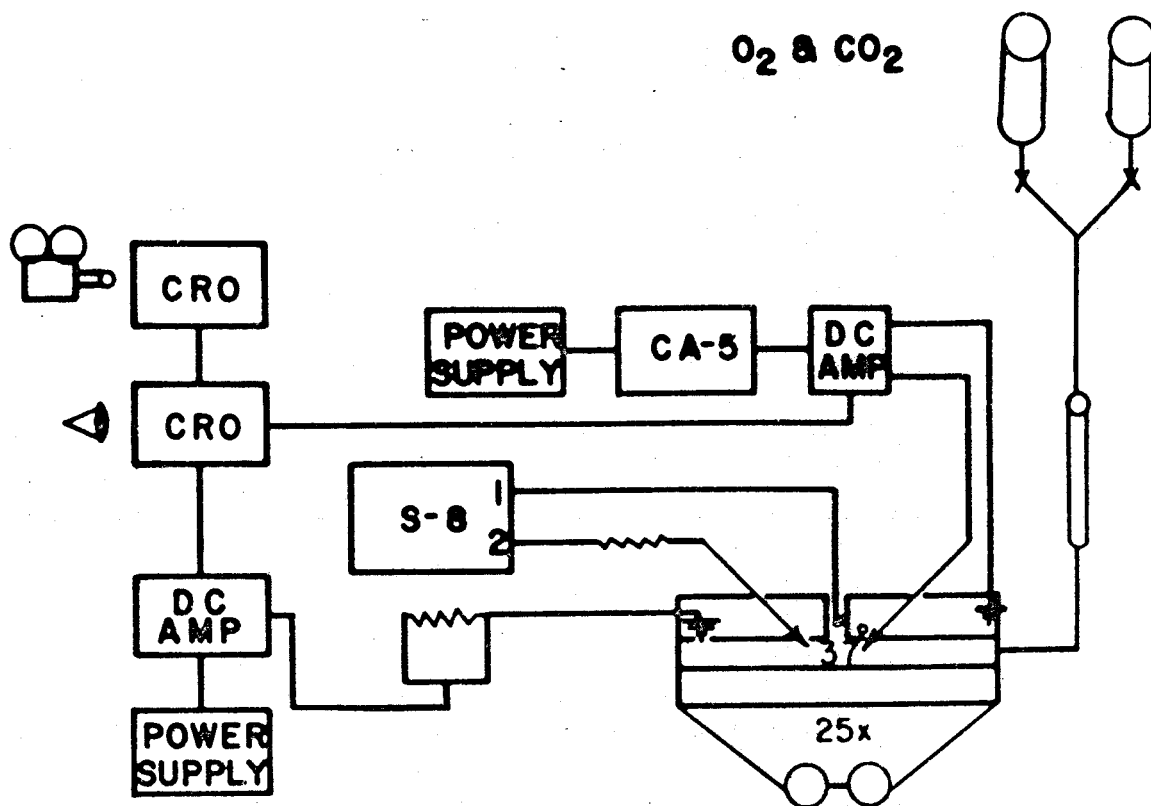

Figure 3. Diagram of the apparatus employed during *in vitro* studies. CROs are oscilloscopes for viewing and filming; CA-5 is a signal calibration device; S-8 is a two independent output stimulator; 25x is a binocular dissecting microscope; the bath temperature is maintained at 37°C.

tween two platinum wires, one inserted in the belly of the muscle and the other wound up around the tendon. Compared to indirect, direct stimulation required a longer duration, about 0.5msec and a greater voltage, 90 to 100 volts. By direct observation the denervated muscle was decreased in size and did not have the usual pink appearance of the normal muscle. The preparation was tested as to its denervation by trying to stimulate the nerve and record a muscle contraction. In all of the cases this did not occur.

The main nerve to the isolated tenuissimus muscle was stimulated via two bipolar platinum electrodes housed in a chamber adjacent to the main tissue bath. The tissue bath (nerve and muscle chambers) was made of plexiglass material.

The dimensions of the actual muscle chamber were 70mm x 10mm with a maintained fluid level of 4mm, producing a solution volume calculated to be 2800mm^3 or 2.8cm^3 . The bath was an overflow type, i. e. a dam was situated opposite the inflow and near the outflow maintaining the constant fluid level. The inflow to the bath was via an 18G needle attached to an I. D. 0.045" polyethylene tubing. This tubing coursed through a 100ml heated condensing column which was fed by a nutrient Ringer solution maintained 65 cm above the muscle bath in 500ml leveling bulbs. A constant temperature of $37^\circ\text{C} \pm 0.1^\circ\text{C}$ was maintained across the area in which the nerve and muscle was situated by preheating the perfusion solution using a constant

temperature Haake pump. The flow was adjusted between the leveling bulbs and condensing column by means of a screw clamp and maintained at an average rate of 500ml/hr. This rate of necessity varied, but was always adjusted to maintain this average flow rate.

The floor of the muscle chamber had balsa wood at its edges to which the uncut muscle was pinned over a plexiglass center for transillumination of the muscle from below and viewing of the endplate area from above. In the case of cut fiber preparations the muscle was pinned on each side of the central plexiglass base. After cutting the portions of muscle lying on the outer edges of these pins a section of tissue remained which was 9mm long (the length of the plexiglass); if cut properly, it did not contract upon indirect evoked stimulation. Whenever a muscle fiber continued to twitch following stimulation a fine scalpel was used to crush or cut the muscle closer to any visible nerve terminals; care was exercised so as not to damage any of the fine nerve endings.

Intracellular recording was accomplished with glass capillary tubing pulled to a fine tip using a Kopf Fast Co. vertical micropipette puller. The electrodes were filled under vacuum with ethyl alcohol which was displaced first by distilled water and finally by 3M KCl. The resistance of each electrode was tested prior to an experiment and the electrode

considered satisfactory if its resistance was greater than 4 megohms. Resistances of up to 30 megohms could be employed if they did not produce excessive signal noise. A fine Ag-AgCl coated silver wire was placed within the electrodes and connected to a d. c. amplifier. A Bioelectric Instrument NF-1, d. c. amplifier was employed and potentials were further amplified and viewed through a Tektronix 502-A dual beam oscilloscope. A calibration signal was also amplified by inserting a Bioelectric Calibrator CA-5 into the circuit (Fig. 3). Potentials were recorded with respect to another Ag-AgCl coated silver ground wire immersed in the bathing solution.

In experiments utilizing two intracellular electrodes, one for recording and the second to pass current, a modification of the previously described apparatus was employed. In addition to the recording apparatus and circuit as seen on the right of Fig. 3, a second electrode, stimulator and recording system was added as seen on the lower left of Fig. 3. This second electrode, made as before, was used to pass current through the cell in which it and the recording electrode was impaled. The current was amplified by means of a Nihon Hi-Input Impedance d. c. amplifier, Model-M2-3A and displayed on the lower beam of a Tektronix 502 oscilloscope. The upper beam of the oscilloscope displayed the electrotonic potential induced by this current electrode, via the recording electrode. The circuit used for this procedure was a modification of that employed by

Fatt and Katz (1951). In place of their 0.5 μF capacitor a 500 M resistor was used so as to produce a more rectangular current pulse. Current pulses had a duration of 600 to 800 msec in the midst of which an evoked epp could be imposed. With this recording technique one could obtain the extrapolated equilibrium potential and input resistance of a particular cell. Grounded aluminum foil was positioned between the two electrodes to minimize interference signals.

After the surgery was completed and recording and stimulating apparatus attached to the in vivo preparation supramaximal cathodic stimuli of 0.1/sec frequency were begun. A 15 to 30 minute interval was allowed to lapse before any drugs were administered. This interval was established so that the preparation could equilibrate at the constant intramuscular temperature of 37°C which was maintained by various heat lamps.

Drugs were injected either close-arterially or intravenously. The volume of close-arterial injections was 0.2ml. Intravenous injections were carried out in larger volumes, the largest being 5 ml. No strict time regimen was maintained although a minimal interval was allotted for the drug to be washed through the system and the preparation return to control.

In experiments during which responses to close-arterial injections of ACh were recorded the stimulator was turned off prior to, during and after the injection, altogether for a period of about 40 sec (Fig. 9).

After mounting the tenuissimus muscle in the isolated tissue bath and cleaning away the remaining connective tissue adhering to the preparation, superficial nerves could be visualized with the aid of a Zeiss binocular dissecting scope (15-100x). Microelectrodes were mounted to a Narishige micro-manipulator and the endplate region was located by varying the position of the microelectrode until the site was found where mepps and epps had the shortest rise-time and the greatest amplitude.

Miniature endplate potentials (mepps) were recorded after a control period of fifteen minutes. This period of time was maintained to allow the cell, once it had been impaled with an electrode, to equilibrate at resting potentials of -70mV or greater. Only cells which displayed mepps with a rise-time of less than 1msec were satisfactory. In the study of frequency and amplitude distribution thirty oscilloscope sweeps, each of 1 sec duration were collected. The oscilloscope was set at a horizontal time base of 0.1sec/cm , the vertical time base was set as a spot, and suitable camera speed employed to produce on the film at least thirty, one second sweeps of data with a convenient interval. The resultant recording allowed frequency to be determined either as an event per second or else a total number of events per fixed period of time, eg. 30sec . The recording could also be used to measure the amplitudes of the mepps since a calibration pulse was distributed intermittently amongst the latter. Thus, from these sweeps

a distribution histogram of control and treated preparations was constructed. Paired statistics were determined from a series of experiments in which a Latin Square design was invoked to determine the optimal concentration of the drug. The design was such that four log differential doses of catechol were compared each in the same animal as well as in other animals. A control record was taken after fifteen minutes, the drug administered and records taken for fifteen minutes; this was then followed by thirty minutes of recording following the washout of the drug. This cycle was repeated for subsequent drug administration. In early experiments recordings were taken after five minutes of the drug action at minute intervals with a plateau of effect seen between five and ten minutes. For this reason, a fifteen minute cycle was strictly maintained in all subsequent in vitro experiments. After determining the optimal dose from these results on mepp frequency, this dose was used throughout the research problem.

Effects of catechol upon rise-time, half-fall, amplitude, and resting potential of mepps were determined in another series of experiments in which essentially the same experimental design was used as that described; however, the oscilloscope horizontal time base was altered to 0.2msec/cm and the vertical sweep was adjusted as needed. A calibration pulse of 1msec duration and 0.5mV in amplitude was inserted to quantify the individual potentials. Single frame pictures were taken after fifteen minutes of at least fifteen control sweeps, the drug administered for fifteen minutes

and single frame pictures taken of at least fifteen treated sweeps. These were pooled and a paired statistic was calculated from the data obtained with seven different animals.

A drug effect upon endplate potentials (epps) was studied by blocking the muscle in two ways. Since the in vivo studies showed that catechol and phenol antagonized the d-tubocurarine block, initial studies of epps were instituted in the d-Tc blocked muscle. Epps evoked at a rate of 0.1 or 0.5/sec were collected under both control and experimental conditions, i. e. following d-tubocurarine, $2.9-5.7 \times 10^{-6} M$, or d-tubocurarine, $2.9-5.7 \times 10^{-6} M$ + catechol $1 \times 10^{-5} M$. These epps were measured as to amplitude, rise-time, half-fall and resting potential. The protocol followed a similar sequence to that employed in the mepp studies. A control record was taken after fifteen minutes, the drug administered and records taken after fifteen minutes. A calibration signal was inserted before each evoked signal to quantify accurately the results.

The second method utilized to block the muscle was that of the cut fiber technique of Barstad and Lilleheil (1968). This method has been adapted for use in the tenuissimus muscle by Blaber (1970). Cut fiber epps were collected as described for "curarized" epps and the same parameters measured. In analyzing a drug effect upon epp amplitude, rise-time, half-fall and resting potential a paired single-tailed Student's "t" test was used on the pooled data.

Trains of epps were recorded to analyze the drug effects in both the curarized muscle and the cut fiber preparation (Elmqvist and Quastel, 1965). In the case of the curarized muscle, a tetanus of 50/sec, once every minute, for one second was induced. The resultant train of epps was divided into two main sections. The first fifteen epps were classified as the 'head' of the train; they depict an initial depletion of transmitter. The remaining epps of the train, the 'tail', constitute an equilibrium state of transmitter release due to a mobilization from a pool wherein the transmitter is stored. Each epp was measured to the nearest mm after 2-3x enlargement using a Durst enlarger.

This same technique was used in the case of cut fiber preparations with the following modifications. Instead of a tetanus frequency of 50/sec a frequency of 200/sec was required to establish a run-off suitable for the plot of a regression line (Blaber, 1970). Using a train duration of 0.5sec, 100 epps could be recorded. The program was instructed in this instance to use as before the first 15 epps as the 'head' but now divided the remaining eighty-five potentials into eight groups of ten-omitting the last five of the 'tail' - for computing the variance.

These data along with the resting potential and assumed equilibrium potential of -15mV were key punched into a program written for CDC 6400 computer.

Calculations

The computer program employed Martin's (1955) correction for each endplate potential:

$$\frac{EPP}{(RP-15) - EPP} \times (RP-15).$$

The program then divided the 'tail' portion of the train into appropriate groups of five or ten epps, computed the variance of each group, and estimated the quantum size from the variance. These determinations are derived from the nature of the quantal release which follows the Poisson Distribution. If the quantal contents of individual synaptic potentials in a series are distributed according to the Poisson equation, then the coefficient of variation (C. V.) of the quantal content distribution should be equal to $1/ M$ (Edwards and Ikeda, 1962). Using this property the following relationship may be derived after

Edwards and Ikeda (1962):
Eq. 1.

$$C. V. = \frac{1}{\text{Quantal Content}}$$

OR

$$\text{Quantal Content} = \frac{1}{C. V.^2}$$

Moreover, the following relationship may be derived after

del Castillo and Katz (1954):
Eq. 2.

$$\text{Quantal Content} = \frac{epp}{mepp} \quad \text{OR} \quad mepp = \frac{epp}{\text{Quantal Content}}$$

Combining Eq. 1. and Eq. 2. one may obtain:

Eq. 3.

$$mepp = \frac{epp}{1/C.V.^2}$$

Following Goldstein (1969) Eq. 4. may be derived:

$$C.V. = \frac{S.D.}{mean} \quad \text{AND} \quad \text{Variance} = S.D.^2$$

Eq. 4.

$$C.V.^2 = \frac{\text{Variance}}{mean^2}$$

Combining Eq. 3. and Eq. 4. for a series of epps one obtains the following set of equations (Eq. 5. and Eq. 6.):

Eq. 5.

$$mepp = (epp) \frac{\text{Variance}}{(epp)^2}$$

Eq. 6.

$$mepp = \frac{\text{Variance}}{epp} (q)$$

The mean estimate of the quantum size (q) was used to calculate the quantal content of each epp and the mean quantal content of the epps comprising the 'tail'. Mobilization rate (dm) was estimated as the mean quantal content of the 'tail' divided by its stimulus interval. The stimulus interval is the time in msec between pulses in a tetanus. This interval varied depending on the preparation. The stimulus interval in d-tubocurarine blocked preparations was 20 msec since the frequency of the tetanus was 50/sec. The stimulus interval in cut fiber preparations was 5 msec since these preparations were tetanized at 200/sec. From the quantal content

of each of the first 15 epps and the cumulative quantal release, the program calculated a series of correlation coefficients which described the linearity of a regression line resulting from the early decline of quantal content. Arbitrarily, the fifth point was chosen as the point which began to deviate from a linear relationship. Blaber (1970) had in fact determined that the sixth epp of each train stimulated at 200/sec was the last point to remain on this regression line.

The program calculated the extrapolated point on the 'y' axis which was equivalent to the quantal content of the first endplate potential (M_0); the program calculated also the extrapolated intercept on the 'x' axis which constituted the size of the available store of quanta (n). The fraction of the store released by the first impulse probability of release (p) was calculated by dividing the quantal content of the first endplate potential by the readily releaseable store (M_0/n). Elmqvist and Quastel (1965) have pointed out that when this method is applied in a situation where the probability of release is variable, the estimate of 'q' derived from its variance will be smaller, but not necessarily less than the actual value for quantum size.

In the determination of M_0 , n , p , q , and dm a paired statistical analysis was performed. The control for each animal was taken at a time

fifteen minutes after impalement of the cell. The drug was then perfused and a record was taken fifteen minutes later. In most experiments more than one set of controls and experimental results were recorded in order to insure filming the data. In instances when more than one record was available control and experimental data were averaged.

Calculations involving the determination of equilibrium potential and membrane resistance were as follows. Plots of applied current vs. membrane potential change were drawn by fitting the best line through the experimental results and the x-y intercept. Input resistance was calculated by dividing the value of the current applied to the preparation into the resultant amplitude of the electrotonic potential. Both the current and electrotonic potential could be measured directly from the oscilloscope recordings. Using the method of least squares a line was plotted through the experimental points obtained from the change in membrane potential vs. the change in epp amplitude. This line extrapolated to the x-intercept was the equilibrium potential for the given cell. This protocol was employed in cut fiber preparations before and after the addition of catechol.

Solutions and Drugs

All the drugs used in the study were dissolved in normal saline solution and diluted as required. There are two exceptions to this statement: 1)

Acetylcholine HCl manufactured by City Chemical Corporation was dissolved in distilled water and maintained at a pH of less than 4.0 by the addition of HCl. The resultant solution was stable if kept under refrigeration.

2) Phenoxybenzamine HCl, supplied by Smith, Kline and French Laboratories, had to be solubilized for intravenous injection by the method described in Martindale's Pharmacopia, pp. 1441-2. The remaining drugs and their suppliers were: d-Tubocurarine, Abbott Laboratories; d, l-Propranolol, Imperial Drug Co., Ltd.; Neostigmine Dr, City Chemical Corporation; l-Epinephrine HCl, Winthrop Laboratories; Dopamine HCl, Sigma Chemical Corporation; Phenol-crystals, J.T. Baker Chemical Co.; Aminophylline, G.D. Searle and Co.; Benzoquinonium HCl, Sterling-Winthrop Labs. and Catechol, Eastman Organic Chemicals.

The irrigating solution for the in vitro preparation was described by Krebs and Henseleit (1932) and consisted of the following components;

NaCl	115mM
KCl	4.60mM
KH ₂ PO ₄	1.15mM
NaHCO ₃	24.1mM
CaCl ₂	2.46mM
MgSO ₄	1.15mM
d-Glucose	8.85mM

This solution was bubbled with 95% oxygen and 5% carbon dioxide. In preparations that required the addition of d-tubocurarine to permit recording of epps or their trains the drug was added in a dose of $2.9-5.7 \times 10^{-6}$ M.

CATECHOL**PHENOL****DOPAMINE****EPINEPHRINE**

Figure 4. Chemical structures of some of the compounds investigated in this dissertation.

RESULTS

Antagonism of d-tubocurarine blockade:

In twenty-two experiments, d-tubocurarine (d-Tc) was given intravenously either in single injection (500 μ g) or in slow perfusion (1.2-1.8mg/hr) to produce in all cases approximately 80% blockade of the muscle. Various doses of catechol or phenol were effective in antagonizing d-Tc, the optimal dose being 50 μ g and 250 μ g respectively (Fig. 5 and 6). The effects of catechol and phenol were then compared to epinephrine (5 μ g) or dopamine (1mg) in ten other experiments. Epinephrine produced a depression after an initial antagonism. This secondary depression by epinephrine had been first reported by Naess and Sirnes (1953). Dopamine, on the other hand, only produced a depression (Fig. 7) after d-Tc.

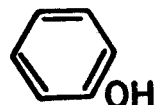
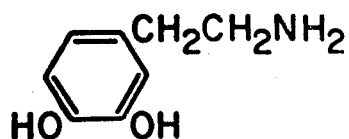
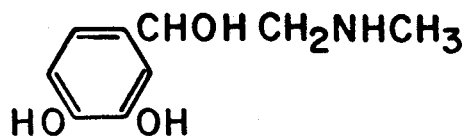
In twelve cats, catechol and phenol were administered in the presence of the alpha-adrenoreceptor blocking drug, phenoxybenzamine (5mg/kg, i. v.); in ten cats the beta-adrenoreceptor blocking drug, propranolol (2mg/kg, i. v.) was given prior to catechol or to phenol. The antagonism by catechol or phenol was unchanged in the presence of either of the adrenoreceptor blocking drugs (Fig. 5 and 6). The initial antagonism produced by epinephrine was abolished after the alpha-blocker (Maddock, Rankin, and Youmans, 1948), but was still prominent after the beta-blocker (Bowman and Raper, 1966). The depression or "curaremimetic" action of

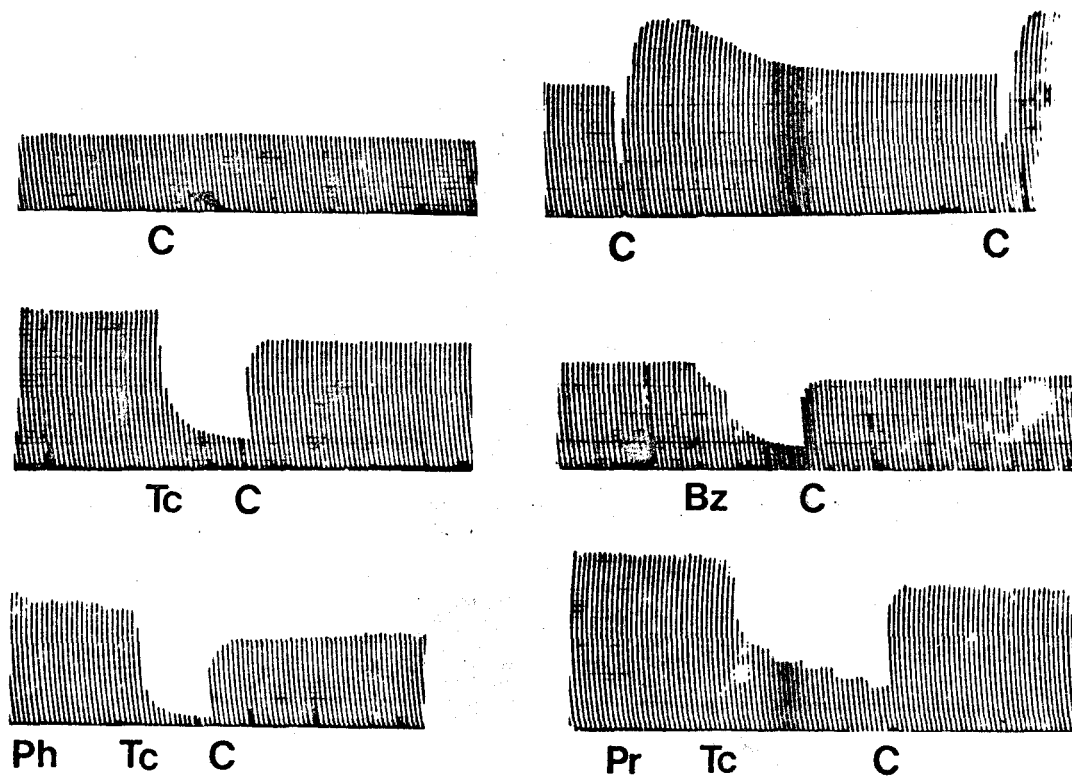

Figure 5. The effects of catechol in innervated cat anterior tibialis muscle. At C, catechol was injected close-arterially in the dose of 50 μ g, except in the upper right hand panel where the dose was 20mg. At Tc, d-tubocurarine (0.5mg, i.v.), at Bz, benzoquinonium (0.25mg, i.v.), at Ph, phenoxybenzamine (5mg/kg, i.v.), and at Pr, propranolol (2mg/kg, i.v.) were injected. Calibration = 5min x 0.5kg

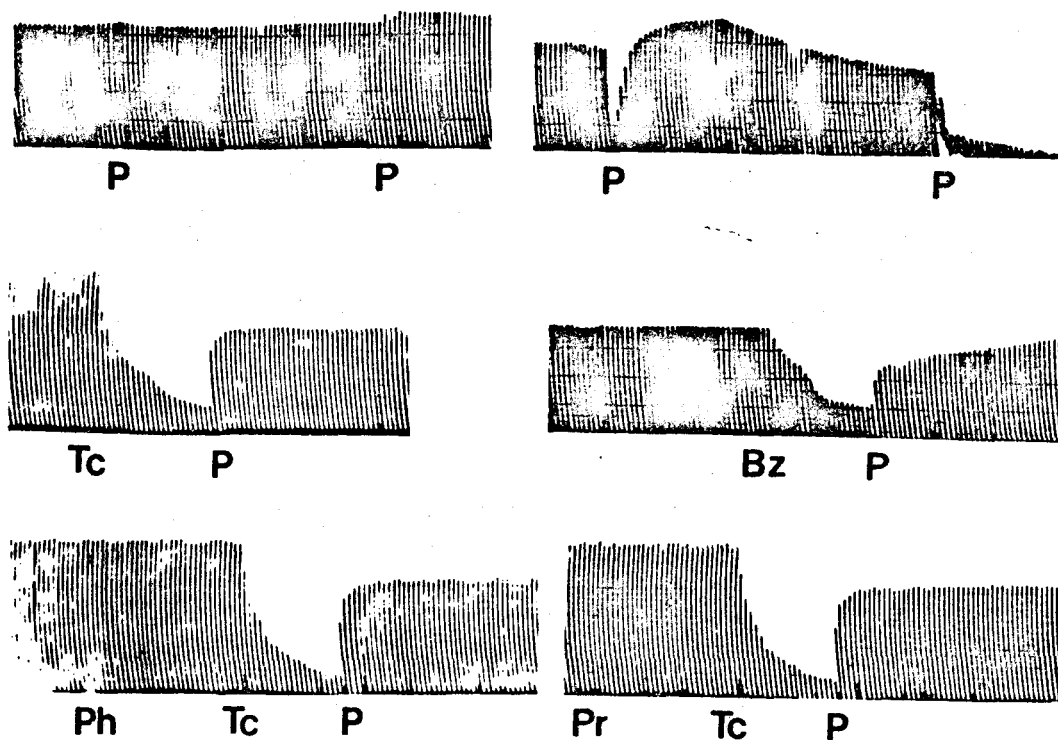

Figure 6. The effects of phenol in innervated cat anterior tibialis muscle. At P, phenol in the dose of 250 μ g was injected close-arterially, except in the case of the upper right hand panel where the dose was 10mg. At Tc, d-tubocurarine (0.5mg, i.v.), at Bz, benzoquinonium (0.25mg, i.v.), at Ph, phenoxybenzamine (5mg/kg, i.v.), and at Pr, propranolol (2mg/kg, i.v.) were injected. Calibration = 5min x 0.5kg

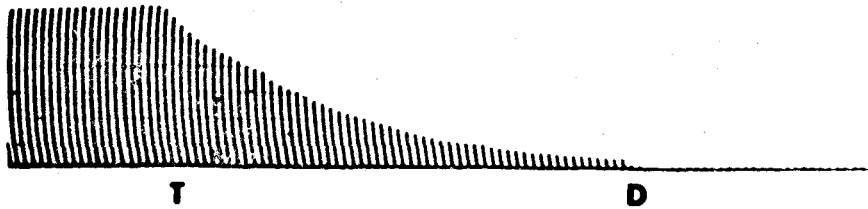
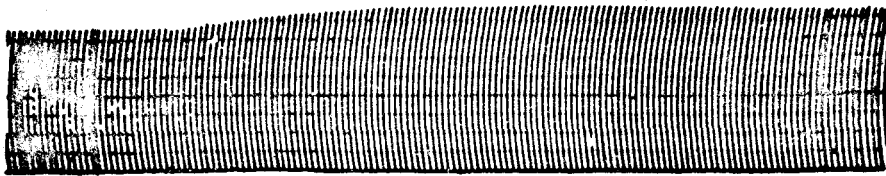

Figure 7. Effects of dopamine in innervated cat anterior tibialis muscle. At D, dopamine was injected close-arterially in the dose of 1mg. At T, d-tubocurarine (0.5mg, i.v.) was injected. Calibration = 5min x 0.5kg

dopamine could not be affected by either type of blocking agent (Ferko and Calesnick, 1971).

Antagonism of benzoquinonium blockade:

In six experiments, benzoquinonium was administered as a single injection (250 μ g), and catechol (50 μ g) or phenol (250 μ g) was given close-arterially at the peak of the block (Fig. 5 and 6). Both compounds antagonized the paralysis. Both compounds also appeared to antagonize the benzoquinonium block faster than the d-Tc block. A quicker complete antagonism, may be attributed to the presynaptic facilitatory effect of low doses of benzoquinonium (Christ and Blaber, 1968), which adds to a possible presynaptic facilitatory action of catechol. Epinephrine was also shown to antagonize benzoquinonium (Bowman, 1958).

Effect on maximal contraction:

In eight experiments, doses of catechol or phenol previously shown to antagonize d-Tc only slightly augmented the indirectly excited contraction. The average facilitation observed with catechol (50 μ g, c. a.) and phenol (250 μ g, c. a.) was 2.5% and 9%, respectively (Fig. 5 and 6). However, in higher doses, catechol (20mg) and phenol (10mg) either had a biphasic action, consisting of partial block and facilitation, or produced complete block (Fig. 5 and 6). In five experiments, the "curaremimetic"

dose of dopamine (1mg) always caused about 10% augmentation of the contraction (Fig. 7).

In five experiments, catechol (50 μ g to 10mg) or phenol (100 μ g to 10mg) had no effect on chronically denervated, directly stimulated preparations (Fig. 3). Catechol or phenol did not produce contraction when injected close-arterially in the case of either the innervated or denervated muscle. No fibrillations were recorded after their injection into denervated muscles.

Using the method of Okamoto and Riker (1969) six experiments were performed on subacutely denervated (48 hours prior to the experiment) preparations. The muscle was stimulated indirectly, and single doses of d-Tc were administered to produce an 80% block. At this level of block, either catechol (50 μ g) or phenol (250 μ g) was injected close-arterially. The d-Tc-catechol and d-Tc-phenol antagonism were either abolished or markedly reduced by the subacute denervation (Fig. 8). This procedure also appeared to reduce or eliminate the slight facilitation produced by either compound in normal preparations.

Effect on responses to close-arterially injected acetylcholine:

Figure 9 shows the effects of catechol on the response to close-arterially injected ACh during an infusion of d-Tc. In all five experiments, there was no increase in the ACh-induced contraction in the presence of

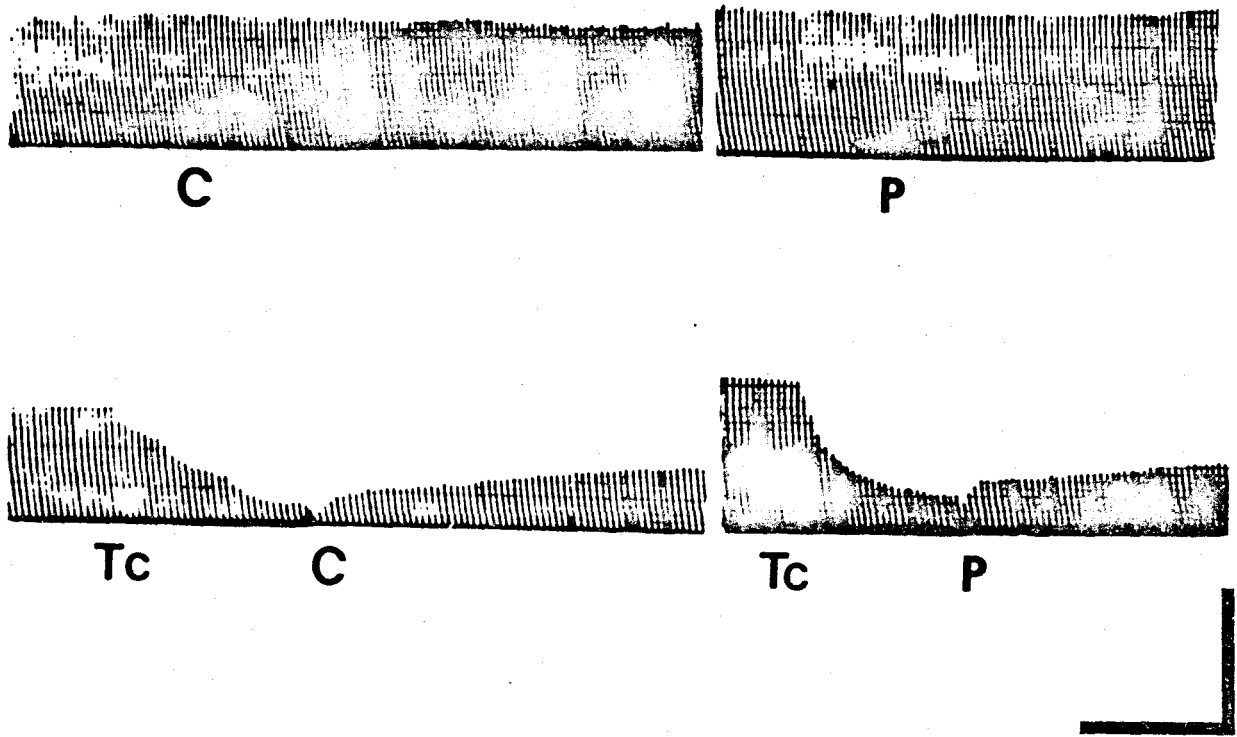

Figure 8. Effects of catechol and phenol on chronically denervated (upper panels) and subacutely denervated (lower panels) muscles. At C, catechol (50 μ g, c.a.), at P, phenol (250 μ g, c.a.), and at Tc, d-tubocurarine (0.5mg, i.v.) were injected. Calibration = 5min x 0.25kg.

catechol, but, rather, an initial depression at the peak of the d-Tc-catechol antagonism. ACh contractions returned to the control height shortly thereafter.

Effect of blood flow upon drug action:

No particular vascular effect seemed to be related to the drug responses. In five animals, catechol (50 μ g, c. a.) and phenol (250 μ g, c. a.) consistently produced a vasoconstriction; an average 25 and 44% decrease of flow was induced by catechol and by phenol, respectively. These effects were compared to those of 5 μ g and 25 μ g doses of epinephrine given c. a. and i. v. respectively. Either route of administration caused an average decrease in flow of 75%. On the other hand isoproterenol, at 50 μ g, i. v., enhanced the flow rate by 40%. Bowman and Raper (1966) comparing the three catecholamines, epinephrine, norepinephrine, and isoproterenol, concluded that the observed contractile muscle responses were independent of the accompanied vascular effects which may have been due to the administration of the drugs. An earlier report by Bowman and Zaimis (1958) demonstrated that when epinephrine and norepinephrine are administered in very high doses which caused a marked vasoconstriction, this vasoconstriction could produce a depression of both submaximal and maximal tetanic tensions. This depression could be prevented by the prior administration of adrenergic receptor blocking substances. No reports have described in full the effects of drugs upon blood flow during a d-Tc paralysis.

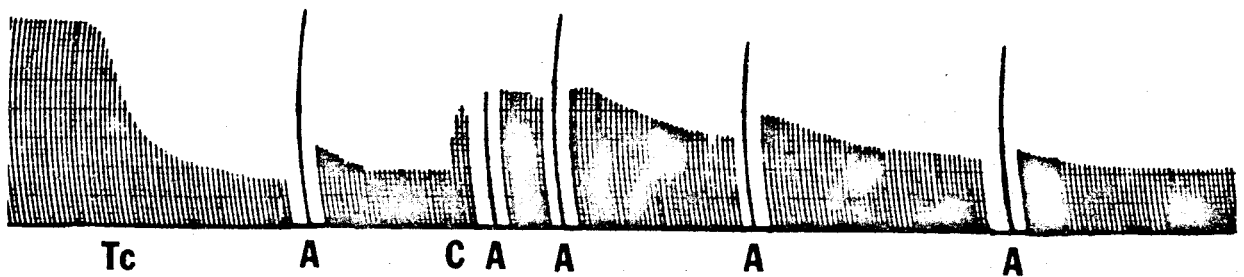

Figure 9. The effect of catechol on the response to close-arterially injected acetylcholine. At Tc, a constant infusion of d-tubocurarine (1.2mg/hr, i.v.) was started. At A, acetylcholine (80 μ g, c.a.) and at C, catechol (50 μ g, c.a.) were injected. Calibration = 5min x 0.5kg

Effect of combinations of catechol and phenol with neostigmine and aminophylline:

Breckenridge et al. (1967) concluded that a combination of epinephrine and neostigmine produces a beta-adrenergic effect on the nerve terminal, which could be augmented by the concomitant administration of aminophylline. In a series of experiments, the same procedure as that of Breckenridge et al. (1967) was employed to examine this question and the results are shown in Tables 1. and 2. Table 1. presents the average measurements of the facilitation produced by the individual drugs, catechol, phenol, neostigmine and aminophylline; Table 2. shows the average facilitation produced by the various drug combinations. Figure 10 illustrates a typical experiment. The effects of catechol, phenol, or epinephrine were augmented by neostigmine and further increased, quite markedly, by aminophylline. Neither propranolol nor phenoxybenzamine abolished the effects of the aminophylline when combined with phenol or catechol, although both produced some degree of inhibition. A mixture of epinephrine (0.2 μ g close-arterially) and neostigmine (20 μ g, i. v.) produced a 22% increase in contraction height; when aminophylline (25mg/kg, i. v.) was added to the combination, a 64% increase in contraction height was produced. In four instances, pretreatment with propranolol (2mg/kg, i. v.) reduced the augmentation of the epinephrine-neostigmine-aminophylline combination to 27%, thus confirming the results of Breckenridge et al. (1967).

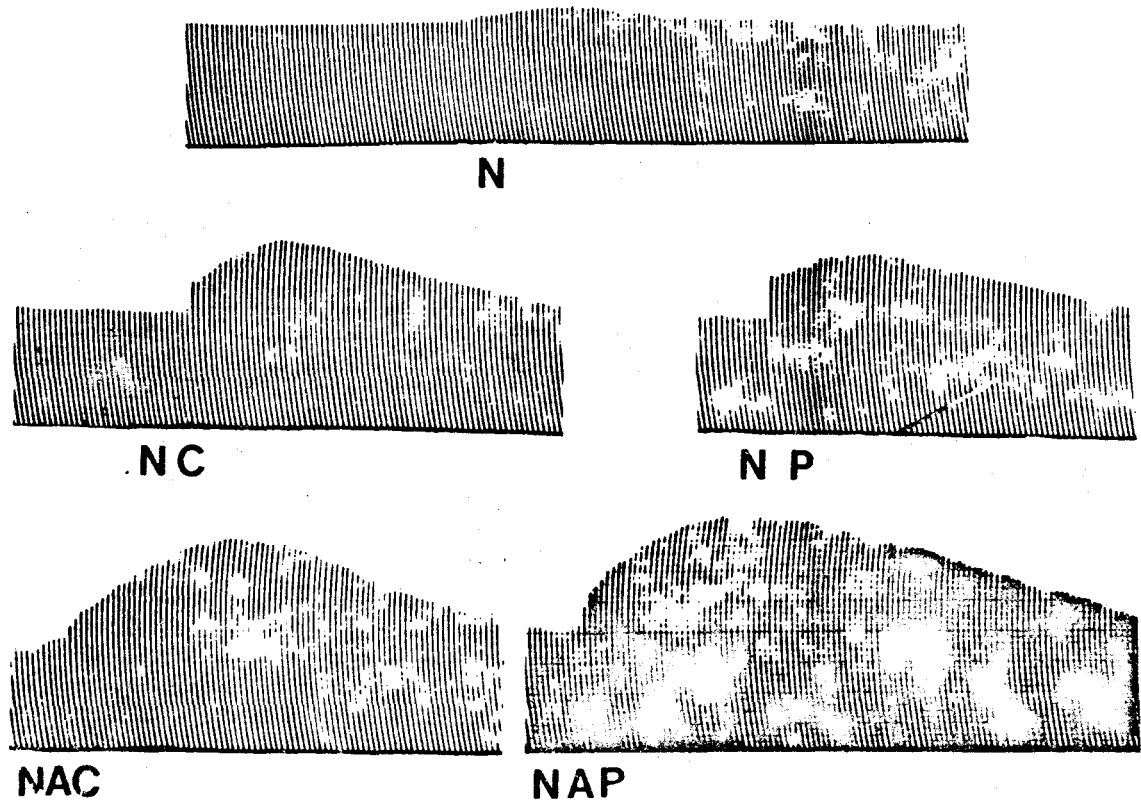

Figure 10. The effect of combinations of neostigmine and aminophylline with catechol or phenol on muscle contractions. At N, neostigmine ($20\mu\text{g}$, i.v.), at C, catechol ($50\mu\text{g}$, c.a.), at P, phenol ($250\mu\text{g}$, c.a.) and at A, aminophylline ($25\text{mg}/\text{kg}$, i.v.) were injected. Calibration = $5\text{min} \times 0.5\text{kg}$.

TABLE 1. Percentage Facilitation of Muscle Contraction

	Catechol (50µg, c.a.)	Phenol (250µg, c.a.)	Neostigmine (20µg, c.a.)	Aminophylline (25mg/kg, i.v.)
MEAN	2.5	9.0	29.3	30.0
+S.D.	+0.3	+1.7	+6.2	+11.2
N	4	4	20	3

$$\% \text{ Facilitation} = \frac{\text{Control} - \text{Treated Contraction}}{\text{Control Contraction}} \times 100$$

TABLE 2. Percentage Facilitation by Drug Combination

	Catechol (50µg,c.a.) + Neostigmine (20µg,c.a.)		Phenol (250µg,c.a.) + Neostigmine (20µg,c.a.)	
	MEAN + S.D.	N	MEAN + S.D.	N
CONTROL	49.3 + 12.5	11	47.3 + 24.0	6
+Aminophylline (25mg/kg,i.v.)	94.3 + 16.3	12	88.1 + 16.9	10
+Aminophylline (Pretreated with phenoxybenzamine 5mg/kg,i.v.)	88.0 + 19.1	3	82.5 + 6.3	4
+Aminophylline (Pretreated with propranalol 2mg/kg,i.v.)	85.6 + 26.4	6	76.5 + 25.9	6

Effect of catechol upon miniature endplate potentials (mepps):

Mepps were obtained as described in the METHODS section. Initial experiments were undertaken to determine a dose-response relationship for catechol on the isolated nerve-tenuissimus preparation. In vivo, catechol was unable to stimulate directly the postsynaptic membrane in either innervated or denervated muscle. Furthermore catechol was unable to induce sensitization or demonstrate anti-ChE activity as evidenced by the fact that it did not affect the response to c. a. injections of ACh. Thus, a possible presynaptic mechanism of action could be expected, and it was first attempted to elucidate this possibility by an examination of mepp frequency. The effects of three concentrations of catechol ($10^{-7}M$, $10^{-6}M$ and $10^{-5}M$) were analyzed (Table 3). An increase in frequency was observed with both the $10^{-6}M$ and $10^{-5}M$ doses; while frequently it was impossible to maintain the electrode within the cell in the case of a $10^{-4}M$ concentration, a decrease in frequency was noted in the successful experiments.

The results obtained in nine different cats were analyzed in terms of mepps observed over a thirty second period (cf. Methods). From these same experiments a distribution of mepp amplitudes was also obtained; no apparent change was observed at any of the concentrations studied. Histograms of the frequency distribution (N=999) and of the amplitude distribution (N=1217) were constructed from mepps observed in control and in

TABLE 3.
 EFFECTS OF CATECHOL ON MEPP FREQUENCY
 FREQUENCY OBSERVATIONS OVER THIRTY SECOND PERIOD

	<u>CONTROL-10⁻⁷M</u>	<u>CONTROL-10⁻⁶M</u>	<u>CONTROL-10⁻⁵M</u>	<u>CONTROL</u>				
CAT I	52	56	52	61	61	74	57	
CAT II	68	85	40	87	58	98	83	
CAT III	44	36	44	55	44	68	52	
CAT IV	37	58	62	87	65	89	83	
CAT V	60	56	59	61	50	66	67	
CAT VI	39	62	53					
CAT VII			65	69	60	71	57	
MEAN	50.0	58.8	53.6	70.0*	56.3	77.7*	66.5	
<u>+S.E.</u>	<u>+5.0</u>	<u>+6.4</u>	<u>+3.5</u>	<u>+5.7</u>	<u>+3.2</u>	<u>+5.3</u>	<u>+5.6</u>	

**The difference is statistically significant at $p < .0025$

* The difference is statistically significant at $p < .05$.

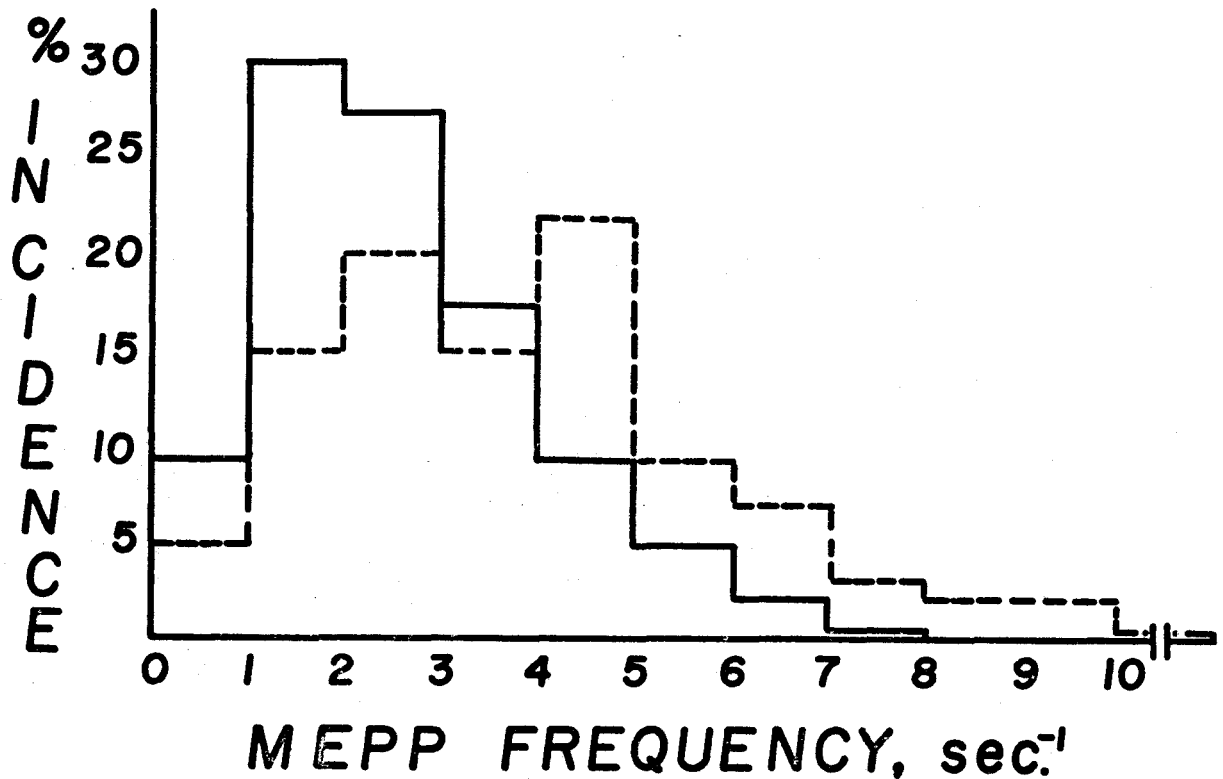

Figure 11. The frequency distribution of control mepps (solid line) and mepps in nine preparations treated with $1 \times 10^{-5} M$ catechol for fifteen minutes (dashed line). The mean values obtained for control and treated preparations were 2.2 and 3.2 mepps/sec, respectively.

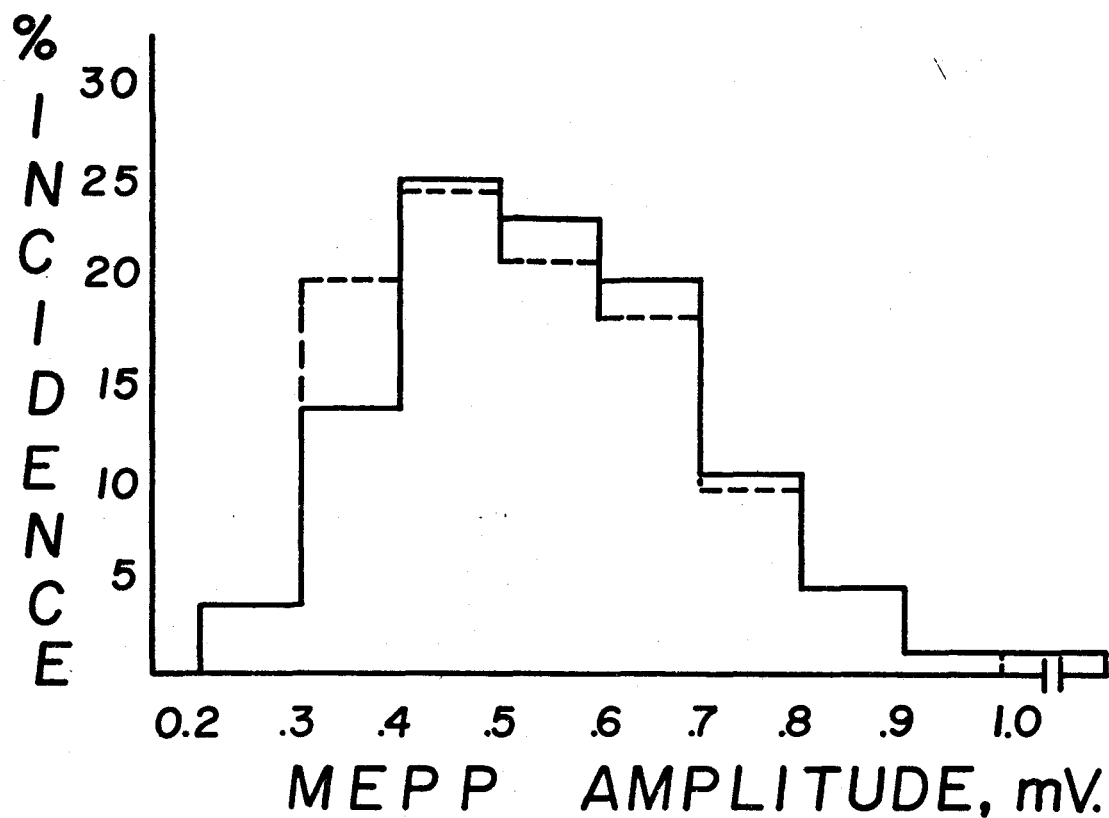

Figure 12. The amplitude distribution of mepps obtained in control (solid line) and thirteen treated preparations (dashed line). Catechol, $1 \times 10^{-5} \text{M}$ was added to the control and results collected after fifteen minutes. The mean amplitude of both control and treated preparations was equal (0.50mV).

TABLE 4.

EFFECTS OF CATECHOL, $1 \times 10^{-5}M$, ON MINIATURE E.P.P.s

	<u>Amplitude</u> (mV)	<u>Rise-time</u> (msec)	<u>Half-fall</u> (msec)	<u>R.P.</u> (mV)
CONTROL (N=7)	0.58 <u>+.03</u>	0.45 <u>+.02</u>	0.95 <u>+.03</u>	74.0 <u>+2.3</u>
TREATED (N=7)	0.60 <u>+.03</u>	0.48 <u>+.01</u>	1.01 <u>+.02</u>	74.4 <u>+2.4</u>

The differences are not statistically significant.

Data pooled from seven cats and expressed as mean + standard error.

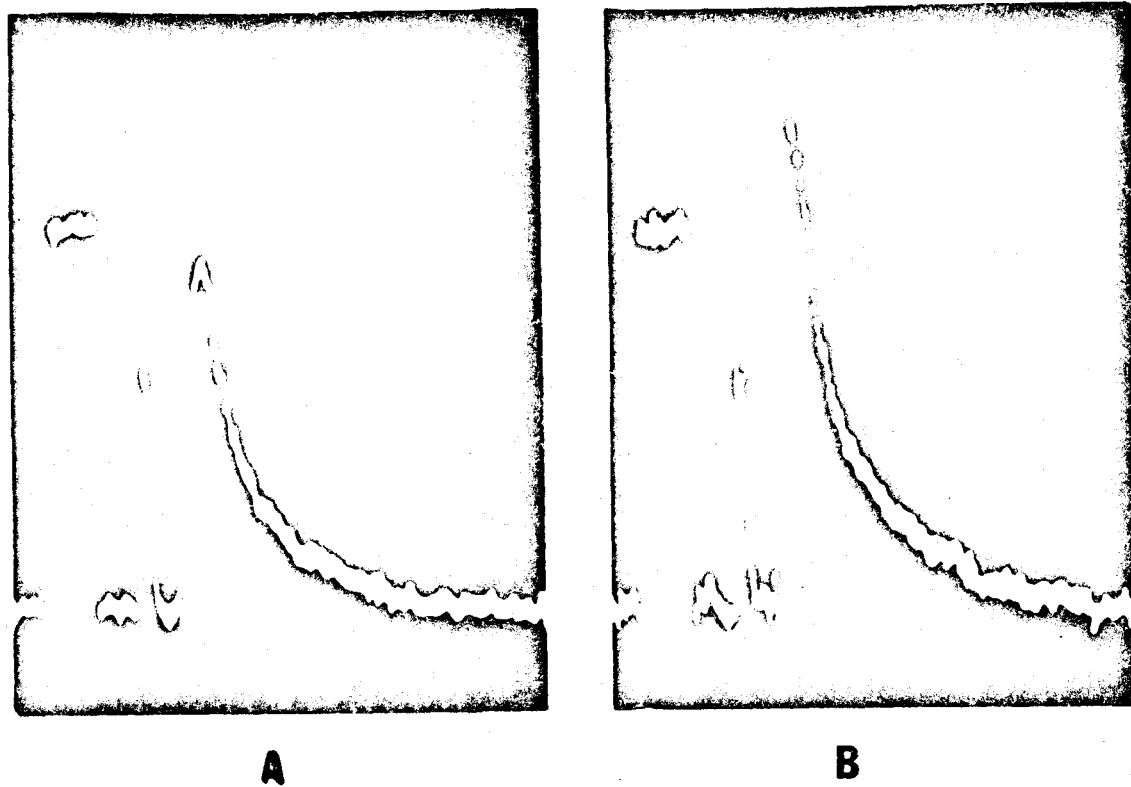

Figure 13. Epp before (panel A) and after (Panel B) $1 \times 10^{-5} \text{M}$ catechol. In both cases d-tubocurarine ($4.3 \times 10^{-6} \text{M}$) was employed. The square calibration signal is $2 \text{mV} \times 1 \text{msec}$.

TABLE 5.

EFFECTS OF CATECHOL, $1 \times 10^{-5}M$, ON E.P.P.s IN d-Tc

	Amplitude (mV)	Rise-time (msec)	Half-fall (msec)	R.P. (mV)
CONTROL (N=4)	3.35 <u>+.45</u>	0.53 <u>+.10</u>	1.43 <u>+.27</u>	76.5 <u>+3.8</u>
TREATED (N=4)	4.12* <u>+.55</u>	0.52 <u>+.07</u>	1.34 <u>+.45</u>	76.0 <u>+4.2</u>

*The difference is statistically significant at $p < .01$.

Data pooled from four cats and expressed as mean \pm standard error.

**A****B**

Figure 14. Epp before (Panel A) and after (Panel B) $1 \times 10^{-5} \text{M}$ dopamine. In both cases d-tubocurarine ($4.3 \times 10^{-6} \text{M}$) was employed. The square wave calibration signal is $2 \text{mV} \times 1 \text{msec}$.

TABLE 6.
EFFECTS OF DOPAMINE, $1 \times 10^{-5} M$, ON E.P.P.s IN d-Tc

	<u>Amplitude</u> <u>(mV)</u>	<u>Rise-time</u> <u>(msec)</u>	<u>Half-fall</u> <u>(msec)</u>	<u>R.P.</u> <u>(mV)</u>
CONTROL (N=3)	5.19 <u>+.73</u>	0.47 <u>+.04</u>	1.03 <u>+.37</u>	74.7 <u>+11.8</u>
TREATED (N=3)	4.48 <u>+1.31</u>	0.42 <u>+.07</u>	1.11 <u>+.46</u>	74.7 <u>+11.8</u>

The differences are not statistically significant.

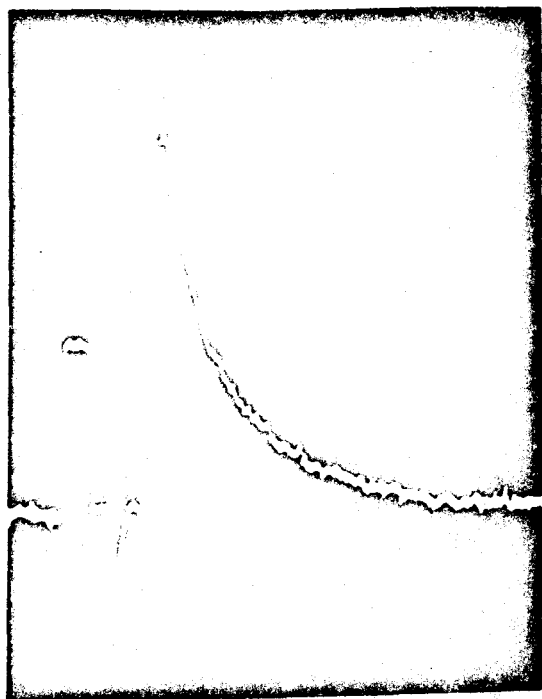
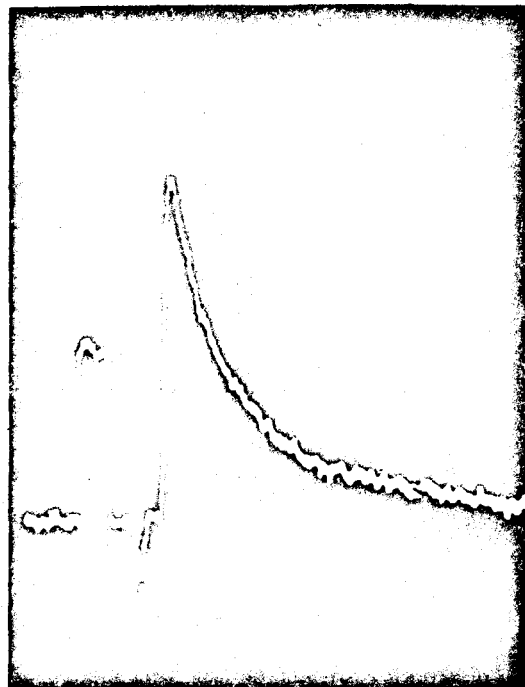
Data pooled from three cats and expressed as mean + standard error.

preparations treated with 1×10^{-5} M catechol (Fig. 11 and 12). The frequency, but not the amplitude distribution was significantly affected by this concentration of catechol, confirming the data shown in Table 3. Finally, individual mepps were analyzed in regard to a possible effect of catechol on rise-time, half-fall, amplitude, or resting membrane potential. These results are depicted in Table 4. As can be seen, there was no significant change in any of the parameters measured.

Effect of catechol and dopamine upon endplate potentials in d-Tc blocked muscles:

Figure 13 shows a typical epp in d-Tc on the left (A) and the effect of 1×10^{-5} M catechol added to d-Tc on the right (B). In two of four instances it could be seen microscopically that some muscle fibers of the preparation began to twitch after perfusion with catechol. Table 5 summarizes this effect of catechol upon epp amplitude, rise-time, half-fall and membrane potential. A statistically significant increase in the amplitude was observed in four different animals; the other parameters were not significantly affected.

The effects of dopamine (1×10^{-5} M) on a representative epp in the presence of d-Tc are demonstrated in Fig. 14. Table 6 shows that there is no statistical difference in any of the parameters measured; namely, amplitude, rise-time, half-fall or resting potential. However, following the

treatment there was a small decrease in the amplitude of the epp as well as a slight prolongation of the half-fall. This decrease in amplitude recorded in d-Tc-treated preparations parallels the "curaremimetic" action of dopamine as seen in the in vivo preparation.

Effect of catechol and dopamine upon storage and release of transmitter in d-Tc blocked muscles:

The action of a drug can be pre- or post-synaptic or both. In order to separate such actions of a drug with regard to these sites the method of Elmqvist and Quastel (1965) was employed. A train of epps in d-Tc was compared to a train of epps in the same preparation treated with catechol (1×10^{-5} M). Each train consisted of a tetanic stimulus at 50/sec. A portion of a pair of these trains of epps can be seen in Fig. 15. Not much visible change can be observed in this typical experiment. Computer analysis shows however that an effect was obtained (Table 7). This analysis demonstrates a highly significant increase in the quantal content of the first epp (M_0), as well as a highly significant decrease in quantum size (q). The large increase in M_0 can be explained by the concomitant significant increase in the probability of release (p) and mobilization (dm). The large decrease in q might be explained by the insufficient increase in the readily available stores (n); the turnover of transmitter that is demanded by the increase in q may be exhausting the available "mature" quanta and forcing "younger" quanta to be mobilized.

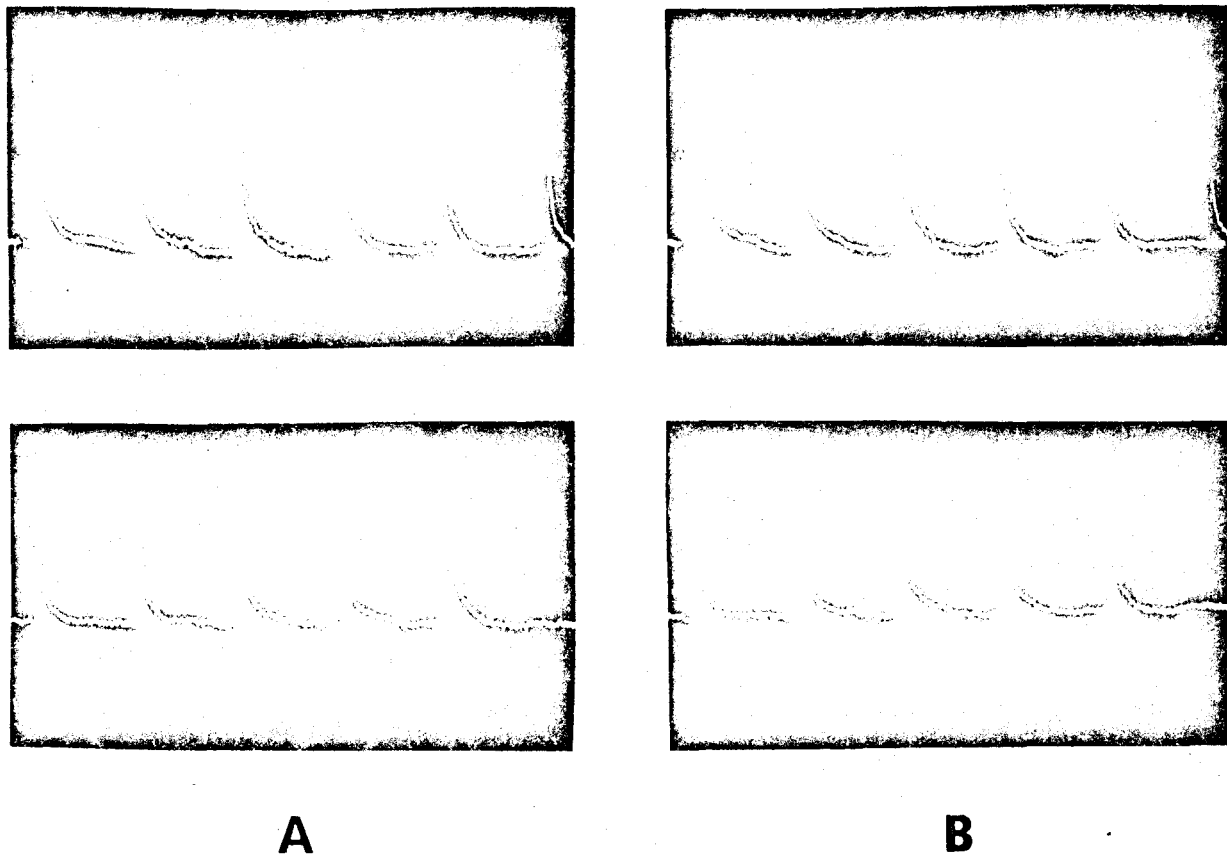

Figure 15. The first six and the last five epps of a tetanus before (Panel A, top and bottom, respectively) and after (Panel B, top and bottom, respectively) $1 \times 10^{-5} \text{M}$ catechol. Each tetanus was recorded in the presence of d-tubocurarine ($4.3 \times 10^{-5} \text{M}$). Stimulus frequency = 50/sec. Calibration signal = 5mV.

TABLE 7.

EFFECTS OF CATECHOL, $1 \times 10^{-5} M$, ON STORAGE AND RELEASE
OF TRANSMITTER IN d-Tc

	M_0 (quanta)	n (quanta)	$\frac{p}{(M_0/n)}$	q (mV)	dm (quanta/msec)
CONTROL (N=6)	230.6 <u>+41.5</u>	1330 <u>+187</u>	0.186 <u>+.028</u>	0.015 <u>+.004</u>	6.3 <u>+1.7</u>
TREATED (N=6)	526.9** <u>+122.0</u>	2067 <u>+563</u>	0.276* <u>+.048</u>	0.010** <u>+.003</u>	10.0* <u>+2.9</u>

**The differences are statistically significant at p .01

*The difference is statistically significant at p .05

Data pooled from six cats and expressed as mean + standard error.

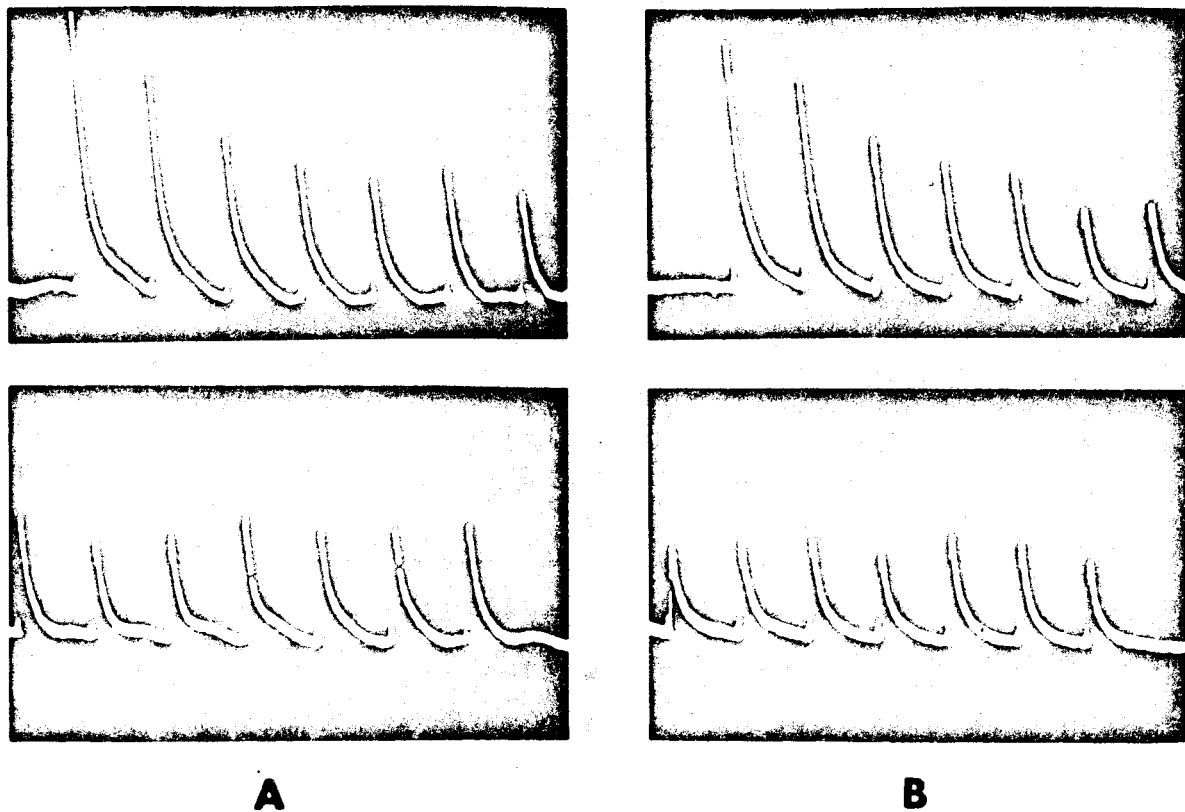

Figure 16. The first and last seven epps of a tetanus before (Panel A, top and bottom, respectively) and after (Panel B, top and bottom, respectively) $1 \times 10^{-5} \text{M}$ dopamine. Each tetanus was recorded in the presence of d-tubocurarine ($4.3 \times 10^{-6} \text{M}$). Stimulus frequency = 50/sec. Calibration signal = 5mV.

TABLE 8.
EFFECTS OF DOPAMINE, $1 \times 10^{-5}M$, ON STORAGE AND RELEASE
OF TRANSMITTER IN d-Tc

	M_0 (quanta)	n (quanta)	p (M_0/n)	q (mV)	dm (quanta/msec)
CONTROL (N=3)	264.0 <u>+69.7</u>	1399 <u>+230</u>	0.187 <u>+0.042</u>	0.014 <u>+0.007</u>	4.75 <u>+1.07</u>
TREAT (N=3)	364.1 <u>+115.0</u>	2015 <u>+470</u>	0.184 <u>+0.044</u>	0.011 <u>+0.001</u>	6.80 <u>+2.00</u>

The differences are not statistically significant.

Data pooled from three cats and expressed as mean + standard error.

Figure 16 represents a similar set of epps recorded in a d-Tc-treated preparation. In these experiments dopamine was added to examine its effects upon the storage and release of transmitter. Dopamine, unlike catechol caused a slight decrease in the amplitude of the first epp as well as a slight decrease in the amplitudes of 'tail' potentials. A further dissimilarity from catechol's action was evidenced in Table 8, which shows that dopamine did not cause a statistically significant change in any of the parameters although small changes can be seen with regard to M_0 , n , q and dm . The greatest dissimilarity lies in the fact that dopamine in d-Tc causes no change in probability of release (p) whereas catechol caused a significant increase.

Effect of catechol and dopamine upon endplate potentials in cut fiber muscle:

The cut fiber preparation of Barstad and Lilleheil (1958) was employed for the purpose suggested by the authors: "as an adjuvant tool in the study of the basic pharmacology and physiology of the myoneural junction." Therefore, results obtained with this procedure will be compared to the results obtained with the d-Tc blocked preparation.

Catechol (1×10^{-5} M) was added to the cut fiber preparation and evoked epps were recorded (Fig. 17). In five cats an increase of the epp amplitude was always obtained. The enlarged endplate potentials did not demonstrate any measureable change in either the rise-time, half-fall or membrane

potential (Table 9). Very little difference can be noted between these results in the cut fiber and those previously reported in the d-Tc blocked muscle (Table 5).

This is not the case, however when comparing the action of dopamine in the cut fiber (Table 10) with the action of dopamine in a d-Tc blocked preparation (Table 6). Figure 18 shows that dopamine like catechol (Fig. 17) greatly increases the size of evoked epps in the cut fiber preparation. Unlike catechol, dopamine caused a significant decrease in the rise-time as well as in the half-fall of the epp. These latter decreases could suggest an increase in the rate of transmitter-receptor combination and/or a decrease in the input resistance of the muscle membrane. Neither of these possibilities have been explored.

One can also observe significant differences in the responses obtained with dopamine in the cut fiber vs. those obtained in the d-Tc blocked preparation (Tables 6 and 10). In the d-Tc preparation dopamine caused a decrease of the epp which was paralleled in vivo by an exacerbation of a d-Tc induced paralysis. Dopamine in the cut fiber caused an increase of the epp which was paralleled in vivo by a slight facilitation of the contraction height in the indirectly stimulated tibialis anterior muscle. Thus in vitro d-Tc may tend to block and thus to mask a facilitatory action of the drug.

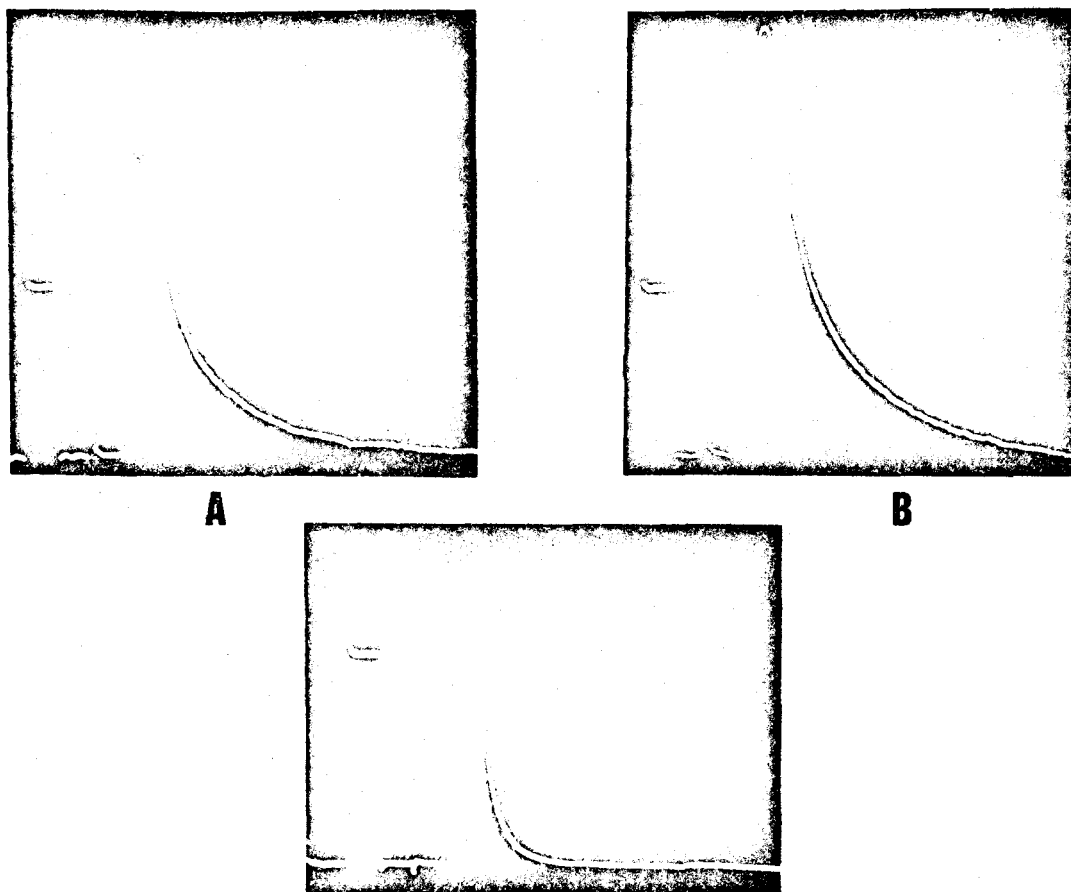

Figure 17. Epp recorded from a cut fiber preparation before (Panel A) and after (Panel B) $1 \times 10^{-5} \text{ M}$ catechol. The lower panel shows an action potential resulting from prolonged administration of the same dose of catechol. The calibration signal in A and B is $5 \text{ mV} \times 1 \text{ msec}$; in the lower panel it is $50 \text{ mV} \times 1 \text{ msec}$.

TABLE 9.

EFFECTS OF CATECHOL, $1 \times 10^{-5}M$, ON E.P.P.s IN CUT FIBER

	<u>Amplitude</u> (mV)	<u>Rise-time</u> (msec)	<u>Half-fall</u> (msec)	<u>R.P.</u> (mV)
CONTROL (N=4)	7.19 <u>+ .98</u>	0.64 <u>+ .20</u>	1.23 <u>+ .23</u>	48.4 <u>+ 7.9</u>
TREATED (N=4)	8.70* <u>+ .88</u>	0.60 <u>+ .14</u>	1.17 <u>+ .21</u>	48.4 <u>+ 8.9</u>

*The difference is statistically significant at $p < .05$.

Data pooled from four cats and expressed as mean + standard error.

**A****B**

Figure 18. Epp recorded from a cut fiber preparation before (Panel A) and after (Panel B) $1 \times 10^{-5} \text{M}$ dopamine. The calibration signal is $5 \text{mV} \times 1 \text{msec}$.

TABLE 10.

EFFECTS OF DOPAMINE, $1 \times 10^{-5} M$, ON E.P.P.s IN CUT FIBER

	<u>Amplitude</u> <u>(mV)</u>	<u>Rise-time</u> <u>(msec)</u>	<u>Half-fall</u> <u>(msec)</u>	<u>R.P.</u> <u>(mV)</u>
CONTROL (N=3)	10.67 <u>+2.55</u>	0.54 <u>+0.04</u>	1.42 <u>+0.10</u>	38.7 <u>+1.3</u>
TREATED (N=3)	16.81* <u>+5.54</u>	0.45* <u>+0.06</u>	1.30* <u>+0.18</u>	37.3 <u>+1.3</u>

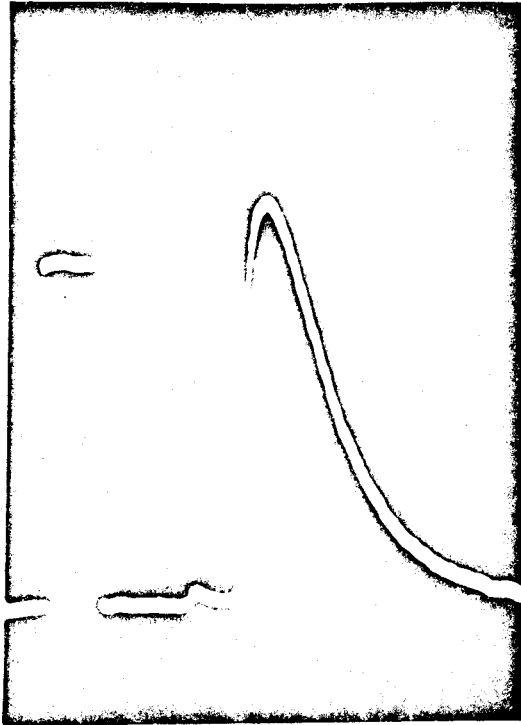
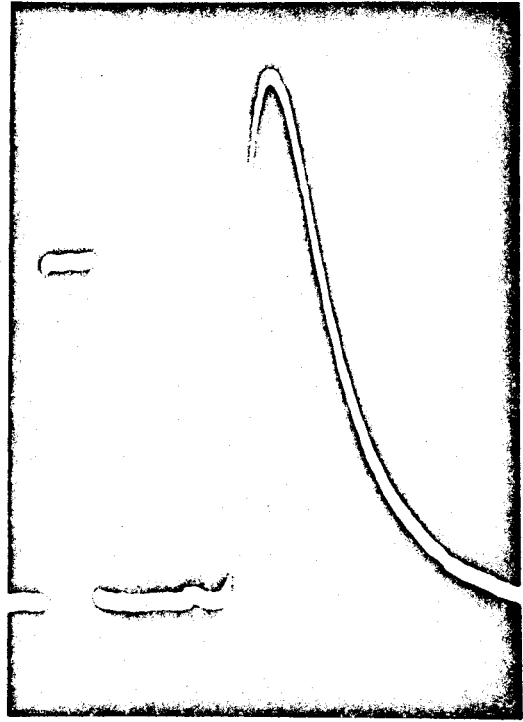
*The differences are statistically significant at $p < .05$.

Data pooled from three cats and expressed as mean + standard error.

Effect of catechol and dopamine upon storage and release of transmitter in cut fiber muscle:

In order to compare further the actions of a drug in d-Tc blocked preparations vs. cut fiber preparations catechol and dopamine were applied to cut fiber preparations stimulated at 200/sec. The effect of catechol in the cut fiber is shown in Fig. 19 which depicts a representative set of epps before and after catechol. In this preparation a visible increase in the amplitude of all the epps of the head can be observed as well as a decrease in all of the epps of the tail. As can be seen from Tables 7 and 11 the data obtained with catechol in the cut fiber preparation, although quantitatively different from those obtained in the d-Tc treated preparations, show a similar trend. In the cut fiber only the quantal content of the first epp (M_0), and probability of release (p) show a significant difference from control; these parameters were also affected by catechol in the d-Tc treated preparation. On the other hand, the quantal size (q) in the cut fiber was not depressed by catechol as it was in the d-Tc preparations. Similarly, mobilization (dm) was not altered by catechol in the cut fiber whereas it was significantly increased in the d-Tc blocked preparation.

Like catechol, results obtained with dopamine on epps recorded from cut fiber preparations stimulated at 200/sec were different from those obtained in d-Tc blocked preparations. Figure 20 shows the representative effects of dopamine on a train of epps. One can again see an increase in the

**A****B**

Figure 19. The first twelve and last ten epps recorded from a cut fiber preparation before (Panel A, top and bottom, respectively) and the first and last ten epps after (Panel B, top and bottom, respectively) $1 \times 10^{-5} M$ catechol. Stimulus frequency = 200/sec. Calibration signal = 5mV.

TABLE 11.
EFFECTS OF CATECHOL, $1 \times 10^{-5}M$, ON STORAGE AND RELEASE
OF TRANSMITTER IN CUT FIBER

	M_0 (quanta)	n (quanta)	$\frac{p}{(M_0/n)}$	q (mV)	dm (quanta/msec)
CONTROL (N=7)	214.5 <u>+16.9</u>	3028 <u>+477</u>	0.073 <u>+.017</u>	0.080 <u>+.020</u>	21.3 <u>+3.9</u>
TREATED (N=7)	315.0** <u>+29.0</u>	3128 <u>+844</u>	0.144* <u>+.039</u>	0.074 <u>+.026</u>	21.6 <u>+3.6</u>

**The difference is statistically significant at $p < .0005$.

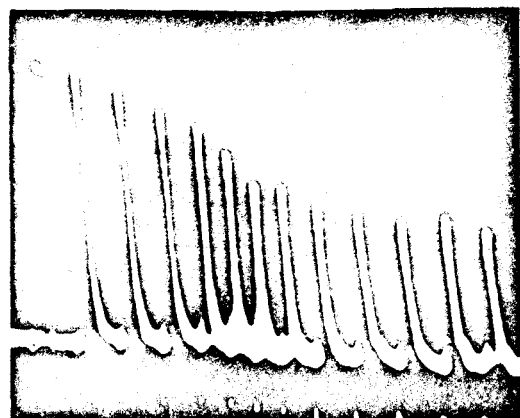
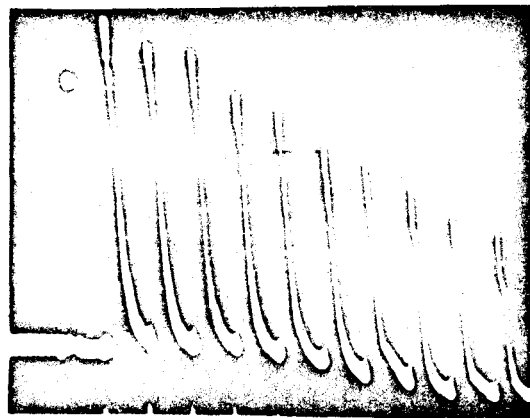
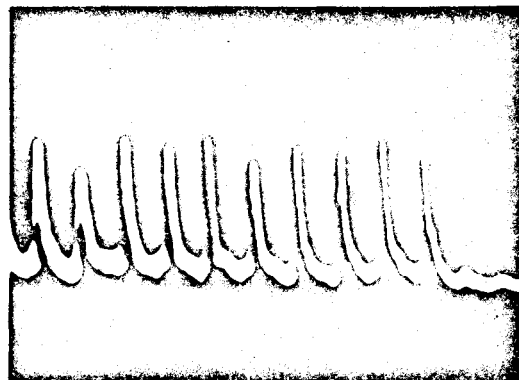
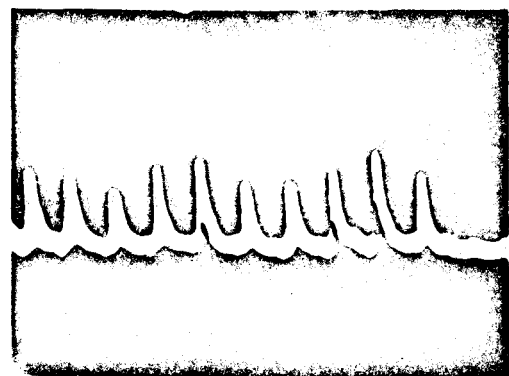
*The difference is statistically significant at $p < .05$.

Data pooled from seven cats and expressed as mean + standard error.

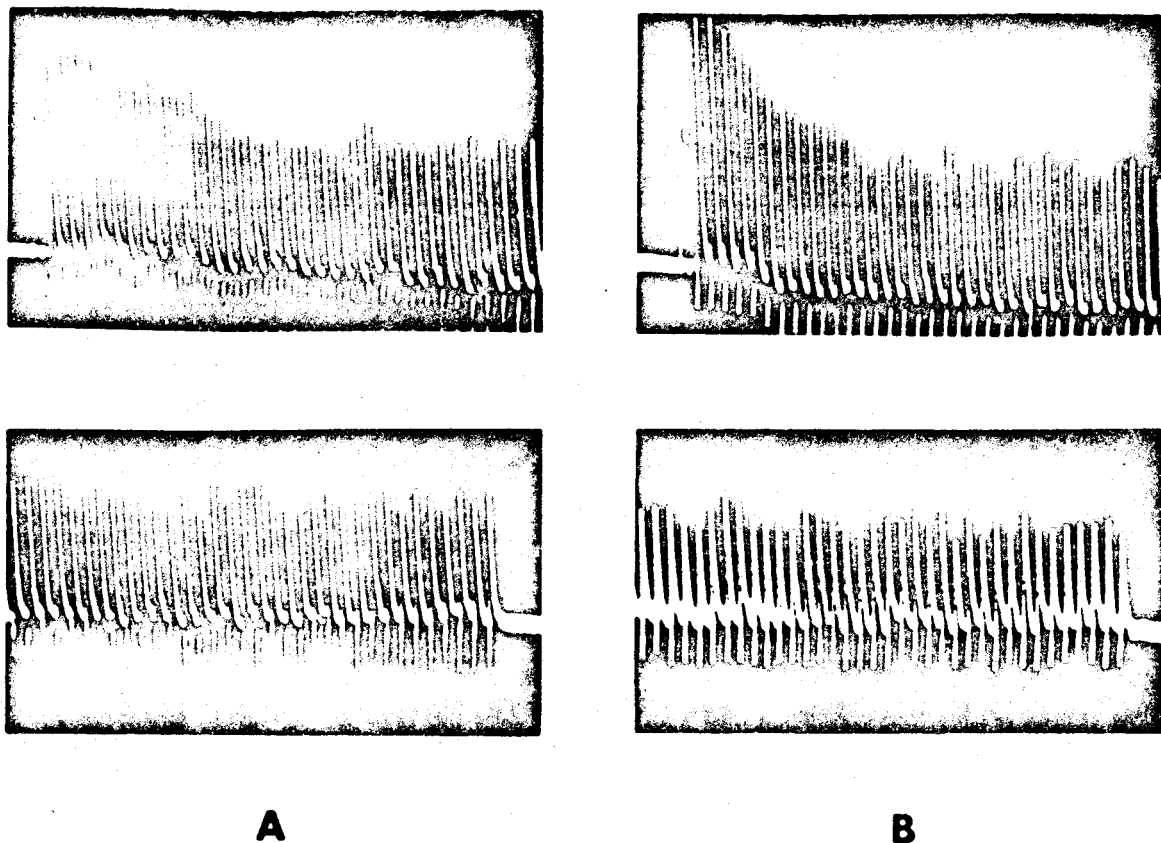

Figure 20. The first and last thirty-four epps recorded from a cut fiber preparation before (Panel A, top and bottom, respectively) and after (Panel B, top and bottom, respectively) $1 \times 10^{-5} \text{M}$ dopamine. Stimulus frequency = 200/sec. Calibration signal = 5mV.

TABLE 12.
EFFECTS OF DOPAMINE, $1 \times 10^{-5} M$, ON STORAGE AND RELEASE
OF TRANSMITTER IN CUT FIBER

	M_0 (quanta)	n (quanta)	p (M_0/n)	q (mV)	dm (quanta/msec)
CONTROL (N=3)	199.7 <u>+40.2</u>	2736 <u>+573</u>	0.073 <u>+0.002</u>	0.097 <u>+0.026</u>	16.3 <u>+3.2</u>
TREATED (N=3)	302.2* <u>+65.3</u>	3163 <u>+618</u>	0.108 <u>+0.041</u>	0.069* <u>+0.031</u>	21.9 <u>+3.7</u>

*The differences are statistically significant at $p < .05$.

Data pooled from three cats and expressed as mean + standard error.

amplitude of the first few epps as well as a steeper run-off to a relatively steady-state in which the amplitude of the tail epps are slightly depressed compared to control epps. Similar data were obtained in three different cats and these data are summarized in Table 12. A significant increase is obtained in the quantal content of the first epp (M_0); the size of each quantum (q) was significantly decreased. Unlike catechol, dopamine did not cause a significant increase in the probability of release (p). Dopamine did cause a larger increase in mobilization (dm) and readily available stores (n) than did catechol in the cut fiber preparation. Dopamine in the cut fiber produces significant changes in the quantal content of the first epp (M_0) and the quantal size (q) which are not evident in the presence of d-Tc. D-Tc also acts to depress the increase in probability of release (p) caused by dopamine in the cut fiber preparation. The other parameters, n and dm , are affected by dopamine similarly in both the d-Tc preparation as well as the cut fiber preparation.

Effect of catechol upon equilibrium potential and effective membrane resistance in cut fiber muscle:

In a final effort to disclose a possible postsynaptic action for catechol at the neuromuscular junction measurements of muscle input resistance and equilibrium potential were performed. Using the technique of Fatt and

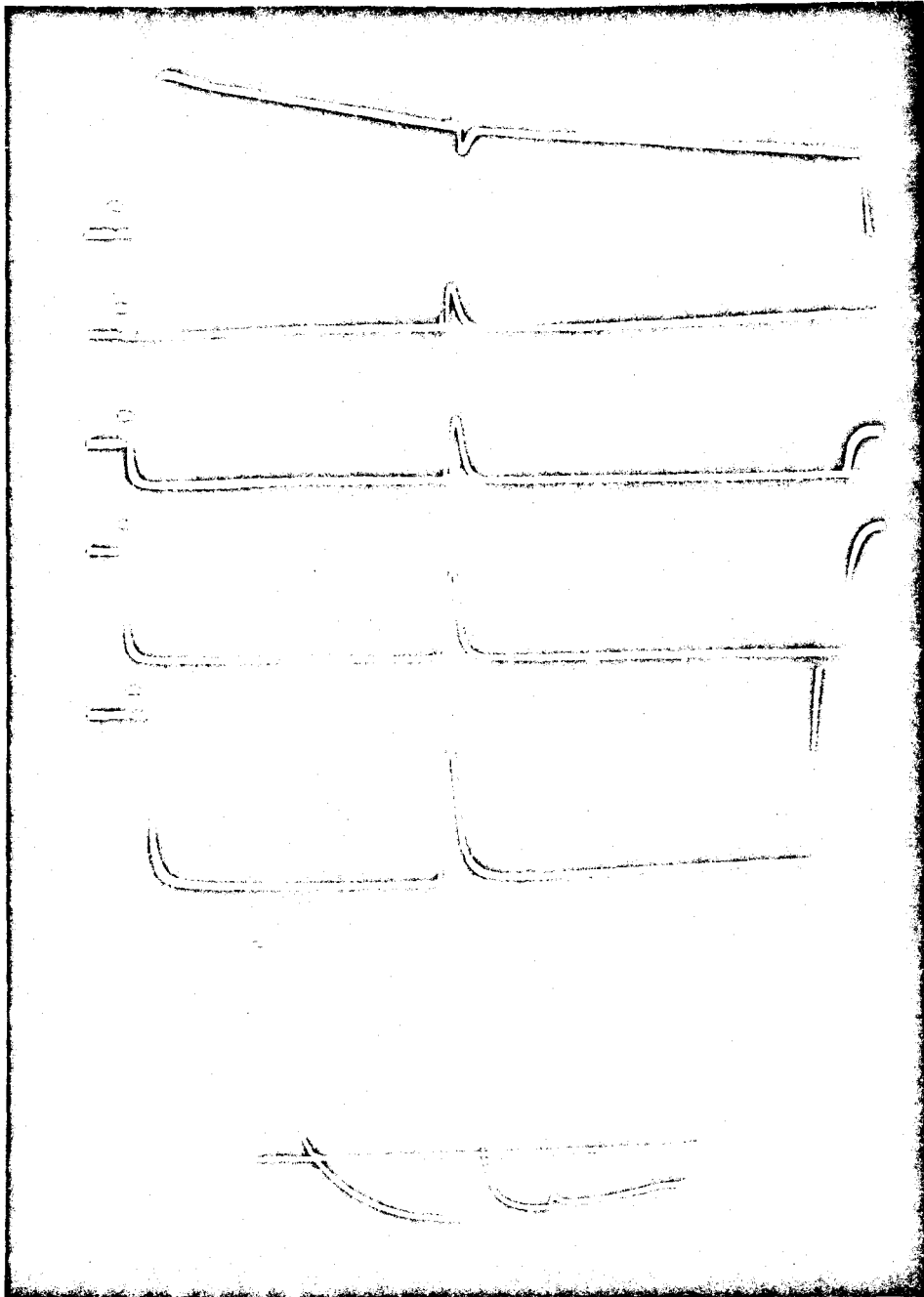

Figure 21. The second tracing represents a control epp in a cut fiber preparation. Tracings 1, 3, 4, 5, and 6 are electrotonic potentials induced by increasing current pulses. In the middle of these electrotonic potentials an epp has been evoked. The uppermost figure demonstrates a reversal of the epp with a depolarizing current pulse; the lower figures show the effects of hyperpolarizing current pulses. The calibration signal is 5mV x 1msec.

Katz (1951) it was possible to determine simultaneously these parameters. These experiments were conducted using the cut fiber preparation for two reasons. 1) Since the preparation is not complicated by other drugs a more accurate estimate of catechol's effects on the input resistance or equilibrium potential should be obtained. 2) An accurate estimate of the equilibrium potential was necessary in using the computer analysis to determine a drug effect upon storage and release of transmitter. Prior to this, there has been no report of equilibrium potential values at mammalian neuromuscular junctions, so that this estimate was needed. As can be seen (Table 13), the resting potentials were low compared to the data of others on the cut fiber preparation. The 'normal' resting potential for a cut fiber preparation was reported as being in the range of -40 to -50 mV. However, the insertion of the second electrode usually will cause a drop of this resting potential (Fatt and Katz, 1951; Boyd and Martin, 1956b).

A control epp and a series of electrotonic potentials with evoked end-plate potentials are shown in Figure 21. Utilizing the electrotonic potential and current signals, the effect of catechol upon muscle input resistance was determined (cf. Methods). The results obtained from one of five animals is plotted in Figure 22. The individual points are not significantly different from each other in control and treated preparations. The mean values +

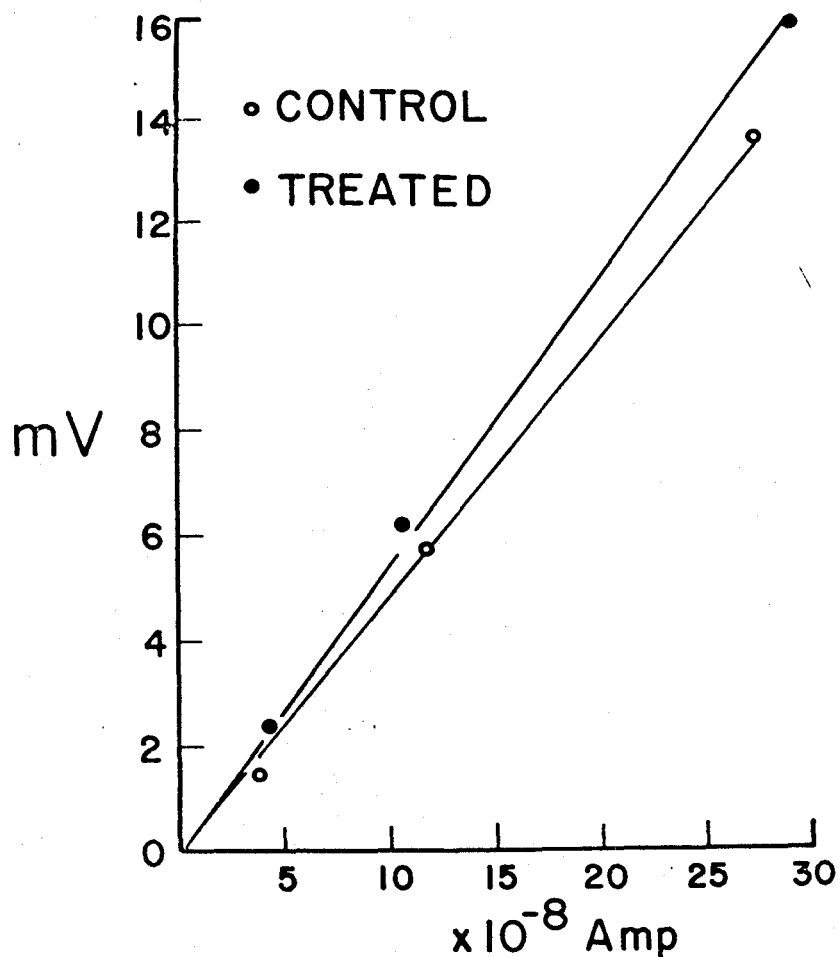

Figure 22. Effect of catechol, $1 \times 10^{-5}M$, on effective membrane resistance. The resistance was calculated from the electrotonic potential change produced by intracellularly applied hyperpolarizing currents.

standard error obtained in control and preparations treated with catechol ($1 \times 10^{-5} \text{M}$) were $3.8 \pm 0.5 \times 10^5$ and $4.1 \pm 0.8 \times 10^5$, respectively.

The equilibrium potential may be defined as that level of membrane potential at which the inward sodium current is equally and oppositely balanced by the outward potassium current. This results in an inability to produce an epp after supramaximal indirect stimulation.

From the same experiments, an estimate of the equilibrium potential before and after catechol was obtained. An example of the results collected from one of the five animals is plotted in Figure 23. Similar control values were recorded by Takeuchi and Takeuchi (1959) using a d-Tc blocked frog muscle preparation. Catechol ($1 \times 10^{-5} \text{M}$) did not significantly affect the normal equilibrium potential of the cut fiber preparation (Table 13).

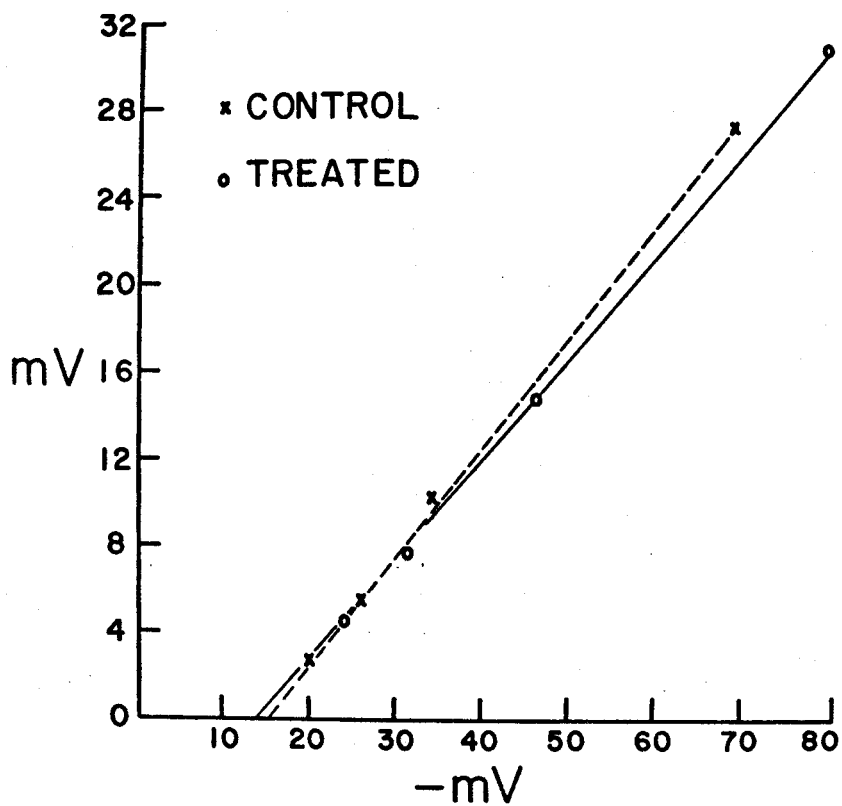

Figure 23. Effect of $1 \times 10^{-5} \text{M}$ catechol on the equilibrium potential of a cut fiber preparation. Control = -16mV . Treated = -14mV .

TABLE 13.
EFFECTS OF CATECHOL, $1 \times 10^{-5} M$, ON EXTRAPOLATED EQUILIBRIUM
POTENTIAL IN CUT FIBER

	Control <u>-mV</u>	Treated <u>-mV</u>	Resting Potential <u>-mV</u>
CAT I	10.0	13.5	20.0
CAT II	14.0	6.5	24.0
CAT III	16.0	13.5	24.0
CAT IV	19.5	22.0	36.0
CAT V	13.5	10.0	22.0
MEAN	14.6	13.1	25.2
<u>+S.E.</u>	<u>+1.6</u>	<u>+2.6</u>	<u>+2.8</u>

The differences are not statistically significant.

DISCUSSION

d-Tc antagonism - in vivo

The results obtained from in vivo studies with the cat anterior tibialis muscle demonstrate that catechol or phenol reverse the paralyzing action of d-Tc. These data support the earlier report of Mogey and Young (1949), who used the rat diaphragm. Prior treatment with alpha- or beta-adrenoreceptor blocking compounds did not alter the anti-d-Tc action of catechol or phenol. In contrast, epinephrine, although it initially appears to antagonize the d-Tc paralysis, causes a secondary depression and dopamine produces enhancement of the d-Tc blockade. Results with epinephrine support the work of Naess and Sirnes (1953); the d-Tc-like action of dopamine was already reported by Blum (1969). When an alpha-receptor blocking agent is given prior to d-Tc, the anti-d-Tc action of epinephrine is abolished (Maddock et al., 1948; Bowman and Raper, 1966; 1967). However, prior treatment with a beta-receptor blocking agent does not alter the anti-d-Tc action of epinephrine (Bowman and Raper, 1966).

I should like to suggest on the basis of the relation between the structures of the four compounds, phenol, catechol, epinephrine and dopamine (Fig. 4) and their anti-d-Tc action that the addition of the ethylamine or ethanolamine side chain tends to decrease the presynaptic action and mask it with an overriding postsynaptic d-Tc-like action.

Anti-benzoquinonium action - in vivo

Bowman (1958) reported that benzoquinonium acted as a competitive blocker at the neuromuscular junction, and that this action could be antagonized by epinephrine. Benzoquinonium was also demonstrated to prevent the facilitatory action of some anti-ChEs (Bowman, 1958; Blaber and Bowman, 1962; Christ and Blaber, 1968), especially those possessing a presynaptic facilitatory action (Blaber and Christ, 1967). Bowman and Blaber (1962) concluded that anti-ChE facilitatory drugs were unable to antagonize a benzoquinonium paralysis. That this was not due to the anti-ChE effect of benzoquinonium was shown previously by Karczmar (1961). In the present experiment, it was observed that the neuromuscular blockade produced by benzoquinonium could be antagonized by catechol or phenol; it can be concluded that catechol, phenol or epinephrine do not occupy the same presynaptic site as the anti-ChE-type of facilitatory drugs.

Effects on maximum contractions - in vivo

Catechol (2.9%), phenol (9%) or dopamine (10%) had little facilitatory effect upon the indirectly stimulated muscle contraction. In contrast, epinephrine has been repeatedly shown to cause a significant facilitatory response on fast muscle and a depressant response on slow muscle (Bowman and Zaimis, 1958). Blum (1969) using the anterior tibialis muscle reported

that dopamine caused a high incidence of depressant action with a certain incidence of either no effect or a slight facilitation. Ferko and Calesnick (1971) using a different muscle, the gastrocnemius, reported a depressant action of dopamine. This latter response (Ferko and Calesnick, 1971) may be attributable to the presence of about 50% slow fibers in the gastrocnemius muscle. As in the case of the experiments of Blum (1969) dopamine was administered by Ferko and Calesnick (1971) in higher doses than I used; both investigators also employed an i. v. rather than the close-arterial route of administration. It might be possible that the responses obtained by these authors were due to a dopamine metabolite, rather than dopamine itself. Ferko and Calesnick (1971) were able to show a depressant effect with dopamine after prior treatment with either an alpha- or beta-receptor blocking compound.

Neither catechol nor phenol produced a contraction of the muscle when injected close-arterially into the innervated or into the chronically or subacutely denervated muscle. In higher doses, however, both catechol and phenol produce a biphasic response consisting of a partial block and facilitation or else simply block. When a block was obtained, a contracture of the muscle could be recorded similar to that seen with appropriate doses of depolarizing or anticholinesterase agents. No fibrillations were ever recorded in chronically denervated muscles after the addition of either

compound. It may be concluded from these results that catechol or phenol do not stimulate the muscle by a direct depolarizing action.

Okamoto and Riker (1969) have proposed a technique of 48-hour denervation to evaluate selectively motor nerve terminal responsiveness. This preparation demonstrated a severe reduction in the ability to respond to repetitive stimulation but the single impulse transmission did not appear to be affected seriously. At 48 hours Okamoto and Riker also reported absence of denervation sensitization. Using this technique I could show that catechol or phenol were greatly reduced in their effectiveness to antagonize d-Tc. This suggested that the nerve terminal may be the site of drug action. This conclusion supports that of Otsuka and Nonomura (1963) who used the isolated frog sartorius muscle.

Effects on responses to close-arterially injected ACh

Bowman and Raper (1967) demonstrated that during the antagonism of d-Tc by epinephrine contractions resulting from close-arterial injections of acetylcholine are depressed throughout the whole effect of epinephrine. They concluded that the postsynaptic effect of epinephrine was to decrease the sensitivity of the muscle to ACh and that the anti-d-Tc action of epinephrine could best be explained via a presynaptic mechanism which would involve the increase in the quantity of ACh released per nerve impulse.

In this investigation, ACh responses were depressed during initial d-Tc reversal due to epinephrine; as the anti-d-Tc action ensued, the ACh contractions became normalized. It does not appear that catechol depresses or increases the responsiveness of the muscle membrane to ACh. It can therefore be concluded that catechol neither "sensitizes" the receptor to the action of ACh, nor inhibits ChE (Blaber, 1963).

Effects of blood flow

Muscle blood flow recordings have shown that the effects of catecholamines on neuromuscular transmission are independent of the vascular changes produced (Bowman and Raper, 1966). Dopamine's depression of muscle contractility was independent of blood flow changes as reported by Ferko and Calesnick (1971). From my results of blood flow measurement during the administration of catechol or phenol it appears that their action at the neuromuscular junction are also independent of the accompanied vasoconstriction.

Effects of drug combinations with neostigmine and aminophylline - in vivo

Breckenridge et al. (1967) have concluded that epinephrine augments the contractions of unblocked muscle by a beta-receptor action which could be potentiated by neostigmine and aminophylline. As was pointed out by

Bowman and Nott (1969) the beta-receptor blocking drug used in their study, propranolol, which I used, has a strong local anesthetic action (Usubiaga, 1968). Standaert and Roberts (1967) have shown that propranolol abolished postsynaptic repetitive firing in the cat soleus muscle and nerve by an action unrelated to blockade of beta-receptors, and a similar action may account for the observation that it abolished twitch potentiation produced by a combination of neostigmine and epinephrine (cf. also Breckenridge et al., 1967). I have repeated these experiments and have obtained similar results to those reported by Breckenridge et al. (1967); I feel however that another beta-receptor blocking compound should be examined, such as MJ 1999. Propranolol does not effect the potentiating action of aminophylline as evidenced by prior administration to combinations of aminophylline + catechol + neostigmine or aminophylline + phenol + neostigmine (Table 2). Similarly, prior administration of phenoxybenzamine does not alter the potentiating action of aminophylline + catechol + neostigmine or aminophylline + phenol + neostigmine (Table 2).

Conclusions from in vivo studies

From these in vivo studies I have concluded that there is some evidence suggesting a difference in the mode of action of anti-ChEs, epinephrine, dopamine and catechol or phenol. All of the compounds except dopamine antagonize a d-Tc paralysis. Anti-ChEs and catechol or phenol

will reverse a d-Tc paralysis in the presence of an alpha-adrenoceptor blocking agent. Catechol or phenol and epinephrine will antagonize a benzoquinonium block; anti-ChEs will do it only to a limited degree (Karczmar, 1961). All of the compounds will facilitate muscle contraction, epinephrine being the most potent. Epinephrine, catechol or phenol do not increase the responses to close-arterially injected ACh whereas anti-ChEs increase this response. Aminophylline with catechol or phenol + neostigmine combinations still potentiate muscle contractions after pre-treatment with either an alpha- or beta-receptor blocking agent whereas these blockers attenuate significantly the ability of aminophylline with epinephrine + neostigmine combinations to potentiate muscle contractions. Finally, it appears that both catechol and phenol act via the same mechanism and at the same site. In all instances when both compounds - catechol and phenol - were tested parallel results were obtained. The only difference that was noted was that of potency (catechol 5x phenol).

With this evidence as the background, electrophysiological studies were begun in vitro to elucidate the precise site, as well as, the mechanism of action of catechol and phenol. It should always be kept in mind that the purpose of this investigation was to gain insight into the facilitatory action of the catecholamines at the neuromuscular junction. Since the results

obtained with either catechol or phenol differ only as to the potency of each, it was decided to continue the study using only catechol and compare its actions in vitro to chemically the most similar and simplest catecholamine, dopamine (Fig. 4).

Effects upon mepps - in vitro

Katz (1962) concluded that since mepps are of a presynaptic origin, their frequency can only reflect presynaptic events. In the in vitro preparation treated with various doses of catechol a statistically significant increase in mepp frequency was observed indicating a presynaptic site of action. Kuba (1969) observed a large increase in mepp frequency with phenol at the fish neuromuscular junction.

Changes in the amplitude of mepps may reflect both pre- and post-synaptic factors. Since catechol did not change the amplitude of mepps it was concluded that it must have only a presynaptic site of action. However, very few compounds act only at one site so that a postsynaptic site of action was further examined. In measuring mepp amplitude, individual mepps were also analyzed for changes in time course, i. e. rise-time and half-fall. None could be found. There have been reports (Krnjevic and Miledi, 1958; Jenkinson, Stamenovic, and Whitaker, 1968; and Kuba, 1971) that catechol-

amines which activate the alpha-receptor increased the frequency of mepps, while catecholamines which activate the beta-receptor increase both the frequency and amplitudes of mepps. Thus on the basis of mepp analysis it appears that catechol is similar to the alpha-receptor activators in having a presynaptic action and that it differs from the beta-receptor activators as it does not augment the amplitude of mepps.

Effects on epps in d-Tc

Catechol increases the amplitude of epps recorded in the presence of d-Tc, without changing their time course. It also does not change the recorded resting membrane potential. These results confirm the reports of Otsuka and Nonomura (1963) at the frog neuromuscular junction, and resemble the results obtained with phenol by Kuba (1969) at the fish neuromuscular junction. All these authors concluded that this augmentation of the epp amplitude was due to an increase in the release of transmitter released from the nerve endings. They further rule out the possibilities that phenol or catechol might either have anti-ChE activity or else sensitize the post-synaptic membrane to ACh; indeed, they did not show any change in the configuration of the ACh potential in the presence of catechol (Otsuka and Nonomura, 1953) or phenol (Otsuka and Nonomura, 1963; Kuba, 1969).

Hutter and Loewenstein (1955), Krnjevic and Miledi (1958), Jenkinson et al. (1968) and Kuba (1970) demonstrated that epinephrine or norepinephrine increased the amplitudes of epps recorded in the presence of d-Tc or high concentrations of magnesium. Jenkinson et al. (1968) and Kuba (1970) suggest that the increased amplitude of epps recorded in the presence of epinephrine or norepinephrine is due to an action at a presynaptic alpha-adrenoceptor. Supporting evidence included the ability to inhibit this facilitatory action with an alpha-receptor blocking agent. Results with dopamine show either no effect or a slight depressant action upon the amplitude of epps recorded in d-Tc; the half-fall was slightly prolonged. This effect upon the half-fall may be attributed to an alteration in the passive membrane properties, eg. resistance, or the drug may desensitize the membrane to ACh. Kuba (1969) has demonstrated that phenol does not modify the input resistance of the postsynaptic membrane. However, catecholamines which activate the beta-receptor increase the membrane resistance (Kuba, 1970).

Kuba (1970) demonstrated that epinephrine and isoproterenol caused a significant increase in the resting potential; norepinephrine did not. On the other hand, Christ and Nishi (1971) reported that epinephrine did not hyperpolarize the postsynaptic membrane of the rabbit cervical ganglion. They demonstrated that epinephrine decreased the frequency of miniature excita-

tory postsynaptic potentials (this latter action being antagonized by the alpha-receptor blocking agents, phenoxybenzamine or dihydroergotamine). Libet (1970) has proposed that dopamine is the catecholamine transmitter responsible for activation of the inhibitory cholinceptive site of the ganglion resulting in hyperpolarization.

I should like to suggest that the addition of the ethanalamine side chain acts to change the basic catechol action in a d-Tc preparation from one of facilitation at the nerve terminal to a mixed action; depression predominated over the facilitation when the side chain is reduced to ethylamine. There also appears to be a shift to a postsynaptic site of action which tends to mask the underlying presynaptic site.

Effects on storage and release of transmitter in d-Tc

In an effort to define better the site and mechanism of catechol's anti-d-Tc effect, trains of epps were analyzed for transmitter release phenomena - quantal content of the first epp (M_0), readily releasable stores (n), probability of release (p), quantal size (q), and mobilization (dm). Catechol (Table 7) significantly increased all the parameters analyzed with the exception of readily available stores (n) and quantal size (q). These results support the conclusion of Otsuka and Nonomura (1963) in their experiments with catechol and phenol, and also the conclusion of Kuba (1969)

in his experiments with phenol, that these agents cause an increase in the probability of release of transmitter. The increased quantal content of the first epp of the trains follows from the increased probability of release (p), i. e. is due to the amount of quanta/impulse. My data also supports the suggestion made by Otsuka and Nonomura (1953) that phenolic compounds do not change the amount of the store of available transmitter. This combination of action, an increased probability of release and little change in the amount of the store of available transmitter may explain the observed decrease in the amplitude of the tail epps after catechol. In this context, it should be emphasized that Potter (1968) demonstrated that the newly formed transmitter is the first to be released on demand. Thus, a "younger" quantum that is forced to be released may not contain the same amount of transmitter as a more "mature" quantum.

In the case of dopamine in d-Tc preparations there is no significant change in any of the storage and release parameters (Table 8). Although the probability of release remains constant, the readily available stores tend to increase; this is similar to the effect observed after catechol. This increase in n may account for the observed increase in quantal content after dopamine. The decrease in quantal size could be explained by a post-synaptic d-Tc-like action rather than by an increased probability of release without a sufficient increase in mobilization which was suggested for catechol. It appears that the addition of the side chain to the catechol

nucleus tends to decrease the facilitatory action of these compounds.

Effects on epps in cut fiber muscle

The final series of experiments were employed to examine catechol's and dopamine's effect upon neuromuscular transmission in the absence of d-Tc. It has been suggested that since d-Tc not only has a powerful post-synaptic action but also a weak presynaptic action as well, its presence in the control solution does not really yield "control" results. The same should also be noted for experiments done in the presence of Ringer solutions containing high magnesium concentrations.

In cut fiber preparations catechol produced a significant increase in the amplitude of epps without changing their time course. It did not change the recorded resting membrane potentials. Thus far these results mirror those observed in the presence of d-Tc.

Dopamine also produced a significant increase in epps recorded with the cut fiber preparation, but this facilitation was complicated by the change in the time course of these epps. Dopamine did not change the recorded resting potentials.

Effects on storage and release of transmitter in cut fiber muscle

Upon examination of trains of epps in the cut fiber preparation a slightly different picture emerges as compared to the results obtained with

the d-Tc blocked preparation. In the cut fiber experiments the only significant changes observed were increases in the quantal content of the first endplate potential (M_0) and an increase in the probability of release (p). The other parameters (n , q , dm) all remain more or less constant (Table 11). The fact that there is no change in the quantum size mirrors the results obtained with mepps wherein no change in amplitude was observed after the addition of the drug. It should be noted that the values obtained for the probability of release in both control and treated preparations are below the values of the "control", i. e. the d-Tc blocked preparation, while the values for mobilization are well above comparable values obtained in the d-Tc blocked preparation. These parameters indicate that indeed d-tubocurarine has a presynaptic action that is apparently facilitatory in effect. Actually, the high increase in probability of release as well as the low rate of mobilization tend to add to the classical postsynaptic blocking action of d-Tc. Catechol, therefore, tends to have a more significant role in the presence of d-Tc than it does in its absence. This latter effect in fact corresponds to the effects of catechol obtained in vivo.

In the case of dopamine in the cut fiber preparation (Table 12), one observes an increase in the quantal content of the first epp (M_0); as in the d-Tc blocked preparation this may be due to the slight increase in the

amount of readily available stores (n). Unlike with d-Tc treated preparations, one can observe in the cut fiber preparation a slight increase in the probability of release (p) as well as in the rate of mobilization (dm). There is a significant decrease in the size of each quantum (q) which may be due to dopamine's "curaremimetic" action as observed in the d-Tc blocked muscle. An alternative explanation for this depression in quantal size may be similar to that suggested for catechol; i. e. the depression may be due to an increased 'p' leading to an increased quantal content of the first epp (M_0) without a sufficient concomitant increase in the readily available store. The net result would be a utilization of less "mature" quanta. In either case, the cut fiber data tends to expose actions of these compounds at the neuromuscular junction which may be masked by the presence of d-Tc.

Once again, catechol, per se, appears to have a pure presynaptic facilitatory action while the compounds with an added ethanolamine or ethyl amine side chain possess a stronger postsynaptic action which tends to override any presynaptic facilitatory effects.

Effects on equilibrium potential and effective membrane resistance

A final series of experiments was conducted to ascertain possible catechol induced changes in the passive membrane properties as well as the equilibrium potential of the muscle. These experiments were

conducted using the cut fiber preparation in order to avoid any complications that might arise due to the presence of d-Tc. Similar to the results of Kuba (1969) using phenol at the slow fish muscle not treated with d-Tc, catechol did not cause a change in input resistance of the muscle fiber. Likewise, I was not able to demonstrate any significant alteration by catechol of the equilibrium potential measurements. Kuba (1970) has demonstrated that alpha-receptor stimulating catecholamines do not cause a change in the passive membrane properties of the rat diaphragm; the catecholamines which stimulate the beta-receptor cause an increase in the membrane resistance. This latter effect on the other hand might account for the slight prolongation that was recorded in the half-fall of epps with dopamine.

Might it be that in certain muscle diseases this particular potential level (the equilibrium potential) is affected such that normal propagation is inhibited?

Possible applications

Facilitatory drugs other than anti-ChEs have been used clinically with little success. This deficiency has been primarily due to the lack of availability of a drug which at a specific site possesses a potent facilitatory action. As mentioned earlier, "A drug that is active at one site acts to some degree at all other sites . . ." (Karczmar and Blaber, 1967).

Catechol may serve as a useful tool in the development of a specific potent facilitatory drug. An example of an application for such a compound would be in myasthenia gravis. A compound if not sufficiently potent of itself could be administered in combination with synergistic agents. Using catechol as an example such a combination could involve the anti-ChE, neostigmine, and the methylxanthine, aminophylline. These drug combinations would then allow a lower dose of each to be used, resulting in an enhanced therapeutic effect with minimal untoward effects. This speculation is being tested clinically in our laboratories.

CONCLUSION

The facilitatory action of catechol and phenol was investigated using the cat anterior tibialis muscle preparation. Catechol was further investigated at the cat tenuissimus muscle utilizing standard microelectrode techniques. Analysis of data from these experiments has resulted in the following conclusions:

- 1) Catechol or phenol will antagonize a d-tubocurarine paralysis by a mechanism that is not affected by either alpha- or beta- adrenoreceptor blocking agents.
- 2) Both compounds antagonize a benzoquinonium paralysis.
- 3) In doses which reverse either a d-tubocurarine or benzoquinonium paralysis, catechol or phenol do not have a direct action on the muscle fiber.
- 4) Neither agent sensitizes post-junctional receptors to acetylcholine or inhibits acetylcholinesterase.
- 5) Catechol and phenol act at a common site via a common mechanism.
- 6) Catechol will increase the frequency of miniature endplate potentials without altering their time course.
- 7) The amplitude of endplate potentials are increased by catechol either in a muscle blocked with d-tubocurarine or in a cut fiber muscle.
- 8) In the presence of d-tubocurarine, catechol caused a significant increase in the probability of release, the quantal content of the first endplate potential and the mobilization rate.

- 9) In the cut fiber preparation, catechol caused a significant increase in the probability of release and the quantal content of the first endplate potential.
- 10) Neither the normal input resistance nor the equilibrium potential are affected by catechol.
- 11) The facilitatory action of catechol or phenol could only be assigned to a presynaptic site of action. A possible mechanism whereby this facilitatory action occurs has been suggested.

BIBLIOGRAPHY

- Adrian, E. D. (1925). The spread of activity in the tenuissimus muscle of the cat and in other complex muscles, *J. Physiol.* (London), 60, 301-315.
- Ahlquist, R. P. (1948). A study of adrenotropic receptors, *Am. J. Physiol.* 153, 586-600.
- Angel, A., Lemon, R.N., Robers, K.J., Banks, P. (1969). The effect of polyhydroxyphenols on brain ATP in the mouse, *Exp. Brain Res.*, 7, 250-257.
- Auerbach, A. and Betz, W. (1971). Does curare effect transmitter release? *J. Physiol.* (London), 213, 691-706.
- Axelrod, J., In: Ciba Foundations on Adrenergic Mechanisms, Churchill, London, pp. 28-39 (1960).
- Axelrod, J. and Tomchik, R. (1958). Enzymatic o-methylation of epinephrine and other catechols, *J. Biol. Chem.*, 233, 702-705.
- Bacq, Z. M. (1949). Metabolism of adrenalin, *Pharmacol. Rev.*, 1, 1-26.
- Bacq, Z. M. and Brown, G. L. (1937). Pharmacological experiments on mammalian voluntary muscle, in relation to the theory of chemical transmission, *J. Physiol.* (London), 89, 45-60.
- Bacq, Z. M., Gosselin, L., Dresse, A. and Renson, J. (1959). Inhibition of O-methyltransferase by catechol and sensitization of epinephrine, *Science*, 130, 453.
- Barger, G. and Dale, H. H. (1910). Chemical structure and sympathomimetic action of amines, *J. Physiol.* (London), 41, 19-59.
- Barnett, R. J. (1962). The fine ultrastructural localization of acetylcholinesterase at the nyoneural junction, *J. Cell Biol.*, 12, 247-262.
- Barstad, J. A. B. and Lilleheil, G. (1968). Transversally cut diaphragm preparation from rat, *Arch. Int. Pharmacodyn. Ther.*, 175, 373-390.

- Bass, L. and Moore, W.J. (1966). Electrokinetic mechanism of miniature postsynaptic potentials, *Proc. Nat. Acad. Sci.*, 55, 1214-1217.
- Beani, L., Bianchi, C., and Ledda, F. (1964). The effect of d-tubocurarine on acetylcholine release from nerve terminals, *J. Physiol. (London)*, 174, 172-183.
- Bennett, H.S. (1956). The concepts of membrane flow and membrane vesiculation as mechanisms for active transport and ion pumping, *J. Biophys. Biochem. Cytol.*, 2, Suppl. 99-103.
- Beranek, R. and Vyskocil, F. (1967). The action of tubocurarine and atropine on the normal and denervated rat diaphragm, *J. Physiol. (London)*, 188, 53-66.
- Bernard, C.R. (1851). Action de curare et de la nicotine sur le systeme nerveux et sur le systeme musculaire, *Compt. Rend. Soc. Biolog. Paris*, 2, 195.
- Birks, R.I. (1963). The role of sodium ions in the metabolism of acetylcholine, *Can. J. Biochem. Physiol.*, 41, 2573-2579.
- Birks, R.I., Burstyn, P.G.R. and Firth, D.R. (1968). The form of sodium-calcium competition at the frog myoneural junction, *J. Gen. Physiol.*, 52, 887-907.
- Birks, R.I. and Cohen, M.W., Effects of sodium pump inhibitors on myoneural transmission in the frog, In: Symposium on Muscle, Edit. by W.M. Paul, E.E. Daniel, C.M. Kay and G. Manckton, Academic Press, New York, (1965)
- Birks, R.I. and MacIntosh, F.C. (1957). Acetylcholine metabolism at nerve endings, *Brit. Med. Bull.*, 13, 157-161.
- Birks, R.I. and MacIntosh, F.C. (1961). Acetylcholine metabolism of a sympathetic ganglion, *Canad. J. Biochem. Physiol.*, 39, 787-827.
- Blaber, L.C. (1960). The antagonism of muscle relaxants by ambenonium and methoxyambenonium in the cat, *Brit. J. Pharmacol. Chemother.*, 15, 476-484.

- Blaber, L.C. (1963). Facilitation of neuromuscular transmission by anti-cholinesterase drugs, *Brit. J. Pharmacol. Chemother.*, 20, 63-73.
- Blaber, L.C. (1970). The effect of facilitatory concentrations of decamethonium on the storage and release of transmitter at the neuromuscular junction of the cat, *J. Pharmacol. Exp. Ther.*, 175, 664-672.
- Blaber, L.C. and Christ, D.D. (1967). The action of facilitatory drugs on the isolated tenuissimus muscle of the cat, *Int. J. Neuropharmacol.*, 6, 473-484.
- Blaber, L.C. and Goode, J.W. (1968). A comparison of the action of facilitatory and depolarizing drugs at the mammalian motor nerve terminal, *Int. J. Neuropharmacol.*, 7, 429-440.
- Blaber, L.C. and Karczmar, A.G. (1967). Multiple cholinceptive and related sites at the neuromuscular junction, *Ann. N.Y. Acad. Sci.*, 144, 571-583.
- Blaber, L.C. and Karczmar, A.G. (1967). Interaction between facilitatory and depolarizing drugs at the neuromyal junction of the cat, *J. Pharmacol. Exp. Ther.*, 156, 55-62.
- Blackman, J.G., Ginsborg, B.L. and Ray, C. (1963). On the quantal release of the transmitter at a sympathetic synapse, *J. Physiol. (London)*, 167, 402-415.
- Bloedel, J., Gage, P.W., Llinas, P. and Quastel, D.M.J. (1966). Transmitter release at the squid giant synapse in the presence of tetrodotoxin, *Nature*, 212, 49-50.
- Blum, K. (1969). The effect of dopamine and other catecholamines on neuromuscular transmission, *Arch. Int. Pharmacodyn.*, 181, 297-306.
- Bowman, W.C. (1958). The neuromuscular blocking action of benzoquinonium in the cat and in the hen, *Brit. J. Pharmacol. Chemother.*, 13, 521-530.
- Bowman, W.C. (1959). A comparison between the vascular responses to adrenaline and noradrenaline in individual skeletal

muscles of the cat. *J. Pharm. Pharmacol.*, 11, 104-119.

- Bowman, W.C., Mechanisms of neuromuscular blockade, In: Progress in Medicinal Chemistry, Edit. G.P. Ellis and G.B. West, Butterworth, London, pp. 88-131, (1962).
- Bowman, W.C., In: Evaluation of Drug Activities: Pharmacometrics, Edit. D.R. Laurence and A.L. Bachrach, Academic Press, London, 1, 325-351, (1964).
- Bowman, W.C. (1959) The effect of muscle contractions on the blood flow and the vascular responses to adrenaline, noreadrenaline and isoprenaline in individual skeletal muscles of the cat, *J. Pharm. Pharmacol.*, 11, 641-649.
- Bowman, W.C., Goldberg, A.A.J. and Raper, C. (1962). A comparison between the effects of a tetanus and the effects of sympathomimetic amines on fast- and slow-contracting mammalian muscles, *Brit. J. Pharmacol. Chemother.*, 19, 464-484.
- Bowman, W.C. and Nott, M.W. (1969). Actions of sympathomimetic amines and their antagonists on skeletal muscle. *Pharmacol. Rev.* 21, 27-72.
- Bowman, W.C. and Rand, M.J. (1961) Actions of Triethylcholine on neuromuscular transmission. *Brit. J. Pharmacol. Chemother.*, 17, 176-195.
- Bowman, W.C. and Raper, C. (1966). Effects of sympathomimetic amines on neuromuscular transmission, *Brit. J. Pharmacol. Chemother.*, 27, 313-331.
- Bowman, W.C. and Raper, C. (1967). Adrenotropic receptors in skeletal muscle, *Ann. N.Y. Acad. Sci.*, 139, 741-753.
- Bowman, W.C. and Zaimis, E. (1956). The similarity in the response of skeletal, smooth and cardiac muscle to sympathomimetic amines, Communication to January Meeting of British Pharmacological Society.

- Bowman, W.C. and Zaimis, E. (1958). The effects of adrenaline, nor-adrenaline, and isoprenaline on skeletal muscle contractions in the cat, *J. Physiol. (London)*, 144, 92-107.
- Boyd, I.A. (1956). The tenuissimus muscle of the cat, *J. Physiol. (London)*, 133, 35-36P.
- Boyd, I.A. and Martin, A.R. (1955). The quantal composition of the mammalian endplate potential, *J. Physiol. (London)*, 129, 14-15P.
- Boyd, I.A. and Martin, A.R. (1956a). Spontaneous subthreshold activity at mammalian neuromuscular junctions, *J. Physiol. (London)*, 132, 61-73.
- Boyd, I.A. and Martin, A.R. (1956b). The endplate potential in mammalian muscle, *J. Physiol. (London)*, 132, 74-91.
- Boyd, I.A. and Martin, A.R. (1959). Membrane constants of mammalian muscle fibers, *J. Physiol. (London)*, 147, 450-457.
- Breckenridge, B. McL., Burn, J.H. and Matschinsky, F.M. (1967). Theophylline, epinephrine, and neostigmine facilitation of neuromuscular transmission, *Proc. Nat. Acad. Sci.*, 57, 1893-1897.
- Brooks, V.B. (1956). An intracellular study of the action of repetitive nerve volleys and of botulinum toxin in miniature endplate potentials, *J. Physiol. (London)*, 134, 264-277.
- Brown, Byron, Wm., (1962). Estimation of the mean number of quanta per endplate potential, *J. Pharmacol. Exp. Ther.*, 138, 327-328.
- Brown, G. L. (1938). The preparation of the tibialis anterior muscle (cat) for close arterial injections, *J. Physiol. (London)*, 92, 22-23P.
- Brown, G. L., Bulbring, E. and Burns, B. D. (1948). The action of epinephrine on mammalian skeletal muscle, *J. Physiol. (London)*, 107, 115-128.

- Brown, G. L., Dale, H.H., and Feldberg, W.J. (1936). Reactions of the normal mammalian muscle to acetylcholine and to eserine, *J. Physiol. (London)*, 87, 394-424.
- Brown, G. L., Goffart, M. and Vianna, Dias, M. (1950). The effects of epinephrine and sympathetic stimulation on the demarcation potential of mammalian skeletal muscle, *J. Physiol. (London)*, 111, 184-194.
- Brown, T. Graham, (1913). Tenuissimus muscle of cat in situ twitch response, *Proc. Roy. Soc. London B.*, 87, 132-144.
- Bulbring, E. and Burn, J.H. (1940). The effect of sympathomimetic amines and other substances on the contraction of skeletal muscle, *J. Pharmacol. Exp. Ther.*, 68, 150-172.
- Bulbring, E. and Burn, J.H. (1942). The interrelation of prostigmine, adrenaline and ephedrine in skeletal muscle, *J. Physiol. (London)*, 101, 224-235.
- Buller, A.J., Eccles, J.C. and Eccles, R.M. (1960). Differentiation of fast and slow muscles in the cat hind limb, *J. Physiol. (London)*, 150, 399-416.
- Burke, W. (1957). Spontaneous potentials in slow muscle fibers of the frog, *J. Physiol. (London)*, 135, 511-521.
- Changeux, J.P., Kasai, M., Lee, C.Y. (1970). Use of snake venom toxin to characterize the cholinergic receptor protein, *Proc. Nat. Acad. Sci.*, 67, 1241-1247.
- Christ, D.D. and Blaber, L.C. (1968). The actions of benzoquinonium in the isolated cat tenuissimus muscle, *J. Pharmacol. Exp. Ther.*, 160, 159-165.
- Christ, D.D. and Nishi, S. (1971). Site of adrenaline blockade in the superior cervical ganglion of the rabbit, *J. Physiol. (London)*, 213, 107-117.
- Ciani, S. and Edwards, C. (1963). The effect of acetylcholine on neuromuscular transmission in the frog, *J. Pharmacol. Exp. Ther.*, 142, 21-23.

- Coers, C. (1955). Les variations structurelles normales et pathologiques de la jonction neuromusculaire, *Acta Neurol. Belg.*, 55, 741-866.
- Coers, C. and Woolf, A. L., The Innervation of Muscles, Charles C. Thomas, Springfield, Ill., (1959).
- Cole, K.S. (1961). An analysis of the membrane potential along a clamped squid axon, *Biophys. J.*, 1, 401-418.
- Collier, B. (1969). The preferential release of newly synthesized transmitter by a sympathetic ganglion, *J. Physiol. (London)*, 205, 341-369.
- Collier, B. and MacIntosh, F.C. (1969). The source of choline for acetylcholine synthesis in a sympathetic ganglion, *Canad. J. Physiol. Pharmacol.*, 47, 127-135.
- Colomo, F. and Rahaminoff, R. (1968). Interaction between sodium and calcium ions in the process of transmitter release at the neuromuscular junction, *J. Physiol. (London)*, 198, 203-218.
- Cooper, S. (1929). The relation of active to inactive fibers in fractional contraction of muscle, *J. Physiol. (London)*, 67, 1-13.
- Coppee, G. (1943). La transmission neuromusculaire: curarisation, decurarisation et reinforcement a la jonction myoneurale, *Arch. Int. Physiol.*, 53, 327-507.
- Cori, C.F. (1931). Mammalian carbohydrate metabolism, *Physiol. Rev.*, 11, 143-275.
- Couteaux, R. (1958). Morphological and cytochemical observations on the post-synaptic membrane at motor endplates and ganglionic synapses, *Exp. Cell Res.*, Suppl. 5, 294-322.
- Crouch, J.E., Text-atlas of Cat Anatomy, Lea and Febiger, Philadelphia, (1969).
- Csilik, B. Functional structure of the post-synaptic membrane in the myoneural junction, Akademiai Kiada, Budapest, pg. 41, (1967).

- Curtis, D.R. and Eccles, J.C. (1960). Synaptic action during and after repetitive stimulation, *J. Physiol. (London)*, 150, 374-398.
- Dakin, H.D. (1905). On the physiological activity of substances indirectly related to adrenaline, *Proc. Roy. Soc. London B.*, 76, 498-503.
- Dale, H.H. and Dudley, H.W. (1929). The presence of histamine and acetylcholine in the spleen of the ox and the horse, *J. Physiol. (London)*, 68, 97-123.
- Dale, H.H. (1914). The action of certain esters and ethers of choline and their relation to muscarine, *J. Pharmacol. Exp. Ther.*, 6, 147-190.
- Dale, H.H., Feldberg, W. and Vogt, M. (1936). Release of acetylcholine at voluntary motor nerve endings, *J. Physiol. (London)*, 86, 353-380.
- deGroat, W.C. and Volle, R.L. (1965). Ganglionic actions of catecholamines, *Pharmacologist*, 7, 158.
- deHarven, E. and Coers, C. (1959). Electron microscopic study of the human neuromuscular junction, *J. Biophys. Biochem. Cytol.*, 6, 7-10.
- del Castillo, J. and Engback, L. (1954). The nature of neuromuscular block produced by magnesium, *J. Physiol. (London)*, 124, 370-384.
- del Castillo, J. and Katz, B. (1954a). Quantal components of the endplate potential, *J. Physiol. (London)*, 124, 560-573.
- del Castillo, J. and Katz, B. (1954b). Statistical factors involved in neuromuscular facilitation and depression, *J. Physiol. (London)*, 124, 574-585.
- del Castillo, J. and Katz, B. (1954c). Changes in endplate activity produced by presynaptic polarization, *J. Physiol. (London)*, 124, 586-604.

- del Castillo, J. and Katz, B. (1957). A study of curare action with an electrical micro method, Proc. Roy. Soc. London B., 146, 339-356.
- del Castillo, J. and Stark, L. (1952). The effect of calcium ions on the motor endplate potentials, J. Physiol. (London), 116, 507-515.
- Denny-Brown, D.E. (1929). The histological features of striped muscle in relation to its functional activity, Proc. Roy. Soc. London B., 104, 371-411.
- de Robertis, E. (1958). Submicroscopic morphology and function of the synapse, Exp. Cell Res. Suppl. 5, 347-369.
- de Robertis, E. (1971). Molecular biology of synaptic receptors, Science, 171, 963-971.
- de Robertis, E. and Bennett, H.S. (1955). Some features of the submicroscopic morphology of synapses in frog and earthworm J. Biophys. Biochem. Cytol., 1, 47-58.
- Desmedt, J.E. (1966). Presynaptic mechanisms in myasthenia gravis, Ann. N.Y. Acad. Sci., 135, 209-246.
- Dodge, F.A.Jr. and Rahaminoff, R. (1967). On the relationship between calcium ion concentration and the amplitude of the endplate potential, J. Physiol. (London), 189, 90-91P.
- Dodge, F.A.Jr. and Rahaminoff, R. (1967). Co-operative action of calcium ion in transmitter release at the neuromuscular junction, J. Physiol. (London), 193, 419-432.
- Dubin, H.E. (1925). The effect of L-suprarenin (synthetic epinephrine) and various derivatives upon the blood sugar of normal animals, J. Pharmacol. Exp. Ther., 26, 233-241.
- Dudel, J. and Kuffler, S.W. (1961). The quantal nature of transmission and spontaneous miniature potentials at the crayfish neuromuscular junction, J. Physiol. (London), 155, 514-529.
- Eccles, J.C., The Physiology of Synapses, Springer-Verlag, Berlin; Academic Press Inc., New York, (1964).

- Edwards, C. and Ikeda, K. (1962). Effects of 2-PAM and succinylcholine in neuromuscular transmission in the frog, *J. Pharmacol. Exp. Ther.*, 138, 322-328.
- Elliott, T.R. (1905). The action of adrenalin, *J. Physiol. (London)*, 32, 401-467.
- Ellis, S. (1958). Relation of biochemical effects of epinephrine to its muscular effects, *Pharmacol. Rev.*, 11, 469-479.
- Ellis, S. and Vincent, N.H. (1966). Effect of ionic alterations in epinephrine induced cardiac glycogenolysis and phosphorylase activation, *Pharmacologist*, 8, 185.
- Elmqvist, D., Johns, T.R. and Thesleff, S. (1960). A study of some electrophysiological properties of human intercostal muscle, *J. Physiol. (London)*, 154, 602-607.
- Elmqvist, D. and Quastel, D.M.J. (1965). A quantitative study of endplate potentials in isolated human muscle, *J. Physiol. (London)*, 178, 505-529.
- Emmelin, N. and MacIntosh, F.C. (1956). The release of acetylcholine from perfused sympathetic ganglia and skeletal muscle, *J. Physiol. (London)*, 131, 477-496.
- Fatt, P. and Katz, B. (1950). Some observations on biological noise, *Nature*, 166, 597-598.
- Fatt, P. and Katz, B. (1951). An analysis of the endplate potential recorded with an intracellular electrode, *J. Physiol. (London)*, 115, 320-370.
- Fatt, P. and Katz, B. (1952). Spontaneous subthreshold activity at motor nerve endings, *J. Physiol. (London)*, 117, 109-128.
- Feldman, D.S. (1965). Calcium dependence of spontaneous acetylcholine release at mammalian motor nerve terminals, *J. Physiol. (London)*, 179, 33-34P.
- Feng, T.P. (1936). Studies on the neuromuscular junction. I. The inhibition at the neuromuscular junction, *Chin. J. Physiol.*, 10, 417-434.

- Feng, T.P. (1936) Studies on the neuromuscular junction. II. The universal antagonism between calcium and curarizing agencies, *Chin. J. Physiol.*, 10, 513-528.
- Feng, T.P. and Li, T.H. (1941). Studies on the neuromuscular junction. XXIII. A new aspect of the phenomena of eserine potentiation and post-tentanic facilitation in mammalian muscles, *Chin. J. Physiol.*, 16, 37-56.
- Ferko, A.P. and Calesnick, B. (1971). L-DOPA and dopamine on skeletal muscle, *Res. Commun. Chem. Pathol. Pharmacol.*, 2, 146-153.
- Fiker, S. (1955). Paper chromatographic division of multivalent phenoles, *Chem. Abstr.*, 49, 3734.
- Folkow, B., Haggendal, J. and Lisander, B. (1968). Extent of release and elimination of noradrenaline at peripheral adrenergic nerve terminals, *Acta Physiol. Scand.*, 72, Suppl. 307, 6-38.
- Friedenwald, J.S. and Hermann, H. (1942). Inactivation of amine oxidase by enzymatic oxidative products of catechol and adrenalin, *J. Biol. Chem.*, 146, 411-419.
- Furshpan, E.J. (1956). The effects of osmotic pressure changes on the spontaneous activity of motor nerve endings, *J. Physiol. (London)*, 134, 689-697.
- Gage, P.W. and Hubbard, J.I. (1965). Evidence for a Poisson distribution of mepps and some implications, *Nature*, 208, 395-396.
- Gage, P.W. and Quastel, D.M.J. (1966). Competition between sodium and calcium ions in transmitter release at a mammalian neuromuscular junction, *J. Physiol. (Nature)*, 185, 95-123.
- Gatgounis, J. and Walton, R.P. (1958). Cerebral site of action of compounds with conspicuous pressor and inotropic effects, *Fed. Proc.*, 17, 370.
- Gatgounis, J. and Walton, R.P. (1960). Resorcinol isomers and metrazole; their centrally mediated sympathetic circulatory effects, *J. Pharmacol. Exp. Ther.*, 128, 363-371.

- Goffart, M. and Holmes, O. (1962). The effects of adrenaline on mammalian "C" and "A" nerve fibers, *J. Physiol. (London)*, 162, 18-19P.
- Goffart, M. and Ritchie, J.M. (1952). The effect of epinephrine on the contraction of mammalian skeletal muscle, *Amer. J. Physiol.*, 34, 89-96.
- Goldberg, A.L. and Singer, J.J. (1969). Evidence for a role of Cyclic-AMP in neuromuscular transmission, *Proc. Nat. Acad. Sci.*, 64, 134-141.
- Goldstein, Avram, Biostatistics: An Introductory Text, The Macmillan Company, New York, (1969).
- Goodman, L.S. and Gilman A. (Edits) The Pharmacological Basis of Therapeutics, 4th Edition, The Macmillan Company, New York, (1970).
- Graham, J. and Gerard, R.W. (1946). Membrane potentials and excitation of impaled single muscle fibers, *J. Cell. Comp. Physiol.*, 28, 99-117.
- Grob, D., Johns, R.J. and Harvey, A.M. (1956). Studies in neuromuscular functions. IV. Stimulating and depressant effects of acetylcholine and choline in patients with myasthenia gravis, and their relationship to the defect in neuromuscular transmission, *Bull. Johns Hopkins Hosp.*, 99, 153-181.
- Gruber, C.M. (1914). Studies in fatigue. IV. The relation of adrenalin to curare and fatigue in normal and denervated muscles, *Amer. J. Physiol.*, 34, 89-96.
- Harold, C.H., Nierenstein, M. and Roaf, H.E. (1911). The influence of the presence and position of the various radicles of adrenalin on its physiological activity, *J. Physiol. (London)*, 41, 308-317.
- Harvey, A.M. (1939). Action of procaine on neuromuscular transmission, *Bull. Johns Hopkins Hosp.*, 65, 223-238.

- Harvey, A. M. and MacIntosh, F. C. (1940). Calcium ions and synaptic transmission in sympathetic ganglion, *J. Physiol.* (London), 97, 408-416.
- Hebb, C. O. and Waites, G. M. H. (1956). Choline acetylase in antero and retrograde degeneration of a cholinergic nerve, *J. Physiol.* (London), 132, 667-671.
- Hebb, C. O. and Smallman, B. N. (1956). Intracellular distribution of choline acetylase, *J. Physiol.* (London), 134, 385-392.
- Hobbiger, F. (1952). The mechanism of anti-curare action of certain neostigmine analogues, *Brit. J. Pharmacol. Chemother.*, 7, 223-236.
- Hodgkin, A. L. and Katz, B. (1949). The effect of sodium ions on the electrical activity of the giant squid axon of the squid, *J. Physiol.* (London), 108, 37-77.
- Hodgkin, A. L. (1950). Conduction of nervous impulse; some recent experiments, *Brit. Med. Bull.*, 6, 322-325.
- Hodgkin, A. L. (1951). The ionic basis of electrical activity in nerve and muscle, *Biol. Rev.*, 26, 339-409.
- Hodgkin, A. L. (1958). The Croonian Lecture. Ionic movements and electrical activity in giant nerve fibers, *Proc. Roy. Soc. (London), B.*, 148, 1-37.
- Hodgkin, A. L., The Conduction of the Nervous Impulse, Liverpool University Press, Liverpool (1967).
- Hodgkin, A. L. and Keynes, R. D. (1957). Movements of labelled calcium in squid giant axons, *J. Physiol.* (London), 138, 253-281.
- Hodgkin, A. L. and Horowitz, P. (1959). The influence of potassium and chloride ions on the membrane potential of single muscle fibers, *J. Physiol.* (London), 148, 127-160.
- Hofmann, W. W. (1969). Caffeine effects on transmitter depletion and mobilization at motor nerve terminals, *Amer. J. Physiol.*, 216, 621-629.

- Hoppe, J.O. (1951). A new series of synthetic curare-like compounds, *Ann. N.Y. Acad. Sci.*, 54, 395-406.
- Hubbard, J.I. (1961). The effect of calcium ion and magnesium ion on the spontaneous release of transmitter from mammalian motor nerve endings, *J. Physiol. (London)*, 159, 507-517.
- Hubbard, J.I. (1963). Repetitive stimulation at the mammalian neuro-muscular junction, and the mobilization of transmitter, *J. Physiol. (London)*, 169, 641-662.
- Hubbard, J.I., Jones, S.F. and Landau, E.M. (1967). The relationship between the state of nerve terminal polarization and liberization of acetylcholine, *Ann. N.Y. Acad. Sci.*, 144, 459-469.
- Hubbard, J.I., Jones, S.F. and Landau, E.M. (1968). On the mechanism by which calcium ions and magnesium ions affect the spontaneous release of transmitter from mammalian motor nerve terminals, *J. Physiol. (London)*, 194, 355-380.
- Hubbard, J.I., Jones, S.F., and Landau, E.M. (1968). An examination of the effects of osmotic pressure changes upon transmitter release from mammalian motor nerve terminals, *J. Physiol. (London)*, 197, 639-657.
- Hubbard, J.I. and Kwanbunbumpen, S. (1968). Evidence for the vesicle hypothesis, *J. Physiol. (London)*, 194, 407-420.
- Hubbard, J.I., Llinás, R. and Quastel, D.M.J. Electrophysiological Analysis of Synaptic Transmission, Williams and Wilkins, Co., Baltimore, Md., (1969).
- Hubbard, J.I. and Schmidt, R.F. (1963). An electrophysiological investigation of mammalian motor nerve terminals, *J. Physiol. (London)*, 166, 145-167.
- Hubbard, J.I., Schmidt, R.F. and Yokota, T. (1965). The affect of acetylcholine upon mammalian motor nerve terminals, *J. Physiol. (London)*, 181, 810-820.
- Hubbard, J.I. and Willis, W.D. (1962). Hyperpolarization of mammalian motor nerve terminals, *J. Physiol. (London)*, 163, 115-137.

- Hubbard, J.I. and Willis, W.D. (1962). Reduction of transmitter output by depolarization, *Nature*, 193, 1294-1295.
- Hubbard, J.I., Wilson, D.F. and Miyamoto, M. (1969). Reduction of transmitter release by d-tubocurarine, *Nature*, 223, 531-533.
- Hunt, R. and Taveau, R. deM. (1906). On the physiologic action of certain choline derivatives and new methods for detecting choline, *Brit. Med. J.*, 2, 1788-1791.
- Hutter, O.F. and Kostial, K. (1954). Effect of magnesium and calcium ions on the release of acetylcholine, *J. Physiol. (London)*, 124, 234-241.
- Hutter, O.F. and Loewenstein, W.R. (1955). Nature of neuromuscular facilitation by sympathetic stimulation in the frog, *J. Physiol. (London)*, 130, 559-571.
- Jenkinson, D.H., Stamenovic, B.A. and Whitaker, B.D.L. (1968). The effect of noradrenaline on the endplate potential in twitch fibers of the frog, *J. Physiol. (London)*, 195, 743-754.
- Johnson, E.S. (1962). The spasmolytic actions of pyrogallol and catechol on the isolated guinea pig ileum, *J. Pharm. Pharmacol.*, 14, 272-279.
- Karczmar, A.G. Pharmacologic effects of newer bisquaternary anticholinesterases, particularly at the neuromyal junction. In: Bioelectrogenesis, Edit. C. Chagas and A. P. de Carvalho, Elsevier Publishing Co., Amsterdam, pp. 320-340, 1961.
- Karczmar, A.G. (1967a) Neuromuscular Pharmacology, *Annu. Rev. Pharmacol.*, 7, 241-276.
- Karczmar, A.G., Pharmacologic, toxicologic and therapeutic properties of anticholinesterase agents, In: Physiological Pharmacology Edit. W.S. Root and F.G. Hofmann, Volume 3, Academic Press, New York, pp. 164-322, (1967b).

- Karczmar, A. G. Introduction: History of the research with anticholinesterase agents. In: Anticholinesterase Agents, Edit. A. G. Karczmar. Pergamon Press, London-New York, Vol. I., pp. 1-44, (1970).
- Karczmar, A. G., Nishi, S. and Blaber, L. C. (1970). Investigations, particularly by means of anticholinesterase agents, of the multiple, peripheral and central cholinergic mechanisms and of their behavioral implications, *Acta Vitaminologica Et Enzymologica*, 24, 131-189.
- Karczmar, A. G. and Nishi, S. The types and sites of cholinergic receptors, In: Advances in Cytopharmacology, Edit. F. Clementi and B. Ceccarelli, Vol. I, pp. 301-318, 1971.
- Katz, B. (1958) Microphysiology of the neuro-muscular junction, *Bull. Johns Hopkins Hosp.*, 102, 275-312.
- Katz, B. (1962) The transmission of impulses from nerve to muscle, and the subcellular unit of synaptic action, *Proc. Roy. Soc. London B.*, 155, 455-477.
- Katz, B., Nerve, Muscle and Synapse, McGraw-Hill, New York, (1966).
- Katz, B. and Miledi, R. (1964). Localization of calcium ion action at the nerve muscle junction, *J. Physiol. (London)*, 171, 10-12P.
- Katz, B. and Miledi, R. (1965). The effect of calcium on acetylcholine and release from motor nerve endings, *Proc. Roy. Soc. London B.*, 161, 496-503.
- Katz, B. and Miledi, R. (1967a). The timing of calcium ion action during neuromuscular transmission, *J. Physiol. (London)*, 189, 535-544.
- Katz, B. and Miledi, R. (1967b). A study of synaptic transmission in the absence of nerve impulses, *J. Physiol. (London)*, 192, 407-436.

- Katz, B. and Miledi, R. (1967c). Ionic requirements of synaptic transmitter release, *Nature*, 215, 651.
- Katz, B. and Thesleff, S. (1957). On the factors which determine the amplitude of the "mepp", *J. Physiol. (London)*, 137, 267-278.
- Kelly, J.A. (1965). Antagonism between sodium ion and calcium ion at the neuromuscular junction, *Nature*, 205, 296-297.
- Kim, K.C. and Karczmar, A.G. (1967). Adaptation of the neuromuscular junction to constant concentration of acetylcholine, *Int. J. Neuropharmacol.*, 6, 51-61.
- King, Harold (1935). Curare alkaloids. Part I. Tubocurarine., *J. Chem. Soc.*, II, 1381-1389.
- Koelle, G.B. (1962). A new concept of the neurohumoral functions of acetylcholine and acetylcholinesterase, *J. Pharm. Pharmacol.*, 14, 65-90.
- Koelle, G.B. (1963). Cytological distributions and physiological functions of cholinesterase, *Hanb. Exp. Pharm.*, Suppl. 15, 178-298.
- Koelle, G.B. and Friedenwald, J.S. (1949). A histochemical method for localizing cholinesterase activity, *Proc. Soc. Exptl. Biol. Med.*, 70, 617-622.
- Koelle, G.B. and Steiner, E.C. (1956). The cerebral distribution of a tertiary and a quaternary anticholinesterase agent following intravenous and intraventricular injection, *J. Pharmacol. Exp. Ther.*, 118, 420-434.
- Kordas, M. (1968). The effect of atropine and curarine on the time course of the endplate potential in frog sartorius muscle, *Int. J. Neuropharmacol.*, 7, 523-530.
- Krebs, H.A. and Henseleit, K. (1932). Untersuchungen über die harnstoffbildung im tierkörper, *Z. Physiol. Chem. (Hoppe-Seyler's)* 210, 33-66.
- Krnjevic, K. and Miledi, R. (1958a). Failure of neuromuscular propagation in rats, *J. Physiol. (London)*, 140, 440-461.

- Krnjevic, K. and Miledi, R. (1958b). Some effects produced by adrenaline upon neuromuscular propagation in rats, *J. Physiol.* (London), 141, 291-304.
- Kuba, Kenji, (1969). The action of phenol on neuromuscular transmission in the red muscle of the fish, *Jap. J. Physiol.*, 19, 762-774.
- Kuba, K. (1970). Effects of catecholamines on the neuromuscular junction of the rat diaphragm, *J. Physiol.* (London), 211, 551-570.
- Kuno, M. (1964). Quantal components of excitatory post-synaptic potentials in spinal motoneurons, *J. Physiol.* (London), 175, 81-99.
- Kuperman, A.S., Gill, E.W. and Riker, W.F. (1961). The relationship between cholinesterase inhibition and drug induced facilitation of mammalian neuromuscular transmission, *J. Pharmacol. Exp. Ther.*, 132, 65-73.
- LaBrosse, E.H. and Axelrod, J. and Kety, S.S. (1958). O-methylation, the principal route of metabolism of epinephrine in man, *Science*, 128, 593-594.
- Libet, B. (1970). Generation of slow inhibitory and excitatory postsynaptic potentials, *Fed. Proc.*, 29, 1945-1956.
- Liddell, E.G.T. and Sherrington, C. (1924-25). Recruitment and some other features of reflex inhibition, *Proc. Roy. Soc. London B.*, 97, 488-518.
- Liley, A.W. (1956a). An investigation of spontaneous activity at the neuromuscular junction of the rat, *J. Physiol.* (London), 132, 650-666.
- Liley, A.W. (1956b). The quantal components of the mammalian endplate potential, *J. Physiol.* (London), 133, 571-587.
- Liley, A.W. (1956c). The effect of presynaptic polarization on the spontaneous activity at the mammalian neuromuscular junction, *J. Physiol.* (London), 134, 427-443.

- Liley, A.W. and North, K.A.K. (1953). An electrical investigation of effects of repetitive stimulation on mammalian neuromuscular junction, *J. Neurophysiol.*, 16, 509-527.
- Lister, Joseph, (1867). On the antiseptic principle in the practice of surgery, *Lancet*, 2, 353-356.
- Loewi, O. (1921). Uber humorale uber tragbarkeit der herznervenwirkung. X. Mitteilung. Uber das schicksal des vagusstoffs, *Pfluegers Arch. Gesamte Physiol menshen tiere*, 214, 678-688.
- Long, J.P. and Schueler, F.W. (1954). A new series of cholinesterase inhibitors, *J. Amer. Pharm. Assn. Sci. Ed.*, 43, 79-86.
- Lundberg, A. and Quilisch, H. (1953). On the effect of calcium ion on presynaptic potentiation and depression at the neuromuscular junction, *Acta Physiol. Scand.*, 30, Suppl. III, 121-129.
- Maclagen, J. (1962). A comparison of the responses of the tenuissimus muscle to neuromuscular blocking drugs in vivo and in vitro, *Brit. J. Pharmacol. Chemother.*, 18, 204-216.
- Maddock, W.O., Rankin, V.M. and Youmans, W.B. (1948). Prevention of the anti-curare action of epinephrine by dibenamine, *Proc. Soc. Exp. Biol. Med.*, 67, 151-153.
- Mann, P.J.G., Tennenbaum, M. and Quastel, J.H. (1938). On the mechanism of acetylcholine formation in brain in vitro, *Biochem. J.*, 32, 243-261.
- Martin, A.R. (1955). A further study of the statistical composition of the endplate potential, *J. Physiol. (London)*, 130, 114-122.
- Martin, A.R. (1966). Quantal nature of synaptic transmission, *Physiol. Rev.*, 46, 51-66.

- Masland, R.L. and Wigton, R.S. (1940). Nerve activity accompanying fasciculation produced by prostigmine, *J. Neurophysiol.*, 3, 269-275.
- Matsumoto, J., Kiyono, S., Nishi, H., Koike, J. and Ichihashi, T. (1963). The convulsive mechanism of phenol derivatives, *Med. J. Osaka Univ.*, 13, 313-323.
- Matsumoto, J. and Nishi, H. (1963a). Functional mechanism of catechol in the central nervous system. I. The anatomic site of action, *Med. J. Osaka Univ.*, 13, 365-373.
- Matsumoto, J. and Nishi, H. (1963b). Functional mechanism of catechol in the central nervous system. II. The physiochemical site of action, *Med. J. Osaka Univ.*, 13, 375-386.
- Miledi, R., Molinoff, P. and Potter, L.T. (1971). Isolation of the cholinergic receptor protein of torpedo electric tissue, *Nature*, 229, 554-557.
- Mizuno, T. (1934). Uber die wirkung der phenole auf die muskelzuckungen, *Jap. J. Med. Sci. Biophysics*, 3, 56-58.
- Mogey, G.A. and Young, P.A. (1949). The antagonism of curarizing activity by phenolic substances, *Brit. J. Pharmacol. Chemother.*, 4, 359-365.
- Muhlmann, M. (1896). Zur physiologie der nebenniere, *Deut. Med. Wochenschr.*, 22, 409-412.
- Mulinos, M.G. and Osborne, R.L. (1935a). A note on the analysis of sympathicomimetic action, *Proc. Soc. Exp. Biol. Med.*, 33, 458.
- Mulinos, M.G. and Osborne, R.L. (1935b). Physiological activity of some catechol derivatives, *Proc. Soc. Exp. Biol. Med.* 32, 1344-1346.

- Nachmansohn, D., The neuromuscular junction. In: The Structure and Function of Muscle, Edit. G.H. Bourne, Vol. 2, Academic Press, New York and London, pp. 199-295, (1960)
- Naess, K. and Sirnes, T. (1953). A synergistic effect of epinephrine and d-tubocurarine on the neuromuscular transmission, Acta Physiol. Scand., 29, 293-306.
- Nishi, S. and Koketsu, K. (1960). Electrical properties and activities of single sympathetic neurons in frogs, J. Cell. Comp. Physiol., 55, 15-30.
- Okamoto, M. and Riker, W.F. Jr. (1969). Subacute denervation: a means of disclosing mammalian motor nerve terminals as critical sites of acetylcholine and facilitatory drug actions, J. Pharmacol. Exp. Ther., 166, 217-224.
- Oliver, G. and Schafer, E.A. (1895). The physiological effects of suprarenal capsules, J. Physiol. (London), 18, 230-276.
- Osborne, R.L. (1937). Studies in sympathetomimicity; physiologic effects of more non-amino catechol derivatives, Proc. Soc. Exper. Biol. Med., 35, 567-570.
- Otsuka, M. and Endo, M. (1960a). The effect of guanidine on neuromuscular transmission, J. Pharmacol. Exp. Ther., 128, 273-282.
- Otsuka, M. and Endo, M. (1960b). Presynaptic nature of neuromuscular depression in the frog, Nature, 188, 501-502.
- Otsuka, M., Endo, M. and Nonomura, Y. (1962). Pre-synaptic nature of neuromuscular depression, Jap. J. Physiol., 12, 537-584.
- Otsuka, M. and Nonomura, Y. (1963). The action of phenolic substances on motor nerve endings, J. Pharmacol. Exp. Ther., 140, 41-45.

- Palade, G. E. and Palay, S. L. (1954). Electron microscope observations on interneuronal and neuromuscular synapses, *Anat. Rec.*, 118, 335-336.
- Palay, S. L. (1958). The morphology of synapses in the central nervous system, *Exp. Cell Res. Suppl.*, 5, 275-293.
- Panella, A. (1907). Action du principe actif surrenal sur la fatigue musculaire, *Arch. Ital. Biol.*, 48, 430-463.
- Perry, W. L. (1953). Acetylcholine release in the cat's superior cervical ganglion, *J. Physiol. (London)*, 119, 439-454.
- Pilar, G. (1969). Effect of acetylcholine on pre- and post-synaptic elements of avian ciliary ganglion synapses, *Fed. Proc.*, 28, 670.
- Porter, E. L. and Hart, V. W. (1923). Reflex contractions of an all-or-none character in the spinal cat, *Amer. J. Physiol.*, 66, 391-403.
- Potter, L. T. (1968). Turnover of acetylcholine-¹⁴C in rat hemidiaphragms. *Proc. Physiol. Soc.*, 13-14th Dec., 3-5P.
- Reger, J. F. (1954). Electron microscopy of the motor end-plate in intercostal muscle of the rat. *Anat. Rec.*, 118, 344.
- Reger, J. F. (1957). The ultrastructure of normal and denervated neuromuscular synapses in mouse gastrocnemius muscle, *Exp. Cell Res.*, 12, 662-665.
- Remen, L. (1932). Zur pathogenese und therapie der myasthenia gravis pseudoparalytic, *Dt. Z. Nerv. Heilk.*, 128, 66-78.
- Riker, W. F. Jr. (1953). Excitatory and anti-curare properties of acetylcholine and related quaternary ammonium compounds at the neuromuscular junction, *Pharmacol. Rev.*, 5, 1-86.

- Riker, W.F.Jr. (1960). Pharmacologic considerations in a re-evaluation of the neuromuscular synapses, *Arch. Neurol.*, 3, 488-499.
- Riker, W.F.Jr. (1966). The actions of acetylcholine on mammalian motor nerve terminals, *J. Pharm. Pharmacol.*, 152, 397-416.
- Riker, W.F.Jr. (1969). Pharmacology of motor nerve terminals, *Annu. Rev. Pharmacol.*, 9, 173-208.
- Riker, W.F.Jr., J. Standaert, F.G. and Fujimori, H. (1957). The motor nerve terminal as the primary focus for drug-induced facilitation of neuromuscular transmission, *J. Pharmacol. Exp. Ther.*, 121, 286-312.
- Riker, W.F.Jr. and Standaert, F.G. (1966). The action of facilitatory drugs and acetylcholine on neuromuscular transmission, *Ann. N.Y. Acad. Sci.*, 135, 163-176.
- Robertson, J.D. (1954). Electron microscope observations on a reptilian myoneural junction, *Anat. Rec.*, 118, 346.
- Robertson, J.D. (1956). The ultrastructure of the reptilian myoneural junction, *J. Biophys. Biochem. Cytol.*, 2, 381-394.
- Robertson, J.D. (1960). Electronmicroscopy of the motor endplate and the neuromuscular spindle, *Am.J. Phys. Med.*, 39, 1-43.
- Robison, G.A. Butcher, R.W. and Sutherland, E.W. (1967). Adenyl cyclase as an adrenergic receptor, *Ann.N.Y. Acad. Sci.*, 139, 703-723.
- Rogers, K.J., Angel, A. and Butterfield, L. (1968). The penetration of catechol and pyrogallol into mouse brain and the effect on cerebral monoamine levels, *J. Pharm. Pharmacol.*, 20, 727-729.
- Rothberger, C.J. (1902). Weitere mittheilungen uber antagonisten des curarins, *Pfluegers Arch. Gesamte Physiol. menschen tiere*, 92, 398-450.
- Shuster, Louis (Edit.), Readings in Pharmacology, Little, Brown and Company, Boston, (1962).

- Sherrington, C.S. (1910). Flexion-reflex of the limb, crossed extension reflex, and reflex stepping and standing, *J. Physiol.* (London), 40, 28-121.
- Sherrington, C.S. (1921). Break-shock reflexes and "supramaximal" contraction response of mammalian nerve muscle to single shock stimuli, *Proc. Roy. Soc. London B.*, 92, 245-258.
- Sjostrand, N. (1960). The effect of catechol on the isolated guinea pig ileum, *Acta Physiol. Scand.*, 49, 57-61.
- Sjostrand, N. (1961). Further studies on the effect of catechol on the isolated guinea pig ileum, *Acta Physiol. Scand.*, 52, 343-349.
- Standaert, F.G. and Roberts, J. (1967). A neural action of pronethalol, *Ann. N.Y. Acad. Sci.*, 139, 815-820.
- Stajrne, L., Hedqvist, P. and Bygdeman, S. (1969). Neurotransmitter quantum released from sympathetic nerves in cat skeletal muscle, *Life Sci.*, Oxford, 8, 189-197.
- Sutherland, E.W. and Robison, G.A. (1966). The role of cyclic-3', 5'-AMP in response to catecholamines and other hormones, *Pharmacol. Rev.*, 18, 145-161.
- Tainter, M.L. (1930). Comparative actions of sympathomimetic compounds; catechol derivatives, *J. Pharmacol. Exp. Ther.*, 40, 43-64.
- Takagi, K. and Takayanagi, I. (1965). Effects of aromatic nitro compounds and phenol derivatives on the cholinergic nerve endings of smooth and skeletal muscle, *Arch. Int. Pharmacodyn.*, 155, 373-380.
- Takeuchi, A. (1959). Neuromuscular transmission of fish skeletal muscles investigated with intracellular microelectrodes, *J. Cell. Comp. Physiol.*, 54, 211-270.
- Takeuchi, N. (1963). Effects of calcium ion on the conductance change of the endplate potential membrane during the action of transmitter, *J. Physiol.* (London), 167, 141-155.

- Takeuchi, A. and Takeuchi, N. (1959). Active phase of frog's endplate potential, *J. Neurophysiol.*, 22, 395-411.
- Takeuchi, A. and Takeuchi, N. (1960). On the permeability of end-plate membrane during the action of transmitter, *J. Physiol. (London)*, 154, 52-67.
- Talbott, J.H. (Edit.) (1965). Peripheral phenol injections reduce spasticity, *J. Amer. Med. Assn.*, 193, No. 12, 31-33.
- Thesleff, S. (1955). Neuromuscular block caused by acetylcholine, *Nature*, 175, 594-595.
- Thesleff, S. (1960) Effects of motor innervation on the chemical sensitivity of skeletal muscle, *Physiol. Rev.*, 40, 734-752.
- Thesleff, S. and Quastel, D.M. (1965). Neuromuscular pharmacology, *Annu. Rev. Pharmacol.*, 5, 263-284.
- Todd, R.G. (Edit.), Extra Pharmacopoeia Martindale, 25th. Edition. The Pharmaceutical Press, London, pp. 1441-1442, (1967).
- Usubiaga, J.E. (1968). Neuromuscular effects of beta-adrenergic blockers and their interaction with skeletal muscle relaxants, *Anesthesiology*, 29, 484-492.
- vonEuler, U.S. and Lishajko, F. (1959). Excretion of catechol in human urine, *Nature*, 183, 1123.
- Walker, Mary, B. (1935). Case showing effect of prostigmine on myasthenia gravis, *Proc. Roy. Soc. Med.*, 28, 759-761.
- Walton, R.P., Walton, R.P.Jr., and Thompson, W.L. (1959). Inotropic activity of catechol isomers and a series of related compounds, *J. Pharmacol. Exp. Ther.*, 125, 202-207.
- Werner, G. (1960). Neuromuscular facilitation and antidromic discharges in motor nerves; their relation to activity in motor nerve terminals, *J. Neurophysiol.*, 23, 171-187.
- White, R.P., Sewell, H.H.Jr. and Rudolph, A.S. (1965). Drug induced dissociation between evoked reticular potentials and the EEG, *Electroencephalogr. Clin. Neurophysiol.*, 19, 16-24.

- Wilson, A. T. and Wright, S. (1937). Anti-curare action of potassium and other substances, *Quart. J. Exp. Physiol. Cog. Med. Sci.*, 26, 127-139.
- Wilson, C. O. and Gisvold, O., Textbook of Organic Medicinal and Pharmaceutical Chemistry, 4th Edition, Lippincott, Philadelphia, (1962).
- Wolf, S. M., Rowland, L. P., Schotland, D. L., McKinney, A. S., Hoefler, P. F. A., Aranow, H. Jr. (1966). Myasthenia as an autoimmune disease: clinical aspects, *Ann. N.Y. Acad. Sci.*, 135, 517-535.
- Wylie, D. W., Archer, S. and Arnold, A. (1960). Augmentation of pharmacological properties of catecholamines by O-methyl transferase inhibitors, *J. Pharmacol. Exp. Ther.*, 130, 239-244.
- Zacks, Sumner, I., The Motor End Plate, W. B. Saunders Co., Philadelphia, London, (1964).
- Zacks, S. I. and Blumberg, J. M. (1961). Observations on the fine structure of mouse and human neuromuscular junctions, *J. Biophys. Biochem. Cytol.*, 10, 517-528.
- Zaimis, E. J. (1953). Motor endplate differences as a determining factor in the mode of action of neuromuscular blocking substances, *J. Physiol. (London)*, 122, 238-251.

APPROVAL SHEET

The dissertation submitted by Joel P. Gallagher has been read and approved by a committee composed of Alexander H. Friedman, Ph.D., John I. Hubbard, D.M., Ph.D., Kenji Kuba, M.D., Ph.D., Syogoro Nishi, M.D., Ph.D., Yvo T. Oester, M.D., Ph.D. and Alexander G. Karczmar, M.D., Ph.D. (Chairman).

The final copies of the dissertation have been examined by the chairman of the examining committee and his signature which appears below verifies that all the necessary changes have been incorporated and that the dissertation is now given final approval with reference to content, form and mechanical accuracy.

The dissertation is therefore accepted in partial fulfillment of the requirements for the Degree of Doctor of Philosophy.

1/14/1972
Date

Alexander G. Karczmar,
Signature of Committee Chairman