



eCOMMONS

Loyola University Chicago
Loyola eCommons

Master's Theses

Theses and Dissertations

1969

The Metabolism of D-Glucaric Acid by *Aspergillus Niger*

Barbara L. Zakes
Loyola University Chicago

Recommended Citation

Zakes, Barbara L., "The Metabolism of D-Glucaric Acid by *Aspergillus Niger*" (1969). *Master's Theses*. Paper 2351.
http://ecommons.luc.edu/luc_theses/2351

This Thesis is brought to you for free and open access by the Theses and Dissertations at Loyola eCommons. It has been accepted for inclusion in Master's Theses by an authorized administrator of Loyola eCommons. For more information, please contact ecommons@luc.edu.



This work is licensed under a [Creative Commons Attribution-NonCommercial-No Derivative Works 3.0 License](https://creativecommons.org/licenses/by-nc-nd/3.0/).
Copyright © 1969 Barbara L. Zakes

THE METABOLISM OF D-GLUCARIC ACID

BY ASPERGILLUS NIGER

by

Barbara L. Zakes

Department of Microbiology

Stritch School of Medicine

A Thesis Submitted to the Faculty of the Graduate

School of Loyola University in Partial

Fulfillment of the Requirements

for the Degree of Master of

Science

June

1969

LIBRARY

LOYOLA UNIVERSITY MEDICAL CENTER

TABLE OF CONTENTS

<u>CHAPTER</u>	<u>PAGE</u>
I. Introduction.	1
II. Materials and Methods	6
Organism	6
Media.	6
Cell-Free Extracts	8
Analytical Methods	9
Enzyme Assays.	11
III. Results	15
IV. Discussion.	26
V. Summary	31
VI. Literature Cited.	32

LIST OF TABLES

<u>TABLE</u>		<u>PAGE</u>
1.	α -Keto Acid Production	21
2.	Pyruvic Acid Formation.	24
3.	α -Ketoglutaric Acid Formation.	25

LIST OF FIGURES

<u>FIGURE</u>		<u>PAGE</u>
1.	Pathway for Metabolism of D-Gluconate by the Glycerate Pathway in Enteric Bacteria	4
2.	Pathway for the Metabolism of D-Gluconate by the α -Ketoglutarate Pathway	5
3.	Scheme for the Reaction of the TBA Test	17

INTRODUCTION

D-Glucaric acid is the dicarboxylic acid analogue of D-glucose, formerly known as saccharic acid. While it is known to have been isolated from natural sources, it can be synthesized from the oxidation of glucuronic acid or from glucuronolactone.

As early as 1927, glucaric acid was isolated from a culture medium, in which it had been produced by Aspergillus niger growing on glucose as its sole carbon source. This occurrence was reported by Challenger, Subramonian, and Walker (1).

It had been demonstrated a year earlier, in 1926, by den Dooren de Jong (2), that a wide variety of bacterial species could grow utilizing glucaric acid as their sole carbon and energy source. Other investigators subsequently demonstrated the ability of certain bacterial species to metabolize glucaric acid. Such was the work done by Kay (3) in 1926 using Escherichia coli as the experimental organism, and that of Simon (4) in 1947 using Glostridium acetobutylicum. It is of interest to note that these various micro-organisms did not produce the same end-products as the result of their metabolism of glucaric acid. However, these studies did indicate that the products formed were two or three carbon intermediates of the same types as those produced when glucose is metabolized.

Although this information about the utilization of glucaric acid by various bacterial species was known, very little was known about the pathway(s) by which this sugar acid was metabolized.

Determination of the pathway was begun in 1958 when Blumenthal and Campbell (5) demonstrated the formation of pyruvic acid from glucaric acid in a ratio of 1:1 when E. coli was grown on a medium containing only glucarate as a carbon and energy source. It was further reported by Blumenthal (6) that the intermediate product in this breakdown was a keto-deoxy form of the hexaric acid. He had also isolated the enzyme, D-glucaric acid dehydrase, which brought about this dehydration. The dehydration was shown to occur at either of two sites in the molecule, resulting in both 2-keto-3-deoxy- and 4-deoxy-5-keto- glucaric acid, with the latter compound being the major product formed (a calculated 86 - 91%) (7).

Further research into the problem, using Escherichia coli as the experimental organism, demonstrated that two additional enzymes participate in the breakdown of D-glucaric acid to pyruvic acid and glyceric acid. These were identified as keto-deoxy-glucarate (KDG) aldolase and tartronate semialdehyde reductase. The KDG aldolase cleaves KDG to form pyruvic acid and tartronate semialdehyde (TAS). The TAS is then reduced by TAS reductase to glyceric acid. This same pathway, which will be referred to as the glycerate pathway, was also found in many related Enterobacteriaceae as their means for catabolizing glucaric acid (8). The entire pathway, as formulated by Blumenthal et al., is illustrated in Fig. 1.

A second pathway, the α -ketoglutarate pathway, for the metabolism of glucaric acid has been found to exist in Bacillus megaterium (9,10), and in pseudomonads (11). The KDG, formed by the dehydration of glucarate, is

probably dehydrated a second time to yield diketo adipic acid. This compound is decarboxylated to form α -ketoglutarate semialdehyde which is then oxidized to α -ketoglutaric acid. This pathway is illustrated in Fig. 2.

The present study involves this same problem, namely, the metabolism of D-glucaric acid, but is concerned with the metabolic pathway which is followed by the fungi, with Aspergillus niger being utilized as the experimental organism.

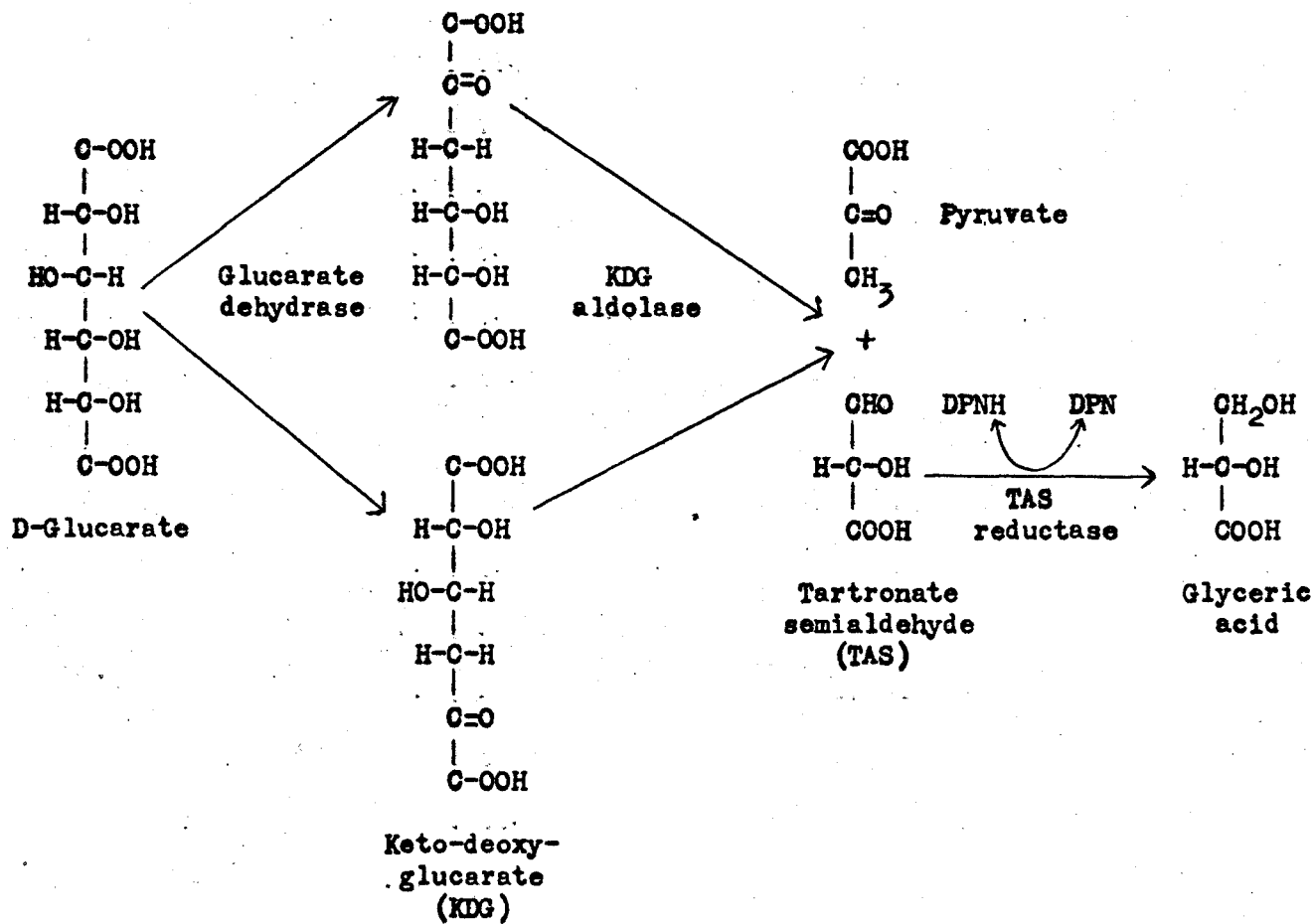

Figure 1

Pathway for metabolism of D-glucarate by the glycerate pathway in enteric bacteria.

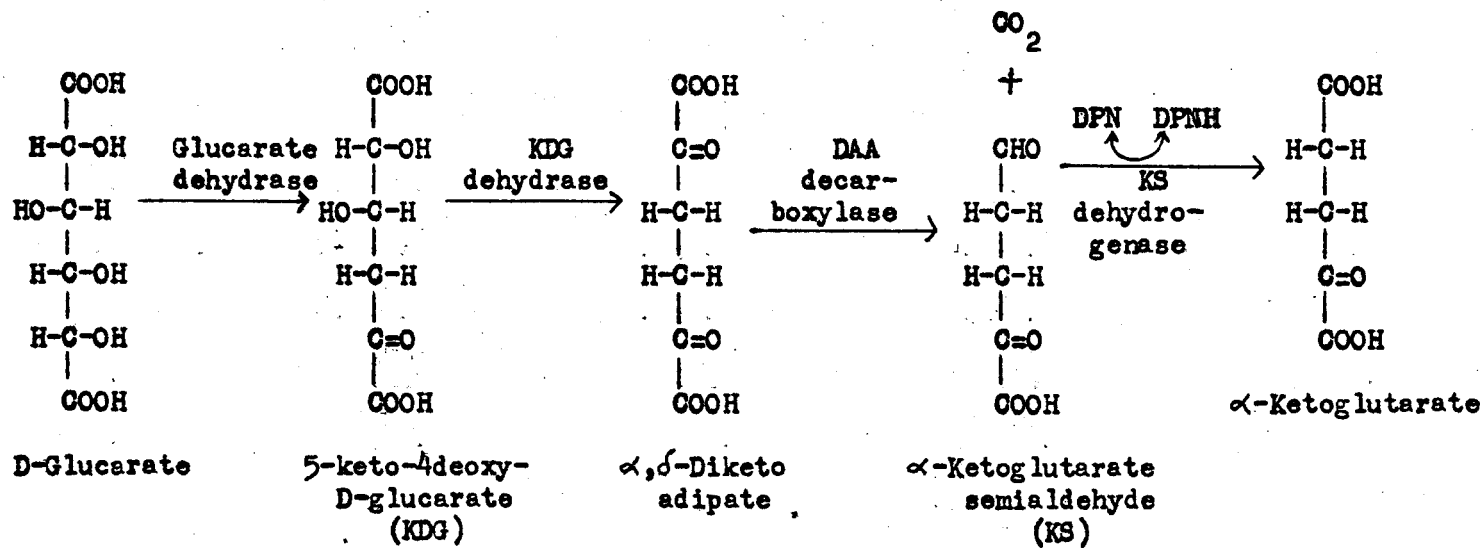

Figure 2

Pathway for the metabolism of D-glucarate by the α -ketoglutarate pathway.

MATERIALS AND METHODS

Organism. The experimental organism used in this project was the Ascomycete, Aspergillus niger. The culture was originally obtained from the American Type Culture Collection, Strain No. 6275, and was maintained as a stock culture for class study in the Loyola University Department of Microbiology. The culture was maintained on slants of Potato Dextrose Agar (Difco) and grown on the glucarate medium as a submerged, aerated culture.

Media. Since the purpose of the project was to determine the pathway by which A. niger metabolizes glucaric acid, a medium had to be defined in which the organism could grow using the glucarate as its only carbon and energy source. A solution of the required inorganic salts was prepared in the following proportions: 0.008% KH_2PO_4 , 0.03% NH_4NO_3 , 0.08% MgSO_4 , 0.00046% $\text{FeSO}_4 \cdot 7\text{H}_2\text{O}$, and 0.00046% $\text{ZnSO}_4 \cdot 2\text{H}_2\text{O}$. This was adapted from a medium reported by Bernhauer, Siebenäuger, and Tschinkel (12) when used by them in studies using A. niger. Although other salt solutions were tested, this one, after addition of the glucarate, was found to result in the best growth of A. niger, and so this was maintained as the standard inorganic salt solution. Twenty g of D-glucaric acid, prepared from Ca glucarate $\cdot 4 \text{H}_2\text{O}$ by deionization, were added per liter of salt solution to give a 2% concentration. The medium was then distributed in 50 ml aliquots into 250 ml Erlenmeyer flasks and autoclaved. The flasks of culture media were inoculated with spores of A. niger taken off slants of Potato Dextrose Agar, and placed on a rotary shaker at 30 C for four days. About 5 ml of sterile water were added to a

slant of A. niger that had been allowed to sporulate, the spores were scraped off with a loop, and a 1 ml sample was pipetted into each flask.

The original carbon source used was D-Glucaric (Saccharic) Acid Mono-Potassium Salt, obtained from Sigma Chemical Company. Because this was found in preliminary studies to contain impurities that reacted in the thiobarbituric acid test, it was decided upon to use a different form of glucarate as the carbon source in the medium. This source, which was then used consistently throughout the project, was calcium glucarate (saccharate) tetrahydrate C.P., obtained from Mann Research Laboratories, Inc., in New York. Since this calcium salt is insoluble in water, it was necessary to remove the calcium ions in order to obtain an aqueous solution of the glucarate. Five g of the calcium glucarate were added to 40 ml of Dowex - 50 W - X8 - H⁺ form, a cation exchange resin, and placed on a rotary shaker for about 2 hr. The deionized glucarate solution was then filtered out and the resin washed twice with deionized distilled water. The volume of the glucarate was brought up to 250 ml (a 2% solution). The pH of this solution, 2.8, was adjusted to pH 5.0 by addition of 1 N NaOH. The optimum pH for the growth of A. niger is 4.4 - 7.5 (13).

The presence of arsenite in a culture medium is known to hinder decarboxylation in cultures of A. niger, and thus an accumulation of α -keto acids would occur (14). In order to trap such intermediates which may be produced when glucarate is metabolized, cultures were grown in the usual manner: four days incubation on a rotary shaker at 30 C in the 2% glucarate

medium. The medium was then removed and replaced by a 50 ml aliquot of the 2% glucarate medium containing 0.01 M sodium arsenite (NaAsO_2). The cultures were replaced on the shaker at 30 C an additional two days, after which time the organism was removed by filtration and the filtrate was used for identification of α -keto acids present by chemical and enzymatic methods. Each flask contained about 2 g (wet weight) of cells.

Cell-free extracts. In order to test for the presence of the dehydrogenase within the cells, it was necessary to disrupt the cells and release the enzyme into solution. Two methods were used to obtain such cell-free extracts.

1. Grinding with glass beads. The culture medium was removed and the cells were washed with 0.05 M potassium phosphate buffer. The washed cells were ground in a chilled mortar for about 3 min with an equal weight of acid washed glass beads (Minnesota Mining and Manufacturing Co., Minneapolis, Type 113). The resulting paste was then washed into cold centrifuge tubes with the phosphate buffer (pH 5.7) and centrifuged in the cold at 12,000 X g for 15 min to remove the glass beads and cellular debris. The entire procedure was conducted at a temperature of 4 C.

2. Sonication. Washed cells were prepared in the same way as they had been for preparation of extracts by grinding. They were then suspended in 30 ml of 0.05 M potassium phosphate buffer, pH 5.7, and the entire suspension was placed in a continuous flow Rosett Cooling Cell. This container is designed to promote mixing of the material being insonated.

while maintaining the low temperature required. The cooling cell was immersed in a salt-ice-water cooling bath which remained at -4°C or below. This prevented the temperature of the suspension from rising above 4°C , thus minimizing denaturation of proteins. The cells were then disrupted by sonic oscillation for 10 min in a Branson Sonifier. Cellular debris was removed by centrifugation at 12,000 X g in a Serval SS-1 centrifuge in a cold room for 15 min at 4°C .

Analytical Methods. The concentration of protein present in the cell-free extract was determined spectrophotometrically according to the method of Waddell (15, 16). According to this procedure, the cell-free extract is diluted with 0.05 M potassium phosphate buffer so that it measures between an optical density of 1.5 and 0.5 when read at a setting of 215 nm, against a blank of the buffer solution. The absorbancy of the solution is then read at 225 nm. The difference in these two readings is then multiplied by 144, and the figure obtained from these calculations is considered equivalent to the concentration of proteins in the cell-free extract in $\mu\text{g/ml}$.

The presence of α -keto- β -deoxyglucarate (KDG) was assayed according to the periodate-thiobarbituric acid test (TBA) for keto-deoxy sugar acids of Weissbach and Hurwitz (16). To 0.2 ml of sample, 0.25 ml of 0.025 M H_5IO_6 (periodic acid) in 0.125 N H_2SO_4 was added. This mixture was allowed to stand at room temperature for 20 min. After this time, 0.5 ml of 2% NaAsO_2 in 0.5 N HCl was added and allowed to stand for 2 min. Two ml of 0.3% thiobarbituric acid was then added, and the assay tube was placed in a

boiling water bath for 10 min. Addition of the periodic acid causes a cleavage of the KDG molecule in that position where two hydroxyl radicals are found attached to two adjacent carbon atoms. This results in the formation of formylpyruvate which then reacts with the thiobarbituric acid to form a pink chromogen with an absorption maximum at 551 nm. After cooling of the assay mixture, the absorbancy of the color produced is read at 551 nm against a blank which is carried through the whole procedure. A Beckman Spectrophotometer Model DB was used to read absorbancies.

The production of α -keto acids was determined by two methods. By the addition of 0.1% 2,4-dinitrophenylhydrazine in 2 N HCl to the sample being tested for the presence of α -keto acids, 2,4-dinitrophenylhydrazone derivatives of the α -keto acids were formed. The intensity of the color of these compounds can be determined in the Klett photoelectric colorimeter, equipped with a filter having a maximum transmittance at 540 nm. This procedure is found to be highly specific for the keto acids as a group (18).

The other method employed for detecting the production of α -keto acids was the semicarbazide test of MacGee and Doudoroff (19). The reagent used here contained 1% semicarbazide HCl in 1.5% sodium acetate trihydrate; 1.5 ml of this reagent was mixed with 0.2 ml of sample and 1.3 ml H₂O and allowed to incubate at room temperature for 30 min. After this time the absorbancy of the solution was measured in the Beckman DB Spectrophotometer at 258 nm against a reagent blank.

It has been reported in studies conducted by Blumenthal and Fish (8)

on the metabolism of glucaric acid by E. coli that glyceric acid and pyruvic acid were found in a 1:1 ratio. To determine whether glyceric acid was also an end-product from the metabolism of glucaric acid by A. niger, the colorimetric test devised by Bartlett (20) was used. According to this procedure, chromotropic acid, when heated with glycerate in the presence of concentrated sulfuric acid, produces a distinctive color which can be measured spectrophotometrically for identification of the glyceric acid. Under the conditions of the study being conducted here, the presence of glyceric acid was never found as a breakdown product of glucaric acid by A. niger.

Enzyme assays. To determine whether or not D-glucarate dehydrase was present within the cell and initiated the first step of the breakdown of glucarate to KDG, cell-free extracts were prepared and assayed for the presence of glucarate dehydrase (21).

Serological tubes containing 0.1 ml of the substrate disodium glucarate, prepared in a concentration of 20 umoles/ml, 0.05 ml of 0.8 M Tris-HCl buffer, pH 8.0, and 0.05 ml of 0.08 M MgSO₄, were placed in a 30 C water bath and allowed time to adjust to the incubation temperature. At selected time intervals, 0.2 ml of the cell-free extract was added to each assay tube and incubated for 10 min. The reaction was terminated by the addition of 0.1 ml 10% trichloroacetic acid (TCA). Precipitates were removed by centrifugation and the supernatant fluid tested for the presence of KDG by the TBA test. This is the product which would be formed if the enzyme glucaric dehydrase were present in the cell. The amount of KDG formed enzymatically

could be calculated from the observed change in optical density in the TBA test, using the molar extinction value of 60,000 (23).

The cell-free extract was also used to assay KDG utilization by the procedure used for the enzyme KDG aldolase (22). While the dehydrase assay is based on the formation of KDG, the KDG aldolase assay is based on the disappearance of KDG. The assay procedure employed was similar to that used in the glucaric dehydrase assay. Serological tubes were prepared containing 0.1 ml of 0.07 M $MgSO_4$ and 0.02 ml of 0.5 M potassium phosphate buffer, but the substrate used in this assay was 0.00077 M KDG, prepared according to the method of Blumenthal, Fish, and Jepson (23), and dissolved in distilled, deionized water. The tubes were placed in the 30 C water bath and allowed time to equilibrate. The cell-free extract was then added to the tubes and allowed to incubate for 10 min, after which time the reaction was stopped by adding 0.1 ml 10% TCA. The TBA test was performed on a sample of the centrifuged supernatant solution, and absorbancies were measured at 551 nm. The presence of an enzyme was demonstrated by the marked decrease in KDG originally present in the assay tubes. However, since the products TSA and pyruvate were not being measured at the same time, this assay cannot be called a KDG aldolase assay.

To calculate the amount of KDG present in the assay mixture, the optical density of the sample in the TBA test was multiplied by 2.5 (ratio of the total volume of the assay mixture to the volume of the sample being analyzed). The product was then divided by the extinction coefficient of

KDG, 60,000. This converted the measured absorbancy of the assay mixture into μ moles of KDG present in it.

Since it had been established by colorimetric procedures that α -keto acids were formed when glucaric acid was catabolized by A. niger in the presence of arsenite, enzymatic assays were used to determine whether the α -keto acid formed was pyruvic and/or α -ketoglutaric acid. In testing for the production of α -ketoglutarate, the enzyme L-glutamic dehydrogenase was used. The enzyme was obtained from Sigma Chemical Co. as a crystalline suspension in an ammonium sulfate solution. Enough ammonium ion was present in the enzyme to satisfy the NH_3 requirement. The reaction catalyzed by this enzyme was followed by measuring the oxidation of reduced diphosphopyridine nucleotide (β -DPNH) at 340 nm. According to the procedure followed (24), β -DPNH was prepared in a concentration of 8×10^{-3} M by dissolving the disodium salt in a 1% NaHCO_3 solution. Into a 1 cm cuvette, containing both the test sample and DPNH, 0.05 ml of the enzyme L-glutamic dehydrogenase was added, and the change in optical density at 340 nm was measured. From the measured change in absorbancy, the μ moles of α -ketoglutarate present in the assay mixture could be calculated.

Two similar methods were followed in determining the production of pyruvic acid (24, 25). They used the enzyme lactic dehydrogenase and measured, spectrophotometrically, β -DPNH oxidation at 340 nm against a water blank. Into the cuvette were measured the substrate being tested, β -DPNH, and a buffer (one procedure used 0.04 M triethanolamine buffer, pH 7.5,

while the other procedure used 0.05 M potassium phosphate buffer, pH 7.5). At zero time the enzyme was added and the change in optical density per minute determined. The amount of pyruvate present in the sample being tested was then calculated from the formula: $\frac{\Delta \text{O.D.} \times V}{\epsilon \times d} = \mu\text{moles pyruvate/assay mixture}$, where V = volume of the assay mixture, ϵ = the extinction coefficient of DPNH, and d = light path of the cuvette in cm.

RESULTS

Although it was reported (1) that glucaric acid was produced by Aspergillus niger when grown on a glucose-containing medium, considerable difficulty has been experienced by those trying to grow the organism on a medium containing only glucarate as the sole carbon and energy source. In a survey conducted by Fish (26) on a variety of micro-organisms grown on a glucarate medium as compared to the same micro-organisms grown on a glucose-containing medium, A. niger was found to grow very slowly and to only a very slight extent.

When glucose was substituted for glucarate in the medium used in the present investigation, the individual spores were found to germinate into small, spherical colonies with mycelia covering the surface, giving the appearance of white, fuzzy spheres. The spores inoculated into the glucarate medium germinated into gray colonies, devoid of mycelia, requiring a longer growth period than those inoculated into media containing glucose, and growing to only about one-half their size. Both of these were grown as submerged cultures on a rotary shaker at 30 C. Although less luxuriant than the growth on glucose, sufficient growth was obtained on glucarate to make a metabolic study possible.

Since it had been reported in the studies already cited that KDG was the initial intermediate product of glucarate metabolism by different bacteria using either the glycerate or α -ketoglutarate pathways, the possibility of this being the intermediate product when A. niger metabolized

glucarate was first investigated. The assay procedure for KDG involves formation of a chromogen which can be measured spectrophotometrically, thus determining the presence of KDG in the original sample.

A certain amount of difficulty was experienced in this phase of the investigation. As conducted here, a pink color should have developed only in those assay tubes in which KDG was present. However, the pink color developed even in the controls, which were samples taken from the sterile glucarate medium before being inoculated with a spore suspension of A. niger. This indicated that the commercial glucarate source, or the mono-potassium salt, was not pure D-glucaric acid, but contained at least trace amounts of KDG. In order to obtain pure glucarate for use as the carbon source in the growth medium, calcium glucarate (saccharate) tetrahydrate was used. It was necessary to pass this compound through a cation exchange resin to remove the calcium ions and allow the glucarate to go into solution. From this procedure a pure glucarate source was obtained which was subsequently used in the growth medium and as the control in the test for KDG, giving a reading of zero optical density, at a wavelength of 551 nm. Using the purified glucarate source, it was possible to demonstrate formation of KDG from glucarate by means of the TBA assay. The scheme for the reaction which occurs when KDG is assayed according to the TBA procedure is illustrated in Fig. 3.

This production of KDG from glucarate involves a dehydration, and so enzyme assays were run to establish the presence of a dehydrase within the

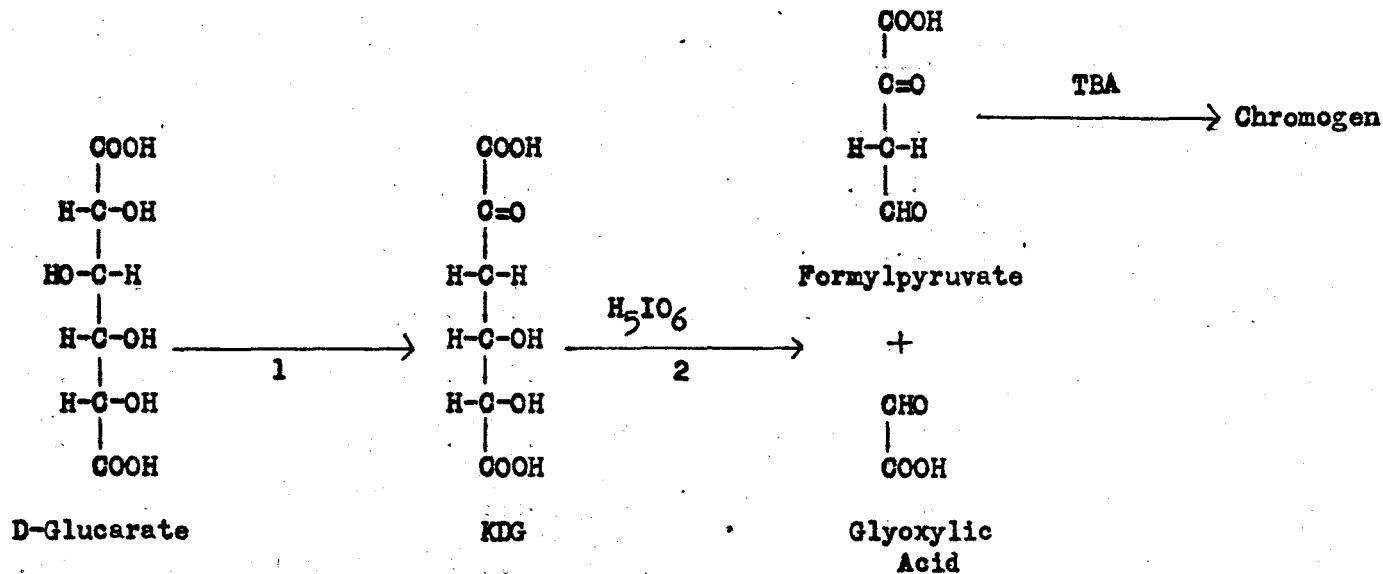

17.

1. Reaction catalyzed by the enzyme glucarate dehydrase.
2. Addition of periodic acid brings about a cleavage of the KDG molecule between adjacent carbon atoms that have hydroxyl groups.

Figure 3

Scheme for the reaction of the TBA test.

cells. Cells grown on the glucarate medium for 4 days were harvested, washed twice and then suspended in 0.05 M potassium phosphate buffer, pH 5.7, and then disrupted for 10 min by sonic oscillation. The cell suspension was then centrifuged to remove cellular debris, and the supernatant fluid, which contained the enzyme fraction, was removed.

As a method of determining the extent of cell disruption, the concentration of protein in the supernatant fluid was determined spectrophotometrically according to the method of Waddell (15, 16). This method was the best suited for the purpose since it did not require the addition of any reagents to the cell-free extract, nor did it destroy the sample. Also, the cell-free extract was diluted in a phosphate buffer which would not interfere with the reading of the absorbancy of the proteins, as other buffer solutions have been shown to do (27). About 40 μg of protein/ml were released into solution for 1 g wet weight of cells insonated. By thus determining the presence of soluble proteins in the fraction tested, a certainty was established that the procedure and duration of sonication were adequate for obtaining cell breakdown.

The remaining supernatant fraction was then assayed for dehydrase enzyme activity as described in methods. Under the conditions specified, 1.0 ml of the cell-free extract, containing about 40 μg of protein/ml, catalyzed the formation of 1.2 μmoles of KDG from 2.0 μmoles of D-glucarate, a 59.5% conversion. This gave evidence that the glucarate had been dehydrated by an enzyme present in the crude extract. In the control tubes, in

which TGA was added before the enzyme extract, there was no change in optical density; that is, no KDG was formed.

From the cell-free extract prepared by grinding the mycelia manually using glass beads, lesser amounts of KDG were found to be produced when the crude extract was added to glucarate in the enzyme assay, probably due to a larger degree of denaturation of the enzyme in solution during the cell breakdown process.

The cell-free extract prepared by sonication was also used to assay for enzymatic KDG utilization, as described in methods. From the 0.077 μ mole of KDG used as the substrate in the enzyme assay for KDG utilization, 0.026 μ mole was found to remain at the end of the reaction, indicating that sufficient enzyme was present in the cell-free extract to break down 0.051 μ mole, or about 66.2% of the KDG used.

The semicarbazide test of MacGee and Doudoroff (19) performed with samples taken from the culture medium after growth of A. niger, demonstrated the presence of α -keto acids as metabolic products of glucarate metabolism. The organism was originally grown in the culture medium containing 2% glucarate, and then these cells were harvested and washed with 0.05 M potassium phosphate buffer, pH 5.2. These washed cells were then allowed to metabolize glucarate in fresh 2% growth medium with added 0.01 M sodium arsenite to cause accumulation of α -keto acids. Samples were removed at regular intervals over a 24 hr period and the α -keto acids were determined using the semicarbazide test. The observed change in optical density,

according to this procedure, indicated that α -keto acids were being produced from the glucaric acid when metabolized by A. niger. For the first 4 hr, samples were removed every half hour; after this, samples were removed after 2 hr periods. The greatest concentration of α -keto acids was found to occur by $3\frac{1}{2}$ hr. Samples removed after this time showed no increase, and, in most cases, by 24 hr a decrease in concentration was observed (Table 1).

Similar results were obtained when α -keto acid production was tested according to the method of Friedmann and Haugen (18). Samples for this procedure were obtained in the same manner as for the semicarbazide reaction. A great increase in the intensity of the color produced when dinitrophenylhydrazones were formed, measured at 540 nm in the Klett photometer, indicated the increasing concentration of α -keto acids.

It has already been indicated that glyceric acid, which was found by Blumenthal and Fish (8) to be formed along with pyruvic acid in a 1:1 ratio when glucaric acid was catabolized by E. coli via the glycerate pathway, was not found at all after metabolism by A. niger. This analysis was performed five times: on two occasions samples were removed from the original growth medium after 4 days growth of A. niger; three other samples were removed from the arsenite containing medium after $3\frac{1}{2}$ hr incubation with the organism. When heated with chromotropic acid in concentrated H_2SO_4 , no color was produced in any of these samples, and readings of zero optical density were obtained. The control, which was a solution containing 0.2 μ mole of glycerate, gave an optical density reading of 0.48.

TABLE 1

α -KETO ACID PRODUCTION

Total α -keto acid production as determined by the semicarbazide test of MacGee and Doudoroff (19) measured at 258 nm.

Time, hr	Semicarbazide Reaction O.D. 258 Experiment Number					Average O.D. 258
	I	II	III	IV	V	
0	0.33	0.23	0.17	0.33	0.38	0.29
0.5	0.53	0.47	0.37	0.50	0.53	0.48
1.0	0.65	0.59	0.54	0.59	0.80	0.63
1.5	0.70	0.64	0.70	0.68	0.98	0.74
2.0	1.03	1.04	1.13	1.11	1.03	1.07
3.5	1.55	1.69	1.63	1.57	1.59	1.61
24.0	1.70	1.44	1.33	1.29	1.53	1.46

Enzymatic analyses were used in an effort to identify the specific α -keto acids being formed, since both pyruvic and α -ketoglutaric acids are α -keto acids. When resting cell suspensions utilized glucarate in the presence of arsenite, these analyses showed that both pyruvic and α -ketoglutaric acids were present in the supernatant liquid. Identification of each of these products was based on spectrophotometric measurement of the oxidation of DPNH to DPN, measured at an absorbancy of 340 nm. The results from five typical experiments for the determination of pyruvate and α -ketoglutarate are summarized in Tables 2 and 3.

The assay procedure for the identification of pyruvate utilized the enzyme lactic dehydrogenase, which catalyzed the reduction of any pyruvate which may have been present to lactic acid in the presence of DPNH. Results from experiments performed, as tabulated in Table 2, showed that from 190 μ moles of glucarate added, a maximum average of 173 μ moles of pyruvate were formed. This is equal to a 91% production of pyruvic acid, on an equimolar basis, or an approximately 1:1 ratio between the moles of glucarate added and the moles of pyruvate formed.

For the identification of α -ketoglutarate, the enzyme glutamic dehydrogenase was used. This enzyme catalyzes the reductive amination of any α -ketoglutarate and NH_3 to glutamic acid with DPNH being oxidized to DPN. The enzyme assays, as tabulated in Table 3, demonstrated that α -ketoglutarate was present as a metabolic end-product from the metabolism of glucarate at a maximum average of 70.7 μ moles of α -ketoglutarate formed

from 180.5 μ moles of glucarate added. This would indicate an average production of 39.2% of α -ketoglutarate from the glucarate, on an equimolar basis, when metabolized by A. niger.

TABLE 2

PYRUVIC ACID FORMATION

Determined by assay with lactic dehydrogenase in the presence of DPNH, measured at 340 nm.

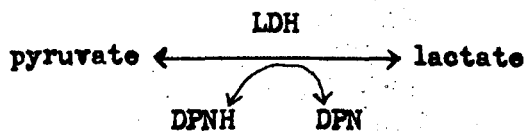

Time, hr	Pyruvate formed, μ moles Experiment Number					Pyruvate content (avg.) μ moles	Net Pyruvate formed (avg.) μ moles
	I	II	III	IV	V		
0	4.91	2.94	0.98	11.77	7.36	5.59	0
0.5	27.47	22.56	20.60	27.47	55.43	30.71	25.12
1.0	42.67	45.12	47.09	39.73	97.12	54.35	48.76
1.5	63.24	72.59	86.32	57.88	112.81	78.57	72.98
2.0	90.25	125.07	131.45	92.21	142.24	116.24	110.65
3.5	160.39	189.82	188.84	166.27	188.35	178.72	173.13
24.0	180.01	179.52	176.08	176.08	161.86	174.71	169.12

Zero hour samples were removed after inoculation of the test medium, containing 190 μ moles of D-glucarate, with the organism. From the amounts of pyruvate already found in this sample, there would appear to have been some small carryover of pyruvate from the original growth medium.

TABLE 3

α -KETOGLUTARIC ACID FORMATION

Determined by assay with glutamic dehydrogenase in the presence of DPNH, measured at 340 nm.

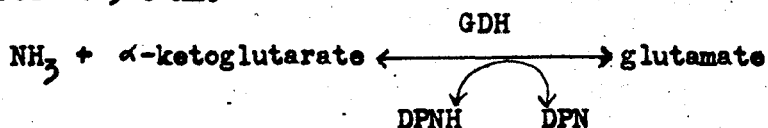

Time, hr	α -Ketoglutarate formed, μ moles Experiment Number					α -keto- glutarate content (avg.) μ moles	Net α -keto- glutarate formed (avg.) μ moles
	I	II	III	IV	V		
0	20.13	13.84	12.58	15.09	24.84	17.30	0
0.5	42.14	27.68	29.56	30.82	27.67	31.57	14.27
1.0	53.78	47.80	46.23	43.09	45.60	47.30	30.00
1.5	56.61	53.78	55.74	55.74	49.69	54.31	37.01
2.0	67.93	69.19	71.71	71.08	67.93	69.57	52.27
3.5	83.66	90.26	94.35	83.66	88.06	87.99	70.69
24.0	89.63	86.49	86.17	86.49	83.66	86.49	69.19

Zero hour samples were removed after inoculation of the test medium, containing 180.5 μ moles of D-glucarate, with the organism. From the amounts of α -ketoglutarate already found in this sample, there would appear to have been some small carryover of α -ketoglutarate from the original growth medium.

DISCUSSION

From the results presented here, it would appear that Aspergillus niger follows a metabolic pathway similar to, although not identical to, those pathways already established for other micro-organisms. Studies conducted on various bacterial species have shown that two pathways exist for glucarate metabolism. Initially, using Escherichia coli as the experimental organism, Blumenthal and Fish (8) demonstrated that one mole of D-glucaric acid was converted to one mole each of pyruvic acid and glyceric acid. This pathway was shown to involve a dehydration of the glucarate to keto-deoxy-glucarate (KDG), a cleavage of the KDG to pyruvic acid and tartronate semialdehyde (TAS), and a reduction of the TAS to glyceric acid (Fig. 1). This same glycerate pathway was found to exist in a wide variety of enteric bacteria tested.

A second pathway for glucarate metabolism was found to exist in Bacillus megaterium and pseudomonads (9,10,11). In this pathway, glucarate was dehydrated to KDG which was then dehydrated a second time to diketo adipic acid, decarboxylated to α -ketoglutaric semialdehyde, and then oxidized. This pathway is illustrated in Fig. 2.

The present study concerned itself with the same problem, namely the pathway by which D-glucaric acid is metabolized, except that the experimental organism utilized was Aspergillus niger, rather than a member of the bacterial species.

The first problem was to develop a chemically defined culture medium

containing D-glucaric acid as the sole carbon and energy source in which the test organism could grow. Once this was determined, various procedures were employed in order to identify the steps by which the organism catabolized the glucarate into products utilizable in the already known pathways of carbohydrate metabolism.

Since the development of the TBA test (17), many investigators have demonstrated the production of α -keto- β -deoxy sugar acids as intermediate products in the metabolism of many of the sugar acids. These are formed by a dehydration of the parent compound and appear to be primary intermediates in its degradation. The production of such a keto-deoxy sugar acid was also established in the present study when the presence of TBA positive material was demonstrated to be present in the supernatant liquid following glucarate metabolism when measured at an optical density of 551 nm. The first step in the catabolism of D-glucaric acid is therefore shown to involve a dehydration of the glucarate to yield keto-deoxy-glucarate (KDG). Enzyme assays, using cell-free extracts and known amounts of KDG, further demonstrated the presence of the glucarate dehydrase enzyme which catalyzed the dehydration of the substrate to KDG. Thus the first step in glucarate metabolism appears to be the same in all microbial species studied thus far.

By allowing resting cell suspensions to catabolize glucarate in the presence of arsenite, α -keto acids accumulated in the medium which were identified by both colorimetric (Table 1) and enzymatic reactions (Tables 2 and 3). Both the semicarbazide test and the formation of dinitrophenyl-

hydrazones showed that α -keto acids were indeed being formed as end-products of glucarate metabolism. Assays for pyruvate and α -ketoglutarate by enzymatic procedures showed that for every two moles of glucarate utilized, approximately two moles of pyruvate and approximately one mole of α -ketoglutarate were formed.

That KDG was actually an intermediate and was further metabolized was also established. KDG utilization by enzymes in the cell-free extract was detected using authentic KDG under the assay conditions established for KDG aldolase. A marked decrease of KDG present in the assay tubes, when measured by the TBA test at an optical density of 551 nm, demonstrated the presence of an enzyme which catalyzed this disappearance of KDG. This assay procedure was conducted in the presence of Mg^{++} , because KDG aldolase has been shown to have an absolute requirement for this cation which both activates the enzyme and is required for maximum enzyme activity (26). However, since the products of KDG aldolase, pyruvate and tartronate semialdehyde (or the reduced TSA product, glycerate) were not shown to be formed directly from the KDG, one cannot say that KDG aldolase is actually present. It is true that pyruvate was shown to accumulate when glucarate was metabolized by whole cells in the presence of arsenite. However, glycerate, the product formed from tartronate semialdehyde by reduction via tartronate semialdehyde reductase, was not detected when analyses were performed on either cells from the original 2% growth medium or from the medium to which arsenite had been added. It is obvious that further studies must be performed in order to establish the

immediate product(s) of KDG metabolism in the cell-free extracts. As further proof that KDG is an intermediate in glucarate metabolism, authentic KDG was shown to be utilized by mycelial suspensions of A. niger.

At this point, it is not clear if the glycerate and/or the α -ketoglutarate pathway, or another variation of glucarate catabolism is being used. It is conceivable, for example, that the glycerate pathway is being used and that, for some reason, the lipaic acid-mediated pyruvate dehydrogenase complex is not completely blocked by arsenite so that some α -ketoglutarate is formed via some of the reactions of the tricarboxylic acid cycle. Also, conditions may not have been appropriate to allow the accumulation of glycerate so that it was further metabolized via 3-phosphoglycerate to form a second molecule of pyruvate. On the surface, it would appear that pyruvate and α -ketoglutarate represent products of the glycerate and α -ketoglutarate pathways, respectively. However, until direct evidence for the participation of specific enzymes in these two pathways, such as KDG aldolase and tartro-nate semialdehyde reductase in the glycerate pathway and α -ketoglutarate semialdehyde dehydrogenase in the α -ketoglutarate pathway, no specific conclusions can be drawn. It is likely that the metabolism of glucarate in A. niger is different in some respects than the metabolism in bacteria. In the enteric bacteria with the glycerate pathway, for example, the presence of arsenite does not allow the conversion of pyruvate to α -ketoglutarate. In the present study there did not appear to be any indication that pyruvate formation preceded α -ketoglutarate formation, or vice versa (Tables 2 and 3).

In these analyses both products reached a maximum after 3.5 hr. Analyses which had been continued at 2 hr intervals for longer periods of time (not shown in table) showed no further increase after that time, and an analysis after 24 hr indicated that there was no further formation of either keto acid.

Although there are many avenues of investigation still to be tested and explored, an initial study of the metabolic pathway by which Aspergillus niger catabolizes D-glucaric acid has been presented here.

SUMMARY

Data obtained in this study has demonstrated that in the fungus Aspergillus niger glucaric acid is catabolized by means of a pathway involving a dehydrase enzyme and an enzyme(s) catalyzing the breakdown of KDG. Experimental results with arsenite-poisoned mycelial suspensions indicated that for every mole of glucarate utilized, approximately one mole of pyruvate was formed, and approximately 0.5 mole of α -ketoglutarate was formed. These appear to be the major metabolic end-products of glucarate metabolism, and the small amount of carbon atoms still to be accounted for may be CO_2 . The two end-products which have been identified are presumably metabolized further by known pathways. The presence of at least two enzymes in the pathway was also demonstrated. D-glucaric dehydrase was shown to catalyze the dehydration of D-glucarate to form keto-deoxy-glucarate, and an enzyme(s) catalyzing the utilization of KDG to unknown products was also shown to be present.

LITERATURE CITED

1. CHALLENGER, F., V. SUBRAMONIAN, and T.K. WALKER. 1927. Formation of organic acids from sugars by Aspergillus niger. Nature 119:674-677.
2. DEN DOOREN DE JONG, L.E. 1926. Bijdrage tot de kennis von het mineralisatieprocess. Dissertation. Nijgh and Von Ditmar's, Rotterdam.
3. KAY, H.D. 1926. Note on the variation in the end-products of bacterial fermentation resulting from increased combined oxygen in the substrate. Biochem J. 20:321-329.
4. SIMON, E. 1947. Investigations on the acetone-butyl alcohol fermentation. Arch. Biochem. Biophys. 14:39-51.
5. BLUMENTHAL, H.J. and A. CAMPBELL. 1958. Metabolism of hexaric acids by Escherichia coli. Bacteriol. Proc. 101.
6. BLUMENTHAL, H.J. 1960. D-Glucaric acid dehydrase of Escherichia coli. Bacteriol. Proc. 159.
7. FISH, D.C. and H.J. BLUMENTHAL. 1961. Enzymatic dehydration of D-glucaric acid at either of two sites. Bacteriol Proc. 192.
8. BLUMENTHAL, H.J. and D.C. FISH. 1963. Bacterial conversion of D-glucarate to glycerate and pyruvate. Biochem. Biophys. Res. Comm. 11:239-243.
9. BLUMENTHAL, H.J. and T. JEPSON. 1965. Conversion of galactaric and D-glucaric acids to α -ketoglutarate by Bacillus megaterium. Bacteriol. Proc. 82.

10. SHARMA, B.S. 1969. The metabolism of D-glucaric acid in Bacillus megaterium strain KM. M.S. thesis. Loyola University.
11. DAGLEY, S. and P.W. TRUDGILL. 1964. The metabolism of galactarate, D-glucarate and various pentoses by species of Pseudomonas. Biochem. J. 95:48-58.
12. BERNHAUER, K., H. SIEBENÄUGER, and H. TSCHINKEL. 1931. Zum Chemismus der Citronensäurebildung durch Pilze; über die Umwandlung der Zuckersäure. Biochem. Zeit. 230:466-474.
13. COCHRANE, V.W. 1958. Physiology of Fungi, p. 20. John Wiley and Sons, New York.
14. OHUGHTAI, M.I.D., A.A.PEARCE, and T.K. WALKER. 1950. Mechanism of the formation of organic acids by mold fungi. Biochem. J. 47:135-137.
15. WADDELL, W.J. 1956. A simple ultra-violet spectrophotometric method for the determination of protein. J. Lab. Clin. Med. 48:311-314.
16. MURPHY, J.B. and M.W. KIES. 1960. Note on spectrophotometric determination of proteins in dilute solutions. Biochim. Biophys. Acta. 45:382-384.
17. WEISSBACH, A. and J. HURWITZ. 1959. The formation of 2-keto-3-deoxy-heptonic acid in extracts of Escherichia coli. J. Biol. Chem. 234:705-709.
18. FRIEDMANN, T.E. and G.E. HAUGEN. 1943. Pyruvic acid II - the determination of keto acids in blood and urine. J. Biol. Chem. 147:415-442.

19. MACGEE, J. and M. DOUDOROFF. 1954. A new phosphorylated intermediate in glucose oxidation. *J. Biol. Chem.* 210:617-626.
20. BARTLETT, G.R. 1959. Colorimetric assay method for free and phosphorylated glyceric acids. *J. Biol. Chem.* 234:469-471.
21. BLUMENTHAL, H.J. 1966. D-Glucarate dehydrase. *Methods in Enzymology.* 9:660-665.
22. FISH, D.C. and H.J. BLUMENTHAL. 1966. 2-Keto-3-deoxy-D-glucarate aldolase. *Methods in Enzymology.* 9:529-534.
23. BLUMENTHAL, H.J., D.C. FISH, and T. JEPSON. 1966. Preparation and properties of α -keto- β -deoxy-D-glucarate. *Methods in Enzymology.* 9:56-59.
24. BERGMAYER, H.U. (ed.). 1963. *Methods of Enzymatic Analysis.* Academic Press, New York.
25. Worthington Laboratory Manual. 1963. Worthington Biochemical Corporation, Freehold, N.J.
26. FISH, D.C. 1964. The metabolism of D-glucaric acid in Escherichia coli. Doctoral dissertation. University of Michigan.
27. MURPHY, J.B. and M.W. KIES. 1960. Note on spectrophotometric determination of proteins in dilute solutions. *Biochim. Biophys. Acta.* 45:382-384.

APPROVAL SHEET

The thesis submitted by Barbara L. Zakes has been read and approved by the director of the thesis.

Furthermore, the final copies have been examined by the director and the signature which appears below verifies the fact that any necessary changes have been incorporated, and that the thesis is now given final approval.

The thesis is therefore accepted in partial fulfillment of the requirements for the degree of Master of Science.

6/13/69

Date

H. Blumenthal

Signature of Advisor