

ANALYSIS OF GAS PREPARATION PROCESSES FOR IMPROVEMENT OF GAS TRANSPORTATION TECHNOLOGY

Abdulaga Gurbanov

Department of Transportation and Storage of Oil and Gas¹

Ijabika Sardarova

Department of Control and System Engineering¹

Javida Damirova✉

Department of Control and System Engineering¹

cavida.damirova@asoiu.edu.az

*¹Azerbaijan State Oil and Industry University
27 Azadliq str., Baku, Azerbaijan, AZ1010*

✉ Corresponding author

Abstract

At production, collection and transport of low – pressure gas to deep water offshore platforms in sea conditions because of thermodynamic indices change in the system, complications are generated in connection with liquid phases – separation. These complications disturb normal operational well behavior, gas preparation unit and trunk (main) pipeline conditions. As a result of these phenomena high – volume losses of gas, gas condensate and chemical reagent take place.

In the process of testing, the following process parameters were determined: pressure, gas temperature, facility performance, regeneration temperature, amount of absorbent injected into the gas flow, concentration of regenerated and saturated absorbent, dry gas dew point and so on. In the process of investigating the effect of the amount of inhibitor on the degree of corrosion prevention, hydrate formation and salt deposit at the facilities, regression equations. That is why, to guarantee uninterrupted transportation of low-pressure gas in field conditions, new methods are required for these phenomena prevention.

On the basis of field study results some variants of calculation were given to increase efficiency of low-pressure gas transportation system in offshore oil and gas field's conditions.

Results of high-pressure gas optimal working pressure calculation for precipitated liquid phase displacement at low-pressure petroleum gas transportation to deepwater offshore platforms are shown in the article.

As well, method for precipitated liquid phase displacement from low-pressure gas pipeline with usage of high-viscosity elastic gelling compositions on the basis of domestic petrochemical products.

Keywords: offshore platform, condensate, liquid phase, gas pipeline, shearing stress, separator, viscosity elastic composition, pipeline, hydrate formation, thermodynamic parameters.

DOI: 10.21303/2461-4262.2021.002081

1. Introduction

Due to the intensive development of the oil and gas industry, it is necessary to develop and introduce new high-efficiency technological processes in order to increase the efficiency of technologies for the preparation and transportation of oil and gas in offshore fields.

During production, collection and transportation of oil by gas-lift method at offshore fields due to change of thermodynamic parameters in transport system technological complications associated with separation of liquid phase, i.e. produced water+condensate and other impurities from oil are formed. In addition, the formation of solid hydrates is observed, which contributes to the complete purchase of oil and gas pipelines. As a result of these complications, there are violations of the technological modes of operation of the gas lift method of oil production, operation of the oil and gas treatment plant, as well as main gas pipelines. This in turn leads to a decrease in the well flow rate and the productivity of the transport network, large losses of oil gas, gas condensate and chemical reagents [1–3].

In the article, it is necessary to determine the variation of irrigation depending on the mass fraction and density of condensate, calculate the working pressure of high-pressure gas to displace the liquid phase that collapses during the transportation of associated gas between deepwater platforms. In this way, some techniques were identified to eliminate oil and gas losses due to the shutdown of gas lift wells due to the formation of hydrates in the system. The liquid phase is prevented from entering the oil and gas pipeline in the field, which stabilizes the transport network and gas lift wells, and production increases, and the use of a complex absorbent based on local petrochemical products will eliminate the import of chemicals.

2. Materials and methods

It should be noted that many methods of producing, collecting, preparing and transporting gas and oil have now been developed and implemented. However, their rational implementation on deep-sea bases of offshore oil fields for technical and technological reasons is very complex and difficult.

In order to ensure normal oil production by the gas lift method and transport of oil and associated petroleum gas in sea conditions, a number of research and practical works were carried out. Thermodynamic and technological parameters of producing oil wells and operation mode of oil and gas pipelines on deep-sea stationary platforms of offshore fields of Azneft PA were examined using the example of «Gum Adasi» OGEE (Oil-Gas extraction enterprise).

The results of field studies showed that the length of oil and gas pipelines between sea platforms is 1.5–2.0 km, the diameter of 300 mm pipelines lie at the bottom of the sea with a depth of 10 to 50 meters.

It has been established that oil and gas pipelines at the bottom of the sea pass through very complex areas. Due to the change in terrain, the thermodynamic parameters of oil and gas change.

High-pressure gas supplied to gas elevator systems at compressor station outlet has pressure of 5.0–5.5 MPa and temperature 25–300 °C, and due to heat exchange through the wall of the pipe with seawater, their temperature decreases to 50 °C, which separates the liquid phase from the gas phase. Separated liquid gradually plugs the internal section of the gas pipeline, there is formation of hydrate plugs, which in turn reduces its productivity and complicates the normal transportation of the mixture between deep-sea sea bases [4–7].

It should be noted that in order to increase the efficiency of displacing the liquid phase into the high-pressure gas stream, it is recommended to supply chemical reagents that are capable of forming a foam system. For this purpose, it is proposed to use various surfactants. Gel-like and highly viscous elastic compositions are also proposed for cleaning pipelines from liquid phase and other impurities.

Application of this method eliminates liquid phase precipitation in the pipeline and prevents loss of oil and gas in the system. The proposed method is very simple and its implementation will require some changes in the design of the existing oil and gas equipment.

The disadvantage of this method is that it does not prevent the formation of hydrates in the system, and this leads to violations of the technological operating conditions of the wells, the entire complex and an increase in energy consumption for the process.

In order to improve the efficiency of gas preparation and transportation to gas lift wells, as well as between deep-sea bases and further to onshore oil and gas collection points, it is necessary to develop a new technology.

Based on experimental research, it was determined that the synergistic effect of the components forming the new absorbent improves the contact between the absorbent and the gas, enhances the recovery of saturated absorbent, and ensures high drying of natural gas from moisture. According to the results of industrial tests, the main physicochemical, technological parameters and optimal ratios of the components forming the absorbent, as well as the optimal technological mode of operation of gas drying unit were selected. Given that the basic indicators of transportation of the model gas produced as a result of experimental research depend on the amount of water, it is possible to calculate and predict the irrigation of any product, thereby propose an efficient variant of the mass fraction of solvent (condensate).

The process diagram of the industrial gas drying unit is shown in **Fig. 1**. The capacity of the plant is 1 million m³ gas/day. For testing according to the scheme, the plant was filled with 25 t

of new absorbent, gas from the compressor station under pressure 2.5 and 3.0 MPa, with a temperature 15–20 °C goes to the separator of the first stage S_1 , where there is a rough separation of gas from drip liquid and mechanical impurities. The gas then enters absorber A, where the gas is finally dried. For gas drying, monopropylene glycol dryer 22–25 kg per 1000 m³ of gas is supplied to absorber through dosing pump at pressure of 3.5 MPa. After contact with the gas, the moisture-saturated absorbent, passing through the heat exchangers, meets with the regenerated absorbent, heat exchange occurs, then the saturated absorbent is collected in the tanks and from there, passing through the coal and mechanical filters, enters the regeneration unit.

The regenerated absorbent is then fed into the absorber and the process is repeated in a closed circuit. Drained gas at a pressure of 2.8 MPa is sent to the gas header and further for its intended purpose [8–10].

During the test, the following process parameters were determined: pressure, gas temperature, plant capacity, regeneration temperature, amount of absorbent injected into the gas stream, concentration of regenerated and saturated absorbent, dew point of dried gas, etc.

According to the process diagram of the high-pressure gas pipeline used in the gas lift system, it is necessary to supply gas at a pressure of not less than 4.5–5.0 MPa and to supply the low-pressure gas system.

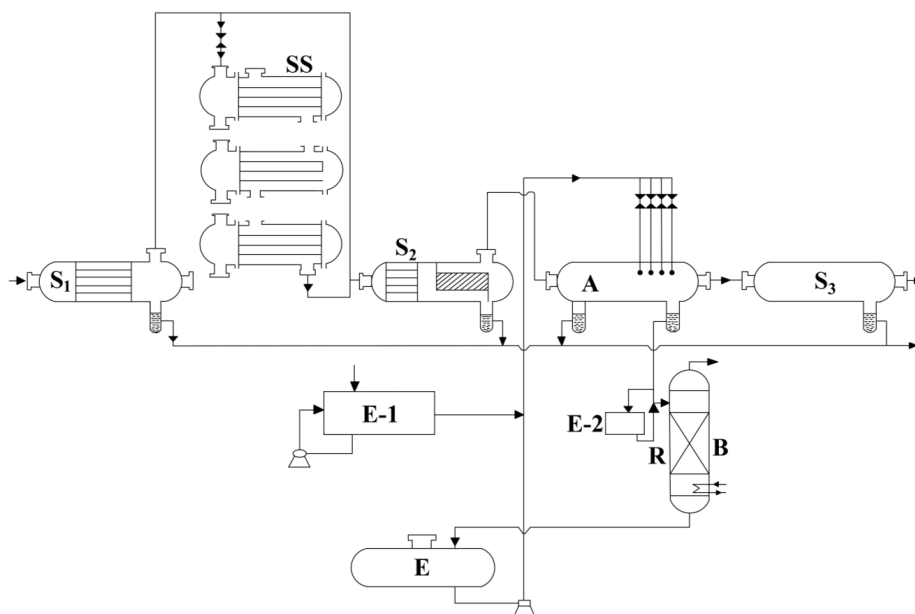

Fig. 1. Process diagram of the unit for gas drying used in the gas compressor shop of «Gum Adasi» OGEE:

S_1, S_2, S_3 – separators; SS – water cooler; A – absorber; RB – regeneration unit; E – reservoir for regenerated glycol; E-1, E-2 – capacity

Due to high-pressure gas, the liquid phase is displaced and collected in a tank 8 located on the platform.

It should be noted that in order to increase the efficiency of displacement of the liquid phase into the high pressure gas stream, the inhibitor composition in the composition contains chemical reagents that are capable of forming a foam system. Experiment planning is the procedure for selecting the number and conditions of experiments necessary and sufficient to solve the task with the required accuracy.

As a result of the experiment, a mathematical model of the object of research is presented, which means an equation that connects the process indicator with the influencing factors:

$$Y = y(x_1, x_2, \dots, x_n).$$

This equation is also called a response function.

Using the matrix of the planned experiment and the values of the output parameter, the coefficients of the regression equation are determined according to the following formulas:

$$b_i = \frac{\sum_{u=1}^n x_{iu} y_u}{\sum_{u=1}^n (\bar{x}_{in})^2}; \quad b_{ij} = \frac{\sum_{u=1}^n (x_{iu} x_{ju}) y_u}{\sum_{u=1}^n (\bar{x}_{in} \bar{x}_{ju})^2}; \quad b_{ii} = \frac{\sum_{u=1}^n (x_{iu}) y_u}{\sum_{u=1}^n (\bar{x}_{in})^2};$$

$$b_0 = \frac{\sum_{u=1}^n y_u}{n} - b_{i1} \frac{\sum_{u=1}^n (x_{iu})^2}{n} - \dots - b_{pp} \frac{\sum_{u=1}^n (x_{pu})^2}{n},$$

where n – the number of experiments; b_0 – free term of the regression equation; y_u – degree of corrosion prevention; x_{iu} – immeasurable variable quantities.

During the study of the effect of the inhibitor amount on the degree of corrosion prevention, hydrate formation and salt deposition on objects, regression equations were obtained, linking these and a number of additional factors that have a significant effect on the process. In particular, in addition to the main factor of specific delivery of the inhibitor, the influence of factors such as pressure before and after the throttle was investigated; temperature before the separator is produced water mineralization; organic acid content; CO₂ content in gas.

3. Results and discussion

Based on the processing of experimental data obtained from laboratory industrial studies, dependencies were obtained reflecting the influence of the above factors:

a) degree of corrosion prevention after use of the inhibitor:

$$Y_1 = 89.076 + 2.304x_1 - 2.183x_2 - 2.232x_3 - 1507x_4 + 74.364x_1^2 + 74.838x_2^2 + 74.339x_3^2 =$$

$$= 74.963x_4^2 + 0.131x_1x_2 + 0.744x_1x_3 + 0.294x_1x_4 + 2.556x_2x_3 - 0.244x_2x_4 + 0.869x_3x_4;$$

b) degree of salt deposition prevention

$$Y_2 = 83.56 + 4.576x_1 - 2.875x_2 - 6.613x_5 + 73.79x_1^2 + 75.74x_2^2 + 72.93x_5^2 -$$

$$- 0.4x_1x_2 + 1.275x_1x_5 - 0.025x_2x_5;$$

c) on the degree of prevention of hydrate formation

$$Y_3 = -16.444 - 0.006x_1 + 1.374x_8 - 0.0061x_6 - 0.0058x_7 - 0.0062x_2,$$

where Y_1 – corrosion protective effect as a result of using inhibitor, %; Y_2 – salt deposition, %; Y_3 – hydrate formation (a dew point after separation), °C; x_1 – specific inhibitor supply, kg/1000m³; x_2 – temperature of °C on an entrance; x_3 – organic acid content, mg/l; x_4 – the maintenance of CO₂ in gas, % about; x_5 – mineralization of produced water, (g/l); x_6 – pressure to a throttle, MPa; x_7 – pressure after a throttle, MPa; x_8 – the ambient temperature, °C.

The adequacy of the above equations was tested by the Fisher criterion for significance level $\alpha = 0.05$. Reproducibility variance was calculated from five parallel experiments. All coefficients included in these equations are significant according to Student's criterion.

The variation intervals of the influencing parameters were selected according to the variation range of the current process parameters. The obtained regression equations use dimensionless variables x_i , which are obtained from dimensional by the following formula:

$$x_i = (x_i - x_i^*): \Delta x_i,$$

where x_i – dimensional variable; x_i^* – value of the variable at the base level; Δx_i – variation interval.

The application of the experiment planning method to the presented statistics made it possible to find a relationship between the output parameters of interest and a number of factors influencing the process, minimize the number of necessary experiments and at the same time identify the optimal value of the desired function.

On the basis of the obtained model, calculations and optimization of the investigated processes can be carried out.

Inhibitor consumption rates are determined by the following formula:

$$C_1 = K_e \times (D_m + D_g + D_k),$$

where D_m – inhibitor losses with water vapors released from the gas, g/1000 m³; D_g – loss of inhibitor with gas phase, kg/1000 m³; D_k – loss of inhibitor with hydrocarbon condensate; K_e – operating factor of inhibitor, $K_e = 1.05$.

The flow rate of the gas phase inhibitor depends on the moisture content of the gas and the concentration of the inhibitor injected into the gas stream.

The calculation is based on the following formula:

$$D_m = [(W_1 - W_2) \times C_2] : C_1 - C_2,$$

where W_1 , W_2 – amount of water vapors in the gas phase before and after injection of the inhibitor, respectively, kg/1000 m³; C_1 , C_2 – concentrations of the inhibitor pumped into the gas stream and spent inhibitor, respectively, wt %.

The results of the studies show that the gas density in the offshore oil and gas fields of the Republic of Azerbaijan is 730 kg/m³. When transporting gas, methyl alcohol is used as an inhibitor. The density of the inhibitor depends on a decrease in the hydrate formation temperature and physicochemical properties of the inhibitor and is determined by the formula:

$$C_2 = [(M+T) : (M \times \Delta T + K)] \times 100,$$

where C_2 – density of the inhibitor used in the gas stream, %; M – molecular weight of methyl alcohol, $M = 60$; K – methyl alcohol constant, $K = 1250$; T – depression of hydrate formation temperature.

$$\Delta T = T_{hyd} + T_p,$$

where T_{hyd} – temperature of hydrate formation of gas, °C; T_p – gas temperature during injection of methyl alcohol into the gas stream at the process point.

Using the graph shown in **Fig. 2**, the equilibrium state of the hydrate formation temperature is determined depending on the temperature phenomenon and the specific gravity of the natural gas.

To carry out the calculation, «Gum Adasi» OGEE is taken as an example. Actual gas pressure and temperature in gas elevator systems and gas transportation to «Gum Adasi» OGEE:

$$P_{qazl.} = 6.0 \div 6.2 \text{ MPa}; T_{qazl.} = 20 \div 22 \text{ } ^\circ\text{C};$$

$$P_{trans} = 1.5 \div 2.0 \text{ MPa}; T_{trans} = 7 \div 10 \text{ } ^\circ\text{C}.$$

It is known that during the transportation of gas due to a drop in temperature and pressure, hydrates are formed. For the «Bahar» field, hydrate formation conditions are as follows:

$$P_{qazl.} = 6.0 \div 6.2 \text{ MPa}; T_{qazl.} = +16 \div (+17) \text{ } ^\circ\text{C};$$

$$P_{trans} = 1.5 \div 2.0 \text{ MPa}; T_{trans} = +3.5 \div (+7) \text{ } ^\circ\text{C}.$$

Temperature of the gas transported on the coast and used in a gas-lift system in initial and final technological points is $+20 \text{ } ^\circ\text{C}$ and $+5 \text{ } ^\circ\text{C}$, it corresponds to conditions of formation of hydrates in a system.

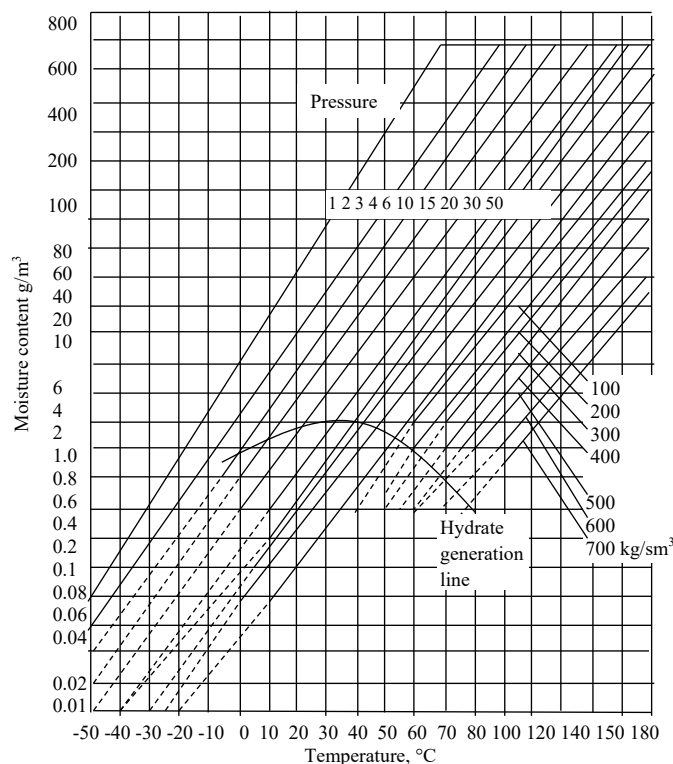

Fig. 2. Nomogram for determination of moisture content of natural gases

For reduction of temperature of hydrate formation and providing accident-free transport of gas, it is necessary to reduce its temperature till $20\text{--}25 \text{ } ^\circ\text{C}$. To do this, it is necessary to determine the concentration of methyl alcohol by the following formula:

$$C_2 = (M+T):(M \times \Delta T + K);$$

$$C_2 = (60 \times 25):(60 \times 25 + 1250) = 54.5 \text{ \% mass}.$$

In both cases, the concentration of methyl alcohol should be 54.5 \% to reduce the hydrate formation temperature. When calculating, the actual indicators of gas lift operation and gas transportation systems from the «Bahar» field to the onshore structures of «Gum Adasi» OGEE (Table 1) were used.

Table 1

Data used in the calculation

Key indicators	At the beginning of the gas pipeline	At the end of the gas pipeline
Pressure of gas transported to shore, MPa	2.0	1.5
Gas temperature, transported on the coast, wasps $^\circ\text{C}$	+13	+5
Gas moisture content, kg/1000 m^3	0.45	0.15
Hydrate formation temperature in equilibrium, $^\circ\text{C}$	-5; +8	-
Decrease in temperature of hydrate formation, wasps $^\circ\text{C}$	25	25

The calculation is carried out in the following sequence.

The amount of methyl alcohol inhibitor required for saturation of the liquid phase is determined according to the formula:

$$D_{liq.} = [(0.40 - 0.15) \cdot 54.5] : (87 - 54.5) = 0.42 \text{ kg/1000 m}^3.$$

Thus, the flow rate of the inhibitor for saturation of the liquid phase is 0.42 kg/1000 m^3 . As is known, the methyl alcohol supplied to the gas stream is transferred to both the liquid and gas phases.

The consumption of methyl alcohol is determined by the following formula:

$$D_{gas} = 0.1 \times \alpha \times C_2,$$

where α – the amount of methyl alcohol required for saturation of gas phase, relative to concentration spent aqueous solution of methyl alcohol; C_2 – amount of alcohol recovered from the gaseous phase of the aqueous solution is determined according to the schedule at the specified temperature and pressure. Under these conditions $\alpha = 22$.

$$D_{gas} = 0.1 \times 22 \times 0.42 = 0.924 \text{ kg/1000 m}^3.$$

The sum of the consumption of methyl alcohol in the liquid and gas phases is:

$$D_{liq} + D_{gas} = 0.42 + 0.924 = 1.344 \text{ kg/1000 m}^3.$$

Further, the inhibitor losses are determined by dissolving it in the hydrocarbon condensate D_{cond} .

As noted above, the solubility of the inhibitor in the hydrocarbon condensate is 0.1 %, that is, the loss of the inhibitor is 1 % of its total flow rate.

$$D_{cond.} = 1.344 \times 0.01 = 0.0134 \text{ kg/1000 m}^3.$$

Alcohol losses in water, gas and condensate are determined as follows:

$$C_{1\ sol} = D_{wat} + D_{gas} + D_{cond};$$

$$C_1^F = 0.42 + 0.924 + 0.0134 = 1.357.$$

The next stage of calculation depends on the amount of free water supplied with natural gas. Experience has shown that it is difficult to determine the amount of free water coming from gas flow wells is about 10–15 % of the methyl alcohol flow rate. According to the regulations, the amount of free water relative to the inhibitor consumption is 20–30 %. Thus, taking into account the amount of free water supplied, the estimated inhibitor flow rate should be 10–15 % higher:

$$C_1 = 1.357 \times 0.15 = 0.203 \text{ kg/1000 m}^3 \text{ gas.}$$

Final methyl alcohol consumption calculated:

$$C_1 = 1.05 \times (0.42 + 0.924 + 0.0134 + 0.203) = 1.72 \text{ kg/1000 m}^3.$$

To ensure hydrate-free operation in OGEE industries, the consumption of methyl alcohol used in the gas lift mode is 1.72 kg/1000 m^3 . Considering that the technical and technological parameters often change in the fisheries, the consumption rates of the inhibitor should be specified annually.

Use of the proposed complex action will make it possible to increase intensity of displacement of fallen liquid phase and prevent formation of hydrate plugs in system of gas transportation between deep-sea gas-lift wells at fields.

Application of this method eliminates liquid phase precipitation in pipeline and prevents formation of hydrates in system and allows efficiency of gas-lift method of oil production.

The proposed method is very simple; its implementation will require some changes in the technology of the existing gas field equipment.

In addition to the above methods, gel-like and highly viscous elastic compositions are proposed for cleaning the low pressure pipeline from the liquid phase and other impurities.

When implementing this development in the system of field preparation and transportation of oil and gas at offshore fields:

- oil and gas losses of gas lift wells shutdown are excluded due to formation of hydrates in the system;
- prevention of ingress of the liquid phase on the in-line oil and gas pipeline, due to which the technological mode of operation of the transport network and gas lift wells is increased and stabilized;
- gas consumption during oil production and transportation is significantly reduced;
- use of a complex absorbent developed on the basis of domestic petrochemical products will exclude the purchase of imported chemical reagents.

The use of this method eliminates the deposition of the liquid phase in the pipeline and prevents the formation of hydrates in the system, allowing to ensure the efficiency of oil production by gas lift.

Thus, the working pressure of high-pressure gas being necessary to compress the liquid phase deposited during the transportation of direction gas between deep-sea platforms was determined by calculation.

According to the positive results of the research, the presence of the absorbent has a beneficial effect on the technological process, the contact between the absorbent and the gas improves, and the recovery of saturated absorbent intensifies.

Based on the results of the industrial tests, optimal technological mode of operation of gas dehydration unit was selected. It was determined that the quality of the proposed absorbent gas fully meets the requirements of the industry standard.

The design method established the working pressure of high-pressure gas to displace the liquid phase that fell out during the transportation of associated petroleum gas between deep-sea offshore platforms.

On the basis of the positive results of the conducted studies, the main physicochemical, technological parameters and the optimal ratio of the components included in the absorbent were chosen.

The results of experimental studies showed that when mixing the components that make up the new absorbent, a synergistic effect arises, due to which a high degree of drying of natural gas from moisture is achieved.

The presence of the absorbent has been found to have beneficial effects on the process, improved contact between the absorbent and the gas, and intensified regeneration of the saturated absorbent.

On the basis of the results of the industrial tests, the optimal process mode of the gas drying unit was chosen. The proposed absorbent has been found to fully meet the requirements of the industry standard.

4. Conclusions

By using the way of calculation, the working pressure of the high-pressure gas was established to displace the liquid phase precipitated during the transportation of associated petroleum gas between deep-sea offshore platforms.

On the basis of the positive results of the research carried out, the main physicochemical, technological indicators and the optimal ratio of the components forming the absorbent were selected.

The results of experimental research have shown that when mixing the components forming a new absorbent, a synergistic effect arises, due to which a high degree of drying natural gas from moisture is achieved.

Based on local chemicals, the application of an environmentally friendly and effective composition inhibitor simplifies the technology of the gas treatment unit, as the unit ensures drying of the gas from water vapor and at the same time cleans it from harmful components.

It is found that the presence of the absorbent favorably affects the technological process, the contact between the absorbent and the gas is improved and the regeneration of the saturated absorbent is intensified.

Based on the results of the conducted industrial tests, the optimal technological mode of gas installation was selected. It was established that the proposed absorbent fully ensures the quality of gas in accordance with the requirements of the industry standard.

Acknowledgments

We are grateful to the authorities of «Gum Adasi» Oil-Gas extraction enterprise and to A. Mustafayev implementing gas separation for their assistance.

References

- [1] Miralamov, H. F., Ismayilov, G. G. (2010). Transportation of oil and gas by pipelines. SOCAR NGETLI publishing house. Baku, 505.
- [2] Gurbanov, A. N. (2010). Technological calculation of gas drying using new absorbent. Development of oil and gas generation, 2, 140–144.
- [3] Kvon, V. G., Istomin, V. A., Durov, V. A., Boyarchuk, K. V., Manakov, A. Yu. (2006). Method for calculating the conditions of hydrate formation for high pressures. Science and technology in the gas industry, 4, 67–74.
- [4] Sardarova, I. Z., Mehdiyeva, A. M., Gurbanov, A. N. (2020). Application of discrete averaging to increase the accuracy of multiple measurements. Proceedings of the Institute of Applied Mathematics, 9 (2), 150–157. Available at: http://www.iamj.az/Files/Contents%20V.9,%20N.2,%202020/7Sardarova_Mehdiyeva%20_Qurbanov%20N.pdf
- [5] Buts, V. V. (2010). Mathematical model of formation of hydrates in pipelines. XXIII-International Scientific Conference. Mathematical Methods in Engineering and Technology. MMTT-23. Saratov: SSTU, 78–83.
- [6] Gurbanov, A. N. (2011). Improving the technology of collecting and transporting nizkona the gas between deepwater offshore platforms. Moscow: Petroleum Engineering, 39–42.
- [7] Gurbanov, A. N., Sardarova, I. Z. (2020). Main fight direction against formation of hydrate, corrosion, and environmental pollution on producing, transporting, and storing of natural gas. The 7th International Conference on Control and Optimization with Industrial Applications. Baku, 143–145. Available at: http://www.coia-conf.org/upload/editor/files/COIA20_V2.pdf
- [8] Kvon, V. G., Istomin, V. A., Durov, V. A., Boyarchuk, K. V., Manakov, A. Y. (2006). A method for calculating the conditions of hydrate formation for high pressures Science and technology in the gas industry, 4, 67–74. Available at: <https://www.elibrary.ru/item.asp?id=11838649>
- [9] Vigneron, A., Head, I. M., Tsesmetzis, N. (2018). Damage to offshore production facilities by corrosive microbial biofilms. Applied Microbiology and Biotechnology, 102 (6), 2525–2533. doi: <https://doi.org/10.1007/s00253-018-8808-9>
- [10] Rapp, B. E. (2018). Electrochemical Methods for Biomass and Biocorrosion Monitoring. Encyclopedia of Interfacial Chemistry, 166–172. doi: <https://doi.org/10.1016/b978-0-12-409547-2.13507-3>

Received date 28.03.2021

Accepted date 21.09.2021

Published date 18.11.2021

© The Author(s) 2021

This is an open access article
under the Creative Commons CC BY license

How to cite: Gurbanov, A., Sardarova, I., Damirova, J. (2021). Analysis of gas preparation processes for improvement of gas transportation technology. EUREKA: Physics and Engineering, 6, 48–56. doi: <https://doi.org/10.21303/2461-4262.2021.002081>