

We are IntechOpen, the world's leading publisher of Open Access books Built by scientists, for scientists

5,800

Open access books available

142,000

International authors and editors

180M

Downloads

Our authors are among the

154

Countries delivered to

TOP 1%

most cited scientists

12.2%

Contributors from top 500 universities



WEB OF SCIENCE™

Selection of our books indexed in the Book Citation Index
in Web of Science™ Core Collection (BKCI)

Interested in publishing with us?
Contact book.department@intechopen.com

Numbers displayed above are based on latest data collected.
For more information visit www.intechopen.com



The Transient Reactor Test Facility (TREAT)

Nicolas Woolstenhulme

Abstract

Constructed in the late 1950s, the Transient Reactor Test facility (TREAT) provided numerous transient irradiations until operation was suspended in 1994. It was later refurbished, and resumed operations in 2017 to meet the data needs of a new era of nuclear fuel safety research. TREAT uses uranium oxide dispersed in graphite blocks to yield a core that affords strong negative temperature feedback. Automatically controlled, fast-acting transient control rods enable TREAT to safely perform extreme power maneuvers—ranging from prompt bursts to longer power ramps—to broadly support research on postulated accidents for many reactor types. TREAT's experiment devices work in concert with the reactor to contain specimens, support in situ diagnostics, and provide desired test environments, thus yielding a uniquely versatile facility. This chapter summarizes TREAT's design, history, current efforts, and future endeavors in the field of nuclear-heated fuel safety research.

Keywords: transient testing, fuel safety research, accident simulation

1. Introduction

In the late 1950s, the Transient Reactor Test facility (TREAT) was designed, constructed, and commissioned within the span of only a few years [1]. The facility was built just over 1 km away from the Experimental Breeder Reactor-II (EBR-II) sodium-cooled fast breeder reactor as part of the Argonne National Laboratory West campus (ANL-W) located in the Arco Desert, west of Idaho Falls, Idaho. As with most facilities at ANL-W, TREAT was originally envisioned to help support research and development pertaining to EBR-II, but its mission diversified in later years to support other nuclear technology areas. TREAT was a specialized graphite-based test reactor able to safely perform extreme transient power maneuvers to research the effects of postulated accident conditions on nuclear fuel specimens placed in its core [2, 3]. A modern aerial image of TREAT is shown in **Figure 1**.

TREAT's unique abilities stem from its fuel assemblies, in which uranium oxide, graphite, and carbon powders are mixed with binders, pressed into blocks, and fired at high temperatures [4]. The resulting fuel blocks were stacked inside zircaloy-3 sheet metal canisters (a uniquely oxidation-resistant zirconium alloy that was being researched at the time, but which is no longer in production, having been superseded by other zirconium alloys for light-water reactor [LWR] use). These canisters were evacuated and sealed. Aluminum sheaths and end fitting hardware were fastened to the tops and bottoms of these fuel assemblies to house graphite reflectors and provide mechanical interfaces for gridplate placement and handling. These fuel assemblies had a $\sim 10 \text{ cm}^2$ cross section with 0.6 m of unfueled axial



Figure 1.
Modern day aerial image of TREAT.

reflector top and bottom with 1.2 m of active fueled length in the center. Various special fuel and graphite dummy assemblies were also produced, including some with central cylindrical cavities for control rods, some with integral thermocouples, and some with a void region (i.e., containing no fuel or moderator) in the core's axial center (see Figure 2) [5].

The resulting fuel assemblies were produced in sufficient quantity to fill the reactor's 19×19 square-pitch gridplate array. Despite thousands of reactor startup and transient cycles over the decades that followed, the fluence experienced during short transients was small, and these same fuel assemblies accumulated very little burnup. Hence, TREAT operates to this day using the original fuel assemblies produced in the 1950s. Occasionally, these fuel assemblies are shuffled into different reactor positions or stored below grade in adjacent storage holes. Core reconfigurations are performed to optimize the core parameters for experimental needs rather than to equilibrate burnup as is typical of most nuclear reactor shuffling schemes. The radionuclide inventory of these fuel assemblies is minimal, and they can be handled without shielding, especially after an extended decay period

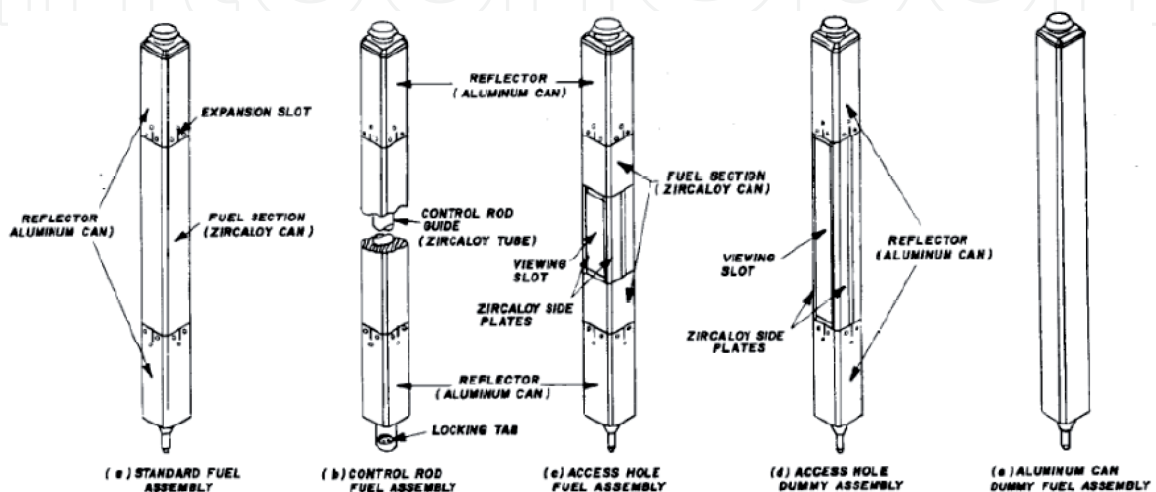

Figure 2.
Historic image of TREAT fuel assembly types.

between transient operations. Still, these fuel assemblies are typically handled in a lead-shielded cask outside the reactor to reduce personnel radiation exposure.

TREAT's active core region resided just above ground level. The reactor is surrounded by a thick wall of graphite reflector blocks. TREAT's graphite reflector is surrounded by thick walls of concrete that comprise both the reactor's main structural shell and its radiation shielding. Blocks can be removed from some parts of the graphite reflector and concrete shielding to create a void slot for viewing the core center from each of the four cardinal directions. Presently, the west slot is occupied by a collimated-beam neutron radiography facility adjacent to the reactor. The north slot is occupied by the Fuel Motion Monitoring System (FMMS), also known as the hodoscope. The east slot area is filled with normal fuel assemblies with a large graphite region in the concrete wall and rolling shield door give access to a highly thermalized neutron environment referred to as the thermal column. The south slot is currently unused, but could be outfitted with other scientific instruments or facilities in the future.

The concrete walls support a ~30 cm-thick circular upper shield plug approximately 3 m in diameter. This shield plug can rotate 360 degrees on bearings via a gear drive. A rectangular slot through the shield plug extends from its center to its periphery. All fuel assemblies, experiments, and other hardware are installed in TREAT through this slot, using bottom loading shielded casks and/or overhead cranes. A ~1 m gap between the top of the fuel assemblies and the bottom of the rotating shield plug provides space for TREAT's control rods to protrude above the core. See **Figures 3** and **4** for an overview of some of the reactor's key features.

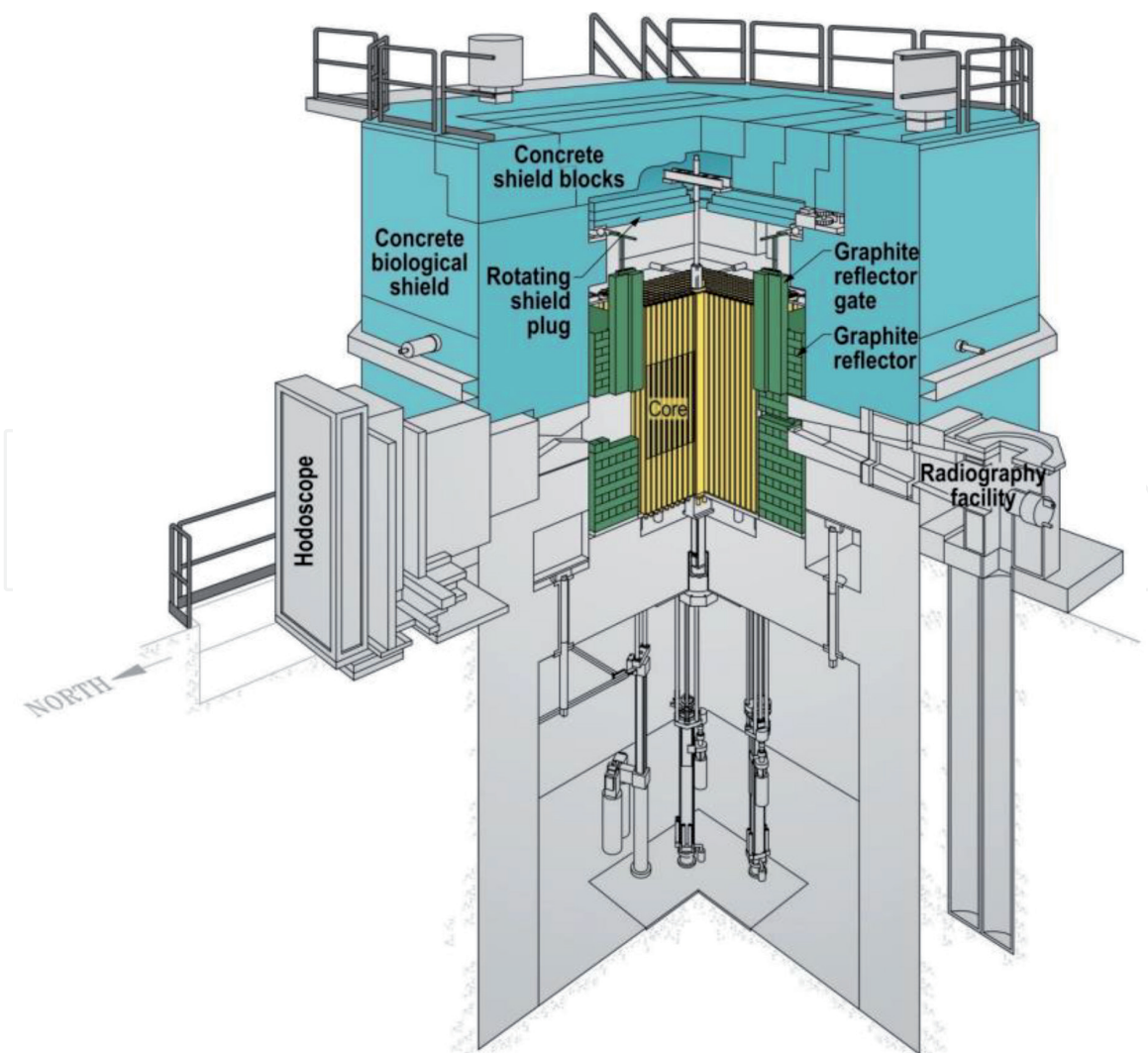

Figure 3.
Section view of TREAT's key reactor features [6].

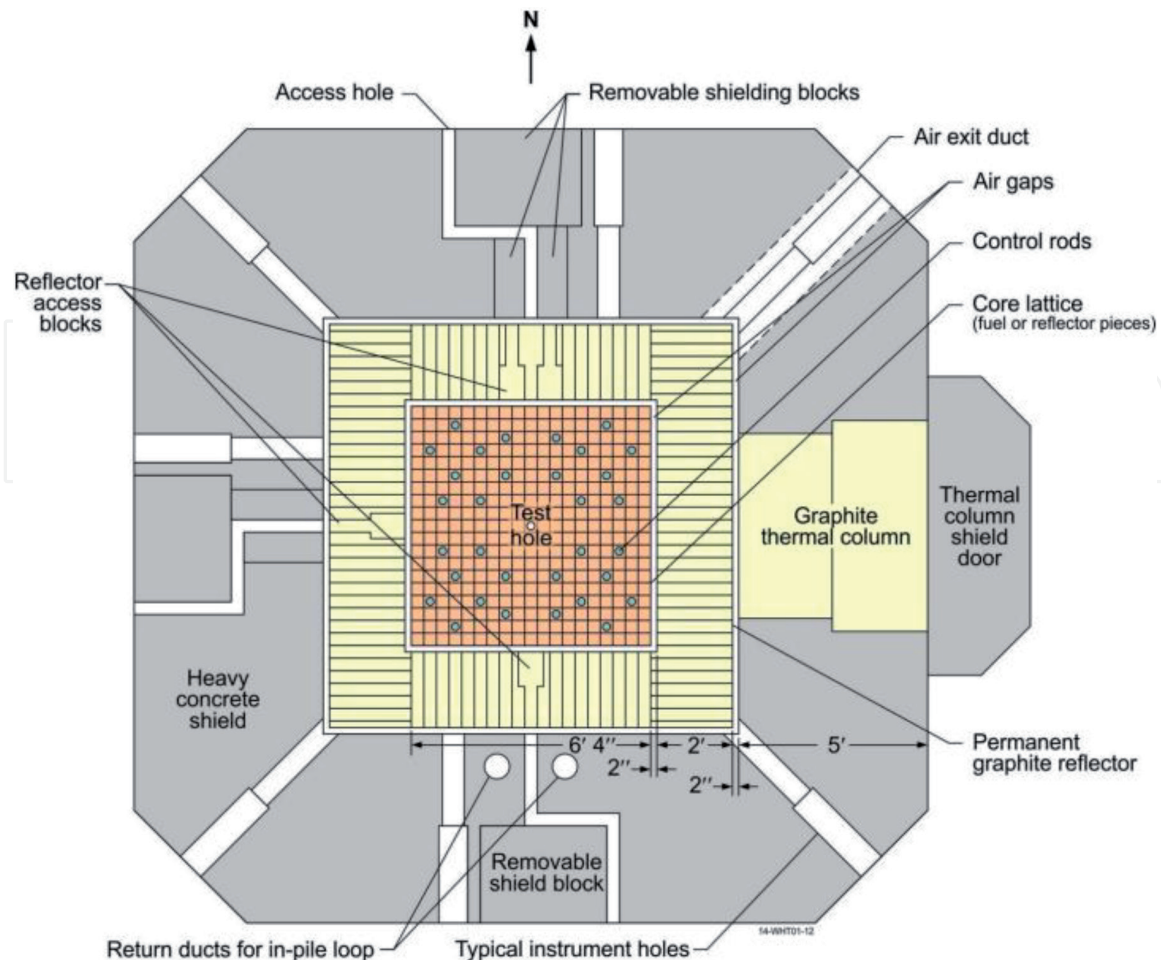

Figure 4.
Top view of TREAT's core, reflector, and shielding layout [6].

Apart from experimental devices that may contain various liquids to support the desired specimen boundary conditions, TREAT does not house liquid coolant for the reactor itself. Instead, a blower system pulls air from the reactor building through debris filters located atop the reactor, down into the core (primarily through $\sim 1 \text{ cm}^2$ coolant channel gaps where the corner chamfers of four fuel assembly canisters meet), and out through a filtration system and stack. This air-cooling system is adequate to enable the reactor to operate in low-level steady-state (LLSS) mode for several hours at a time. Presently, TREAT is authorized to operate in LLSS mode at up to 120 kW thermal power, but this power level does not challenge facility physical limitations and could likely be uprated if needed. LLSS mode is useful for calibrations, system check outs, dosimeter irradiations, and neutron radiography. This cooling system is inadequate for removing significant heat within the time duration of a fast transient; hence, it is not credited for transient safety calculations. Therefore, the core's heat capacity and high-temperature oxidation of fuel assembly canisters typically set the core transient energy capacity at around 2500 MJ, depending on the core configuration. The cooling system also helps cool down the core after large transients, thus boosting operational efficiency. In this manner, TREAT can typically perform one large transient per day—and occasionally two moderate-energy transients in a one-day shift.

TREAT's unique core design is complimented by its specialized control rod systems, thus enabling its unparalleled transient capabilities. All TREAT's control rod types use boron carbide in the absorber section, along with graphite-filled zirconium alloy followers. Reactor operation is initiated by withdrawing compensation and transient rod sets (the compensation rods' purpose is to ensure that hold-down reactivity margins are maintained during the removal of large experiment devices, many of which are net neutron sinks). The reactor is then brought critical by moving the control/shutdown

rod sets out of the active core. LLSS operations are typically performed with the rods in this configuration. Transient control rods can then be inserted incrementally to prepare for transient operations, while the control/shutdown rods are withdrawn to maintain criticality until the desired excess reactivity is available in the transient rods. The reactor is then switched into transient mode, and a preprogrammed transient power shape is executed by an automatically controlled computer system with active feedback from ion chamber neutron detectors located in TREAT's concrete shielding. See **Figure 5** for an example core map showing these control rod locations.

Transient rods are driven by fast-acting hydraulics in the TREAT basement sub-pile room (see **Figure 6**). These rod drives can move the rods at a velocity of ~3.5 m/s in both directions (i.e., up and down), permitting split-second manipulation of the reactor's power shape. A tremendous number of transient shapes can be executed, including prompt pulses, ramps, flattop regions, and combinations thereof [7]. (See **Figure 7** for examples of possible power shapes in TREAT.) Transient operation can be "clipped," based on the desired test conditions, by rapidly inserting the transient control rods to narrow the TREAT natural pulse width to <90 ms (full width at half max) and terminate the reactor power. Further upgrades are planned for expanding TREAT's clipping capability to include even narrower pulses when needed [8].

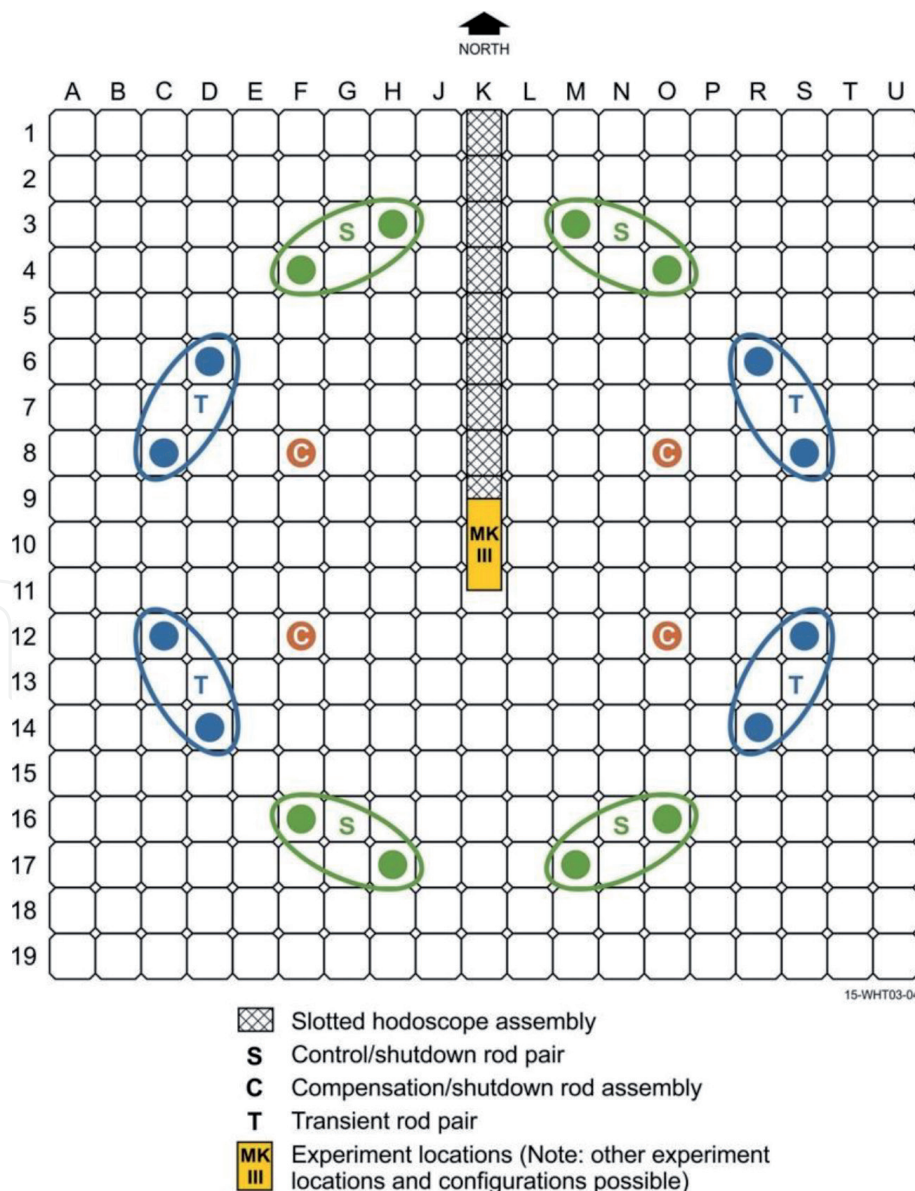

Figure 5.
 Example core map showing current control rod types and locations.



Figure 6.
View of TREAT rod drive mechanisms from the sub-pile room.

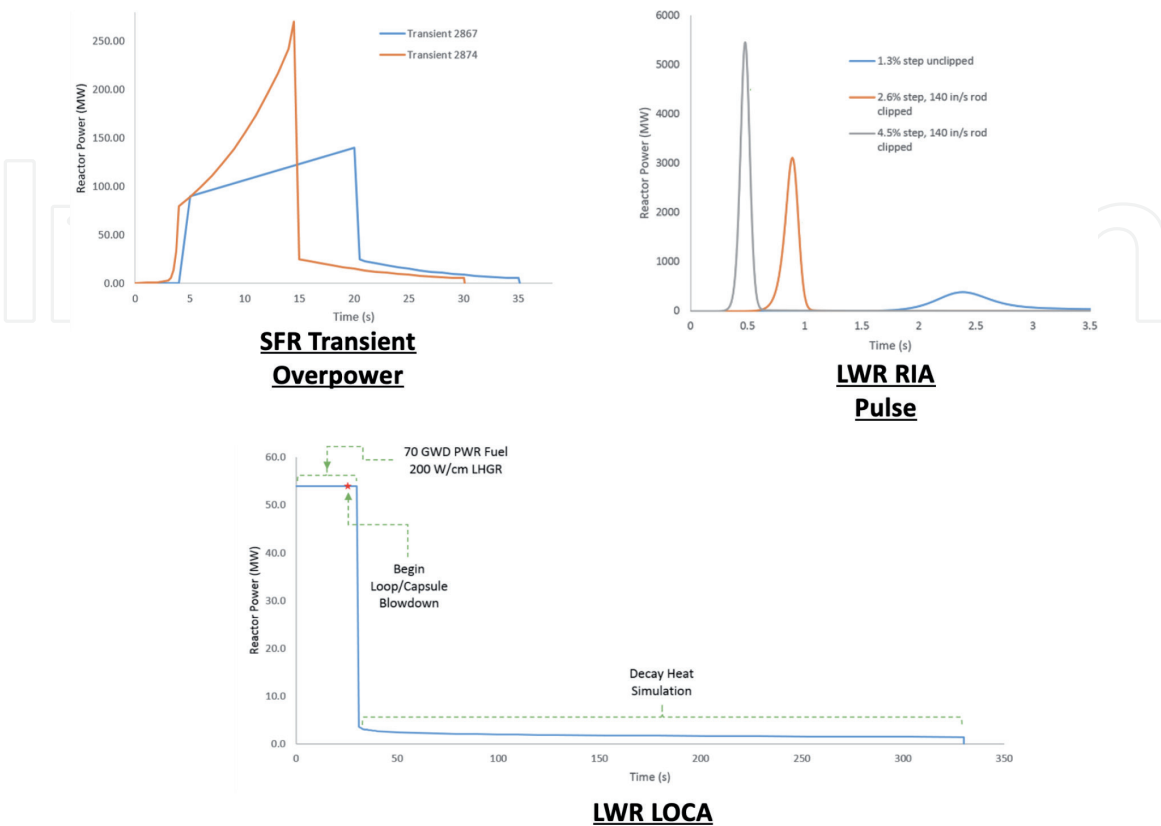

Figure 7.
Example transient shapes possible at TREAT.

Under certain conditions, a state-of-the-art reactor trip system will initiate the rapid insertion of all rods; however, as with the air-cooling system, the trip system is not credited in the reactor safety basis. Instead, TREAT's strong negative temperature feedback behavior is credited as the primary means of limiting transient energy. Since TREAT's uranium oxide particles are dispersed in the fuel blocks, power excursions cause the moderator temperature to rise, resulting in higher neutron energy, increased neutron leakage, and self-limiting power excursions with reliable negative temperature reactivity coefficients. This key feature of TREAT enables it to safely perform research on nuclear fuel specimens under extreme conditions.

2. Facility history

The Arco Desert, where TREAT and ANL-W were built, has also housed many other test reactors as part of the National Reactor Testing station and Naval Reactor Facility missions. A series of water-based transient test reactors were constructed under the Special Power Excursion Reactor Test (SPERT) program that was contemporary to TREAT in its early years [9]. Together, SPERT and TREAT used water capsules to conduct most of the foundational research on overpower fuel performance thresholds for LWRs. During this time, TREAT also continued to perform research on sodium fast reactor (SFR) fuels and nuclear thermal propulsion (NTP) fuels using specialized test capsules. Later, two additional landmark facilities were built out in the Arco Desert to advance research on the accident behavior of LWR fuels. The Power Burst Facility (PBF) offered unrivaled capabilities for reactivity-initiated-accident testing of fuel rods in an integral pressurized flowing loop [10], while the Loss-of-Fluid Test Facility (LOFT) addressed system-scale safety testing via its seminal work in loss-of-coolant-accident testing [11]. These features, along with the postmortem exams performed by facilities in the Arco Desert on fuel from the Three Mile Island accident made Idaho the nexus of fuel safety research throughout the 1980s.

With PBF and LOFT focusing on LWR safety research TREAT's latter historic era naturally shifted toward a focus on SFR fuels using clever sodium loop test vehicles. The Mk-series loops could test bundles of up to seven pins using compact electromagnetic pumps to recirculate sodium through a small pipe weldment [12]. The entirety of these loops was small and self-contained to foster transportation between TREAT and the adjacent Hot Fuel Examination Facility (HFEF) on the main ANL-W campus. Casks established for this purpose could house sodium loops and other experiments measuring up to 25 cm in diameter by 3.6 m tall. HFEF was used to assemble fuel pins irradiated in other test reactors (e.g., EBR-II) into these TREAT test loops, and to extract/examine these pins after transient irradiation. Today, HFEF remains in operation as a global hub for post-irradiation examinations.

Unlike reactors such as PBF, TREAT was not designed from the ground up with integral piping for test loops. Thus, the most common type of TREAT experiment design is well represented by the successful Mk-series sodium loops. Referred to as package- or cartridge-type experiments, this design approach used a compact, robust, experiment containment vessel to provide the desired specimen boundary conditions and contain all chemical, radiological, and mechanical hazards associated with the test (see **Figure 8**). These devices, which fit entirely within casks, were installed by being lowered into the reactor and then connected to power/signal lead on the top flange. These leads were routed through the slot in the rotating shield plug and to the necessary control and data acquisition equipment. The absence of liquid coolant or pressure vessel surrounding the reactor simplified lead routing for facilitating transient tests in which real-time experiment data was crucial for understanding the data objectives. This package-type approach was key for enabling TREAT to address specimen coolant conditions and research needs for a variety of reactor designs [13].

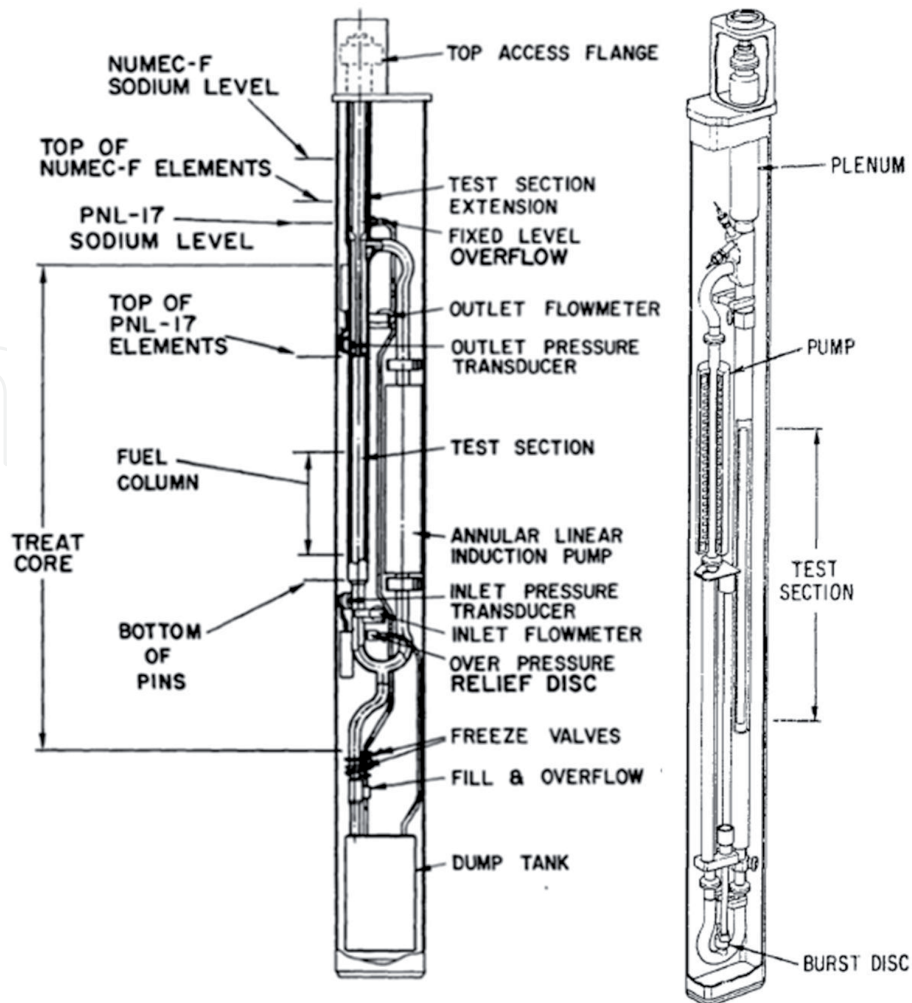

Figure 8.
Historic images of Mk-series sodium loop designs.

TREAT performed numerous tests on oxide-type SFR fuel designs in Mk-series loops to produce much of foundational transient behavior data for these systems. The TREAT facility was upgraded in numerous ways to enable testing of larger oxide fuel bundles in an upsized sodium loop in order to address further data gaps, but shifts in national research priorities prevented this upgrade project from being fully completed. The major upgrades that were realized included a larger building with increased crane capabilities and experiment storage holes, modernization of the automatic reactor control system, and reconfiguration/upgrading of the control rod configuration for the reactor trip system (described earlier). While the upsized sodium loop was never deployed, a special set of new TREAT driver fuel assemblies was also fabricated—using higher uranium loading and Inconel canisters to support higher temperature operation—in an inner converter ring meant to increase the fast neutron flux delivered to the test. These new upgrade driver fuel assemblies remain unused in storage at TREAT to this day.

TREAT was upgraded and maintained in state-of-the-art condition up through the early 1990s. By this time, SPERT, PBF, and LOFT had all ceased operation. TREAT continued to perform work related to SFR metallic fuel until funding was canceled for the Integral Fast Reactor Program in the mid-1990s, causing both TREAT and EBR-II to cease operation. EBR-II was eventually decommissioned, and unique specimens irradiated therein were placed in storage to await future use. However, TREAT's unique, simple design required virtually no maintenance to remain in a safe condition. As a result, electrical power to TREAT's control rod drive systems was simply disconnected to ensure it could not operate, fuel was left in the reactor, and it remained unchanged in this state for approximately 20 years.

Owing to its floorspace, vertical headroom, and authorization as a nuclear facility, TREAT was still used throughout these years for various other nuclear research applications, but the reactor itself was not operated. These efforts required TREAT to remain in active status and maintain its safety basis authorization. Throughout this period, occasional efforts surfaced to champion the resumption of reactor operations at TREAT [14], but none garnered enough momentum to realize this goal. The events of Fukushima Daiichi in 2011, however, gave rise to renewed interest in developing and researching enhanced safety characteristics for nuclear fuels. The U.S. Accident Tolerant Fuels (ATF) program was launched shortly thereafter and, along with the other mission needs that had accumulated over the years, finally justified the resources needed to resume reactor operations at TREAT [15].

The TREAT restart project then followed. The entirety of the TREAT restart project is summarized in a journal special issue in Ref. [16]. Articles from this special issue are referenced throughout this paper as appropriate. The facility was thoroughly characterized and refurbished as needed, with a focus on age-related degradation of systems and components. In some cases, basic industrial equipment in the plant was replaced or repaired, but most of the plant's systems were found in good working order. Key staff previously involved in TREAT operation, many of whom had since retired, rallied to this project to train new staff and transfer knowledge. The facility's safety basis authorization was updated and modernized to reflect new standards and needs [17]. As a testament to the facility's simplicity, the orderly way it was shut down, and the dedication of the restart project staff, TREAT achieved its "second first-criticality" in 2017 [18]—both ahead of schedule and under budget [19].

A few years prior to TREAT's restart, contractor reorganization caused the ANL-W campus, along with its key facilities (i.e., TREAT and HFEF), to come under the same management structure responsible for operating many other key nuclear research assets, including the Advanced Test Reactor (ATR). The resulting national laboratory was termed the Idaho National Laboratory (INL). Upon TREAT's successful restart, INL attained a powerful partnership in research reactor facilities (e.g., a high-flux thermal spectrum material test reactor [ATR], a multipurpose transient test reactor [TREAT], and a sizeable hot cell with abilities to examine and transfer specimens between these reactors [HFEF]) (Figure 9).



Figure 9. Modern-day aerial view of INL's materials and fuels complex. (ATR is just out of view on the left side, ~30 km west of TREAT.)

3. Current efforts and future outlook

Efforts to prepare for transient experiments began shortly after the TREAT restart project commenced. The FMMS detectors were refurbished, and its data acquisition system was replaced with a modern digital system at this time. The FMMS works as fast neutrons born in the experimental fuel specimens travel through the experiment's containment structure, the core's void "slotted" assemblies, and one of several slits in a collimator installed in the reactor's concrete shielding. A fast neutron detector resides at the end of each slit. The slits are arrayed to focus on different axial and transverse locations in the experiment cavity. The FMMS detectors interact with fast neutrons to cause scintillation and luminescence. This phenomenon is proportional to the number of fast neutron interactions, becomes amplified by photomultiplier tubes, and is converted into an electrical signal for high-speed digital data acquisition. This FMMS is able to observe the location of test fuel throughout the duration of the transient. Phenomena such as the expansion, disruption, and meltdown of test fuel can be observed in real time by the FMMS. A cross-section image of the FMMS can be seen in **Figure 10**.

Similarly, the new digital experiment data acquisition and control system (EDACS) was installed. EDACS relies on commercially available equipment and is designed with modularity and expandability to support new instrumentation and control system functions. Dedicated controllers work redundantly with this system to ensure that functions significant to safety are highly reliable (e.g., overtemperature control of electric heaters for heating experiments prior to transient operation). Similarly, wire routing options and facility locations were established for special-purpose signal processing and data acquisition equipment to support special test sensors that do not require integration with EDACS.

In the years preceding its restart, numerous experimenters had expressed interest in using TREAT. The interests of these users encompassed LWR-, SFR-, and NTP-type reactors. A new test system, referred to as the Minimal Activation Retrievable Capsule Holder (MARCH), was designed to fulfill these various research needs shortly after resuming reactor operations. The MARCH system took inspiration from historic package-type experiments by using a stainless-steel containment pipe weldment, inside a sheet metal enclosure, referred to as the Broad

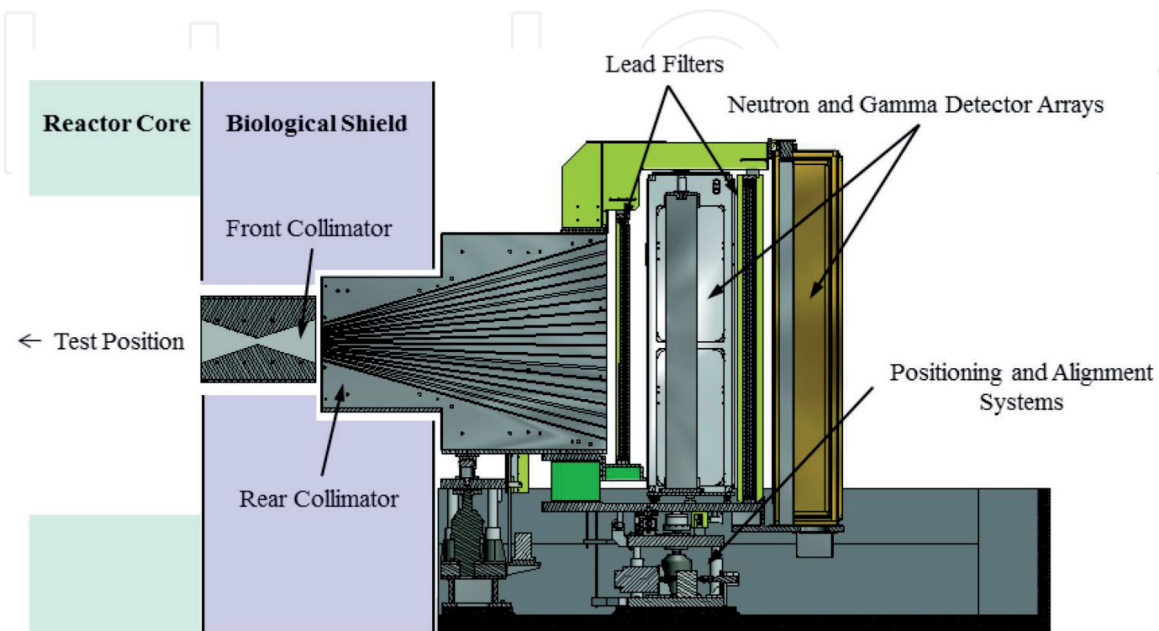

Figure 10. FMMS cross section of collimator/detector locations and the reactor shielding interface [20].

Use Specimen Transient Experiment Rig (BUSTER). BUSTER can be handled, installed, and connected to support leads in the same way as the Mk-series loops. However, the MARCH system departed from the historic approach in that the sealed capsules are placed inside its pipe. Since many of the first fuel technologies tested in TREAT were emerging (e.g., ATF specimens), only fresh fuel specimens were available. Hence, by combining this capsule-in-pipe mechanical layout with capsule materials that do not transmute into significant radioisotopes (principally titanium alloys), the MARCH system enabled fresh fuel capsules to be irradiated, removed from BUSTER on the TREAT working floor by using the storage holes, and shipped for post-transient exams using glovebox facilities, all in a matter of weeks. A detailed characterization of the BUSTER nuclear environment was performed via Monte Carlo neutronics modeling and can be found in [21]. This approach enables BUSTER to function as a reusable device manufactured in accordance with exacting pressure vessel code and quality assurance requirements, whereas capsules are typically treated as consumable hardware with function-specific engineering requirements. This strategy helps reduce costs as well as the design innovation cycles between test series and capsule adaptations.

The inaugural irradiations performed in BUSTER were sponsored by the ATF program and featured LWR rodlets composed of UO₂ pellets in zirconium-alloy cladding. These tests used a helium environment capsule design known as the Separate Effects Test Holder (SETH). These tests focused on quantifying core-to-specimen energy coupling factors, commissioning new experiment support systems such as EDACS, demonstrating use of the FMMS, and assessing the performance of instrumentation in concurrent tests placed in TREAT coolant channel positions [22]. The SETH tests hosted new technologies for world first applications in transient testing, including additively manufactured capsules and multispectral pyrometry. Post-transient exams were performed as intended using a glovebox facility [23], and a second round of capsules were irradiated shortly thereafter on ATF technologies including as U₃Si₂ fuel pellets and silicon carbide composite cladding [24]. The design was adapted to perform power ramp testing on unclad ceramic fuel specimens inside solid metal holders acting as heat sinks to create thermomechanical gradients in order to investigate transient fuel fracture behaviors.

Building on the successes of the SETH series of experiments, three new major capsule categories were created to provide more prototypic specimen boundary conditions. One capsule was created to support new NTP fuel specimen testing in the SIRIUS series of experiments. The SIRIUS capsule design can house hydrogen in its gas environment, as well as support repeated high-temperature irradiations. The SIRIUS capsule has been used to perform repeated power ramps and to measure specimen temperatures ranging from room temperature to well beyond 2000°C in order to simulate NTP engine startup cycles.

Another capsule, termed the Static Environment Rodlet Transient Test Apparatus (SERTTA), was created to house pressurized water environments for reactivity-initiated-accident testing on LWR rodlets. To date, several studies have been performed using SERTTA, including a series of tests focused on the elucidation of in-reactor transient critical heat flux boiling behavior, and aided by a novel electro-impedance sensor able to detect water voiding in real time [25]. The SERTTA capsule was also recently used to test an LWR rodlet previously irradiated in the ATR. This test marked the first modern use of HFEF to assemble TREAT experiments. Tests assembled in HFEF are expected to become prevalent as more previously irradiated specimens become available for end-of-life fuel safety testing.

A new sodium capsule, referred to as the Temperature Heat-Sink Overpower Response (THOR) capsule, was very recently designed and underwent commissioning tests in TREAT. THOR's key feature is a thick-walled metal heat sink

surrounding the specimen. Embedded electrical heaters liquify sodium between the heat sink and test pin cladding prior to transient operation. The liquid sodium enables tight thermal coupling between the pin and heatsink. Working in concert with TREAT's flexible transient power-shaping capability, THOR can simulate transient overpower temperature responses in test pins. THOR can house up to a single full-length EBR-II rod and is currently being prepared for a test series using legacy rods irradiated in EBR-II that were retained for many decades for this very purpose. See **Figure 11** for an overview of the test capsules currently used in the MARCH system at TREAT.

As of 2021, TREAT offers a variety of experiment capabilities and capsules for testing fuel specimens in water, liquid metal, inert gas, and NTP reactor environments. As the only remaining U.S. transient test reactor with significant fuel testing capabilities, TREAT's mission in the modern era remains as diverse as ever. Still, TREAT and its supporting infrastructure are not yet as capable as they were in the past, especially considering that TREAT must now absorb missions that would historically have been addressed by other reactors. This need is particularly important for test devices able to house larger specimens/bundles and actively manipulate thermal hydraulic conditions. For this reason, a new enlarged version of BUSTER (i.e., Big-BUSTER) has been engineered and slated for deployment in TREAT in 2022. Big-BUSTER allows for test devices up to 20 cm in diameter (as opposed to the 6 cm

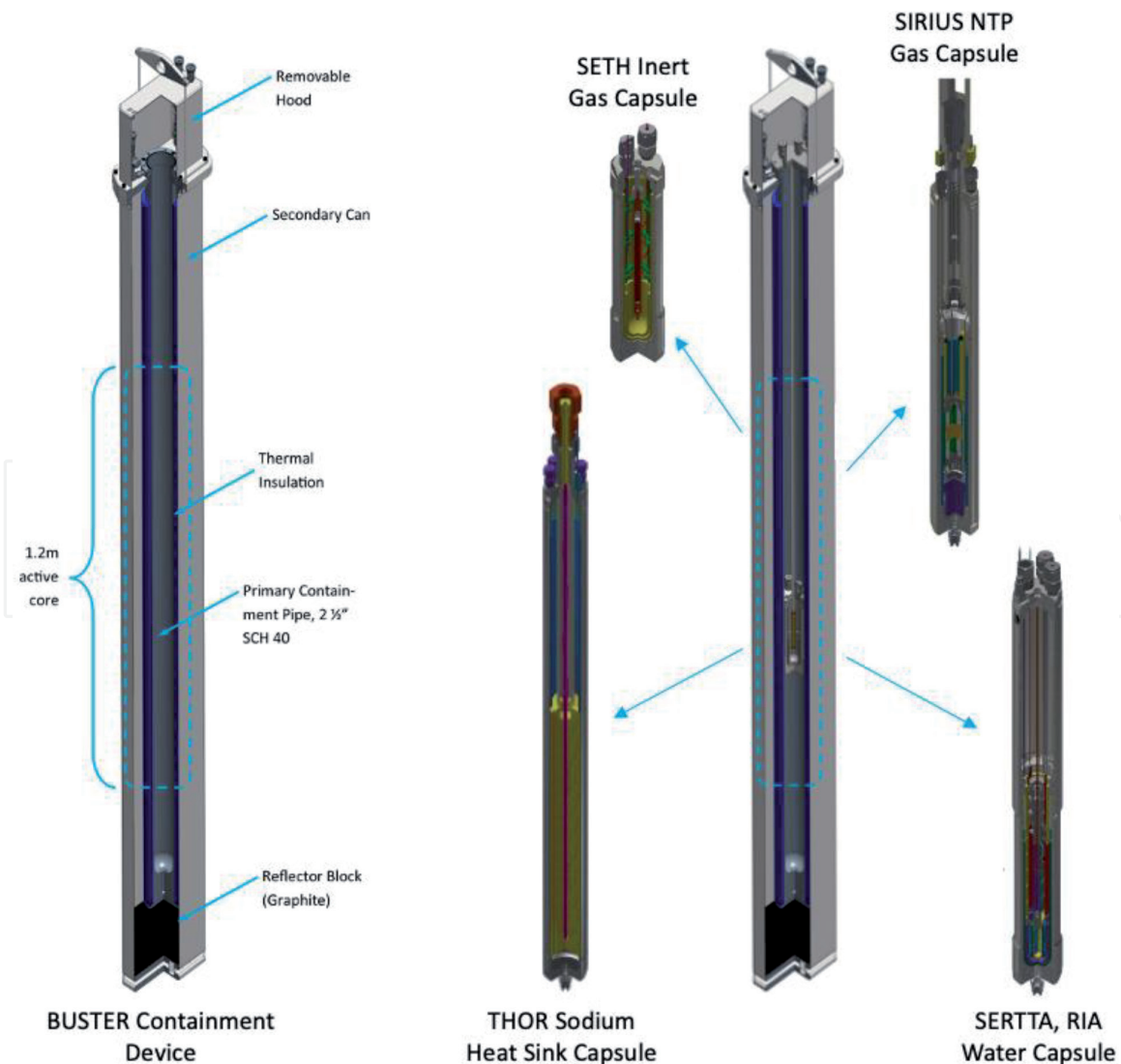

Figure 11.
 Overview of MARCH system and experiment capsules used to date.

available in BUSTER), and is constructed from a zirconium alloy to afford increased neutron flux to the test device.

Currently, Big-BUSTER is planned to house an enhanced pressurized water capsule. This capsule is based on a design originally intended to fit in BUSTER with a water blowdown tank to simulate LWR loss-of-coolant accidents [26] but enlarged and adapted to Big-BUSTER for larger test rods. Hot-cell-based equipment is currently under development to enable full-length LWR rods to be cropped, rewelded/pressurized, and outfitted with instrumentation to support such tests. The historic Mk-series sodium loop was also updated to feature modern components and adapted to fit within Big-BUSTER. This new sodium loop will be used to irradiate SFR specimens and small bundles, including longer pins historically irradiated in the now-decommissioned Fast Flux Test Facility. These pins were shipped to INL decades ago and retained for many years to address transient data needs. Other test devices currently under development involve plans to use Big-BUSTER for enhanced test environment simulation. Notable projects planned for deployment include a flowing hydrogen loop for testing advanced NTP fuels, and a helium gas-cooled device for testing microreactor and other gas-cooled reactor technologies. Based on this trajectory, TREAT is expected to continue expanding its capabilities and missions to likely become the longest lived and most versatile transient test reactor ever constructed.

IntechOpen

Author details

Nicolas Woolstenhulme
Idaho National Laboratory, Idaho Falls, Idaho, United States

*Address all correspondence to: nicolas.woolstenhulme@inl.gov

IntechOpen

© 2021 The Author(s). Licensee IntechOpen. This chapter is distributed under the terms of the Creative Commons Attribution License (<http://creativecommons.org/licenses/by/3.0>), which permits unrestricted use, distribution, and reproduction in any medium, provided the original work is properly cited. 

References

- [1] TREAT History. Available from: <https://transient.inl.gov/SitePages/TREAT%20History.aspx> [Accessed: September 25, 2021]
- [2] Mcfarlane DR, Freund GA, Boland JF. Hazards Summary Report on the Transient Reactor Test Facility (TREAT). ANL-5923. 1958
- [3] Freund GA, Iskendarian HP, Okrent D. TREAT a Pulsed Graphite-Moderated Reactor for Kinetics Experiments. In: Proc. 2nd United Nations Int. Conf. on the Peaceful Uses of Atomic Energy; Geneva, Switzerland. Vol. 10. 1958. p. 461
- [4] Handwerk JH, Lied RC. The Manufacture of the Graphite-Urania Fuel Matrix for TREAT. ANL-5963. 1960
- [5] TREAT Baseline Description Document. ANL/RAS-72-73. Argonne National Laboratory; 1972
- [6] Bess JD, Dehart MD. Baseline Assessment of TREAT for Modeling and Analysis Needs. INL/EXT-15-35372. Idaho National Laboratory; 2015
- [7] Holschuh T, Woolstenhulme N, Baker B, Bess J, Davis C, Parry J. Transient reactor test facility advanced transient shapes. Nuclear Technology. 2019;**205**(10):1346-1353
- [8] Bess JD, Woolstenhulme NE, Davis CB, Dusanter LM, Folsom CP, Parry JR, et al. Narrowing transient testing pulse widths to enhance LWR RIA experiment design in the TREAT facility. Annals of Nuclear Energy. 2019;**124**:548-571
- [9] Grund JE, et al. Subassembly Test Program Outline for FY 1969 and 1970, IN-1313, IDO-17277. Idaho Nuclear Corporation; 1969
- [10] Spencer WA, Jensen AM, McCardell RK. Capabilities of the power burst facility. In: Proc. Int. Topl. Mtg. Irradiation Technology; September 28-30, 1982. pp 175-198. Available from: https://link.springer.com/chapter/10.1007%2F978-94-009-7115-8_13
- [11] Modro SM, et al. Review of LOFT Large Break Experiments. NUREG/IA-0028. U.S. Nuclear Regulatory Commission; 1989
- [12] Wright AE, et al. Mark-III integral sodium loop for LMFBR safety experiments in treat. In: Proc. Conf. on Fast, Thermal, and Fusion Reactor Experiments; Salt Lake City, Utah: American Nuclear Society; April 12-15, 1982. Vol. 1. 1982
- [13] Woolstenhulme N, Baker C, Jensen C, Chapman D, Imholte D, Oldham N, et al. Development of irradiation test devices for transient testing. Nuclear Technology. 2019;**205**(10):1251-1265
- [14] Crawford DC, Swanson RW. RIA testing capability of the transient reactor test facility (IAEA-TECDOC--1122). International Atomic Energy Agency (IAEA). 1999. Available from: https://inis.iaea.org/search/search.aspx?orig_q=RN:30057719
- [15] Wachs DM. Transient testing of nuclear fuels and materials in the United States. Journal of the Minerals Metals and Materials Society. 2012;**64**(12):1396
- [16] Special issue on restarting the transient reactor test facility. Nuclear Technology. 2019;**205**:10
- [17] Gerstner DM, Parry JR, Broussard DJ, Moon BL, Laporta AW, Forshee CP, et al. Safety strategy and update of the TREAT facility safety basis. Nuclear Technology. 2019;**205**(10):1266-1289
- [18] Laporta AW. Transient reactor test (TREAT) facility initial approach to

restart criticality following extended standby operation. *Nuclear Technology*. 2019;**205**(10):1290-1301

[19] Heath BK, Cody CRACE. TREAT restart project. *Nuclear Technology*. 2019;**205**(10):1369-1377

[20] Thompson SJ, Johnson JT, Schley RS, Townsend CH, David LC. Preliminary modeling to support the TREAT hodoscope system for fuel motion monitoring. In: Proc. Int. Conf. PHYSOR 2016; Sun Valley, ID; American Nuclear Society; May 1-5, 2016. Available from: https://inldigitallibrary.inl.gov/sites/sti/sti/Sort_8873.pdf

[21] Bess JD, Woolstenhulme NE, Jensen CB, Parry JR, Hill CM. Nuclear characterization of a general-purpose instrumentation and materials testing location in TREAT. *Annals of Nuclear Energy*. 2019;**124**:270-294

[22] Woolstenhulme N, Fleming A, Holschuh T, Jensen C, Kamerman D, Wachs D. Core-to-specimen energy coupling results of the first modern fueled experiments in TREAT. *Annals of Nuclear Energy*. 2020;**140**:107117

[23] Schulthess J, Woolstenhulme N, Craft A, Kane J, Boulton N, Chuirazzi W, et al. Non-Destructive post-irradiation examination results of the first modern fueled experiments in TREAT. *Journal of Nuclear Materials*. 2020;**541**:152442

[24] Kamerman D, Woolstenhulme N, Imholte D, Fleming A, Jensen C, Folsom C, et al. Transient testing of uranium silicide fuel in zircaloy and silicon carbide cladding. *Annals of Nuclear Energy*. 2021;**160**:108410

[25] Armstrong RJ, Folsom CP, Fleming AD, Jensen CB. Results of the CHF-SERTTA in-pile transient boiling experiments at TREAT. In: Proceedings of TopFuel 2021; Santander, Spain: American Nuclear Society; 10/24/2021-10/28/2021. INL/CON-21-64083. 2021.

Available from: <https://www.osti.gov/servlets/purl/1820615>

[26] Woolstenhulme N, Jensen C, Folsom C, Armstrong R, Yoo J, Wachs D. Thermal-hydraulic and engineering evaluations of new LOCA testing methods in TREAT. *Nuclear Technology*. 2021;**207**(5):637-652