



Publication Year	2020
Acceptance in OA @INAF	2021-12-17T11:13:23Z
Title	MAVIS: The adaptive optics module feasibility study
Authors	VIOTTO, VALENTINA; AGAPITO, GUIDO; GREGGIO, DAVIDE; PLANTET, CEDRIC ANTOINE ADRIEN GABRIEL; PINNA, Enrico; et al.
DOI	10.1117/12.2561041
Handle	http://hdl.handle.net/20.500.12386/31242
Journal	PROCEEDINGS OF SPIE
Number	11448

PROCEEDINGS OF SPIE

[SPIDigitalLibrary.org/conference-proceedings-of-spie](https://spiedigitallibrary.org/conference-proceedings-of-spie)

MAVIS: the adaptive optics module feasibility study

Viotto, Valentina, Agapito, Guido, Greggio, Davide, Plantet, Cedric, Pinna, Enrico, et al.

Valentina Viotto, Guido Agapito, Davide Greggio, Cedric Plantet, Enrico Pinna, Matteo Aliverti, Carmelo Arcidiacono, Olivier Beltramo-Martin, Maria Bergomi, Marco Bonaglia, Lorenzo Busoni, Elena Carolo, Simonetta Chinellato, Jesse Cranney, Jacopo Farinato, Thierry Fusco, Gaston Gausachs, Damien Gratadour, Pierre Haguenuer, Demetrio Magrin, Luca Marafatto, Benoit Neichel, Kalyan Radhakrishnan, Stefan Ströbele, Annino Vaccarella, Daniele Vassallo, Simone Esposito, Roberto Ragazzoni, David Brodrick, Francois Rigaut, "MAVIS: the adaptive optics module feasibility study," Proc. SPIE 11448, Adaptive Optics Systems VII, 114480D (13 December 2020); doi: 10.1117/12.2561041

SPIE.

Event: SPIE Astronomical Telescopes + Instrumentation, 2020, Online Only

MAVIS: the adaptive optics module feasibility study

Valentina Viotto^{*ab}, Guido Agapito^{bc}, Davide Greggio^{ab}, Cedric Plantet^{bc}, Enrico Pinna^{bc}, Matteo Aliverti^d, Carmelo Arcidiacono^{ab}, Olivier Beltramo-Martin^e, Maria Bergomi^{ab}, Marco Bonaglia^{bc}, Lorenzo Busoni^{bc}, Elena Carolo^{ab}, Simonetta Chinellato^{abf}, Jesse Cranney^g, Jacopo Farinato^{ab}, Thierry Fusco^e, Gaston Gausachs^g, Damien Gratadour^g, Pierre Haguenaer^h, Demetrio Magrin^{ab}, Luca Marafatto^{ab}, Benoit Neichel^e, Kalyan Radhakrishnan^{ab}, Stefan Ströbele^h, Annino Vaccarella^g, Daniele Vassallo^{ab}, Simone Esposito^{bc}, Roberto Ragazzoni^{abi}, David Brodrick^g, Francois Rigaut^g

^aINAF – Osservatorio Astronomico di Padova, Vicolo dell'Osservatorio 5, 35122, Padova, Italy

^bADONI – ADaptive Optics National laboratory in Italy

^cINAF – Osservatorio Astrofisico di Arcetri, Largo Enrico Fermi 5, 50125, Firenze, Italy

^d INAF - Osservatorio Astronomico di Brera, Via E. Bianchi 46, 23807 Merate, Italy

^eLaboratoire d'Astrophysique de Marseille, 38 Rue Frédéric Joliot Curie, 13013 Marseille, France

^f INAF - Direzione Scientifica, Viale del Parco Mellini 84, 00136 Roma, Italy

^gAAO - Stromlo, RSAA, Australian National University, Cotter Road, Weston, ACT2600, Australia

^hEuropean Southern Observatory, Karl-Schwarzschild Str. 2, 85748 Garching b. München, Germany

ⁱDepartment of Physics and Astronomy, University of Padova, Padova, Italy

ABSTRACT

The Adaptive Optics Module of MAVIS is a self-contained MCAO module, which delivers a corrected FoV to the post-focal scientific instruments, in the visible. The module aims to exploit the full potential of the ESO VLT UT4 Adaptive Optics Facility, which is composed of the high spatial frequency deformable secondary mirror and the laser guide stars launching and control systems. During the MAVIS Phase A, we evaluated, with the support of simulations and analysis at different levels, the main terms of the error budgets aiming at estimating the realistic AOM performance. After introducing the current opto-mechanical design and AO scheme of the AOM, we here present the standard wavefront error budget and the other budgets, including manufacturing, alignment of the module, thermal behavior and non-common path aberrations, together with the contribution of the upstream telescope system.

Keywords: Adaptive Optics, Multi-conjugate Adaptive Optics, Visible, wavefront sensing, error budget

1. INTRODUCTION

MAVIS^[1] is part of the next generation instrumentation suite of the Very Large Telescope. The MAVIS consortium, led by the Australian astronomical observatory (AAO), also includes the Italian national institute for astrophysics (INAF), the Marseille astrophysics laboratory (LAM), in France, and the European Southern Observatory (ESO). The acronym MAVIS stands for “MCAO assisted visible imager and spectrograph”, and it reflects at the same time the basic description of this general purpose^[2] instrument and its modular nature. On one side, MAVIS includes a 30”x30” FoV imager^[3], with a 7mas/pixel scale, equipped with a number of broad and narrow band filters in the visible regime. At the same time, the instrument also carries an integral field unit (IFU) spectrograph^[3], which, in its current baseline, presents four spectral modes ranging from a very high resolution spectra (3”x3”, R~12000), or a larger FoV, but with a lower resolution (6”x6”, R~5000). Both the Science channel instruments are fed with a 30” AO-corrected FoV in the visible, which will be provided by the Adaptive Optics Module (AOM). AOM concept development started some years ago, with the AOF upgrade concept presented in [4], in which the performance improvement of a visible MCAO system on an 8m-class telescope, even if in a partial correction regime (about 20% SR), with respect to a 2.4m ideal space telescope, was highlighted. MAVIS recently underwent its Phase A feasibility study, during which the consortium had the chance to demonstrate the capabilities of the MAVIS current baseline design. In this paper, we present the results of this study, in terms of expected performance, of the AOM. First, we introduce the core top level requirements, driving the design of

the AOM. Then, we briefly present the list of trade-offs performed during Phase A, and we describe the resulting AOM baseline design. Finally, we illustrate the main performance budgets at the current level of detail, also highlighting the next steps and discussing missing contributions and margins.

2. MAVIS AOM-RELATED MAIN PERFORMANCE REQUIREMENTS

The seeds of MAVIS Phase A workflow are represented by the Top Level Requirements (TLRs) that were applicable to the contract between ESO and the consortium. Here we report the main TLRs impacting the AOM design and performance goal.

First of all, MAVIS was required to be modular, a choice that eases the interactions inside the consortium but also allows, in principle, to give up or postpone part of the project, if any problem arises. Additionally, the modular design would also facilitate any future upgrade of the post-focal instrumentation. Then, as being part of the VLT UT4 instrumentation suite, the AO system embedded in MAVIS shall be designed to exploit the possibilities of the already existing adaptive optics facility (AOF, [5]), on board the telescope, including the four laser guide stars (LGS) projecting and stabilizing systems and the deformable secondary mirror (DSM, 1170 actuators), to be used as a ground layer turbulence compensator.

Concerning the output of the AOM, the TLRs call for a 30" corrected FoV with minimal distortion, optimized in the visible (VRI), but with the goal to preserve also the UBz part of the spectrum as available for the post focal instrumentation.

In terms of the AO system conceptual design, the core drivers are the Strehl Ratio (SR) and Sky Coverage requirements, together with the interfaces to the AOF.

The TLRs included two parallel requests in terms of SR, at V-band:

- $SR \geq 10\%$ (goal 15%) for $m_J \approx 8$ TT-stars (class G2);
- $SR \geq 7\%$ for $m_J \approx 15$ (TBC) TT-stars (class G2).

Even if, comparing to other existing AO modules, a 10% SR with bright tip-tilt stars may seem not too hard to achieve, here it is a real challenge, since MAVIS is expected to work in the visible range, possibly to be extended toward the blue. In this waveband, the requirement translates into an overall budget, in terms of residual wavefront error (WFE), of about 130nm, including also non-common path aberrations (NCPA), manufacturing and alignment tolerances, together with the AO correction term. Such a result is challenging to be achieved, especially for a MCAO system, which needs to compensate for a wide FoV, over which the AOM also needs to maintain a given SR uniformity.

At the same time, the Sky Coverage requirement called for a $\geq 7\%$ average SR in V-band in standard atmospheric conditions (see [6] for definition) in at least 50% of the pointings at the Galactic pole. This requirement was analyzed and a change request was released by the consortium, because this was considered not feasible, evaluated the statistics of stars at the South Galactic pole, but also because such a formulation neglected an entire domain of operations, with degraded performance. A criterion on the ensquared energy or the Tip-tilt residual was considered to much better represent real world applications on the faint end. The updated requirement calls for an AO correction leading to an absolute ensquared energy, in V band, of at least 15% within a 50mas square aperture, in at least 50% of random pointings within 10 degrees of the Galactic pole.

3. PHASE A TRADE-OFFS

We here summarize the main trade-offs completed during Phase A by the MAVIS consortium, impacting the AOM design. The outcome of each trade-off is reported in the next Section, presenting the resulting baseline design. The tight residual WFE budget of the AOM, derived from the SR requirements, impacted the design choices of the AO system at several levels.

First of all, the selected LGSs asterism impacts the ability of the system to properly sense the full atmospheric volume, which perturbs the scientific FoV, hence, the tomographic error. We verified, by means of end-to-end simulations, that the difference between 4 and 8 LGSs for the smallest asterism radius allowed by the system (without entering the Science FoV) is such that only 8 LGSs case can meet the requested performance, if the ESO TLR atmospheric profile is considered. Being the four LGS already provided by the AOF not enough, MAVIS project included a work package to

identify a viable solution to split in two the light from each of the laser launcher of the 4LGSF facility of the AOF. Again, on the LGS sensing, a trade-off, based on simulations^[6], identified the best compromise for the number of sub-apertures for each of the WFSs, considering the resulting number of modes which can be measured, the signal to noise ratio and the aliasing term.

Also the DMs configuration required a dedicated trade-off, to consider, on one side, the impact of the number of correctors and conjugation altitudes on the generalized fitting error and, on the other side, the dependency of the high frequency fitting error on the DMs pitch.

The need to keep all the contributors in the bright end WFE budget as low as possible, also drove some other trade-offs choices, such as the ones related to the performance stability. The main example is the de-rotation scheme. MAVIS will sit on the Nasmyth platform of the UT4, which is gravity invariant for different telescope pointings. On the other hand, the AOM optical train will include a number of fundamental planes, which, depending on the selected field de-rotation scheme, may move one with respect to the other. In particular, we need to lock:

- LGS and LGS WFS entrance FoV: this is mandatory and needs to be compensated because the LGS WFS sits on the Nasmyth so, when the telescope moves in elevation, the LGS asterism image rotates at the level of the LGS WFS FoV;
- DMs (DSM and Post-focal DMs) and LGS WFS pupil: for the DSM, the situation is as above. More in general, we may prefer to have each of the DMs fixed with respect to the LGS WFS, which is retrieving the aberration that the DMs will have to compensate for. Anyway, this is not mandatory, since the pupil/metapupils can be numerically de-rotated in the AO control scheme;
- Sky and NGS WFS entrance FoV: this is the apparent sky rotation that every alt-azimuthal telescope experiences. Of course the images of the NGSs shall be fixed on their corresponding WFSs, once the acquisition is completed;
- Sky and Instruments FoV: same as above, for the final science FoV.

All these needs/desiderata have been analyzed, considering the impact of different alternatives on the opto-mechanics stability (number of moving elements, NCPA, quasi-static effects, all contributing to the SR budget), on the AO control (pupils/metapupils numerical de-rotations), and on the astrometric performance. Of course, also other implementation and reliability aspects, together with management issues, have been considered.

The AOM post focal relay design was impacted by the results of all the trade-offs mentioned before, but it also needed its own analysis to select the best optical configuration between a reflective, a refractive and a catadioptric optical design^[7]. This trade-off included considerations on the optical performance, including WFE, meta-pupils quality, NCPA (absolute value and symmetry), distortion, telecentricity and throughput (ranging from the blue – for the science extension- to the NIR part of the spectrum – for the NGS WFS channel). Again, also in this case engineering tasks, such as manufacturability, accessibility of intermediate focal/pupil planes, tolerances, volume, were taken into account, together with management issues.

Finally, on the faint end regime, the Sky Coverage requirement forced the consortium to adopt a no-compromise approach on NGS sensing. Number of NGSs and size of the technical FoV have been selected according to statistical criteria, so to keep the tomographic error under control, improving the limiting magnitude and maximizing the selectable asterisms. At the same time, the need to reach a large Sky Coverage, made us to push as much as possible the throughput and the sensitivity on the NGS WFS channel, impacting the choice of the waveband for the sensing, and of the concept for the truth sensing.

4. AOM BASELINE OPTO-MECHANICAL DESIGN

MAVIS AOM conceptual scheme includes the outcomes of the trade-offs mentioned in Section 3. The modular configuration of MAVIS is also maintained in the AOM, which includes 3 main opto-mechanical sub-modules: the post focal relay (PFR), the LGS WFS and the NGS WFS (Figure 1). The overall AO system is controlled via the RTC, based on COSMIC platform^[8], for which the preliminary prototyping activity already started in Phase A. The control scheme, implemented in end-to-end simulations, is based on tomographic reconstruction and DM projection, pseudo-open loop control (POLC) and split tomography. At the same time, other approaches, like predictive control, are being investigated and provide some performance margin^{[9][10]}. The details of the optical design are reported in [11].

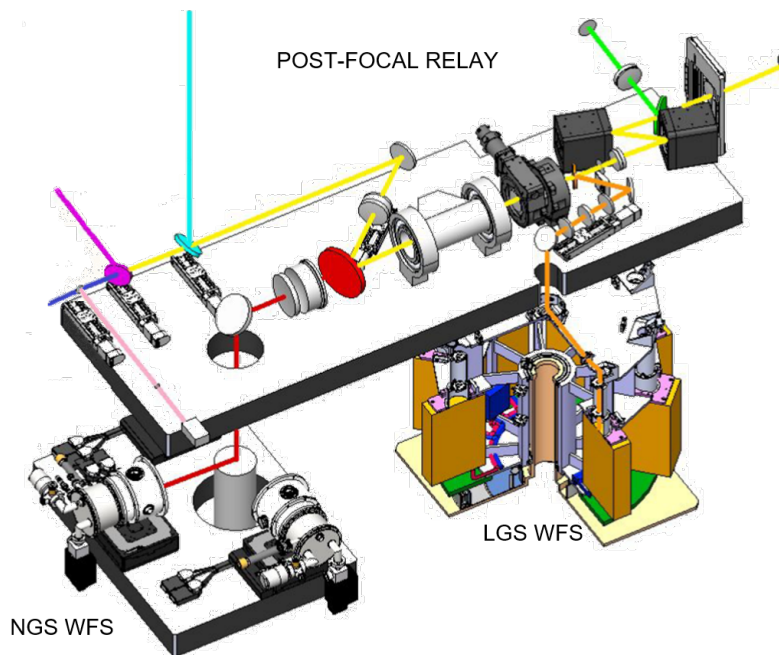

Figure 1 AOM mechanical baseline design (bench structure not included)

4.1 Post Focal Relays

The Post Focal Relays sub-module (Figure 2) collects the light from the UT4 Nasmyth focus A focal plane, provides the input interface for calibration unit (CU), and re-images the meta-pupils, located at 6km and 13.5km onto two ALPAO DMs (pitch 25 and 32cm respectively), which complete, together with UT4 DSM, the set of correctors used by MAVIS to keep the generalized fitting error under control.

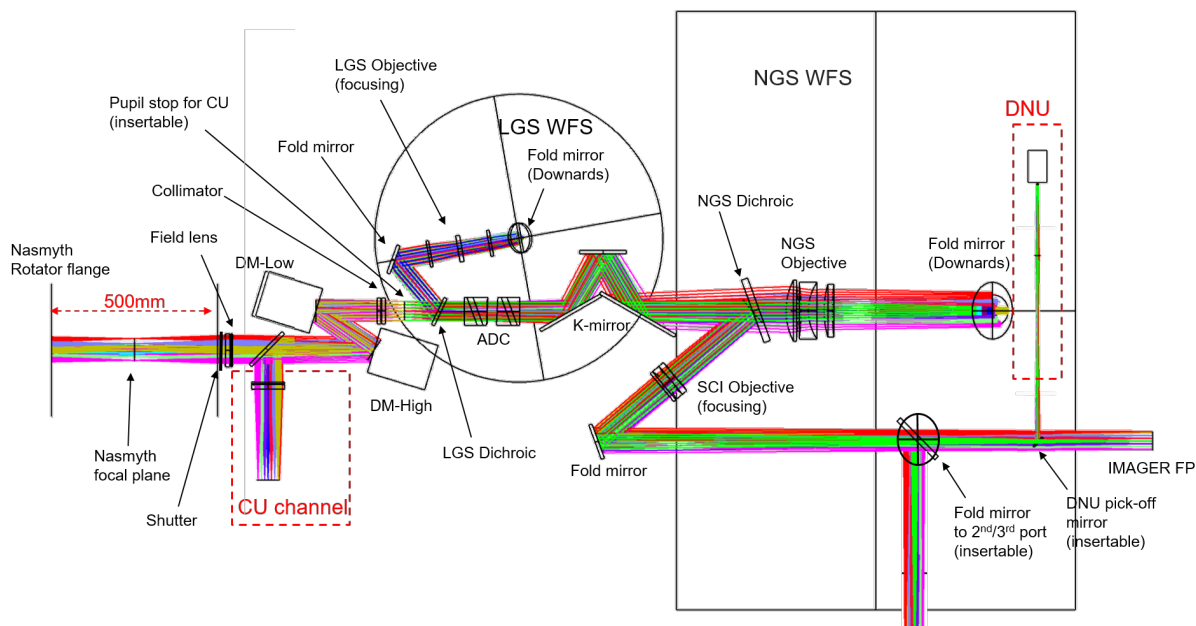

Figure 2 AOM PFR optical baseline design

The Sodium line light is picked-off the main optical train just after the DMs, is focused by a dedicated objective, including means to adapt the focus to the change of the distance of the actual LGSs, when the telescope is moved along its elevation axis, and then is folded downward to the LGS WFS.

The rest of the light is corrected for atmospheric dispersion with a wide band ADC^[12], which is providing impressive nominal results. Then, the PFR provides field de-rotation (NGS + SCI channels), by means of an optical derotator and feeds the NGS WFS with a 2' NIR (J+H) unobstructed FoV at infinity.

In the Science channel, the visible light is focused with a dedicated moving objective, to ease the alignment of the instruments and to compensate for some astigmatism-dependent NCPA, due to chromatism and field curvature in the NGS channel. Finally, the PFR delivers a 30" diameter FoV to the different instruments, providing at least 2 output ports and including means to switch between them.

An additional camera with a smaller FoV for NCPA calibrations and offline diagnostics is also included.

4.2 LGS WFS

The LGS WFS is the MAVIS high order WFS. It includes means to compensate for apparent field rotation, induced by the telescope elevation axis. To do this, the WFS is mounted on a rotating carousel, with a vertical axis, so to maintain the gravity vector fixed with respect to the LGS WFS optical path, and minimize flexures.

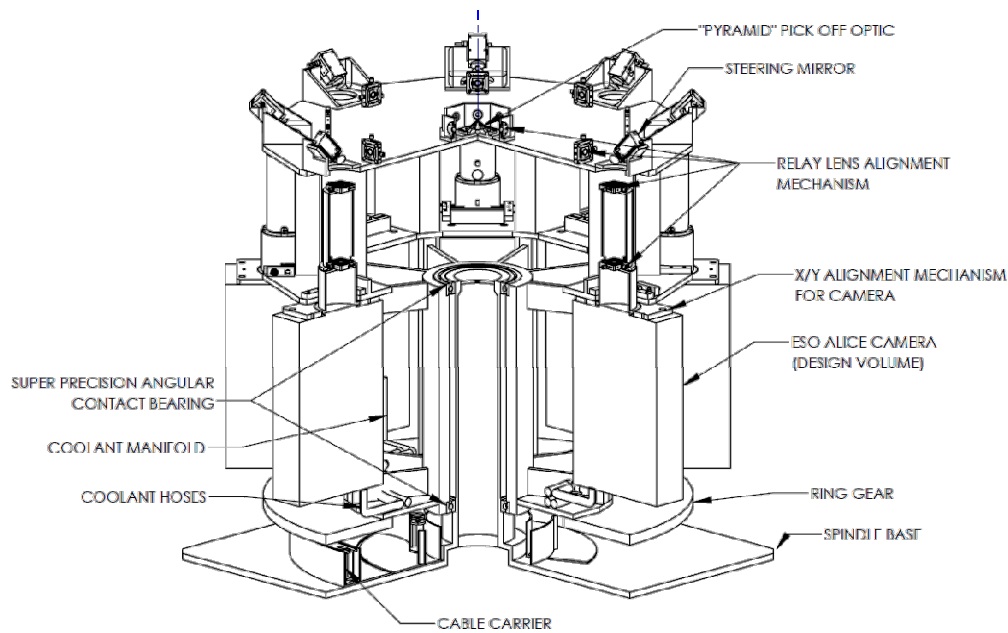

Figure 3 LGS WFS baseline design

The current design assumes eight LGSs, positioned in a 17.5" radius circular asterism. The entrance FoV, stabilized in focus by the PFR, is split into eight areas, corresponding to the different laser source images, by an octagonal reflecting prism, then, on each of the arms, an image steering mirror, located in an image of the pupil, compensate for differential movements between LGSs images produced from a single laser launcher (remember, a laser splitting element will be included in the 4LGSF path, so to double the laser sources provided by the AOF).

In each of the eight arms, the pupil is re-imaged onto the lenslet array of the Shack-Hartmann WFS. Each WFS optics maps a 5" FoV onto a 6x6 pixels spot, with a 40x40 spatial sampling, at the level of the pupil. The baseline cameras are the ALICE systems, currently under design by ESO for the E-ELT. These cameras will include CCD220 detectors.

The combination of the PFR transmissive design, the selected de-rotation scheme and the LGS WFS design gives the advantage that the nominal NCPAs are rotationally symmetric, so that NCPA should not depend on the clocking angle of the LGS constellation (vs science).

4.3 NGS WFS

The NGS WFS is the MAVIS low order WFS. It receives a telecentric unobstructed 2' technical FoV in J+H band from the PFR. The NGS WFS sub-module provides means for stars' acquisition, with a dedicated wide field camera (baseline for the detector is First Light C-RED2), which re-images the incoming FoV and, at the same time, the shadows of the pick-off mirrors, re-directing the light of the selected NGSs to the WFS arms.

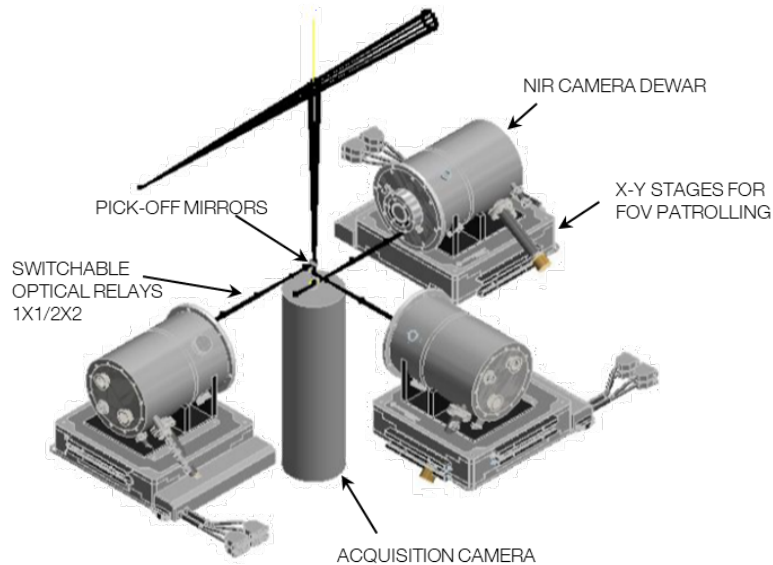

Figure 4 NGS WFS baseline design

The NGS WFS allows to sense up to three NGSs, which can be selected inside the 2' diameter unrestricted patrolling FoV, with the only limitation of the vignetting by POM mechanics (about 6"). This can be achieved because each WFS is mounted on a dedicated 2-axes linear stage, on slightly different levels, along the optical axis, to avoid collision between the pick-off mirrors. Each arm also include a field stop to minimize the sky background.

The NGS WFS provides means to perform, when possible, low order tomographic truth sensing. The current truth sensing strategy foresees each of the WFSs to sample the pupil with 2x2 sup-apertures, providing both tip-tilt and low order truth sensing for each NGS. In the faint NGS regime (threshold still to be quantified) the sampling switches to a single sub-aperture, to maximize the sensitivity to tip-tilt and so the AO system sky coverage (anyway, the noise error in the truth sensing would be higher than the WFE to be measured.) The two switchable optical relays provide different optimized plate scales for the two cases.

5. WFE RESIDUAL ERROR BUDGETS (STREHL RATIO)

Once the Phase A baseline design was frozen, we could analyze it in more details, so to compute a first error budget for the residual WFE after AO correction, to be considered as a starting point for the next phases of the project.

Such a budget should be compared with the SR requirement, presented in Section 2, that is to say 10% SR at V band, for the bright tip-tilt star case. Assuming the Marechal approximation, such a requirement in the visible range (@550nm) translates into a maximum acceptable WFE of 132 nm, which, as already discussed, is a challenging goal.

Being in Phase A, of course, the budget is somewhat simplified with respect to a preliminary design review budget, but it includes all the main expected contributions. The main terms we considered for the moment include the High order and Low Orders AO correction residuals, related to LGS and NGS loops, respectively. These have been computed as the

outcome of end-to-end simulations. In the MAVIS consortium, results from four different simulation tools have been compared, to check the consistency at least at a first order approximation: PASSATA (Montecarlo end-to-end simulations code developed by the INAF-Arcetri team, which gave us the actual values we use in the budget), a second Fourier code (used at LAM), yao and COMPASS (driven by the AAO-Stromlo simulation team). The different tools, after some fine-tuning and considering known differences in the assumptions, are showing good agreement.

In addition to that, we included in the budget two NCPA terms, obtained combining nominal design aberration maps, then manufacturing, alignment and thermal effects that, for the moment, are only first order approximations.

Table 1 AOM WFE residual budget

Error term	Error (nm)
AO residual (HO)	112
AO residual (LO)	55.3
NCPA compensation residual (HO)	10
NCPA compensation residual (LO)	20
Optics manufacturing	15
Optics alignment tolerances	7
Thermal effect	1
TOTAL	127.5

In the next Sections, we report the assumptions behind the results shown in Table 1.

5.1 AO high orders budget

The High Orders residual budget includes the modes controlled by LGS WFS measurements, that is to say, all the modes except tip-tilt, defocus and quadratic plate-scale modes. Some more details on the assumptions and the concept of the simulations used to retrieve the values in the budget are reported in [6]. Since, in this paper, we are interested in identifying how the design and the budget are combined, we can say, simplifying the actual situation, that each of the terms contributing to the HO budgets is linked to one (or more) design choice, reported in the previous Section. Table 2 summarizes the considered items in the budget:

- Fitting error, that includes:
 - the high frequencies fitting error, due the uncorrected spatial frequencies over the Nyquist sampling of the Deformable Secondary Mirror (DM with the smaller projected pitch).
 - the generalized fitting error, due to the limited number of DMs and link to the selected conjugation altitudes, which prevent the system to be able to perfectly compensate the phase perturbations, which are spread in the full altitude of the atmosphere.
- Tomographic error, which is related to the parameters of the LGS asterism, that define how the system can sense and reconstruct the atmospheric volume.
- Signal-to-noise ratio of the WFS measurement, that will be the result of the trade-off between the flux per sub-aperture we can receive and the number of modes we aim to reconstruct.
- Temporal error, related to the evolution of the turbulence and the delay of the correction.
- Aliasing error, linked to the maximum spatial frequency that the WFSs can sense.
- Contribution due to truncation of the LGS spot inside the SH WFS, which will be linked also to the single aperture FoV.
- LGS jitter, that we receive as an input.

Table 2 High order WFE budget

Error term	Error (nm)
HF fitting error	65.3
Generalized fitting error	30.1
Tomographic error	47.6
Measurement noise	40.6
Temporal error	34.7
Aliasing error	40.1
Sodium elongation/truncation	23.6
LGS jitter	6.1
TOTAL	112

5.2 AO low orders budget

The overall WFE budget includes the residual indetermination in the LO modes, which are controlled by NGS WFS measurements, to cope with the LGS tip-tilt indetermination and spot truncation issues. Also in this case, more details on the assumptions and the concept of the simulations used to retrieve the values in the budget are reported in [6]. Table 3 summarizes the considered items in the AO low orders budget. The considered error terms are analogous to some of the ones included in the HO budget:

- Tomographic error, which, this time, is related to the NGS number and positions, is computed for a reasonable asterism (the “best” asterism would give an error of 25nm, instead);
- Measurement noise error. In this case, if we considered the bright end, as in the SR requirement, the measurement noise error would be approximated to 0. Instead, here we include the impact of a 15mag star, to be conservative;
- Temporal error, computed as difference between simulations with and without wind;
- Wind shake vibrations residual, computed analytically.

Table 3 Low order WFE budget

Error term	Error (nm)
Tomographic error	38.8
Measurement noise	26
Temporal error	29.2
Wind shake/vibrations	5.5
TOTAL	55.3

5.3 NCPA

In MAVIS AOM, NCPA are minimized by design. This goal drove some of the main conceptual choices in the overall AOM design, described in Section 3. First of all, in the PFR, the non-common path is kept compact and it includes a minimum number of optical elements. At the same time, as we already mentioned, not only the system sits on the Nasmyth platform, but the LGS FoV de-rotation scheme is such that the LGS WFS always experience the same gravity vector. Moreover, the selection of the refractive design over a reflective one, based on OAPs, allows to have all the powered optics axisymmetric, which means that, at least nominally, the NCPA are azimuthally preserved in the FoV. An

additional effect of this choice is that we don't have, at this stage of nominal design considerations, any term related to the field de-rotators, in the NCPA budgets. This is due to the fact that all the nominal design aberrations center-symmetrical with respect to the FoV. E.g. a beam from a given LGS is evolving with the telescope elevation and its footprint onto the optics is moving and rotating. However, such a footprint is located always at the same radial distance from the center of each element. So, the nominal design aberration experienced by the beam doesn't change in amplitude or mode, but rotates with respect to the fixed elements coordinates. The de-rotator, then, rotates the beam footprint projections upward. This means that the nominal design aberration experienced by the beam upstream the de-rotator is stabilized. Downstream the de-rotator, instead, the beam is fixed with respect to the optics, so it experiences a nominal aberration which is not evolving with time. The reasoning doesn't apply to non-symmetric terms, which can arise because of manufacturing and alignment errors, but are separately considered in the budget.

The current NCPA budget only includes nominal aberrations, embedded in the AOM optical design. For this reason, we implicitly make the following assumptions, for the moment (impacts of neglected terms will be included in Phase B):

1. flexures are not included;
2. misalignments between the center of rotation of the K-mirror and ADC and the center of symmetry of the powered optical elements are not included;
3. the nominal aberrations induced by the LGS and NGS WFS internal optical path were not included, as the design was not mature enough. However, these missing aberrations belong to the static part of the budget, which is the one for which we expect better characterization and compensation.

To compensate the missing terms, we decided to apply a very conservative approach to the residuals of the NCPA calibration, for each of the terms. In particular, we assume that:

- 80% of the static and common NCPA can be calibrated;
- 70% of the static but field-dependent or color-dependent NCPA can be calibrated;
- 50% of the dynamic NCPA are calibrated

This approach provides us with a margin for missing terms in the NCPA budgets, also considering that a typical 10% residual could be assumed, at least for some of the terms. At the same time, we also avoided to assume a calibration whose total absolute residual is smaller than 10nm (considered reasonable), for the moment.

Like the AO WFE residuals, we divided the NCPA term in two budgets: high orders and low orders. AOM NCPA HO term results from NCPA between SCI and LGS WFS channels, including a static term, a science field-dependent term and a LGS focus-dependent term. These three terms have been considered separately, especially because different type/level of calibration can be reasonably applied to each of them (see Table 4). The total residual NCPA after calibration resulted to be smaller than 10 nm, so, as anticipated above, it has been increased to 10nm, so to consider it more reliable and provide additional margin.

Table 4 High order NCPA budget.

Contribution	Calibration residual (%)	Error after calibr. (nm)
Static NCPA	20	2.4
Static NCPA (field dependent)	30	2.7
Dynamic NCPA	50	4.1
TOTAL		5.5 → 10

AOM NCPA LO term results from NCPA between SCI and NGS WFS channels, including a static term, a NGS field-dependent term and a NGS chromatism term (see Table 5). The already described approach for calibration estimation is applied.

Table 5 Low order NCPA budget.

Contribution	Calibration residual (%)	Error after calibr. (nm)
Static NCPA	20	1.4
Static NCPA (field dependent)	30	16
Dynamic NCPA	30	27
TOTAL		32
TOTAL (after focus compensation)		20

The resulting NCPA spectrum, divided by Zernike mode, is dominated by:

- a defocus term, mainly due to chromatism (1000-1700nm band) in the NGS WFS channel;
- an astigmatism term, due to off-axis aberration in the wide NGS WFS field of view.

It shall be noticed, however, that the defocus term is NGS-asterism-dependent, so it does not evolve while the AO loop is closed, but can change only if different NGSs are selected in the field. For this reason, the focus offset can be measured at the beginning of the observation and compensated with the dedicated focusing mechanism on the science channel of the PFR. Concerning the astigmatism term, it is strictly field-dependent and repeatable, so it can be calibrated during the AOM commissioning.

5.4 Optics manufacturing

In the manufacturing budget, the WFE due to optics manufacturing tolerances in the Science instruments path is included as a non-compensated term. For this phase estimation, we assumed $\lambda/20$ and $\lambda/30$ tolerances on the peak-to-valley surface quality of the lenses and of the mirrors, respectively. The DMs are not included in this budget, being the pitch and expected residual part of the AO performance simulations. The rms contributions of the optics have been estimated analytically, using a standard analytic approach.

5.5 Optics alignment

Concerning the impact of the optics alignment, a tolerance analysis has been performed in order to assess the sensitivity to misalignment of every optical element. Each element sensitivity has been evaluated versus different metrics, including meta-pupils quality onto the DMs, average WFE RMS for each of the focal planes and maximum distortion of the NGS and SCI focal planes. The computed rms terms have been included in the alignment budget so to be in line with the statistical approach used for the rest of the WFE overall budget.

At the same time, a Montecarlo simulation, in which all the terms can vary at the same time, has been run and the results showed agreement with the sensitivity analysis approach. The resulting total WFE of the alignment budget is 17.9nm, corresponding to a degradation with respect to the nominal design of 7nm (nominal optical quality of the PFR SCI channel is 16.5nm rms). This is included in the budget as a non-compensated term.

5.6 Thermal behavior

The current MAVIS baseline includes a passive thermal enclosure, which is expected to guarantee a stability better than 0.5 °C in a 12h timeslot.

The sensitivity of the AOM optical design to thermal variation has been evaluated through a first order analysis, assuming linear expansion/contraction of the optical bench with a mean CTE and a variation of the following optics parameters with temperature: position, radius of curvature, thickness, and refractive index (according to catalog data).

The main effects of temperature variations are defocus and change of plate scale in the NGS WFS focal plane and in the SCI focal plane. The combination of the two terms is such that they always partially compensate. Summarizing, the identified NCPA which is induced by thermal variation during observation is less than 1nm of defocus and 0.0035% of plate scale, considering a 0.5 °C variation, which can be considered a worst case, for this stage of analysis. Even if these

values are small and can be considered as encouraging, we shall not forget that this first order analysis lacks the contribution of the hotspots we expect to have on the bench (e.g. the DMs themselves).

6. WFE RESIDUAL ERROR BUDGETS (SKY COVERAGE)

As reported in Section 2, the original TLR sky coverage requirement asked for 7% of SR at V band, (143 nm RMS), on 50% of the sky (at the South Galactic Pole). As already reported, after full analysis, this TLR was proven not to be reachable. At the same time, a discussion in the Science team pushed to revise this requirement asking for a criterion for sky coverage that could better express how widely the system is applicable, also considering larger degradation of the performance, as long as the improvement allows to provide a correction which is appropriate for many MAVIS Science cases. That's why, in the technical Specifications of MAVIS, we agreed to have the sky coverage expressed in terms of ensquared energy instead of SR. As mentioned in Section 2, this ended up to be 15% EE within a 50mas aperture in 50% of the pointings in the Galactic pole area. For comparison, a bright-end V-band MAVIS point spread function, with SR~15%, gives a EE of ~25%.

Table 6 Jitter budget breakdown

Error term	Error (mas)
Tomographic error	18
Measurement noise	12
Wind shake/vibrations	12
TOTAL	25

Table 1 reports the jitter budget breakdown, obtain from the sky coverage analysis, whose details are given in [6], for 50% of the pointings at galactic south pole. The total jitter is relatively large because most of the NGSs available are faint ($H \leq 19$) and far from the science field. The total of 25mas in jitter would correspond to about 18% ensquared energy within 50 mas in 50% of the sky at the South Galactic Pole.

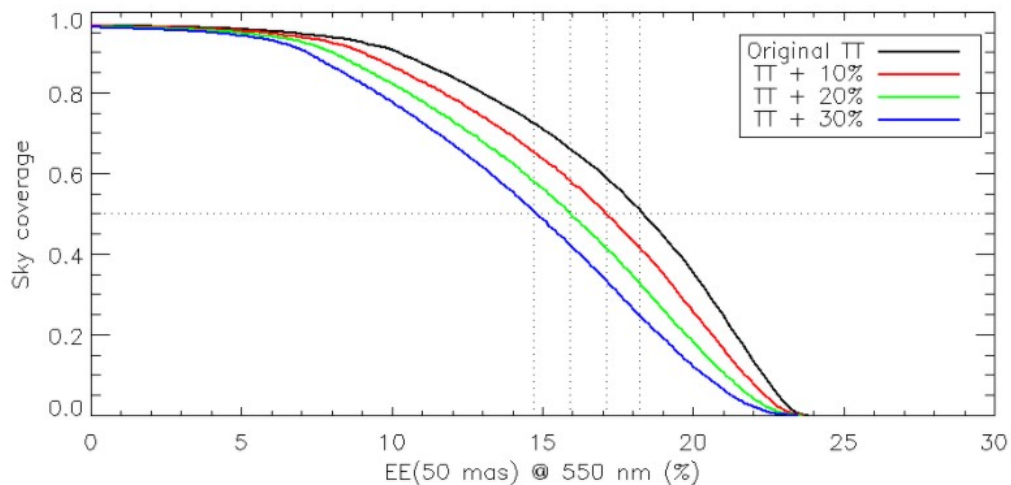

Figure 5 Decrease in the sky coverage performance, as a function of the ensquared energy, for different jitter assumptions. The original TT curve (black) corresponds to the current jitter budget.

Anyway, being in Phase A we need some margin, which is shown in Figure 5. To get to the requirement limit we can accept a jitter about 30% higher than the one computed in this phase.

7. CONCLUSION

MAVIS, the next to come imager and spectrograph for the VLT UT4, recently underwent its Phase A feasibility study. The baseline design of the adaptive optics module, which serves both the post focal instruments, was finalized after a number of trade-off to identify the best solution, even if, in some cases, the consortium followed a no-compromise approach. The main Phase A TLRs, directly related to the AOM design and performance, as presented in Section 2, are fulfilled by the current baseline, described in Section 4.

In particular, for what concerns the SR requirements, a dedicated budget has been presented and the results show compliance to the requirements. Being in Phase A, some minor contributors are still missing, but we still maintain some margin: we computed the residual WFE of the AO LO term for 15mag NGSs when computing the LO residual WFE, even if bright end was assumed in the requirement, and we followed a very conservative approach for what concerns the evaluation of possible NCPA characterization and compensation.

On the Sky Coverage, instead, the original TLR resulted to be statistically unfeasible, and a new formulation for the requirement was proposed, also to cover a larger variety of science cases. The current AOM design and concept shows compliance also to this new requirement, with some margin that will probably be useful at a later stage, when a more complete budget will be realized.

REFERENCES

- [1] Rigaut, F. et al., "MAVIS conceptual design," 11447-332, in these proceedings
- [2] McDermid, R., Cresci, G., Rigaut, F., Bouret, J.-C., De Sinvs, G., Gullieuszik, M., Magrini, L., Mendel, J. T. , Antonucci, S., Bono, G., Kamath, D., Monty, S., Baumgardt, H., Cortese, L., Fisher, D., Mannucci, F., Migliorini, F., Migliorini, A., Sweet, S., Vanzella, E., Zibetti, S., and other contributors, "Phase A Science case for MAVIS – The Multi-conjugate Adaptive Optics Visible Imager-Spectrograph for the VLT Adaptive Optics Facility," in arXiv.org, <https://arxiv.org/abs/2009.09242>, (2020).
- [3] Ellis, S. et al., "MAVIS: science case, imager, and spectrograph," 11447-285, in these proceedings
- [4] Esposito, S., Agapito, G., Bonaglia, M., Busoni, L., Fusco, T., Neichel, B., Spanò, P., Bono, G., and Vernet, J., "AOF upgrade for VLT UT4: an 8m class HST from ground," in SPIE proceedings, 9909, 99093U, (2016).
- [5] Madec P.-Y., Kolb, J., Oberti, S., Paufique, J., La Penna, P., Hackenberg, W., Kuntschner, H., Argomedo, J., Kiekebusch, M., Donaldson, R., Suarez, M., and Arsenault, R., "Adaptive Optics Facility: control strategy and first on-sky results of the acquisition sequence," Proceedings of SPIE, 9909, 99090Z, (2016).
- [6] Agapito, G. et al., "MAVIS: system modelling and performance prediction," 11448-103, in these proceedings
- [7] Greggio, D., Di Filippo, S., Magrin, D., Schwab, C., Viotto, V., Busoni, L., Esposito, S., Ragazzoni, R., Fusco, T., Neichel, B., Pinna, E., Rigaut, F., Arcidiacono, C., Bergomi, M., Biondi, F., Chinellato, S., Farinato, J., Marafatto, L., Portaluri, E., Santhakumari, K.K.R., and Vassallo, D., "Optical design trade-off study for the AO module of MAVIS," in AO4ELT6 proceedings, (2019).
- [8] Gratadour, D. et al., "MAVIS Real-Time Control system," 11448-144, in these proceedings
- [9] Cranney, J. et al., "MAVIS Predictive Control in Learn and Apply Framework," 11448-143, in these proceedings
- [10] Zhang, H. et al., "MAVIS Learn and Apply application and performance analysis," 11448-93, in these proceedings
- [11] Greggio, D. et al., "MAVIS Adaptive Optics Module optical design," 11448-280, in these proceedings
- [12] Greggio, D. et al., "Optical design of a broadband atmospheric dispersion corrector for MAVIS," 11447-263, in these proceedings