



Publication Year	2018
Acceptance in OA @INAF	2020-11-13T15:02:47Z
Title	Calibration of the IXPE instrument
Authors	MULERI, FABIO; LEFEVRE, CARLO; PIAZZOLLA, RAFFAELE; MORBIDINI, Alfredo; AMICI, FABRIZIO; et al.
DOI	10.1117/12.2312203
Handle	http://hdl.handle.net/20.500.12386/28327
Series	PROCEEDINGS OF SPIE
Number	10699

PROCEEDINGS OF SPIE

[SPIDigitalLibrary.org/conference-proceedings-of-spie](https://spiedigitallibrary.org/conference-proceedings-of-spie)

Calibration of the IXPE instrument

Fabio Muleri, Carlo Lefevre, Raffaele Piazzolla, Alfredo Morbidini, Fabrizio Amici, et al.

Fabio Muleri, Carlo Lefevre, Raffaele Piazzolla, Alfredo Morbidini, Fabrizio Amici, Primo Attina, Mauro Centrone, Ettore Del Monte, Sergio Di Cosimo, Giuseppe Di Persio, Yuri Evangelista, Sergio Fabiani, Riccardo Ferrazzoli, Pasqualino Loffredo, Luca Maiolo, Francesco Maita, Leandra Primicino, John Rankin, Alda Rubini, Francesco Santoli, Paolo Soffitta, Antonino Tobia, Alessia Tortosa, Alessio Trois, "Calibration of the IXPE instrument," Proc. SPIE 10699, Space Telescopes and Instrumentation 2018: Ultraviolet to Gamma Ray, 106995C (6 July 2018); doi: 10.1117/12.2312203

SPIE.

Event: SPIE Astronomical Telescopes + Instrumentation, 2018, Austin, Texas, United States

Calibration of the IXPE instrument

Fabio Muleri^a, Carlo Lefevre^a, Raffaele Piazzolla^a, Alfredo Morbidini^a, Fabrizio Amici^a, Primo Attiná^a, Mauro Centrone^d, Ettore Del Monte^a, Sergio Di Cosimo^a, Giuseppe Di Persio^a, Yuri Evangelista^a, Sergio Fabiani^a, Riccardo Ferrazzoli^a, Pasqualino Loffredo^a, Luca Maiolo^c, Francesco Maita^c, Leandra Primicino^a, John Rankin^a, Alda Rubini^a, Francesco Santoli^a, Paolo Soffitta^a, Antonino Tobia^a, Alessia Tortosa^a, Alessio Trois^b, and on behalf of the IXPE team

^aINAF-IAPS, Via del Fosso del Cavaliere 100, I-00133 Roma, Italy

^bINAF-OAC Via della Scienza 5 - 09047 Selargius (Cagliari), Italy

^cCNR-IMM via del Fosso del Cavaliere 100, I-00133, Roma, Italy

^dINAF-OAR, Via di Frascati, 33, I-00040 Monte Porzio Catone, Italy

ABSTRACT

IXPE scientific payload comprises of three telescopes, each composed of a mirror and a photoelectric polarimeter based on the Gas Pixel Detector design. The three focal plane detectors, together with the unit which interfaces them to the spacecraft, are named IXPE *Instrument* and they will be built and calibrated in Italy; in this proceeding, we will present how IXPE Instrument will be calibrated, both on-ground and in-flight. The Instrument Calibration Equipment is being finalized at INAF-IAPS in Rome (Italy) to produce both polarized and unpolarized radiation, with a precise knowledge of direction, position, energy and polarization state of the incident beam. In flight, a set of four calibration sources based on radioactive material and mounted on a filter and calibration wheel will allow for the periodic calibration of all of the three IXPE focal plane detectors independently. A highly polarized source and an unpolarized one will be used to monitor the response to polarization; the remaining two will be used to calibrate the gain through the entire lifetime of the mission.

Keywords: Imaging X-ray Polarimetry Explorer, calibration, on-ground, in-flight

1. INTRODUCTION

The Imaging X-ray Polarimetry Explorer (IXPE, see O'Dell et al. in this same volume¹) will be launched in April 2021 carrying on-board the first instrument dedicated to X-ray polarimetry in decades. The mission, selected in the context of the NASA Astrophysics Small Explorer (SMEX) program in January 2017, is a collaboration with the Italian Space Agency (ASI) which will provide with INAF and INFN the focal plane instrumentation. This comprises three flight *Detection Units* (DUs), plus a spare, and a *Detector Service Unit* (DSU). The former, built by INFN-Pisa, is the unit which contains the device sensitive to X-ray polarization, which is based on the photoelectric effect and on the Gas Pixel Detector design developed in Italy for nearly 20 years.²⁻⁴ The DU also includes a *Filter and Calibration Wheel* (FCW), which hosts filters for special observations and four calibration sources to monitor GPD performance in flight, as described in Section 3. The DSU contains the electronics required to manage the DUs and interface them to the spacecraft.

DUs will be calibrated and functionally tested in Italy, at INAF-IAPS, before delivery to NASA Marshall Space Flight Center (NASA-MSFC), where they will be calibrated together with the mirror built by MSFC for the telescope calibration. While the latter will be dedicated to an end-to-end calibration of the IXPE instrumentation before integration on the spacecraft, DU calibration will feature an extensively characterization of the scientific performance of the GPD. The equipment which will be used at this aim are collectively named *Instrument Calibration Equipment* (ICE) and they will be described in Section 2.1.

Further author information: (Send correspondence to Fabio Muleri)

Fabio Muleri: E-mail: fabio.muleri@iaps.inaf.it, Telephone: +39-0649934565

2. INSTRUMENT ON-GROUND CALIBRATIONS

Instrument calibration will be devoted to:

- measure the modulation factor as a function of energy to better than 1% of its value; the same measurements will allow also deriving how the energy resolution varies with energy. Measurements will be carried out with a beam of collimated, polarized and monochromatic photons at different energies. The spot will be about 0.4 mm, that is, comparable to the spot from a real X-ray telescope. For a few reference energies the measurements will be repeated on a grid of positions to map all the sensitive area of the GPD, repeating periodically a measurement in a reference position for checking possible intrinsic variations of the beam. The procedure is already in use at INAF-IAPS for the calibration of GPD prototypes.
- measure the spatial resolution as a function of energy. Measurements will be carried out with a collimated, pencil beam of tens μm size, that is much smaller than the GPD spatial resolution, on a grid of positions and at a few energies. Also in this case, the procedure was already used with the GPD.⁵
- check the absence of a significant spurious polarization to $\lesssim 0.1\%$. Measurements will be repeated at a few energies in several positions of the sensitive area.
- check the relation between the expected and measured angle of polarization. Measurements with polarized radiation at a few energies will be repeated in the same point of the detector changing the angle of polarization to verify the relation between the expected and the measured value.
- Map the gain. The gain of the Gas Electron Multiplier can change with the position of a factor \pm few tens %.⁶ The gain will be mapped by fully illuminating the GPD with at least two sources at different energies.
- Measure the efficiency. The efficiency of the detector will be measured by means of the comparison of the detected rate with a devices of known efficiency; the measurements will be carried out in one representative point of the detector and repeated at several different energies.

An exemplary list of measurements which will be carried out during Instrument calibration is listed in Table 1. The total time for calibration of each DU is 45 days.

Calibration	Energy (keV)	XY Positions	Angle of polarization
Modulation factor/ Energy resolution	1.7, 2.0, 2.6, 3.7, 4.5, 5.2, 6.4, 8.0, 9.7	2x2	1
Modulation factor/ Energy resolution	2.9, 4.5	5x5+5	1
Spatial resolution	2.3, 4.5, 9.7	3x3+2	1
Spurious modulation	2.3, 3.7, 5.9	3x3+2	1
Angle of polarization	3.7, 4.5	1	12+3
Gain mapping	3.7, 5.9	1	1
Efficiency	3.7, 4.5, 6.4	1	1
Inclined measurement	3.7, 4.5, 6.4, 8.0	1	1
		Total Time	45 days

Table 1. Exemplary calibration plan for Instrument.

2.1 The Instrument Calibration Equipment

The Instrument Calibration Equipment (ICE) comprises the items which are used for Instrument calibration and functional tests. In particular, it includes:

- the X-ray sources used for illuminating the detector. Each source emits X-ray photons at known energy and with known polarization degree and angle. The direction of the beam, the direction of polarization for polarized sources, and its position can be measured with respect to the GPD inside the DU and aligned and moved as necessary.
- the test detectors which are used to characterize the beam before DU calibration and as a reference for specific measurements (e.g., the measurement of quantum efficiency).
- all the electrical and mechanical equipment required to support the DU and the calibration sources, monitor the relevant diagnostic parameters and assure safe operations during calibrations. This includes also the clean environment (class better than 100,000) in which DU will be calibrated.

A drawing of the ICE when the polarized source is mounted is shown in Figure 1. The DU will be mounted in the ICE without the stray-light collimator and the UV filter, to limit the distance between the X-ray source and the GPD and hence air absorption and beam divergence. The DU is placed on the top of a tower (see Figure 2(a)) which allows to:

- move the DU (item 5 in the figure) on the plane orthogonal to the incident beam with an accuracy of $\pm 2 \mu\text{m}$ (over a range of 100 mm) to map the GPD sensitive surface. These two stages (items 4 and 3) are named xdu and ydu .
- rotate the DU on the plane orthogonal to the incident beam with an accuracy of ± 7 arcsec, to test the response at different polarization angle values and to average residual polarization of unpolarized sources, if necessary. This stage (item 2) is named ϵ .
- tip/tilt align the orthogonal direction of the GPD to the incident beam (item 1). Two out of the three feet of the tip/tilt plate (called η_1 and η_2) will be manual micrometers, but one (η_0) will be motorized to carry out automatically measurements with the beam off-axis of a series of known angles, between < 1 degree and about 5 degrees, e.g., to simulate the focusing of X-ray mirror shells.

The X-ray source is mounted on a mechanical support which allows to adjust its position and inclination with respect to the DU (see Figure 2(b)). A manual translation stage (χ , item 8) allows to move the source assembly in three separate positions: (1) calibration with DU; (2) source characterization with test detectors; (3) source set-up and mounting (see Figure 1). The source assembly is fixed when in position with two brakes mounted at its top and bottom ends. A vertical motorized stage (ν , item 6) with range 300 mm and accuracy $\pm 5 \mu\text{m}$ allows to move the source at different heights and minimize the distance of the source to the DU; software and hardware limitations will avoid the source to hit the DU even in case of wrong commanding. Two motorized linear stages (item 7) mounted in XY configuration on the plate of the vertical stage, named xso and $ysso$, allows to move the X-ray source and center the beam on the axis of rotation of DU rotation stage ϵ , to avoid moving the spot while rotating this stage. The uppermost of the XY stages is the mechanical interface for mounting polarized and unpolarized calibration sources on the source assembly.

A cut-out view of the polarized source with Oxford Series 5000 X-ray tube mounted is reported in Figure 3. Polarized photons are produced by means of Bragg diffraction at nearly 45 degrees on different crystals to cover the whole DU energy range, with a design based on the heritage of the calibration facility used at IAPS for GPD calibration for 10 years.⁷ Crystal orientation, which sets the energy, the polarization degree and angle, and the direction of the beam, can be initially adjusted with a manual stage and, once fixed, measured with high accuracy. Crystal holder are designed so that the surface of the crystal is parallel by design to a surface accessible after source integration; the orientation of such a surface is measured with a measurement arm and referred to the GPD orientation by means of the alignment references in the DU. A diaphragm with aperture

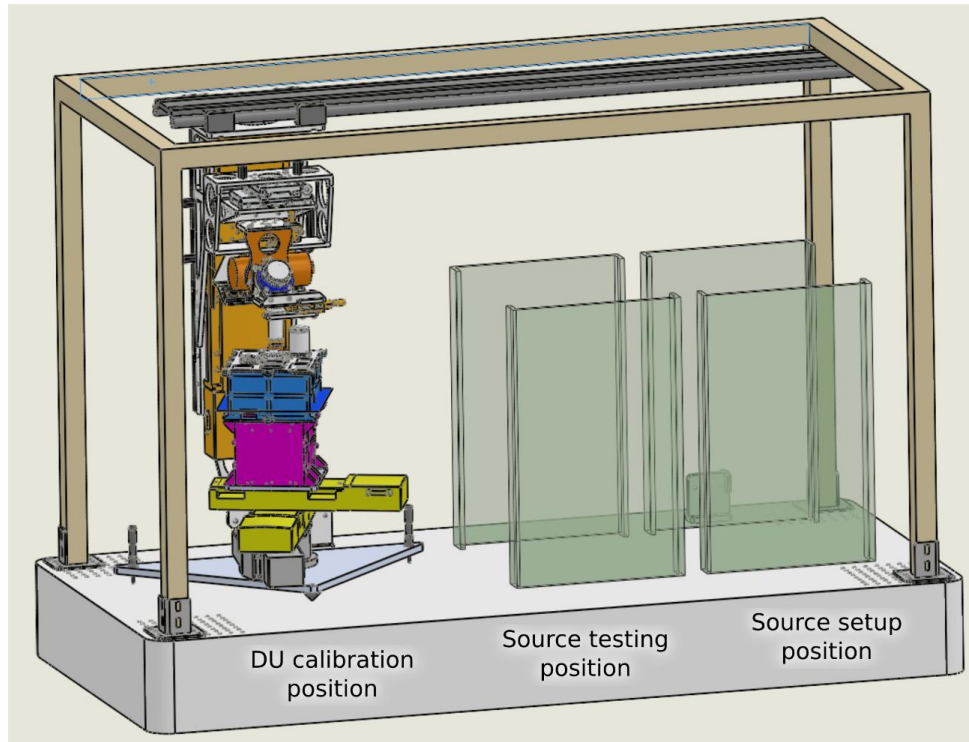

Figure 1. Sketch of the calibration equipment for DU calibration.

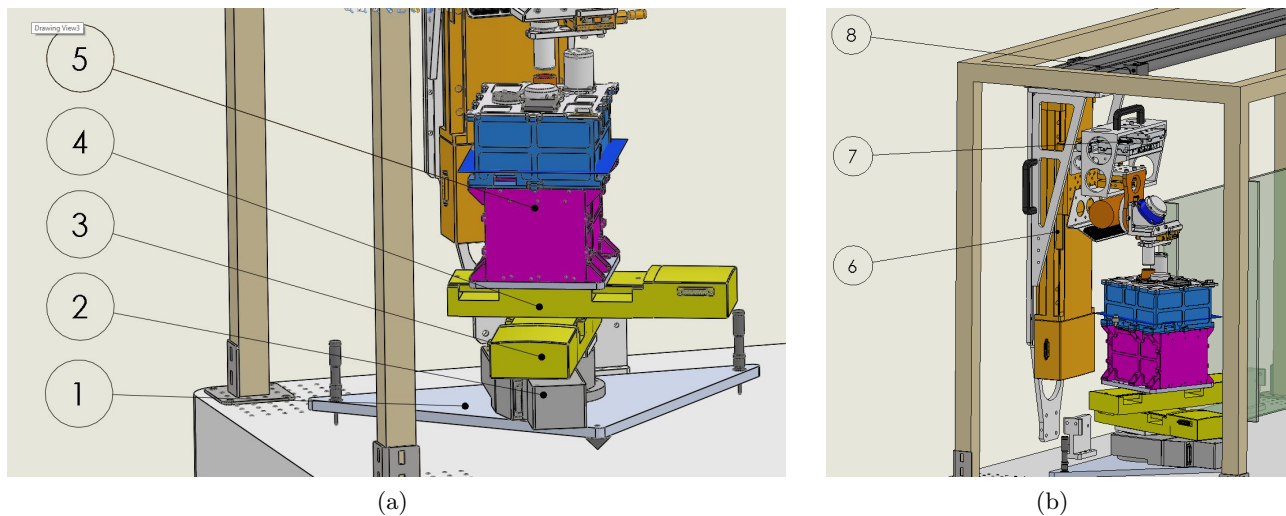

Figure 2. (a) Detailed view of the tower supporting the DU. (b) Overview of the source assembly.

from 2 mm to 25 μm will be mounted at the end of the source extension which will avoid mechanical interference with DU parts extending from the lid. Diaphragm position will be manually adjustable to center the spot diffracted by the crystal, with a procedure based on the imaging of the X-ray beam with test detector and an alignment diaphragm. Inner part of the source will be made of brass to reduce scattering of impinging photons, and collimators at capillary plates can be mounted to constrain the direction of incident and diffracted radiation. A tip/tilt stage allows for beam direction adjustment in addition to the DU tip/tilt plate. Inner chamber of the source will be flown with helium to reduce the severe air absorption of X-rays in the IXPE energy range. Helium

will be flown also inside a cylinder mounted on the lid of the DU (item 14 in Figure 4) and extending inside it, to reduce air absorption inside the DU. Helium will not be dispersed inside the DU to avoid discharges from the GPD Titanium top frame, which is at high voltage.

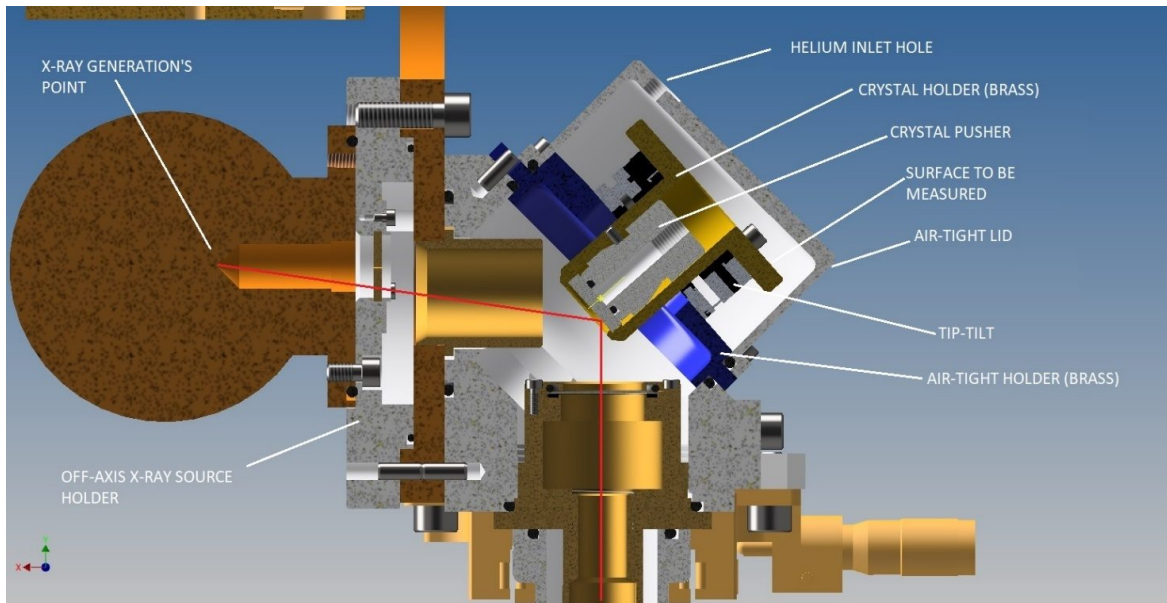

Figure 3. Cross section of the polarized calibration source.

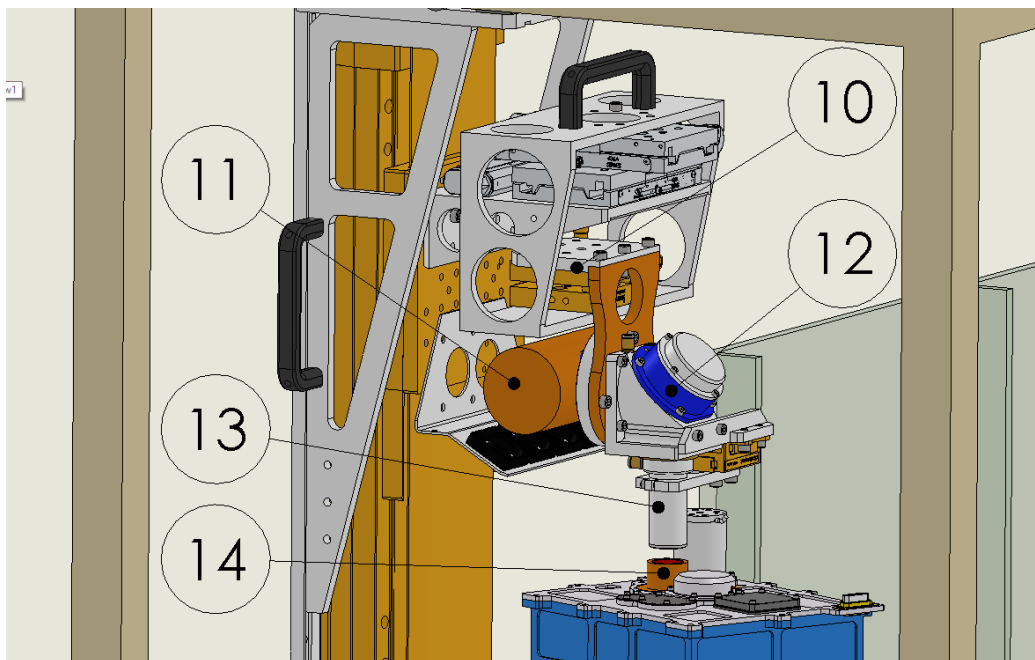

Figure 4. Detailed view of the polarized source assembly.

The polarized source can host also X-ray tubes different from Oxford Series 5000, e.g. Hamamatsu Head-on N7599 series, without disassembling the crystal and the collimator from the source assembly. Moreover, a source, based on the Compton scattering of X-ray photons in a Lithium rod encapsulated in Beryllium, will be

available to generate highly-polarized continuum radiation which is representative of the spectrum of a typical astrophysical source. The list X-ray tubes, crystals and energies available for Instrument calibrations is shown in Table 2.

Energy (keV)	Crystal	X-ray tube
1.7	Ammonium Dihydrogen Phosphate - ADP	Oxford 5000 Series, Titanium, 50 W
2.0	Pentaerythritol - PET	Oxford 5000 Series, Titanium, 50 W
2.3	Rhodium	Oxford 5000 Series, Molybdenum, 50 W
2.6	Graphite	Oxford 5000 Series, Titanium, 50 W
2.7	Germanium (111)	Oxford 5000 Series, Rhodium, 50 W
3.0	Silicon (111)	Oxford 5000 Series, Silver, 50 W
3.7	Aluminum	Head-on Hamamatsu, Calcium, 0.2 W
4.5	Calcium fluorite	Oxford 5000 Series, Titanium, 50 W
5.2	Graphite	Oxford 5000 Series, Titanium, 50 W
6.4	Silicon (100)	Oxford 5000 Series, Iron, 50 W
8.0	Germanium (111)	Oxford 5000 Series, Copper, 50 W Head-on Hamamatsu, Copper, 2.0 W
9.7	Lithium fluoride	Oxford 5000 Series, Gold, 25 W
Continuum	Lithium rod	Oxford 5000 Series, Tungsten, 50 W Head-on Hamamatsu, Tungsten, 2.0 W

Table 2. Energy, crystals and X-ray tubes for the generation of polarized X-rays with the ICE.

The design of unpolarized-source setup with one of the head-on X-ray tubes is shown in Figure 5. The X-ray tube is arranged so that its direct emission illuminates the detector through two diaphragms with aperture between 25 μm and 2 mm. The bottom diaphragm can be aligned with the first and the X-ray spot of the tube with motorized stages. Helium is flown inside the collimator to avoid air absorption. Head-on X-ray tubes are, thanks to symmetry of the emission geometry, sources with a very low intrinsic polarization; for the Calcium head-on X-ray tube, we measured a residual polarization lower than 0.5%. Head-on X-ray tubes with Calcium, Copper and Tungsten anodes are available for IXPE Instrument calibration; Calcium and Copper X-ray tubes have prominent fluorescence lines at 3.7 and 8.0 keV, respectively, whereas Tungsten X-ray tube does not have fluorescence lines between 2 and 8 keV. Many Oxford series 5000 X-ray tubes with different anodes will be available for Instrument calibration, but in this case radiation is emitted at about 90 degrees and continuum emission is polarized at about 10-15%. Continuum emission can not be completely removed from fluorescence lines with the spectral capabilities of the detector, and then Oxford 5000-Series X-ray tubes may result not appropriate for the use as unpolarized sources. If this will be confirmed by further tests, a backup solution will be to rotate the DU during the measurement to average the residual polarization.

Testing and characterization of the ICE sources will be carried out with three commercial X-ray detectors: (i) a CCD imager (model Andor iKon-M SY) to measure and map the beam spot and center the diaphragm of polarized source; (ii) a SDD spectrometer (model Amptek FAST SDD) to characterize the spectrum (and hence the polarization) and the counting rate of the beam. This detector will be also used as a reference for the efficiency measurements of the DU efficiency; (iii) a Si-PIN detector (model Amptek XR100CR) as a spare spectrometer.

3. IN-FLIGHT CALIBRATION

Calibration sources are included in the DU to carry out in-flight calibration of the Instrument and monitor changes in performance, if any, during the IXPE lifetime. Variations may be due to changes in environmental conditions or degradation, albeit the latter are supposed to be very small from on-ground activities.⁸ DU calibrations will be performed in orbit with the set of calibration sources mounted on the FCW with the aim of:

- monitoring the modulation factor value of the GPD for monochromatic photons and hence the stability of polarimetric response at two energies;

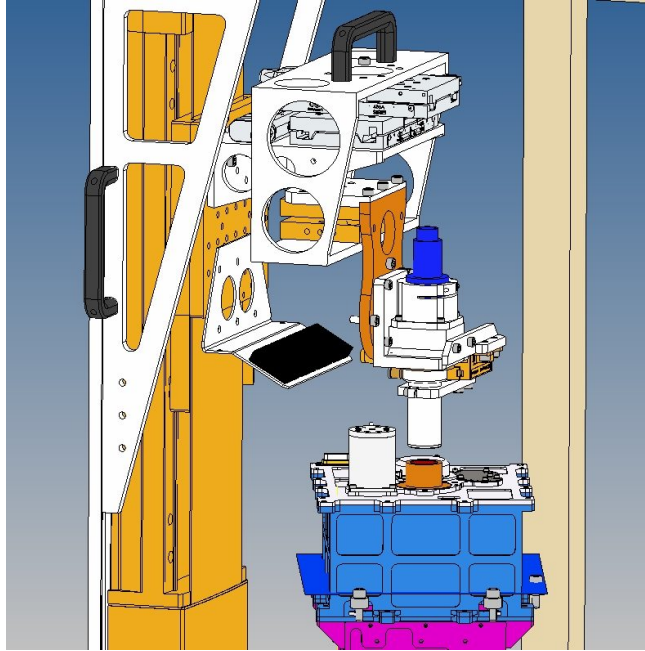

Figure 5. Preliminary design of unpolarized calibration source based on head-on X-ray tubes.

- monitoring the energy resolution of the GPD;
- check for the presence of spurious polarization due to, e.g., any anisotropy in the distribution of the background;
- map and monitor the gain of the GEM and its non-homogeneities.

Calibration sources are hosted on a Filter and Calibration Wheel (FCW) which is included in the DU (see Figure 6). FCW has 7 different positions, which can be alternatively put in front of the GPD. In particular, there are:

- Open position. In this position no filter is put in front of the detector. The open position will be the standard one used for science observations. Only in case the source to observe is expected to be exceptionally bright (flux higher of about 4×10^{-8} erg/cm²/s, or 2 Crab), the use of the gray filter described below will be recommended to reduce and better control the dead time of the observation. The aperture of the open position will be 31.3 mm; this value is derived by the requirement that not obstruction of the field of view shall occur, including the uncertainty in the relative positioning of the DU and of the corresponding mirror after boom deployment or because thermo-elastic deformation of the boom.
- Close position. In this position a black filter, that is, a filter which is opaque to the radiation of interest, is placed in front of the detector. Mechanically, the filter will be a disk of aluminum 3.5 mm thick, which provides a transmission lower than 10^{-5} at 12 keV.
- Gray filter. In this position a filter partially opaque to the radiation to be observed is used. The filter will be made of kapton 75 μ m thick; in this case, the counting rate in the energy range 2-8 keV (or 1-12 keV) for a Crab-like spectrum (power law with index 2) will be reduced of a factor about 4 (or 8).
- Calibration source A (Cal A). This source will produce polarized X-ray photons with precisely-known energy and polarization state, to monitor the modulation factor of the instrument at two energies in the IXPE energy band. A drawing of the source is shown in Figure 7. A single ⁵⁵Fe nuclide is mounted and

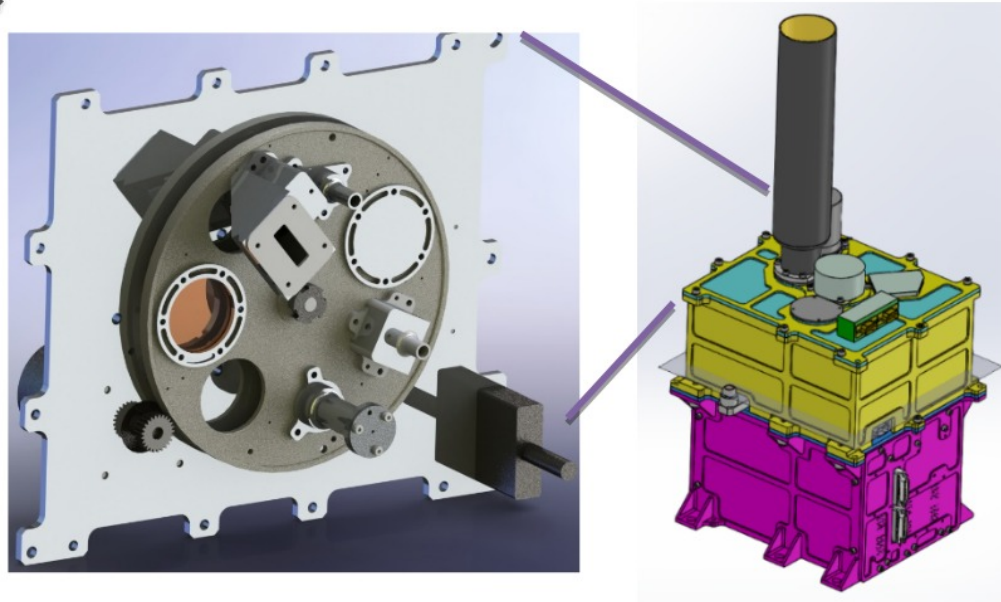

Figure 6. Filter and Calibration Wheel in the IXPE DU.

glued into a T-shaped holder. X-rays from ^{55}Fe at 5.9 keV and 6.5 keV are partially absorbed by a thin silver foil mounted in front of the ^{55}Fe nuclide to produce fluorescence at 3.0 keV and 3.15 keV. Silver foil is $1.6\ \mu\text{m}$ thick and it is deposited between two polyimide foils which are $8\ \mu\text{m}$ (on the side towards the ^{55}Fe) and $2\ \mu\text{m}$. Photons at 3.0 keV and 5.9 keV, collimated with a broad collimator, are diffracted on a graphite mosaic crystal, with FWHM mosaicity of 1.2 deg, at first and second order of diffraction, approximately at the same diffraction angle and hence polarization (see Table 4 -9 for details). A second collimator is used to block stray-light X-rays.

- Calibration source B (Cal B). This source will produce a collimated beam of unpolarized photons, to monitor the absence of a spurious modulation. An exploded view of the source is reported in Figure 8(a). A ^{55}Fe radioactive source (item 4) is glued in a holder (item 3) and screwed in a cylindrical body (item 1). At the other end of the body, a diaphragm with an aperture of 1 mm (item 2) collimate X-rays to produce a spot of about 3 mm on the GPD.
- Calibration source C (Cal C). This source (see Figure 8(b)) will illuminate all the detector sensitive area to map the gain at one energy. This source will be composed of a ^{55}Fe iron radioactive source (item 2), glued in a holder (item 3) which is screwed in a body (item 1). A collimator allows X-ray photons to impinge on the detector sensitive area only when the source is in front of the GPD.
- Calibration source D (Cal D). This source (see Figure 8(c)) will illuminate all the detector sensitive area as Cal C, to map the gain at another energy. Cal D is based on a ^{55}Fe source (item 3), glued in an aluminum holder (item 1) which illuminates a Silicon target (item 4) mounted on a body (item 2) to extract $K\alpha$ fluorescence from Silicon at 1.7 keV, which impinges on the detector. It is worth noting that the design is such that X-ray photons from ^{55}Fe can not directly impinge on the GPD sensitive area to avoid detector saturation.

All calibration sources inside the FCW contains a ^{55}Fe nuclide, whose activity naturally decays with half time of 2.7 years. To minimize the activity of the on-board nuclides for achieving the required counting rate, all the radioactive nuclides will be inserted in the Instrument as late as possible in the integration flow. This will be done during Instrument integration on the spacecraft. Replacement of the radioactive nuclides will be

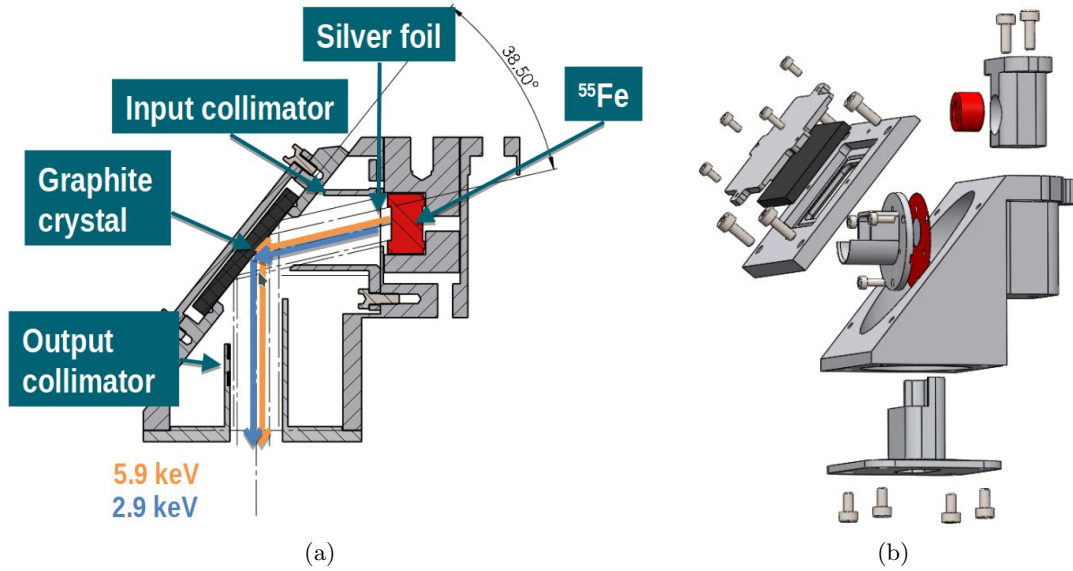

Figure 7. Cut-out (a) and exploded (b) view of Cal A.

	3.0 keV X-rays	5.9 keV X-rays
Production	Fluorescence from Ag foil	Direct emission from ^{55}Fe
Diffraction angle on graphite crystal	38.3 deg	38.7 deg
Polarization of diffracted photons	67%	69%
Image on the detector	Strip, 4x15 mm ²	Strip, 4x15 mm ²

Table 3. Characteristics of X-rays produced by Cal A.

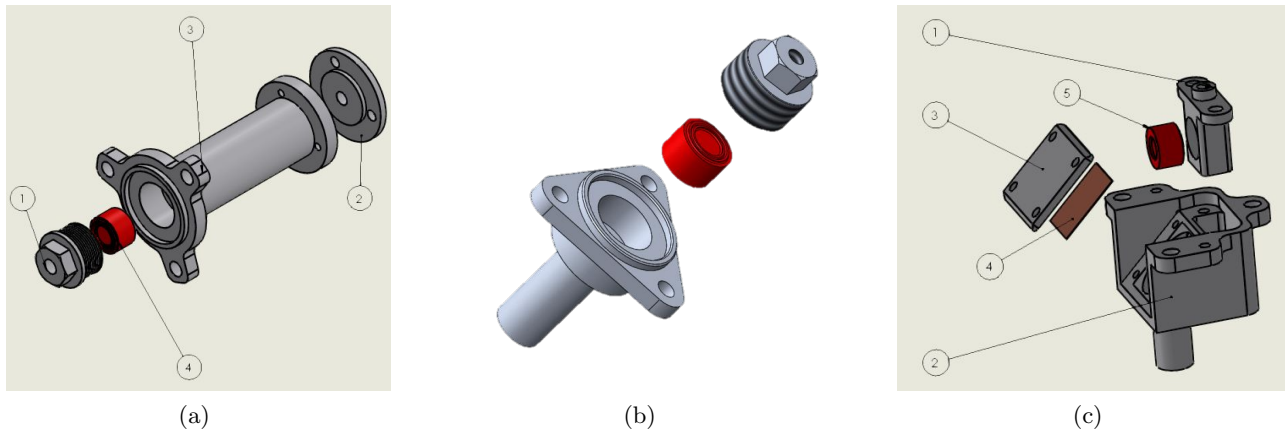

Figure 8. Exploded view of Cal B (a, left panel), Cal C (b, central panel) and Cal D (c, right panel).

possible through a dedicated opening in the DU lid. Radioactive sources, glued in their holders, will be extracted with dedicated tools and replaced with new ones in new holders. Test and dummy nuclides will be mounted in calibration sources for functional and environmental tests on-ground at INFN, IAPS, at MSFC and at Ball when the flight nuclides are not present.

Design of calibration sources in the FCW was put to test with prototypes and counting rates with the activity planned for in flight nuclides are extrapolated in Table 4.

Source	Activity on IXPE [mCi]	Counting rate [c/s]
Cal A	100	5.0 at 3.0 keV 80.0 at 5.9 keV
Cal B	20	60 at 5.9 keV
Cal C	0.5	100 at 5.9 keV
Cal D	10	20 at 1.7 keV

Table 4. FCW calibration sources counting rate expected at beginning of IXPE lifetime.

4. CONCLUSIONS

IXPE observatory will open a new window in X-ray astronomy and therefore its calibration will have to rely mainly on the characterization with laboratory sources. Calibration of the IXPE payload will be modular: mirror and focal plane instrument will be first calibrated separately and then jointly. On-ground Instrument calibration will be performed at INAF-IAPS in Italy and it will be dedicated to an extensive characterization of the GPD. Instrument calibration equipment will include polarized and unpolarized sources, whose custom design has been refined for 10 years during the development of the GPD. In-flight calibration will be possible thanks to four calibration sources which will be placed in front of the GPD when required by rotating a Filter and Calibration Wheel. Monitoring of the modulation factor at 3.0 and 5.9 keV will be possible with a single source of polarized X-rays. Absence of systematic effect will be verified at 5.9 keV, whereas gain monitoring and mapping will be possible at two energies, 1.7 and 5.9 keV.

ACKNOWLEDGMENTS

Italian contribution to IXPE mission is supported by the Italian Space Agency through agreement ASI-INAF n.2017-12-H.0 and ASI-INFN agreement n.2017-13-H.0.

REFERENCES

- [1] O'Dell, S. o. b. o. t. I. C., "The Imaging X-ray Polarimetry Explorer (IXPE): Overview," in [*Proc. of SPIE*], **10699** (2018).
- [2] Costa, E., Soffitta, P., Bellazzini, R., Brez, A., Lumb, N., and Spandre, G., "An efficient photoelectric X-ray polarimeter for the study of black holes and neutron stars," *Nature* **411**, 662 (2001).
- [3] Bellazzini, R., Spandre, G., Minuti, M., Baldini, L., Brez, A., Cavalca, F., Latronico, L., Omodei, N., Massai, M. M., Sgro', C., Costa, E., Soffitta, P., Krummenacher, F., and de Oliveira, R., "Direct reading of charge multipliers with a self-triggering CMOS analog chip with 105 k pixels at 50 μm pitch," *Nuclear Instruments and Methods in Physics Research A* **566**, 552 (2006).
- [4] Bellazzini, R., Spandre, G., Minuti, M., Baldini, L., Brez, A., Latronico, L., Omodei, N., Razzano, M., Massai, M. M., Pesce-Rollins, M., Sgró, C., Costa, E., Soffitta, P., Sipila, H., and Lempinen, E., "A sealed Gas Pixel Detector for X-ray astronomy," *Nuclear Instruments and Methods in Physics Research A* **579**, 853 (2007).
- [5] Soffitta, P., Barcons, X., Bellazzini, R., Braga, J., Costa, E., Fraser, G. W., Gburek, S., Huovelin, J., Matt, G., Pearce, M., Poutanen, J., Reglero, V., Santangelo, A., Sunyaev, R. A., Tagliaferri, G., Weisskopf, M., Aloisio, R., Amato, E., Attiná, P., Axelsson, M., Baldini, L., Basso, S., Bianchi, S., Blasi, P., Bregeon, J., Brez, A., Bucciattini, N., Burderi, L., Burwitz, V., Casella, P., Churazov, E., Civitani, M., Covino, S., Curado da Silva, R. M., Cusumano, G., Dadina, M., D'Amico, F., De Rosa, A., Di Cosimo, S., Di Persio,

- G., Di Salvo, T., Dovciak, M., Elsner, R., Eyles, C. J., Fabian, A. C., Fabiani, S., Feng, H., Giarrusso, S., Goosmann, R. W., Grandi, P., Grosso, N., Israel, G., Jackson, M., Kaaret, P., Karas, V., Kuss, M., Lai, D., Rosa, G. L., Larsson, J., Larsson, S., Latronico, L., Maggio, A., Maia, J., Marin, F., Massai, M. M., Mineo, T., Minuti, M., Moretti, E., Muleri, F., O'Dell, S. L., Pareschi, G., Peres, G., Pesce, M., Petrucci, P.-O., Pinchera, M., Porquet, D., Ramsey, B., Rea, N., Reale, F., Rodrigo, J. M., Róžańska, A., Rubini, A., Rudawy, P., Ryde, F., Salvati, M., de Santiago, V. A., Sazonov, S., Sgró, C., Silver, E., Spandre, G., Spiga, D., Stella, L., Tamagawa, T., Tamborra, F., Tavecchio, F., Teixeira Dias, T., van Adelsberg, M., Wu, K., and Zane, S., “XIPE: the X-ray imaging polarimetry explorer,” *Experimental Astronomy* **36**, 523 (2013).
- [6] Tamagawa, T., Hayato, A., Asami, F., Abe, K., Iwamoto, S., Nakamura, S., Harayama, A., Iwahashi, T., Konami, S., Hamagaki, H., Yamaguchi, Y. L., Tawara, H., and Makishima, K., “Development of thick-foil and fine-pitch GEMs with a laser etching technique,” *Nuclear Instruments and Methods in Physics Research A* **608**, 390 (2009).
- [7] Muleri, F., Soffitta, P., Bellazzini, R., Brez, A., Costa, E., Frutti, M., Mastropietro, M., Morelli, E., Pinchera, M., Rubini, A., and Spandre, G., “A versatile facility for the calibration of X-ray polarimeters with polarized and unpolarized controlled beams,” in [*Proc. of SPIE*], **7011**, 701127 (2008).
- [8] Muleri, F., Soffitta, P., Baldini, L., Bellazzini, R., Brez, A., Costa, E., Di Lalla, N., Del Monte, E., Evangelista, Y., Latronico, L., Manfreda, A., Minuti, M., Pesce-Rollins, M., Pinchera, M., Rubini, A., Sgrò, C., Spada, F., and Spandre, G., “Performance of the Gas Pixel Detector: an x-ray imaging polarimeter for upcoming missions of astrophysics,” in [*Space Telescopes and Instrumentation 2016: Ultraviolet to Gamma Ray*], Proc. SPIE **9905**, 99054G (2016).