

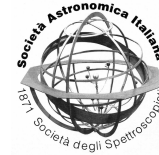

Publication Year	2018
Acceptance in OA @INAF	2021-02-12T10:37:24Z
Title	SETI in Sardinia: status of scientific and technological developments
Authors	MELIS, Andrea; CONCU, Raimondo; PERRODIN, DELPHINE; POSSENTI, ANDREA; Antonietti, N.; et al.
Handle	http://hdl.handle.net/20.500.12386/30349
Journal	MEMORIE DELLA SOCIETA ASTRONOMICA ITALIANA
Number	89



SETI in Sardinia: status of scientific and technological developments

A. Melis¹, R. Concu¹, D. Perrodin¹, A., Possenti¹, N. Antonietti, G. Aresu¹, M. Burgay¹, S. Casu¹, E. Egron¹, F. Loi¹, S. Loru¹, M.I. Lunesu⁴, C. Maccone², S. Milia¹, C. Migoni¹, S. Montebugnoli³, M. Murgia¹, A. Navarrini¹, P. Pari³, A. Pellizzoni¹, M., Pilia¹, T. Pisanu¹, A. Trois¹, V. Vacca¹, and G. Valente⁵

¹ INAF Osservatorio Astronomico di Cagliari, Via della Scienza 5, Selargius (CA), Italy
e-mail: andrea.melis@inaf.it

² INAF IASF Milano, Via Alfonso Corti 12, Milano (MI), Italy

³ INAF IRA Bologna, Via Gobetti 101, Bologna (BO), Italy

⁴ DIEE Università di Cagliari, Via Marengo 2, Cagliari (CA), Italy

⁵ Agenzia Spaziale Italiana, Via del Politecnico sn, 00133 Roma (RM), Italy

Abstract. Since 2013, several staff members of the Cagliari Astronomical Observatory have been involved with SETI activities, both from a technological and a scientific perspective. One major asset related to this research area is the presence, in the territory, of one of the most modern single-dish antennas: the Sardinia Radio Telescope (SRT). In this paper, we outline all aspects of our initiatives in the framework of the Search for ExtraTerrestrial Intelligence. We describe the development of SRT instrumentation for the purpose of receiving data that could potentially contain signs of life, as well as the directions that we are investigating for studying and analyzing these data, including in an international context.

Key words. Sardinia Radio Telescope, SERENDIP VI, KLT

1. Introduction

Starting in 2013, a number of the technological and scientific staff of the Cagliari Astronomical Observatory¹ (OAC) showed interest in the Search for ExtraTerrestrial Intelligence (SETI). In September 2013, one of the most sensitive single-dish radio telescopes in the world was inaugurated: the Sardinia Radio Telescope². The general-purpose nature of the telescope gave us the opportunity to

consider SETI as a possible scientific activity. Additionally, the growing number of exoplanets discovered in recent years had begun to substantiate this kind of research.

Historically, due to a very low chance of detecting intelligent extraterrestrial signals, the only allowed way for conducting SETI activities was in the so-called piggy-back mode. In this mode, a copy of the signal being acquired is re-processed by applying ad-hoc algorithms, which are expressly developed in order to search for any type of artificiality that could be attributed to an extraterrestrial civilization.

¹ <http://www.oa-cagliari.inaf.it/>

² <http://www.srt.inaf.it/>

In this regard, the pioneer in Italy was the SERENDIP (Search for Extraterrestrial Radio Emissions from Nearby Developed Intelligent Populations) IV spectrometer installed at the Medicina radio telescope³ in 1998, which operated for more than ten years. Currently, an upgraded version of the spectrometer is operational at the Arecibo and Green Bank Telescopes; one of the activities under development here is the porting of that system, called SERENDIP VI (Kyle 2016), to SRT. This will be described in Section 2.

As mentioned above however, the number of potentially habitable planets is constantly increasing, therefore simply searching in piggy-back mode is no longer the most desirable solution. Instead, the pilot project named “Breakthrough Listen Initiatives” (Croft 2018) (BL) has been brought forward at UC Berkeley. In particular, in the context of this program, 20% of the observing time available at the Green Bank and Parkes radio telescopes is currently dedicated to the most massive search for ET ever done. The scientific OAC team is in the early stages of a collaboration with UC Berkeley in order to analyze these data, both by applying conventional FFT-based software tools and by using new ones: in particular, the Kahrnunen-Loève Transform (KLT) and Wavelets. The possibility that SRT could be part of the BL project is being discussed both in terms of telescope time and operating modes.

The paper is organized as follows: Section 2 describes the SRT and the instrumentation for SETI that is under development (SERENDIP VI). In Section 3, we discuss how we plan to exploit alternative algorithms (KLT and Wavelets), while in Section 4, we report our conclusions.

2. The Sardinia Radio Telescope as a SETI facility

The Sardinia Radio Telescope is a new, general-purpose, fully-steerable, 64-m diameter radio telescope designed to work across the 0.3-116 GHz frequency range with high effi-

ciency. After the technical (Bolli et al. 2015) and scientific (Prandoni et al. 2017) commissioning of the telescope, an early science program was completed in August 2016; a few papers (Egron et al. 2017) (Govoni et al. 2017) (Loi et al. 2017) have already been published; other papers are in preparation. In March 2017, due to the partial corrosion of the electromechanical actuators that control the active surface, the main dish needed repair; the work was concluded in August 2017. Since then, technical&scientific re-commissioning activities have enabled us to verify the overall functionality of the refurbished telescope, as well as to complete the development of instruments such as backends, receivers, metrological systems and so on. The next call for proposals of the telescope is currently expected for the end of 2018.

As mentioned earlier, the telescope can operate within a wide frequency range. Three receivers are currently available: a dual-feed L-P band (305-410 MHz; 1300-1800 MHz) receiver (Valente et al. 2010), a mono-feed M-band (5.7-7.7 GHz) receiver (Orfei et al. 2006), as well as a seven-feed K-band (18-26.5 GHz) receiver (Orfei et al. 2010). A few other receivers are under development: a seven-feed S-band (3-4.5 GHz) receiver (Valente et al. 2014), a mono-feed C-band (4.2 - 5.6 GHz) receiver, a 19-feed Q-band (33-50 GHz) receiver, and a 9-feed W-band (86-115 GHz) receiver. For all receivers, a common digital platform may be configured for acquiring and processing radio astronomical signals collected by the telescope. In particular, FPGA-based digital boards allow the proper signal processing and versatility for each scientific requirements, which can be summarized in the following modes: continuum, spectroscopy, polarimetry, pulsars and fast transient emissions. Several platforms were developed in the past and are currently operational (Melis et al. 2014). The most powerful and recent one is the SARDINIA Roach2-based Digital Architecture for Radio Astronomy (SARDARA) backend (Melis et al. 2018); this general-purpose machine was recently commissioned and was already available in a preliminary version during the early science program of the SRT in 2016. Fig. 1

³ <http://www.med.ira.inaf.it>

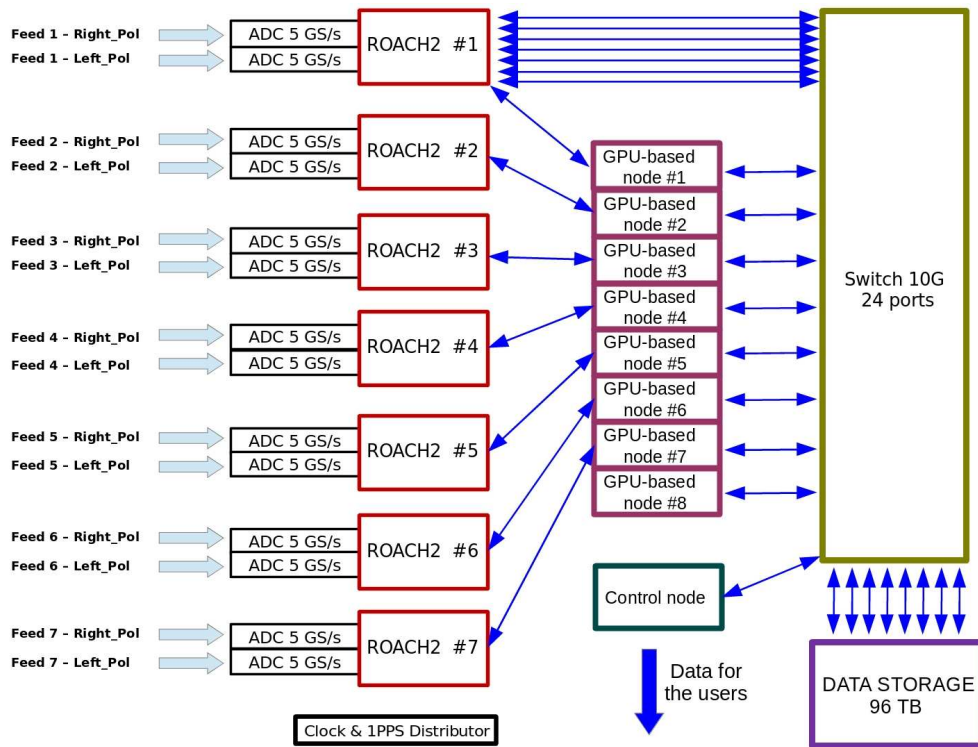

Fig. 1. SARDARA block diagram

shows a block diagram of SARDARA. The next section outlines how we will exploit SARDARA as a digital backend for SETI.

2.1. Porting of the SERENDIP VI onto SARDARA

SERENDIP is an acronym for Search for Extraterrestrial Radio Emissions from Nearby Developed Intelligent Populations. This project, led by UC Berkeley, has the goal of searching for potential signatures coming from extraterrestrial intelligent civilizations. In particular, SERENDIP VI can analyze a wide swath of the electromagnetic spectrum at the Arecibo radio telescope in Puerto Rico, and at the Green Bank Telescope (GBT) in West Virginia (USA). The system consists in a wide-band spectrometer with a large number of spectral channels; the goal is to obtain an extremely narrow-band resolution,

of the order of less than a Hz. This is required for detecting a possible quasi-monochromatic alien message, which is the most probable kind of signal that an extraterrestrial civilization might use to communicate with another one.

In particular, SERENDIP VI can digitize the incoming signals with a bandwidth of up to 2.4 GHz, and split them up into 4096 channels; it can further split each of these 4096 channels into fine channels on GPUs. Each GPU can process a 300-MHz bandwidth; a search for signals above a particular threshold is performed. One of the major advantages of this system is that we can do the following activities simultaneously: SETI, searches for pulsars and searches for Fast Radio Bursts (FRBs). In particular, since FRBs are still unknown phenomena (we do not know their origin), an untargeted search for FRBs can go hand in hand with SETI activities in a natural way. SARDARA uses the same hardware as

that used at GBT for the SERENDIP VI setup. In particular, ROACH2 boards are used in the same configuration in both systems, therefore a porting of the GBT setup to SRT is easily feasible. As shown in Fig. 1, all eight 10-Gbps links of the first ROACH2 are connected to a switch. This means that the entire digital bandwidth can be split into eight sub-bands of up to 300 MHz each, and then sent to the eight GPU-based workstations. All of the workstations can be used for dedicated SETI observations; alternatively, for the piggy-back observing mode, we may only use a subset of them. In any case, since an eighth ROACH2 board is reserved for the L-band receiver, we can always perform piggy-back SETI observations, regardless of the ongoing observations.

3. Mathematical alternative algorithms for SETI

In this section, we briefly outline two mathematical algorithms that we are currently investigating for SETI applications: the Kahrunen-Loève Transform (KLT) and Wavelets. The Fast Fourier Transform (FFT) uses sines and cosines to represent a generic signal. This approach is well known and is used in the vast majority of cases, including in the search for life in our Galaxy. Although the FFT may be considered to be the ideal solution for detecting (quasi) monochromatic signals associated with intentional messages sent by an advanced extraterrestrial civilization, the same cannot be said for unintentional (probably wide-band) signals coming from these civilizations. In this case, the FFT approach would be far too limiting; we prefer to adopt solutions where each orthonormal function is calculated in the basis of the signal being acquired, as is the case for the KLT. Moreover, a Wavelet-based solution has been tested and given us a preliminary result that we describe in Section 3.2.

3.1. Kahrunen-Loève Transform (KLT)

The KLT is a mathematical procedure that is capable of extracting, out of the background cosmic noise, signals with a SNR that is much lower than one, in which case the FFT fails. An

in-depth description of the KLT goes beyond the scope of this paper; we suggest reading our previous paper (Melis et al. 2016). What we intend to present here are the activities involving the KLT both for SETI and for the search for FRBs. Since 2016, we have started a close collaboration with UC Berkeley, with the goal of implementing the KLT at SRT and at the BL telescopes. About once a month, we are holding a teleconference between Italian members and the Berkeley groups who are interested in this matter. We note that in addition to unavoidable difficulties due to different time zones, a few research members hold another job for a living and work on the KLT only for passion; this is commendable but introduces further critical issues. Despite all this, this collaboration is very fruitful and substantial progress has been made. Currently, two algorithms are under development: one dedicated to SETI and one to the search for FRBs. For the latter, raw data from the Breakthrough Listen program of an FRB observed with the Parkes telescope have been made available; we are using them to validate our algorithms.

In July 2018, a busy week will be held at UC Berkeley. The following Italian representatives are planning to attend this busy week: Nicolo' Antonietti, Marta Burgay, Raimondo Concu, Claudio Maccone, Andrea Melis, Alessandro Navarrini, Pierpaolo Pari, Delphine Perrodin, and Maura Pilia. This meeting will represent the highest peak of this promising collaboration; we are positive that our efforts will produce benefits in the search for intelligent life for SRT, GBT and Parkes in the near future, and also strengthen the collaboration between Italy and USA in this field.

3.2. Wavelets

Wavelets are mathematical functions that split up data into different frequency components, and then study each component with a resolution that is matched to its scale. They are used in several applications in the field of digital signal processing.

For astrophysics in particular, signals display a periodic behavior that is characterized by a well-defined localization in the frequency

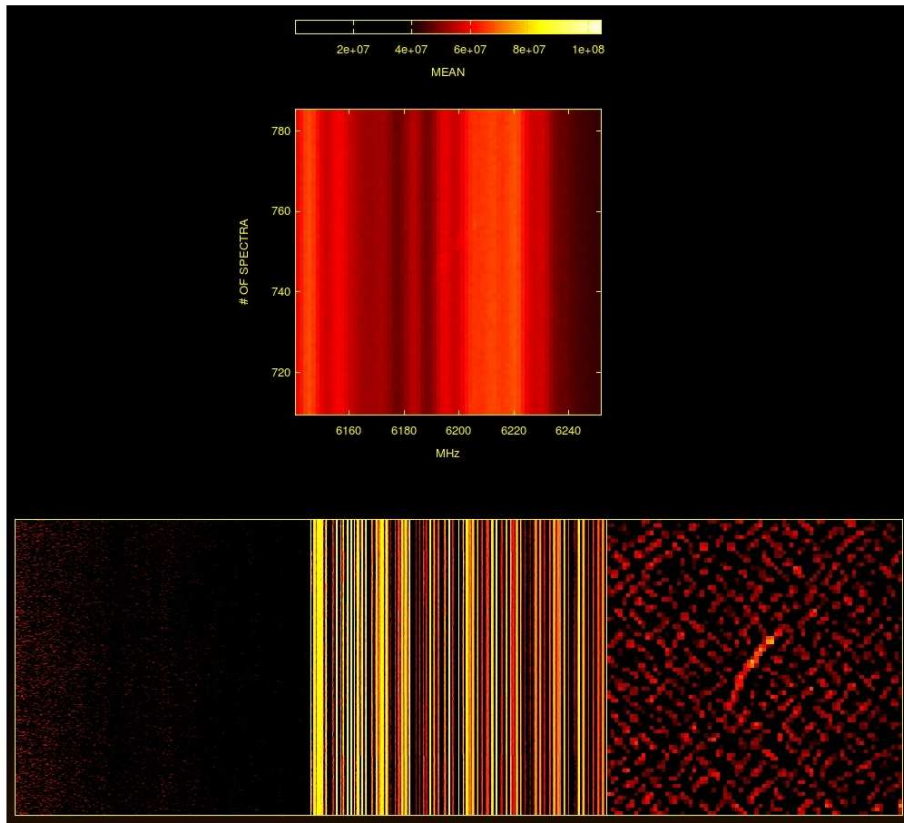

Fig. 2. Wavelet decomposition (bottom panel) of a cold region of the sky (top panel). Showing horizontal, vertical and diagonal detail coefficients, an inclined signal is clearly detected in diagonal coefficients

domain. In fact, the traditional FFT-based technique is very effective in revealing signals at a particular frequency. However, many real-world sources show time variation in frequency and amplitude, which can be difficult to catch and analyze with the standard FFT approach. In contrast, wavelets are localized both in frequency and in time and are thus able to handle non-stationary signals. In particular, wavelets are very useful for handling features such as sharp transients or frequency changes. We have successfully employed the wavelet analysis to separate the true sky signal from the scanning noise for the imaging of spectral polarimetric SRT data acquired with the SARDARA backend. Figure 2 shows our preliminary results. In light of this, we are now considering developing Wavelet-based techniques as an alternative

tool for processing data collected in the context of SETI activities.

4. Conclusions

In this paper, we have described the numerous SETI activities that are currently ongoing in Sardinia, at OAC and SRT in particular. With regard to the SRT, we are finalizing all of the necessary hardware and software needed to start SETI observing as soon as possible, starting with the first call for proposals (end of 2018). At the same time, we are investigating alternative mathematical solutions like the KLT and Wavelets, in close collaboration with UC Berkeley and in particular with members involved in the Breakthrough Listen program.

References

- Archer, K., et al. 2016, Commissioning and testing of SERENDIP VI instrumentation USNC-URSI national radio science meeting, in 2016 United States National Committee of URSI National Radio Science Meeting (USNC-URSI NRSM)
- Bolli, P., et al. 2015, *J. Astron. Instrum.*, 4, 150008
- Croft, S., et al. 2018, The Breakthrough Listen Search for Intelligent Life, in 231st AAS Meeting, 231.01
- Egion, E., et al. 2017, *MNRAS*, 470, 1329
- Govoni, F., Murgia, M., Vacca, V., et al. 2017, *A&A*, 603, A122
- Loi, F., Murgia, M., Govoni, F., et al. 2017, *MNRAS*, 472, 3605
- Melis, A., et al. 2014, *Proc. SPIE*, 9153, 91532M
- Melis, A., et al. 2016, *Proc. SPIE*, 9914, 99143D
- Melis, A., et al. 2018, *J. Astron. Instrum.*, 7, 1850004
- Orfei, A., et al. 2010, *IEEE Antenn. Propag. M.*, 52, 62
- Orfei, A., et al. 2011, Caratterizzazione del ricevitore nella banda 5.7 - 7.7 GHz, SRT memo series GAI04-FR-5.0
- Prandoni, I., et al. 2017, *A&A*, 608, A40
- Valente, G., et al. 2010, *Proc. SPIE*, 7741, 774126
- Valente, G., et al. 2014, *Proc. SPIE*, 9153, 91530Q