



<b>Publication Year</b>	2016
<b>Acceptance in OA @INAF</b>	2020-05-29T15:58:35Z
<b>Title</b>	A real-time FFT-KLT implementation for SETI research at the Sardinia Radio Telescope
<b>Authors</b>	MELIS, Andrea; CONCU, Raimondo; PARI, PIERPAOLO; Maccone, Claudio; POSSENTI, ANDREA; et al.
<b>Handle</b>	<a href="http://hdl.handle.net/20.500.12386/25298">http://hdl.handle.net/20.500.12386/25298</a>

## A real-time FFT-KLT implementation for SETI research at the Sardinia Radio Telescope

Andrea Melis<sup>a\*</sup>, Raimondo Concu<sup>a</sup>, Pierpaolo Pari<sup>c</sup>, Claudio Maccone<sup>b</sup>, Andrea Possenti<sup>a</sup>, Giuseppe Valente<sup>a</sup>, Delphine Perrodin<sup>a</sup>, Carlo Migoni<sup>a</sup>, Alessio Trois<sup>a</sup>, Silvia Casu<sup>a</sup>, Maria Ilaria Lunese<sup>d</sup>, Alessandro Navarrini<sup>a</sup>, Tonino Pisanu<sup>a</sup>, Francesco Schillirò<sup>e</sup> and Valentina Vacca<sup>a</sup>

<sup>a</sup> INAF Osservatorio Astronomico di Cagliari, Via della Scienza 5, Selargius (CA), Italy

<sup>b</sup> INAF IASF Milano, Via Alfonso Corti 12, Milano, Italy

<sup>c</sup> INAF IRA Bologna, Via Gobetti 101, Bologna, Italy

<sup>d</sup> DIEE University of Cagliari, Via Marengo 2, Cagliari, Italy

<sup>e</sup> INAF Osservatorio Astrofisico di Catania, Via S. Sofia 78, Catania, Italy

\* Corresponding Author

### Abstract

The Search for ExtraTerrestrial Intelligence (SETI) is a project whose goal is to find possible life signatures emitted (intentionally or unintentionally) by possible civilizations from other habitable planets. Historically, the narrow-band FFT approach has been used, since a quasi-monochromatic signal is the most probable signal one would use to send a message to another world, that is in the case of intentionally-transmitted signals. Nevertheless, we could receive an unintentionally-transmitted signal as well. In that case, it would most certainly not be a quasi-monochromatic signal, but would probably be similar (with a wider bandwidth, of the order of MHz) to the signals that we use for conventional communications on Earth. The Kahrunen-Loève Transform (KLT) is a powerful algorithm for such a kind of research. However, a real-time implementation of the KLT has thus far not worked due to a lack of technological resources. We describe a hardware-software infrastructure at the Sardinia Radio Telescope (SRT) that, in real-time, makes it possible to perform the KLT in parallel to the FFT.

**Keywords:** KLT, FFT, SETI, SRT, FPGA, GPU

### Acronyms/Abbreviations

- Fast Fourier Transform (FFT)
- Fast Radio Burst (FRB)
- Field Programmable Gate Array (FPGA)
- Graphical Processing Unit (GPU)
- Green Bank Telescope (GBT)
- Kahrunen-Loève Transform (KLT)
- Intermediate Frequency (IF)
- On-The-Fly (OTF)
- Reconfigurable Open Architecture Computing Hardware (ROACH)
- Sardinia Radio Telescope (SRT)
- Search for ExtraTerrestrial Intelligence (SETI)
- Search for Extraterrestrial Radio Emissions from Nearby Developed Intelligent Populations (SERENDIP)
- Signal-to-Noise-Ratio (SNR)

### 1. Introduction

The Sardinia Radio Telescope (SRT) [1] is the largest radio telescope in Italy. It was inaugurated in

September 2013 and, after two years of astronomical validation [2], the early science phase started in February 2016, immediately providing interesting scientific results.

SRT has a diameter of 64 meters and an active surface, thus it can be used for several applications, among which SETI programs.

Historically, the search for the evidence of intelligence life in the universe has been done by employing the traditional FFT-based approach. The basic idea is that, if it would want to communicate with Earth, a hypothetical extraterrestrial civilization would send the same kind of signal that we would send out if we wanted to be heard; indeed, there is no doubt that a monochromatic signal - easily suitable with the Fourier Transform algorithm - would be the most logical choice.

The most important project - led by the University of Berkeley, California - is the SERENDIP (Search for Extraterrestrial Radio Emissions from Nearby Developed Intelligent Populations) project [3]. It currently involves the Arecibo radio telescope and the Green Bank Telescope. The project is mainly conducted in piggy-back mode, namely the signal that is being acquired during a scientific observation is re-analysed by powerful spectrometers, which are able to break up

the signal into small frequency channels, of the order of a fraction of Hz.

However, this is not necessarily the unique useful way to search for extraterrestrial intelligence. In fact, we could receive a non-intentional signal, for instance that coming from a satellite that orbits a habitable planet. In this case, that type of signal would have a large spectrum as compared to a monochromatic one.

Hence, in this case, the FFT would no longer be the ideal solution; the best way for such a kind of scenario is the KLT (Kahrunen-Loève Transform); the signal's extraction can be achieved with the KLT more accurately as compared to the FFT, especially if the signals buried in the noise are very weak.

A first platform to perform the KLT has been implemented at SRT and is described here [4].

In this paper, we present an infrastructure that allows us to simultaneously perform the FFT and the KLT at SRT, by exploiting both the SERENDIP VI and the KLT frameworks.

## 2. Introduction to the KLT

The KLT is a mathematical procedure capable of extracting, out of the background cosmic noise, signals with a SNR that is much lower than one. In other words, the KLT is much superior to the Fast Fourier Transform (FFT), which starts failing the weak signal extraction when  $SNR < 1$ . How is that possible? First of all, while the FFT only uses sines and cosines as the set of orthonormal functions by which the signal expansion into an infinite series is achieved, the KLT may use a host of different orthonormal functions (basis functions) discovered by mathematicians in the last two centuries: Bessel functions, prolate spheroidal functions, Haar functions typical of Wavelets, and so forth. Actually, the KLT discovers which set of basis functions is most suitable to describe the input stochastic process by establishing that these basis functions are the *eigenfunctions* of the autocorrelation of the input process. In saying so, we have implicitly stated that the KLT is a statistical tool to recover weak signals out of the noise, rather than a deterministic tool as the FFT is.

The “difficulty” with the KLT is that, for  $N$  samples of the input, it scales like  $N^2$  or worse, while the FFT scales like  $N \cdot \ln(N)$ . In other words, the FFT is much faster than the KLT, which is why the FFT was preferred to the KLT in the 70 years elapsed since its discovery in 1946 by the Finnish actuary, Kari Karhunen (1915-1992) and the French-American mathematician, Michel Loève (1907-1979). If time is regarded as a continuous variable, as in classical physics, then you must first know an analytical expression for the input noise (such as the autocorrelation of the Brownian motion) and

then, analytically, solve the integral equation with such an autocorrelation as its kernel: therefore, you get both the eigenvalues and eigenfunctions, and the KLT is found. However, if the time is discrete, the above integral equation becomes a system of simultaneous linear algebraic equations, whose solution may require a long time. In SETI, the KLT was first recognized as a good innovative algorithm for detecting an Alien signal by François Biraud at Nançay in 1983 and, independently, by Bob Dixon in the USA (mid 1980s) and Claudio Maccone in Italy in 1987.

The mathematical treatment of the KLT is amply presented in [4], where its CPU-GPU implementation is explained as well. Substantially, the objective is to get the axes that describe the acquired signals (for instance by a large radio telescope) in the best possible way; in order to do that, we calculate the eigenvectors/eigenvalues of the autocorrelation matrix of these signals. Thus, once we obtain both the eigenvalues and the eigenvectors, SETI experts can then pursue a specific and deep analysis of these values.

## 3. SERENDIP VI project

As mentioned earlier, SERENDIP is an acronym for “Search for Extraterrestrial Radio Emissions from Nearby Developed Intelligent Populations”. It is a project led by UC Berkeley for searching the potential signatures coming from an extraterrestrial life form. In particular, it scans a wide range of frequencies by exploiting data from the Arecibo radio telescope in Puerto Rico, and the Green Bank Telescope (GBT) in West Virginia.

The idea behind the SERENDIP project is to make an automated system that is able to perform a real-time search for extremely narrow-band (of the order of Hz) signals. This is done by exploiting powerful spectrometers with a huge number of spectral channels. The first version [5] of the SERENDIP dates back to 1979; it was an instrument with only 100 channels, and was surpassed a few years later by another instrument [6] able to perform up to 65536 channels and, in later years, by enhanced versions ([7], [8]) of the machine. Today, the current version is SERENDIP VI [9].

It is implemented by using the modern FPGA-based ROACH2 [10] board both at Arecibo and GBT, even if the two versions are slightly different; we focus on the GBT version because it is the one that we will employ at SRT.

In particular, the GBT version of SERENDIP VI is able to digitize the incoming signals with a bandwidth of up to 2.4 GHz; thus, we break them up into 4096 channels using a polyphase filter bank engine.

The 4096 complex numbers are then sent to computers equipped with powerful GPUs.

The GPUs break these 4096 coarse channels up into fine channels (about 1 Hz each), do baseline smoothing, and search for signals above a particular threshold.

Each GPU can process a 300 MHz bandwidth when programmed with the SETI application.

The SERENDIP VI machine at Arecibo runs continuously (whenever anyone is observing) and does two things (not just SETI): it does SETI and simultaneously searches for Fast Radio Burst (FRBs) (it has two sets of GPUs - some for SETI, and some for FRBs). At SRT, we are going to do the same thing.

#### 4. An infrastructure for the simultaneous application of the FFT and the KLT at the Sardinia Radio Telescope

In this chapter, we describe an infrastructure that makes it possible to simultaneously perform the FFT and the KLT of the acquired signals at SRT.

Essentially, the system employs the SERENDIP VI framework software in the conventional narrow-band FFT-based approach; at the same time, a portion of the spectrum is sent to the KLT engine described in [4].

From a hardware point of view, we exploit the recently commissioned back-end named SARDARA (Sardinia Roach2-based Digital Architecture for Radio Astronomy) [11], whose block diagram is shown in fig. 1:

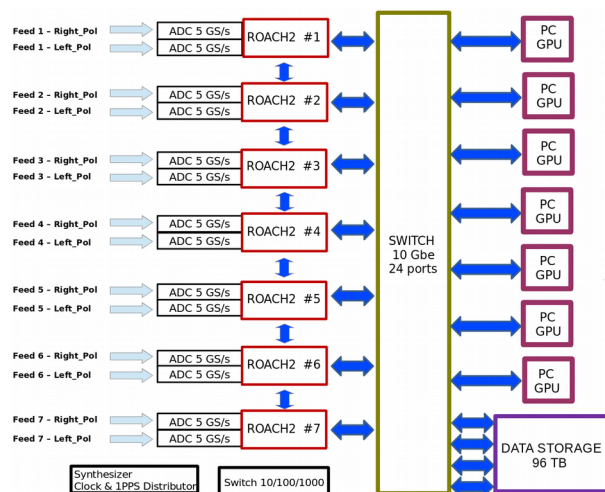

Fig.1. Block diagram of the SARDARA digital back-end

The platform is thought of as a digital back-end capable of managing up to 14 intermediate frequency signals (IF), i.e. those provided by a seven-feed K-band receiver available at SRT. A single ROACH2 board is

able to digitize up to two IFs with an instantaneous bandwidth of 2.5 GHz, thus a full-Stokes spectrometer for each feed can cover all possible scientific requirements of the telescope.

The blue arrows indicate the 10 Gbe optical fibre connections. As shown in the block diagram, each element can reach any other element, and in particular each ROACH2 is connected to any other ROACH2; therefore, the processing can easily be distributed so as to increase the computing capability of SARDARA.

Specifically, the current mode for SETI is the piggy-back mode, thus the available computing resources are dependent on the kind of observation being conducted.

The ideal scenario is when a mono-feed receiver is being used; in fact, in this case, only a single chain ROACH2 is needed. On the contrary, the worst case is when a seven-feed observation must be done; however, an additional ROACH2-GPU chain can be used, so that SETI can always be performed, even with reduced computing capability.

As previously mentioned, SERENDIP VI can deal with an instantaneous bandwidth of up to 2.4 GHz, and each GPU can manage up to 300 MHz.

Each ROACH2 has eight 10 Gbe outputs provided by two mezzanine cards. One of them is directly connected to the switch, while the others are connected to the other boards as mentioned before. In that way, we define the ROACH2 that digitizes the signal as “master” and the ROACH2s that receive a 300 MHz-wide sub-band as “slaves”. Each of these data streams can be sent to a particular computer simply by configuring the FPGA of each ROACH2 slave as a “hub”. In order to do that, we implement a personality that merely forwards the data through the output of the ROACH2 that is connected to the 10 Gbe switch.

By doing so, the available bandwidth for SETI is always, in a dynamic way, the largest allowed.

With regard to the KLT, the approach is very different. The complexity of the transform - as well as the number of operations needed - drastically reduces the manageable instantaneous bandwidth; it is therefore unthinkable to handle the aforementioned stream of data (300 MHz for each node). The current capability in terms of digital processing is, for the KLT, roughly 40 KS/s, as explained in [4].

A first reduction of the bandwidth is provided by the personality used for SERENDIP VI, which divides the input bandwidth into 4096 sub-bands: for the KLT only one of them can be considered, converted into real format and sent to the KLT engine.

The KLT calculates eigenvalues and eigenvectors for each window of incoming samples as if these subsequent windows were independent signals; in other words, the integration is not allowed as in the case of

the Fourier Transform, therefore every segment of the signal can be studied independently from the others. As a consequence, the distribution of the base-band data among different nodes is greatly simplified.

The strategy for SETI with the KLT is very closely linked to the kind of science being conducted at SRT. There are two major scenarios: pointing mode and on-the-fly (OTF) mapping mode.

In the first case, the telescope points to the scientific target for a certain time and, as a consequence, a sweep of the bandwidth is the best solution. Thus, we can process – one after the other - a variable number of the sub-bands provided by SERENDIP VI. The acquisition time for each sub-band varies depending on how much time the antenna remains on the source; it can vary from a few seconds (raster scan mapping) to hours (pulsars). On the contrary, an OTF observation is conducted continuously by moving the telescope so as to map a large sky area, for instance supernovae remnants. In this case, only one sub-band is analysed by the KLT for the entire duration of the observation.

Each node of SARDARA is equipped with a considerable RAM memory (256 GB) and disk space (16 TB), therefore there is enough flexibility in case the node had to be suddenly released. In particular, a variable buffer of data is stored and immediately transferred to the data storage and processed later.

At present, the contemporaneous implementation of the two transforms on the same node is rather unsuitable, hence the number of computers that deal with the FFT or the KLT is dynamically changed.

For instance, at SRT the P-band receiver [12] has an instantaneous bandwidth of 105 MHz, thus a GPU node is sufficient for the SERENDIP VI, and the others can be used for the KLT. If instead the L-band receiver [12] is being used, in order to cover the 500 MHz provided by the receiver, two nodes are needed for the FFT, and so on.

Finally, when the astronomers observe with the seven-feed K-band receiver [13], the eighth ROACH2 is used for SETI and the available eighth and ninth nodes perform the FFT and the KLT, respectively.

## 5. Conclusions and future works

In this paper, we described a platform with which we are able to conduct, in piggy-back mode, SETI observations at the Sardinia Radio Telescope, presumably from 2017.

The well-known narrow-band FFT approach – on which the SERENDIP VI project is based – is “accompanied” by the KLT one, which is more suitable for the detection of a wide-band intelligent signal.

The very high computational load required – in particular in the case of the KLT – is distributed among FPGAs, CPUs and GPUs; future developments are increasingly going to exploit the former, especially because of their exponential growth in terms of computing power.

Finally, if given the opportunity, SRT could be part of the “Breakthrough Listen SETI” [14]. In this case, a portion of the telescope time would be dedicated to SETI purposes; the possibility to point the antenna to a potentially habitable sky area can, undoubtedly, increase the percentage of success for revealing ETI.

## Acknowledgements

We are very grateful to the staff of the Berkeley SETI institute for their help for the porting of SERENDIP VI at SRT. In particular, a big thanks to David MacMahon, Andrew Siemion, Dan Werthimer and Jeff Cobb for their efforts and helpfulness.

Moreover, a special thanks to the Autonomous Region of Sardinia (RAS) [15] that has funded the project named “High resolution sampling of the Universe in the radio band: an unprecedented instrument to understand the fundamental laws of nature” - P. I. of the project Andrea Possenti - in the context of the research project CRP-49231 (year 2011). This financing allows the development of the SARDARA platform.

## References

- [1] P. Bolli et al. “*Sardinia Radio Telescope: General Description, Technical Commissioning and First Light*” *Journal of Astronomical Instrumentation*, Vol. 4, Nos. 3 & 4 (2015) 1550008 (20 pages)
- [2] I. Prandoni, A. Melis, C. Migoni, D. Perrodin et al. “*The SRT in the Context of European Networks: Astronomical Validation & Future Perspectives*”, *Proceeding of Science*, 12th European VLBI Network Symposium and Users Meeting, 7-10 October 2014 Cagliari, Italy
- [3] <https://seti.berkeley.edu/SERENDIP.html>
- [4] Andrea Melis, Raimondo Concu, Pierpaolo Pari, Claudio Maccone et al. “*A real-time KLT implementation for radio-SETI applications*”, *Proc. SPIE* 9914, Millimeter, Submillimeter, and Far-Infrared Detectors and Instrumentation for Astronomy VIII, 99143D (July 20, 2016); doi:10.1117/12.2232347

- [5] Stuart Bowyer, Dan Werthimer, Charles Donnelly, Michael Lampton, Walter Herrick, Jennifer Soller, David NG and Tucker Hiatt :”*The SERENDIP SETI project*”, Third Decennial US-USSR Conference on SETI, ASP Conference series, Vol. 47, 1993
- [6] Dan Werthimer, Jill Tarter and Stuart Bowyer: ” *The SERENDIP II design*”, Proceedings of the Symposium, Boston, MA, June 18-21, 1984 (A86-38126 17-88). Dordrecht, D. Reidel Publishing Co., 1985, p. 421-424
- [7] Werthimer D., Ng, D., Bowyer S., Donnelly, C. “*The Berkeley SETI Program: SERENDIP III and IV Instrumentation*”, Astronomical Society of the Pacific Conference Series, Volume 74. Progress in the Search for Extraterrestrial Life. 1993 Bioastronomy Symposium, held in Santa Cruz, California, August 16-20,1993.
- [8] CASPER's technical description: [https://casper.berkeley.edu/wiki/SETI\\_Spectrometer](https://casper.berkeley.edu/wiki/SETI_Spectrometer)
- [9] CASPER's technical description: [https://casper.berkeley.edu/wiki/SETI\\_FRB\\_Spectrometer\\_\(SERENDIP\\_VI\)](https://casper.berkeley.edu/wiki/SETI_FRB_Spectrometer_(SERENDIP_VI))
- [10] [https://casper.berkeley.edu/wiki/ROACH-2\\_Revision\\_2](https://casper.berkeley.edu/wiki/ROACH-2_Revision_2)
- [11] Andrea Melis :”*Wideband Digital Instrumentation for the Italian Radio Telescopes*”, PhD Thesis, University of Cagliari (Italy), 2016
- [12] Valente, G., Pisanu, T., et al. “*The dual-band L-P feed system for the Sardinia Radio Telescope prime focus*,” Proc. SPIE Millimeter, Submillimeter, and Far-Infrared Detectors and Instrumentation for Astronomy V 7741 (2010).
- [13] Orfei, A., et al. “*A Multi-feed Receiver in the 18-26.5 GHz Band for Radio astronomy*”, IEEE Ant. Prop. Magazine, 52(4), 62, 2010.
- [14] <https://seti.berkeley.edu/listen/>
- [15] <http://www.regione.sardegna.it/>