

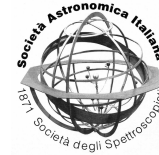

Publication Year	2015
Acceptance in OA @INAF	2020-03-27T10:10:34Z
Title	Industrial solutions trends for the control of HiRes spectrograph@E-ELT
Authors	DI MARCANTONIO, Paolo; BALDINI, Veronica; CALDERONE, GIORGIO; CIRAMI, ROBERTO; CORETTI, Igor; et al.
Handle	http://hdl.handle.net/20.500.12386/23639
Journal	MEMORIE DELLA SOCIETA ASTRONOMICA ITALIANA
Number	86



Industrial solutions trends for the control of HiRes spectrograph@E-ELT

P. Di Marcanonio, V. Baldini, G. Calderone, R. Cirami, I. Coretti, and S. Cristiani

Istituto Nazionale di Astrofisica – Osservatorio Astronomico di Trieste, Via Tiepolo 11,
I-34143 Trieste, Italy, e-mail: dimarcan@oats.inaf.it

Abstract. Starting a few years ago, ESO initiated a number of projects aiming to explore the possible adoption of industrial standards and commercial off-the-shelf components (COTS) for the control of future VLT and E-ELT instrumentations. In this context, ESPRESSO, the next generation high-stability spectrograph for the VLT and to a certain extent, a precursor of HiRes, has adopted since the preliminary design phase those solutions. Based on the ESPRESSO experience and taking into account the requirements inferred from the preliminary Hi-Res studies in terms of both high-level operations as well as low-level control, I will present in this paper the current proposal for the HiRes hardware architecture.

Key words. E-ELT instruments: control electronics – E-ELT instruments: control software – COTS – Industrial standards

1. Introduction

In the past, due to limited industrial solutions that could fit astronomical requirements in terms of devices control, there was no other choice as to develop, ad-hoc, custom solutions for most of the hardware/software control related aspects. This was the case for the ESO VLT Observatory and in the literature a lot of examples could be found that report the same happening for other Observatories (Ghedina et al. 2014).

Even though requirements were in this way fulfilled, this approach has inherently several drawbacks: custom solutions are expensive both to develop and implement as well as to maintain (especially on a long term). Engineers that contribute to the initial development not always remain in the same working place and in course of the time the “painful” process

of know-how transfer could become an issue. Moreover, for more hardware related aspects, it is well known that technology is advancing very fast, and the core components chosen in the early design days may soon become obsolete yielding problems for system maintainability.

For all these reasons and looking ahead towards the E-ELT era, ESO, with the contribution of INAF-OATs, started to investigate the possible adoption of widely accepted COTS industrial standards components with the aim of lowering the system procurement and maintenance costs as well as of mitigating obsolescence by improving components interoperability.

In this paper, after describing the outcome of these studies, I’ll present the results applied to the control of the forthcoming HiRes spectrograph for the E-ELT. As a real, working ex-

ample, I will also introduce the ESPRESSO case, the new high-resolution spectrograph for the VLT (Mégevand et al. 2014) which could be seen as a test bed for the future HiRes instrument.

2. The VLT case

The current VLT standard dedicated to the control of hardware sub-systems of all the instruments, including telescopes in Paranal, is heavily based on the concept of a *VME-based Local Control Unit* (shortly, LCU). The VME bus (which is, by the way, an industrial international standards) interconnects (specific) CPU board with others dedicated to perform particular tasks such as motion control, analog/digital signal I/Os etc. composing what is known as “the VME crate”. The actual limitation is that there is a strong software/hardware coupling in the way ESO has implemented this architecture which prevents to easily change the obsolete boards without significant changes in the associated software. Several limits in terms of deployment and distribution also came out when trying to adapt this architecture to the ESPRESSO case (and in perspective to the HiRes) which is inherently distributed due to its capability to use any of the 4 UTs.

The VME-based real-time control architecture concept has been used by ESO also to control the technical CCDs (shortly, TCCDs) needed for stabilization or for secondary guiding purposes at the instrument level. The ESO compliant TCCDs, although fulfilling the astronomical requirements, are however expensive in terms of costs, manufacturing, integration and maintenance especially if compared to available COTS devices one can find on the market which led to seek for other solutions already for the ESPRESSO case.

To overcome all these issues, ESO and INAF-OATs initiated several projects aiming at modernize the VLT hardware/software control system. The eventually identified technologies are currently adopted in ESPRESSO and will very likely constitute the core for the control of future E-ELT instruments.

3. Industrial trends

The key point when analyzing industrial trends for the future E-ELT is the level of “standardization”. Only components adhering to wide spread accepted standard (possibly, IEEE certified) could overcome or mitigate the obsolescence guaranteeing interoperability and interchangeability considering the long foreseen time span for the E-ELT instrumentation (at least 10 years from now for first operations, followed by 20-30 years of lifetime). Based on this, the proposed control of the future HiRes spectrograph, follows **standard** industrial trends (where applicable) in the following areas:

- fieldbus distribution;
- time synchronization;
- high performance camera communication;
- unified architecture;
- device control.

The proposed solutions are not only “paperwork”, but are currently being applied (for the first time at the VLT for a permanent instrument) to the ESPRESSO control case; additional information could be found in (Baldini et al. 2014) and references therein.

3.1. Fieldbus distribution

The current trend in control paradigm departs slightly from the VLT adopted one by superseding the centralized vision and by putting more emphasis on distributed architectures interconnecting intelligent nodes (like PLCs, see Fig. 1). The interconnections could be

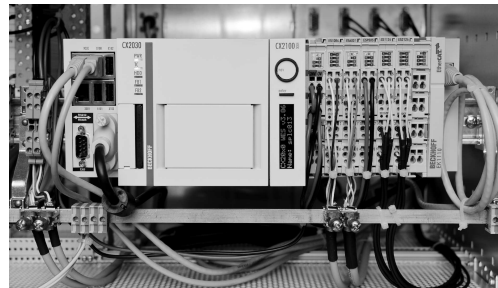

Fig. 1. Example of Beckhoff Automation PLC CPU and modules

achieved by dedicated networks on which proprietary (or open) protocols run, as well as by dedicated networks based on standard Ethernet infrastructure. For our applications, the latter seems the most appropriate choice since this will allow to fully reuse future infrastructure that will be certainly available at the E-ELT not imposing additional requirements. Example of real-time protocols that could run on such Ethernet-based fieldbus systems are EtherCAT (standardized in IEC 61158) invented (and used by COTS provided) by Beckhoff Automation or PROFINET used by Siemens.

3.2. Time synchronization

Even though at the time of writing this paper no definitive requirements are imposed by E-ELT to external consortia involved in the feasibility studies for the instrumentation, the time synchronization protocol is an exception in this context. Several tests have been made in the past years and the final choice is to rely, for time synchronization, on the Precision Time Protocol (PTP, standardized as IEEE 1588), which allows to reach accuracy in the sub-microsecond range. Due to very positive results, also VLT (and consequently ESPRESSO) is going to adopt the same protocol (superseding the current custom solution available at Paranal). Both Siemens and Beckhoff Automation offer COTS components based on this protocol (as well as other vendors) which guarantees interoperability and long lifetime also looking ahead towards E-ELT instruments.

3.3. High performance camera communication

Triggered by the ESPRESSO requirements a market survey was conducted to analyze current trends in CCD cameras communication. Again gigabit-Ethernet based communication has been an imposed initial strict requirement (as opposed to USB or Camera Link connections) due to limits in cabling scheme and possible re-use of existing network infrastruc-

ture. Among the very wide palette of products found, the cameras supporting the GigE Vision[®] protocol introduced in 2006 by (and supported by) the European Machine Vision Association presented a promising answer to cope both with high performance communication needs, as well as interoperability and interchangeability issues and thus could be seen as a valuable candidates for future E-ELT applications; further details could be found in (Baldini et al. 2014).

3.4. Unified architecture

OPC Unified architecture (OPC UA) is an industrial (standard) communication protocol developed by the OPC foundation aimed to connect various kind of systems and devices over TCP networks. The interoperability is achieved through a server-client approach: the server is (usually) supplied by the hardware manufacturer and represents the interface between internal proprietary protocols and OPC UA standard. Through the “server”, control nodes are exposed to outside world in a standardized way which could be then accessed by dedicated “clients”. The client implements the OPC UA communication by means of APIs and allows the user application to access the exposed nodes. By properly separating the client logic from the communication protocol, this approach guarantees full interoperability: devices from different vendors could be seamlessly exchanged without affecting high level software and, vice-versa, high level software could be improved and/or changed without the need to maintain the initial chosen hardware. This represent a big achievement if compared to the existing Paranal VME world and it is at the base of the chosen ESPRESSO control architecture (Baldini et al. 2014).

3.5. Device control

Among all the industrial trends analyzed in this paper the control of the devices will eventually depends on the technological choices imposed by the E-ELT. Therefore it is still premature to foresee or propose a definitive choice for the

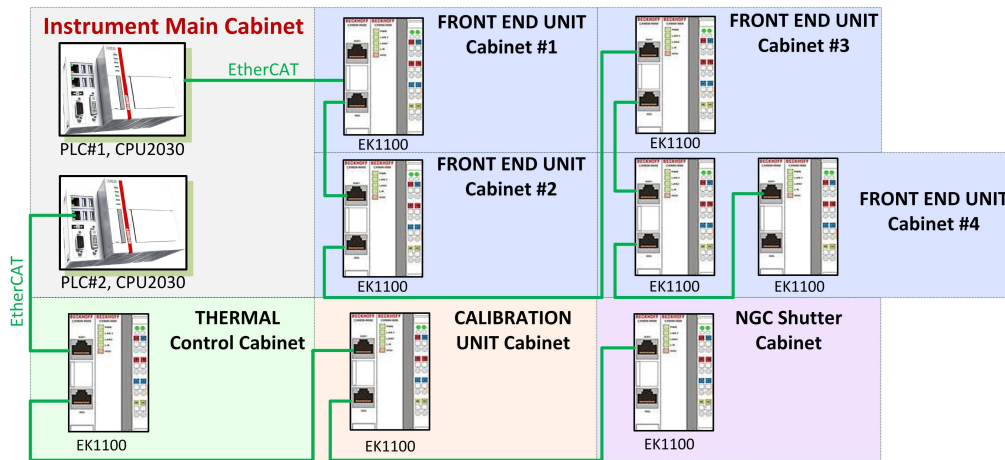

Fig. 2. ESPRESSO distributed control architecture based on fieldbus interconnecting Beckhoff Automation COTS components

control of the vital parts of an instruments (like motorized functions, lamps, sensors) considering also that a design of HiRes does not exist yet. Nowadays however, PLCs (Programmable Logic Controllers), are an example of wide spread devices used in this field and represent a valid choice also looking ahead. They are essentially a hard real-time systems where outputs are produced based in response of input conditions. The way outputs are done is fully programmable and this offer a huge flexibility allowing with the same PLC to control almost any functionality the system will require. PLC programming languages are standardized in IEC61131-3 open international standard; their usage coupled with the PLCOpen motion control standard specifications allows to write efficient and flexible PLC code that is vendor and product-independent as has been proved in ESPRESSO case (see Fig. 2).

4. From ESPRESSO to HiRes

All the technologies presented in this paper are currently in use in ESPRESSO which could

be reasonable seen as a precursor and test bed of HiRes@E-ELT. The main difference is that in HiRes several spectrograph modules (instead of one) are foreseen, but for the rest the overall conceptual design is quite similar: no movable parts inside the modules to guarantee ultra-stability and complex front-end for properly feeding the light. The ultimate lesson learned from ESPRESSO is that relying on COTS solutions adhering to widespread industrial standards lowers procurement and maintenance costs and seems the correct way to minimize obsolescence by guaranteeing product interoperability and inter-changeability.

References

- Baldini, V., et al. 2014, Proc. SPIE, 9152, 915228
- Duhoux, P., et al. 2014, Proc. SPIE, 9152, 91520I
- Ghedina, A., et al. 2014, Proc. SPIE, 9145, 914553
- Mégevand, D., et al. 2014, Proc. SPIE, 9147, 91471H