

Review

# Review of MVDC Applications, Technologies, and Future Prospects

Sophie Coffey <sup>1</sup>, Victor Timmers <sup>1</sup>, Rui Li <sup>1</sup>, Guanglu Wu <sup>2</sup> and Agustí Egea-Álvarez <sup>1,\*</sup>

<sup>1</sup> Department of Electronic and Electrical Engineering, University of Strathclyde, 16 Richmond Street, Glasgow G1 1XQ, UK; sophie.coffey@strath.ac.uk (S.C.); victor.timmers@strath.ac.uk (V.T.); rui.li@strath.ac.uk (R.L.)

<sup>2</sup> State Key Laboratory of Power Grid Safety and Energy Conservation, China Electric Power Research Institute, Beijing 100192, China; wuguanglu1989@126.com

\* Correspondence: agusti.egea@strath.ac.uk; Tel.: +44-(0)-141-548-2373

**Abstract:** This paper presents a complete review of MVDC applications and their required technologies. Four main MVDC applications were investigated: rail, shipboard systems, distribution grids, and offshore collection systems. For each application, the voltage and power levels, grid structures, converter topologies, and protection and control structure were reviewed. Case studies of the varying applications as well as the literature were analyzed to ascertain the common trends and to review suggested future topologies. For rail, ship, and distribution systems, the technology and ability to implement MVDC grids is available, and there are already a number of case studies. Offshore wind collection systems, however, are yet able to be implemented. Across the four applications, the MVDC voltages ranged from 5–50 kV DC and tens of MW, with some papers suggesting an upper limit of 100 kV DC and hundreds of MV for distribution networks and offshore wind farm applications. This enables the use of varying technologies at both the lower and high voltage ranges, giving flexibility in the choice of topology that is required required.

**Keywords:** medium voltage DC (MVDC); applications; distribution grid; offshore wind; rail; shipboard systems

**Citation:** Coffey, S.; Timmers, V.; Li, R.; Wu, G.; Egea-Álvarez, A. Review of MVDC Applications, Technologies, and Future Prospects. *Energies* **2021**, *14*, 8294. <https://doi.org/10.3390/en14248294>

Academic Editor: Adrian Ilinca

Received: 3 November 2021

Accepted: 6 December 2021

Published: 9 December 2021

**Publisher's Note:** MDPI stays neutral with regard to jurisdictional claims in published maps and institutional affiliations.



**Copyright:** © 2021 by the authors. Licensee MDPI, Basel, Switzerland. This article is an open access article distributed under the terms and conditions of the Creative Commons Attribution (CC BY) license (<https://creativecommons.org/licenses/by/4.0/>).

## 1. Introduction

Since the “Current War” between Thomas Edison and Nikola Tesla, AC has been the basis for electricity systems across the world for the last 100 years [1]. DC systems have been used for certain applications in the past, but their benefits could see DC replacing traditional AC systems in many situations. Compared to AC, DC systems have a better transfer capacity, improved flexibility and controllability, and are able to provide better power supply reliability [2]. Medium voltage DC (MVDC) could replace AC in several applications due to these benefits, which could be used, for example, in developing MVDC rail systems, integrated shipboard power systems, offshore renewable collection, distribution grids, the electrification of oil and gas rigs, DC homes, the electrification of university campuses, and mine sites. The first applications (i.e., rail systems, integrated shipboard power systems, offshore renewable collection, and distribution grids) are the most common applications in terms of both implementation and research literature. They were selected in this paper to give a significant overview of MVDC applications.

HVDC has been already implemented for transmission [3], but MVDC is increasingly being suggested for distribution in power systems. MVDC links have been implemented successfully between distribution grids [4,5], and MVDC collection systems could be utilised for offshore renewables, where they could be integrated with HVDC transmission links.

For rail systems, the lower end of MVDC (750 V to 3000 V) has been used in urban and suburban traction systems for several decades [6]. It has been proposed that these systems first be increased to higher MVDC voltages and power ratings to improve capacity [7] as well as to develop MVDC rail grids to achieve a performance that is equivalent to that of a 25 kV AC line [8].

Shipboard power systems have developed for use as integrated power systems (IPS) due to benefits such as flexibility of layout; reduced fuel consumption, maintenance, and emissions; and improved reliability [9]. Traditionally, these IPSs have been based on AC distribution, but the industry is now seeing a move towards DC systems [10].

MVDC has been suggested for these applications for the following reasons: firstly, there is an approaching limit of how much the transfer capacity can increase with the AC infrastructure [11]. For example, the result of growing populations in urban areas is concentrated loads, which increases the distribution capability and power supply reliability requirements. Furthermore, transportation and heating systems are increasingly using electricity, with the aim of reducing CO<sub>2</sub> emissions by utilising renewable energies, which creates further stress on the capacity of the distribution networks. In rail systems, increasing traffic in low and medium voltage DC systems is causing these systems to reach their limits [7]. Compared to the AC cables, DC cables have a higher transfer capacity, so converting existing AC lines to DC in distribution networks and rail systems would increase this capacity [12]. This could also benefit shipboard systems because of the reduced weight that is provided through the use of DC cables [13].

Furthermore, conventional AC systems often have radial and open-loop layouts, resulting in a lack of flexibility and controllability. This limits the implementation of distributed generation (DG), as their generated power is in a specific area, and it is not able to be supplied back upstream in times of excess power generation. Additionally, this lack of flexibility in AC shipboard system prevents excess capacity from being stored [9]. The power flow reliability is of vital importance in shipboard systems, and MVDC offers the ability to improve flexibility with integrated power systems and improved reliability [14]. The flexibility benefits of MVDC also aide rail systems, especially urban rail networks [15], by improving protection control [16], enabling flexible integration with distribution grids, and simplifying onboard energy conversions [16]. AC radial networks in distribution grids with DG could also result in over-voltages and congestion [17]; however, the ability of the distribution system to respond to uncertainty from supply and demand must be maintained [18]. DC distribution systems have more configurations, leading to improved flexibility for these applications.

MVDC grids would improve systems with a high penetration of DC loads and power converters. DC loads are continuously increasing, with up to 80% of loads in commerce and residential areas being DC [19,20]; therefore, utilising MVDC systems would reduce conversion stages. Modern ship systems also often utilise DC loads and pulse-loads; loads that draw a very high current in a short time over intermittent periods [21]. In rail systems, MVDC supply rails would also reduce the number of conversion stages required to supply the series-wound DC motors [8]. Furthermore, power electronic devices are becoming increasingly common in ship power systems [9] and in rail systems as well as to interface renewable generation in distribution grids. However, this results in control interactions with the AC distribution networks [22]. With these renewable sources being connected, their intermittency and uncertainty results in instability and control issues with AC grids [18,23]. MVDC links with back-to-back power converters creating a soft open point (SOP) are being suggested to combat this instability and reactive power issues as well as to increase the control flexibility [24,25].

There could be significant improvements in efficiency and cost if MVDC collection systems were utilised to integrate renewables, specifically wind power [26]. Moreover, for the devices that are required to connect to the transmission or distribution grids, the size of the collection systems and the conversion stages could be reduced using DC–DC converters, which enable MVDC systems with high gains to increase to high voltages [27].

Additionally, for shipboard electric systems, the size and weight of the traditional MVAC electric systems would be reduced, and the generators and heavy low-frequency transformers can be removed [10,13].

MVDC technologies have been suggested and/or implemented in rail, ship, distribution grids, and offshore collection systems; however, a comprehensive understanding of the usage of MVDC in the future is lacking in the literature. This paper aims to review a comprehensive set of MVDC applications and the overall network configurations, hardware, and topologies that are required for the discussion of the application implementation, case studies, future trends, and problems of MVDC applications. This paper highlights the maturity of the various MVDC applications, as they are at differing stages of development and technology readiness levels (TRL). This paper reviews the uses, advantages, and disadvantages of MVDC and offers a “cross sectional” review of common points in order to paint a full picture, which has been lacking in the literature. The sections are divided as follows: Section 2 provides an overview of MVDC applications in ships, rail systems, renewable collections, and distribution grids. Section 3 details the application of MVDC in distribution grids for active and reactive power control and for increasing system capacity and grid network topologies. Converter configurations and smart transformers are reviewed in Section 4, and protection and control are reviewed in Sections 5 and 6.

## 2. MVDC Applications

### 2.1. Sea

In traditional shipboard systems, diesel propulsion systems have a direct mechanical connection between the prime mover and the turbine, with the propulsion area being separate from the main power system [28]. However, in the 20th century, these systems began to be replaced with diesel–electric propulsion [29], where the diesel generator connects to an electric motor, as seen in Figure 1. This move towards electric systems was motivated by the flexibility of the layout; reduced fuel consumption, maintenance, and emissions; and improved reliability. However, up until the beginning of the 21st century, the majority of the power in the ships that were using these systems was solely dedicated to propulsion, [30], as well as for cargo ships and refrigeration [31], which required special electrical power system arrangements. In recent years, integrated power systems (IPS) have been proposed to replace standard mechanical ship propulsion systems, which use generators and battery energy storage systems (BESS) to supply the propulsion system and all other loads, no longer separating propulsion from the rest of the system [9]. IPSs could help pave the way for all-electric ships (AES), where all of the onboard equipment and systems are electrical, with generation being provided by electric storage [32].

Schuddebeurs et al., [32], categorises ship systems from diesel–electric to AES, highlighting development and direction in the industry. An IPS could improve flexibility, reduce the number of prime movers that are required, and increase efficiency; additionally, vessels of all sizes can utilise an IPS [31]. Standard AC ship system-rated voltages traditionally ranged from 690 V for small ships (e.g., passenger ferries with a generator capacity of 4 MW) to 6 kV, with total generator capacity between 4–20 MW and 11 kV, with a generator capacity above 20 MW (e.g., container ships and larger cruise liners [33]).

Initial AC distribution designs had separate propulsion and service load systems to prevent faults propagating. However, the disadvantage of this system is a lack of flexibility, and it is more efficient to amalgamate these systems. IPSs can be further improved with zonal distribution, which has been increasingly suggested in the literature [9,28,34] for increased reliability. The development of AC standard shipboard systems is illustrated in Figure 1.

However, the industry has seen a move towards DC power systems, specifically towards MVDC [10], for IPSs, as shown in Figure 2. AC ship power systems have disad-

vantages, with bulky transformers taking up important space and weight [13]. Furthermore, in traditional AC systems, the excess capacity from the propulsion power system when travelling at a low speed or when the vessel is stationary cannot be directly used or stored in BESS [9]. Another reason for the move towards DC systems is that power electronic devices are becoming increasingly common in ship power systems [9]. Modern ship systems also often utilise pulse-loads, which are loads that draw a very high current in a short time and over intermittent periods [21]. However, gas-powered AC generators have a slow response, which does not match the fast response that is required for the emerging pulsed loads [33]. On the other hand, energy storage devices (DC systems) as well as power electronics provide a fast response. DC networks also avoid the issues that are associated with the synchronisation of loads to sources and reduces voltage drops and power losses due to reactive power [35]. Therefore, BESS and possible renewable sources (RES) can be connected to the IPS. In AC grids, power quality issues such as the harmonics and frequency fluctuations that are caused by pulse loads and that are loads interfaced with power electronics are a system concern that require regulation in order to avoid risks to the ship and crew [9]. DC grids do not have frequency issues; however, they do have voltage stability issues [33]. Therefore, appropriate stabilising methods must be considered for MVDC distribution systems and power quality standards for DC grids that need to be defined [36]. A generic DC ship distribution network layout is shown in Figure 2 [37,38].

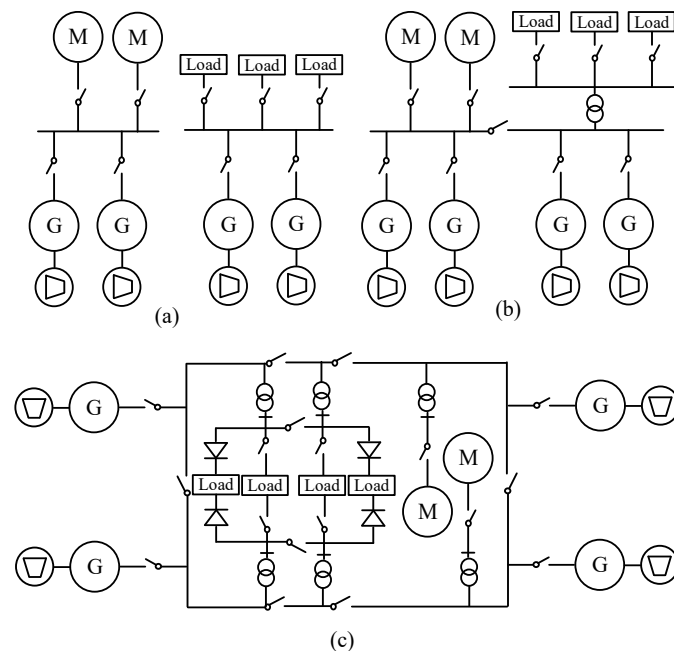

**Figure 1.** Traditional AC ship distribution systems: (a) propulsion isolated, (b) radial IPS, (c) modern AC zonal distribution system.

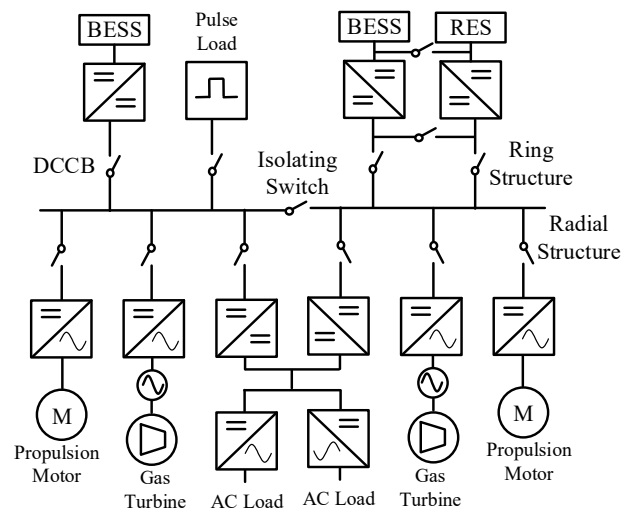

**Figure 2.** Generic DC shipboard IPS.

The network structure could be a radial, ring, or mixed structure [34]. Traditionally, AC ship systems were arranged radially, an orientation that has the benefit of simplicity; however, these structures lack survivability, as if a line is disconnected due to a fault, there are no other connections to the load to power it [9]. Several papers have highlighted the benefit of utilising an open ring bus structure [34,39]. This structure is capable of isolating a fault with a normally open point, therefore allowing the rest of the system to continue to operate. Furthermore, a ring bus structure ensures that a vital load can be powered from several points, improving security and reliability [33].

IPSs have been around for the last 30 years, with the Queen Elizabeth II being the first ship with an AC IPS [40]. Other IPS examples are Queen Elizabeth Class Aircraft Carriers [38], the Ellen E-Ferry, and the Yara Birkeland Autonomous container, an AES [41]. The QEC has four 11 kV switchboards and six generators, two at 35 MW, two at 11.3 MW, and 2 at 8.5 MW. The Ellen E-ferry is a 57 m medium sized car and passenger ferry with 4.3 MWh battery capacity with DC operation [42]. The Yara Birkeland is a 79.5 m long ship with an optimal speed of 11 km/h, and it is the first fully battery-powered and autonomous container ship. The battery pack of the propulsion system is 7–9 MWh [43]. All-electric ships are being suggested due to their better efficiency, fuel economy, power quality, and reliability [44]. Helgesen et al, [43], detail the advancements in electrical energy storage for ships and the extensive progress made in the field. The NORLED MF Ampere Ferry is the world's first electric car ferry, which uses battery storage; however, it is based on an AC distribution system [45].

## 2.2. Rail Systems

Since the 1950s, rail systems have been leaning towards electric rail in Europe, China, and Japan [8,46]. However, diesel and diesel–electric locomotives still exist in North American and some European countries. Electric trains are more efficient and do not produce greenhouse gases [47] and have a greater power to weight ratio than their diesel counterparts [48]. The installation costs of electric rail systems are significant; however, in busy lines, these expenses are negated by the reduced operating costs compared to diesel engines, as the cost of diesel fuel is significantly more than that of electricity [49]. However, in remote areas with little rail traffic, the installation costs are often too much to warrant system electrification. Such areas would have to rely on the development of large-scale rail battery storage systems in order to achieve electrification [49,50].

Electric rail systems across the world have historically been supplied with a mix of LVDC/MVDC for low speed and urban connections and MVAC for intercity and high-speed rail systems. In inner city areas, there are currently several LVDC/MVDC voltage

levels for various light rail operations in different countries; trams and subways use voltages between 750 V and 1.5 kV, and medium-distance trains use 3 kV DC [6]. With these DC systems, a three-phase AC distribution network would traditionally connect to a traction power substation (TPSS) containing a rectifier bridge for DC conversion. However, lower-voltage DC systems suffer from increased heavy traffic, preventing operation at nominal power, and the substations are required to be very close together.

For high-speed AC rail networks, step down transformers that are connected to the grid provide the catenary with medium-voltage AC, e.g., 25 kV/50 Hz, and VSCs on each train supply traction DC induction motors. AC rail distribution grids have been prevalent due to ease of connection to the main national grid through step up transformers to reach higher voltages and to reduce line losses, meaning that fewer substations are required and that AC technology is advanced and reliable, such as in AC circuit breakers [51]. Some European countries, such as Sweden, Germany, and Austria, maintain a low-frequency AC catenary voltage of 15 kV at 16.7 Hz [52], while most other European countries, such as Spain, France, and the UK, adopt an MVAC rated at 25 kV/50 Hz [46,53]. However, AC supply lines have certain drawbacks: reactive power compensation is required, single phase substations have a high short-circuit power in order to avoid voltage imbalance at the PCC, and the inductive voltage drops [54].

As a natural evolution of existing LVDC/MVDC traction systems, modern MVDC rail systems have been proposed instead of MVAC. High-speed DC rail systems were limited due to the significant voltage drops along DC lines, the required high number of expensive substations, and the lack of development of protection, [46] and only the LVDC and the lower end of MVDC voltage ratings could be utilised. However, there have been significant advances in these areas and in MVDC technologies [6], and future MVDC rail distribution grids are increasingly being suggested in the literature. Gómez-Expósito et al., [46], present a multiterminal MVDC network with a single uninterrupted 24 kV DC catenary. The main transmission grid supplies this MVDC distribution grid through a series of equally spaced substations containing multilevel VSCs. In Verdicchio et al. and Caron et al., [7,54], reviews of similar MVDC distribution structures are presented; however, the systems that are presented use two overhead lines. The former investigated the optimal distance between substations and compared operation to a real 25 kV AC line. The latter reviews the DC voltage levels of a bus system and suggests that a 9 kV DC supply has a comparable performance to that of a traditional 25 kV AC system. Verdicchio et al., [8], also agree with this comparison but adds that the selected DC voltage level must take substation distance, the rail to ground voltage, and the thermal constraint on the overhead line cross section into consideration, increasing costs. Thus, the selected voltage must optimise between thermal constraints and cost. References [55,56], Tobing et al. and Pereira et al., present optimisation solutions for the placement of DC traction substations to minimise voltage drops and power losses.

An example DC network is shown in Figure 3. The TPSS contains disconnectors on the AC side, rectifiers, and DC circuit breakers and disconnectors [6].

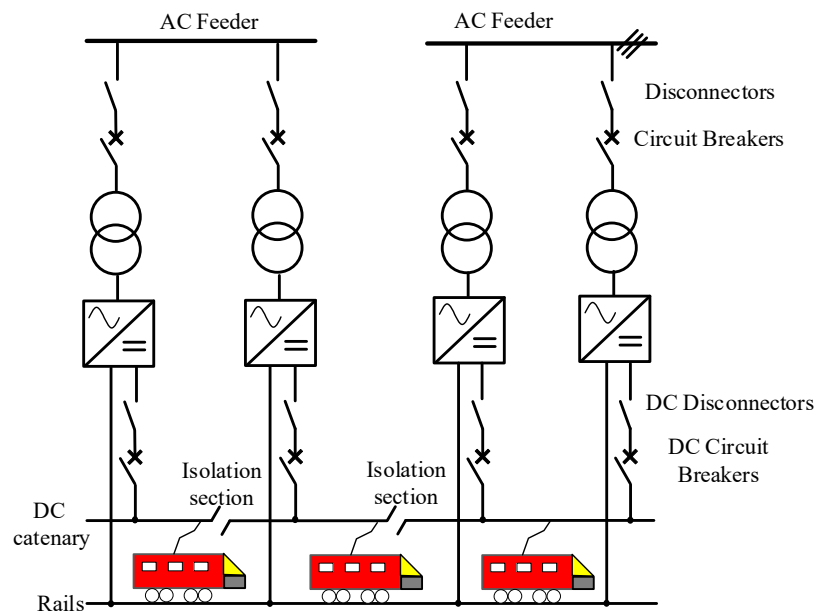

**Figure 3.** DC rail distribution system.

The substation control system controls the reactive power on the AC side as well as the active power and DC voltage. In areas where the lines are close to each other, rectifying stations could be removed and replaced with DC–DC links [46]. Further to this, modern MVDC rail might be reversible and integrate BESS [57].

There are still significant developments that are required in MVDC rail systems, such as those seen in [58]. Arcing in DC rail systems is intense, as the voltage is often lower compared to that of the equivalent AC systems, resulting in the current being higher [59]. Interruption between the pantographs and the overhead line can cause arcing and results in power quality issues, electromagnetic emissions, increased temperature at the contact point, and wear on the contact wire and strip on the pantograph [60]. Fast detection methods might be required to prevent the spread of negative electromagnetic phenomena throughout the rail network [61].

### 2.3. Offshore Wind Connection

Most current and proposed offshore wind farms use 33 kV or 66 kV AC cables in their collection system to connect the wind turbines together in strings [62]. For wind farms that are located close to shore—typically within 100 km—the power is exported using 220 kV to 275 kV AC cables, as shown in Figure 4a. Over the last decade, wind farms have moved further from the shore, and the use of HVDC in the export systems has become more cost-effective through the reduction of cable costs and losses as well as through the elimination of the need for reactive compensation [3]. This type of connection is shown in Figure 4b.

The literature demonstrates significant interest in the use of MVDC cables in future offshore wind farm collection systems [63–67]. The use of MVDC collector systems in offshore wind farms has been suggested as far back as 2003 [63] but have mainly remained theoretical over the last decade. Recently, however, cost reductions in power electronics and advances in DC control and protection have led to a renewed interest in MVDC-based wind farms.

The voltage conversion for these designs would be performed using DC/DC converters with a medium frequency transformer (MFT), as detailed in Section 4, which are significantly smaller and less heavy than the 50 Hz transformers that are used in traditional

offshore wind farms with HVAC or HVDC export systems. This has the potential to reduce the size and weight of the offshore platform. This design is illustrated in Figure 4c. In some of the proposed MVDC designs, the offshore platform, which can make up 20% of the offshore wind farm capital cost, is removed altogether [68]. This connection option is shown in Figure 4d.

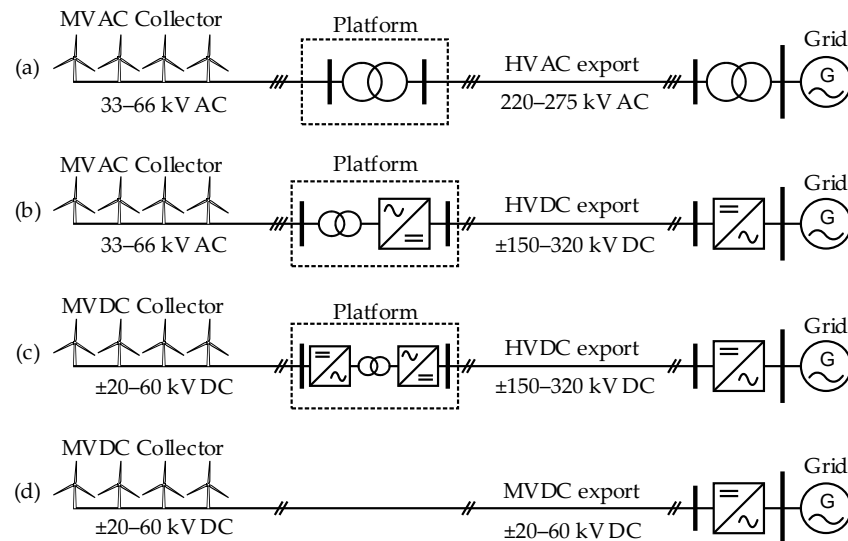

**Figure 4.** Connection options for offshore wind farms: (a) MVAC collector with HVAC export, (b) MVAC collector with HVDC export, (c) MVDC collector with HVDC export, and (d) MVDC collector and export. Indicative voltage levels are based on existing AC wind farms [69] and proposed DC wind farm designs [65,68].

A range of designs have been proposed for MVDC collection systems. The standard design consists of a parallel connection of the wind turbines, with each wind turbine containing a dedicated DC/DC converter with MFT to step up the voltage. The collector system voltage is stepped up at one or more offshore platforms with high power DC/DC converters, as shown in Figure 5a. This design is most similar to the AC radial collector systems, reducing the technological risk. However, it requires a large number of conversion stages and is dependent on immature DC/DC converter technology [66].

Variations in the parallel collector circuit include the centralised and dispersed parallel configurations. The centralised, also known as cluster, configuration performs the voltage conversion using string-level DC/DC converters, and the wind turbines use simpler drivetrains consisting of a 50 Hz transformer with an active or passive rectifier [65,70], as illustrated in Figure 5b. This configuration reduces the number of components and the maintenance requirements of the wind turbines but suffers from losses due to the turbine speeds being controlled at the string-level [65]. The non-standard wind turbine drivetrain also increases the technological risk. The dispersed configuration takes the opposite approach, where the parallelly connected wind turbines use individual DC/DC converters to boost the voltage to high levels, and a central converter is omitted [71], as shown in Figure 5c. This allows the offshore platform to be much smaller or even removed. However, the wind turbine converters are unlikely to be able to reach the same voltage levels as the other designs, leading to higher transmission losses.

Several papers propose that the wind turbines in a DC collection grid be collected in series [63,72]. This configuration allows the wind turbines to build up the voltage to transmission levels, removing the need for an offshore converter platform. This has obvious cost benefits that are the result of halving the number of required cables and removing the offshore platform. However, since all wind turbines form a single string, any fault on the



collector circuit results in the complete loss of power output [72]. The series–parallel configuration is therefore proposed by a number of papers to increase the wind farm availability [73,74]. This design consists of multiple strings of series-connected wind turbines, as shown in Figure 5d. However, both the series and series–parallel designs have several operational and technological challenges that need to be overcome in order for them to be commercially feasible. All of the wind turbines in a string must maintain the same current output, and the transmission voltage is dependent on the wind turbine power production, resulting in challenges in balancing the voltage and reductions in efficiency [75,76]. The wind turbines in each string must also be capable of withstanding transmission level voltages, which require novel wind turbine designs [72].

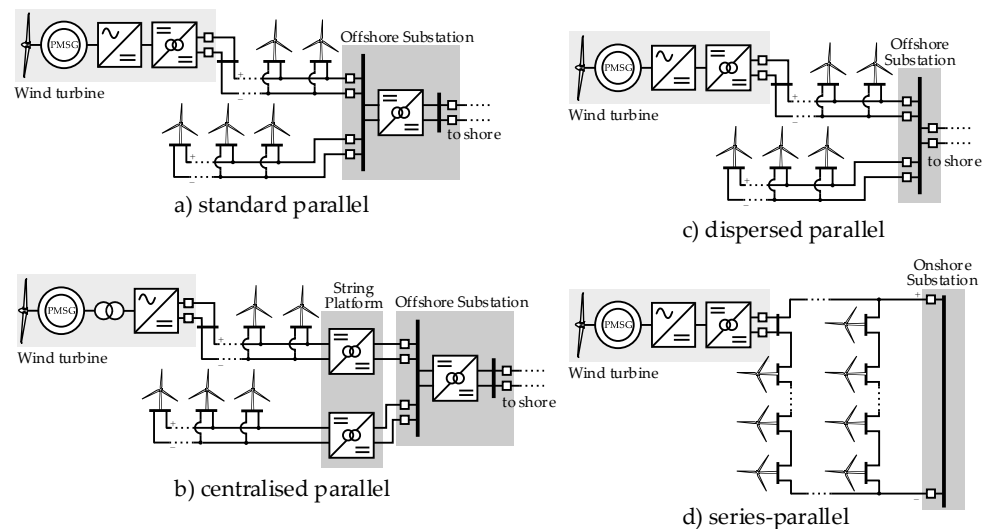

**Figure 5.** DC collection system options: (a) standard parallel, (b) centralised parallel, (c) dispersed parallel, (d) series-parallel

#### 2.4. Network Distribution Grid Systems

The distribution grid has predominantly been AC since the early 1900s and the “Current Wars” between Edison and Tesla [1]. AC technology has been utilised due to the ease at which it can be increased higher voltages with transformers, allowing for reduced power losses. However, developments in VSCs and protection and semiconductor devices have enabled the introduction of HVDC transmission, paving the way for further DC connections, such as MVDC distribution.

The importance of power reliability and quality in cities and urban areas is paramount, but as populations increase and the strain on the power supply is exasperated, extra capacity will be required in the distribution grid. However, the AC system is steadily reaching its limit, as the space for new substations and lines is finite. The transfer capacity of a DC conductor is about 1.5 to 1.8 times that of an AC cable with the same width and current [12,77,78], and it also has a higher efficiency [79]. DC also uses its full peak-voltage capability compared to RMS, and DC does not suffer from the skin effect [20]. Therefore, MVDC could provide the increased voltage and capacity required in congested areas by converting MVAC lines to MVDC.

Another disadvantage of AC systems is the required reactive power compensation. Utilising DC allows for the removal of the three-phase balance or compensation requirements of AC [23]. DC cables do not consume any reactive power, and the power converter connections between the DC and AC grids could provide support and voltage control to AC systems.

Connecting distributed renewable energy sources to AC grids also creates challenges for the distribution grid. DGs are intermittent and unreliable, so BESS are required for

excess storage and support; connecting these to an MVDC would allow for simpler conversion stages than AC [20]. Controlling voltage disturbances is a significant goal of DG connections, and power converter control with MVDC systems can provide DG voltage control [80].

MVDC is not simply HVDC downscaled. MVDC could significantly aid in areas where there are no high-voltage connections and where high-voltage infrastructure could not be easily implemented, in densely populated urban areas, for example. Following this, HV has a large visual impact of high lines and power towers, and obtaining permits for HV corridors is becoming increasingly more difficult [81]. Furthermore, MVDC has the adaptability to allow for smaller, less expensive converters at the lower voltage ranges [82].

However, MVDC grids have several challenges to overcome; protection systems and DC circuit breakers need further development, there is a general lack of standardisation, and DC installation costs are currently high due to the power converters that are required [79]. Power converters are also still not as efficient as AC transformers and have a lower lifespan [20].

Furthermore, MVDC networks have no current zero-crossings and low DC impedances [83], resulting in the fault current being high. It is predicted that dealing with short circuit currents will be of great difficulty in DC grids [84], and compared to AC systems, the protection in DC systems will be much more complex [79]. Fault detection and location is a difficulty in DC systems, and detection methods are highlighted in the literature [61,85]; however, further developments are still. Further to this, the protection methods that are included in DC systems have yet to be standardised, and the best prevention methods are still up for debate; for example, there is still debate surrounding the use of hybrid or solid-state circuit breakers. Protection issues and the developments that are required to accommodate these issues are detailed in Section 5.

### *2.5. Applications Overview*

The four main applications that are overviewed are briefly summarised below in Table 1, which details the average voltage and power levels, technology readiness level (TRL), maturity, case studies, and available technology.

For rail systems, the lower end of MVDC technology is already in use for tram, metro, and subway systems; however, long-distance travel with MVDC is being suggested at higher voltages of around 10 kV and at high speeds of 20–30 kV.

For shipboard IPSs, MVDC power systems are emerging as an alternative to AC systems with heavy transformers. As reducing weight is highly important in ships, the benefits of MVDC power electronics are being utilised, especially as the voltage of DC buses will be required to be 5–35 kV (depending on ship size); therefore, significantly large onboard substations are not required [10,34,86].

Distribution grids are beginning to introduce MVDC links and DC grids. There are several examples of DC links [87,88], and small DC distribution networks have been developed in Southeast China [89,90]. The technology that is present in distribution grids is available as MVDC systems, which have the flexibility of utilising 2L and 3L VSCs, as well as modular multilevel converters (MMCs). The suggested voltage range for distribution operation varies in the literature, with some papers suggesting 1.5–100 kV [78], and others narrowing the range to 5–50 kV [26,91]. For projects [4,5,90,92], the voltage ranges from 10 kV to 27 kV. This will likely be the mean range for distribution, but there may be some extension up to 50 kV or even to 100 kV for a distributed renewable connection.

However, offshore wind collection is still being developed, and there are currently no active MVDC collection systems. The lower weight of MVDC collection substations compared to AC collection or HVDC systems would also significantly reduce the capital cost of the system. MMC technology could achieve the high step-up ratios that are required, and this technology has good short-term reliability with active redundancy, but

the long-term survival of the technology in offshore conditions is still being investigated [93].

The range of the MVDC voltages that are required for various applications have not been standardised. The values that have been suggested in the literature or that have been implemented differ, with Table 1 showing these details. To further represent the variation in voltage levels, the suggested and implemented applications are displayed in Figure 6 and are represented as a function of the year. The trends show that for rail systems, the lower end of the MVDC voltages (600–1500 V) have been implemented up to the 2010s, and from 2010 to the present day, higher medium ranges (9–24 kV) are being suggested to match those of the 25 kV AC rail systems. With distribution, the most commonly suggested and implemented voltage was 10 kV, with an outlier of the ANGLE-DC project reaching 27 kV. The most commonly implemented voltage for shipboard systems was also 10 kV; however, the suggested values have a larger range due to the variety in ship sizes and in the required loads. Finally, the suggested wind offshore collection platform voltages are in the higher range of MVDC values (20 kV–35 kV).

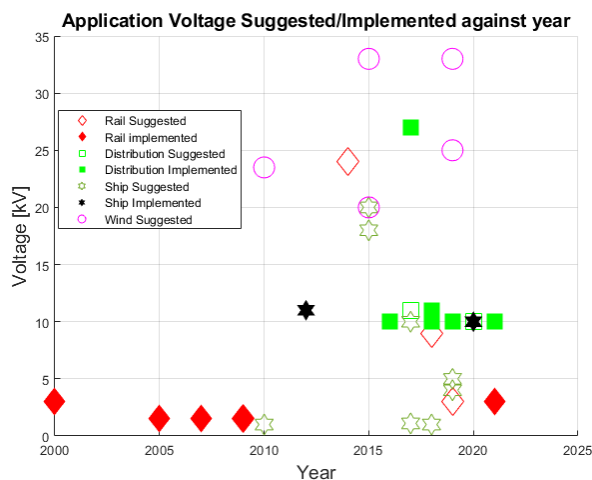

Figure 6. Suggested and implemented application voltage level.

Table 1. Application overview.

	Application			
	Railways	MVDC Distribution	Offshore Collection	Shipboard Systems
Voltage levels	600 V–3 kV (trams, suburb trains) Long distance 9 to 10.5 kV [7,8] High speed DC 20–30 kV [46]	5–50 kV [26,91,94,95] ±10 kV [5,89,90,92,96] 1.5–100 kV [78,97,98] ±10 kV to ±70 kV [99]	Typically ±25 to ±50 kV [75]	5 kV main bus voltage [13] 1–35 kV [86] 10 kV [10,34]
Power	3 to 5 MW suburban [6] 12 MW higher speed [54]	3 MW–200 MW [100,101] Common mid-range 10–20 MW [5,90]	160 MW to 1200 MW [63,72,102]	2–7 MW [37] (smaller ships) 10–20 MW (cruise liners) [33]
TRL	9	9	5	9
Maturity	Already utilised for tram, subway, metro travel. HVDC converters already capable of implementation, with SSCB and	Utilised in several countries in test phase: UK, China, Finland. Range of developed converter, semiconductor, and control systems by industry,	Relying on DCWT development [75], but many countries with large installed offshore capacity and MVDC technologies.	Integrated DC power systems are beginning to dominate the market. Light-weight MMCs and power elec-

	improved power semi-conductors offering new voltage capabilities.			tronics replacing heavyweight transformers. Improving battery capacity.
Cases	London Underground, Bordeaux-Hendaye intercity line, Paris-Strasbourg high speed line.	ANGLE DC SPEN, Zhuhai Distribution Project, Shenzhen MVDC [89], Suzhou [90], Hangzhou Jiangdong, Guizhou [44]	None implemented [75]	ForSea Ferries [103], Yara Birkeland [41], QEC Aircraft Carriers [38]
Available technology	Siemens MVDC plus [95], RXHK Smart VSC-MVDC transmission	Siemens MVDC Plus, RXHK Smart VSC-MVDC transmission	Siemens MVDC Plus	Energy storage systems, power management systems, voltage drives [103,104]

### 3. MVDC for Grid Connected Applications

#### 3.1. Applications

According to CIGRE [78], future MVDC distribution systems will be for interconnection with MVAC grids and for connecting LVDC systems and HVDC ones. The AC system will operate with the DC system, providing ancillary services and support. There will be a combination of structures: point to point DC connections, multiterminal MVDC grids, microgrids, and distributed generation connections. This section reviews the main applications for grid-connected applications.

##### 3.1.1. SOPs, FACTS and DC Links

AC distribution systems often utilise a radial structure, where entire sections of the line are isolated after a fault, causing downstream supply loss [25]. It is possible to connect two adjacent independent feeders to offer electricity supply routes in case of an unplanned outage [88]. This can be achieved using standard mechanical switchgears that are also known as normally open points (NOP). As an alternative, this connection can be realised through back-to-back MVDC VSCs, which are known as soft-open points (SOP) [24,105]. An SOP has the advantage of allowing AC grids to be decoupled from each other, due to the power quality of the short circuit ratio, for example [106]. At the same time, it can provide voltage support and active power control [24,25]. SOPs can be understood as a standard back-to-back topology, as seen in Figure 7a [25]. SOPs are already being trialed; reference [92] details a 11 kV flexible power link connected to two 33 kV AC distribution networks and that has SOPs and SPBs being installed on the network [107] (Figure 7b). Following SOPs are soft-power bridges (SPBs), which perform a similar function to SOPs; however, they can process less power, reducing the number of power electronics, taking advantage of a series-parallel connection [88].

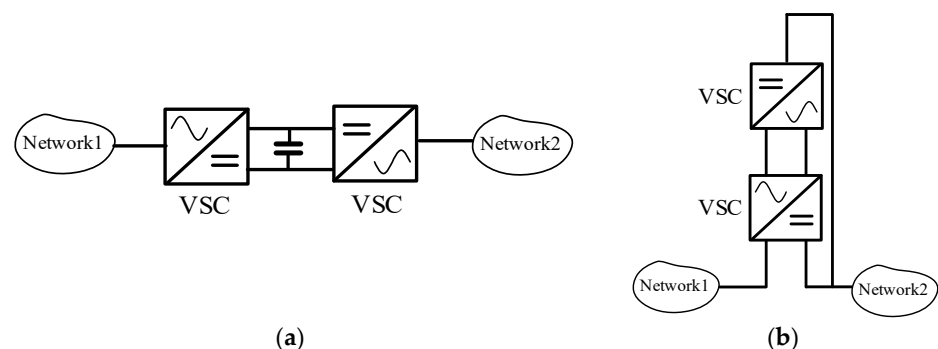

Figure 7. (a) B2B soft-open point configuration. (b) Soft-power bridge.

Flexible AC transmission systems (FACTS) have been traditionally used to improve power balance and voltage regulation in AC transmission power networks. Standard FACTS such as STATCOMs have been extensively used and have been specifically designed to suit the network needs such as voltage support or power flow control [108]. Medium-voltage level power electronics have been suggested to provide the same services for MVAC distribution [25].

MVDC can be also used to interconnect to distant nodes using a DC line or link. Several MVDC links have been suggested between two medium voltage nodes, such as in the ANGLE-DC project [109], which use a bidirectional MVDC link to improve power flow, allow control, release power capacity, and ensure reactive power control [24,87].

### 3.1.2. DC Distribution Networks

As MVDC technology continues to develop in terms of protection, converters, and reduced cost, full DC grids could be connected to AC systems instead using single SOP or DC lines [106]. At the same time, MVDC distribution networks might be a convenient solution as the loads shift from AC to DC. Consumer loads are increasingly DC, with up to 80% of commercial and residential loads currently being DC [20]. MVDC networks can easily integrate LVDC loads, such as those that are required for electric vehicles or future electrified transport systems.

MVDC distribution networks have started to be developed, especially in China. In Zhuhai, a  $\pm 10$  kV MVDC distribution system has been implemented [5]. A star network topology with three converters has been suggested to improve the reliability of the AC distribution network.

There are several further MVDC projects that have been or that are currently being developed in China's southeastern provinces. The Shenshen VSC-DC-based multiterminal hand-in-hand distribution system in Shen Zhen has been under development since 2014 [89]. The Hangzhou MVDC project will also utilise a multiterminal structure, as will the Guizhou project [96]. The Suzhou MVDC project has a more complicated system and is designing a single bus double-terminal ring structure. This is to combine the traditional ring structure and radial structure benefits [90]. Although the structure of these projects and that of the Zhuhai project vary, they all utilise MMC converters and operate at a DC voltage of  $\pm 10$  kV. This could suggest a standardisation of voltage in Southeastern China for MVDC.

### 3.1.3. Microgrids

Microgrids and smart grids have been proposed to integrate distributed generation to meet local energy demand and to connect to distribution networks without the costly expansion of the centralised utility grid. Microgrid grid structures and hardware topologies are very similar to the distribution topologies that are discussed in the next section and are often in the lower voltage ranges [110]. According to some sources [1,84,110], DC microgrids are set to take the dominance of AC microgrids, as the price decreases due to their ease of integration or renewable sources, which have better integration efficiency, DC load integration, no harmonic oscillations, no skin effect, and no synchronisation requirements [110]. MVDC microgrids will be prominent in offshore oil rigs [20], data centres [106], industrial applications, and EV charging stations. Offshore oil drilling often takes place in geographically remote locations, and at these locations, offshore wind generation is a significant resource. However, the lack of electrical collection systems linking generation and transmission at these locations prevents implementation. Oil drilling platforms could be electrified using an MVDC architecture and could also act as a wind generation collection system [86].

However, there are several issues that are associated with DC grids that are often overlooked, particularly in such DC microgrids. Firstly, power quality standards need to be defined for DC microgrids. Reference [36] provides power quality indexes for DC grids, as DC grids can be prone to electromagnetic compatibility issues, source and load

interference that cause flicker and fluctuations, low-frequency oscillations propagating between connected AC grids, and the impacts of overheating and aging. Furthermore, DC microgrids require significant protection that is different from the protection that is required for AC microgrids. DC lines have low impedance, resulting in the frequency of short circuits increasing quickly and high-fault currents and difficulties using traditional current relays from AC grids. AC CBs also cannot be used in DC grids, as they interrupt the current at the zero crossing, which a DC current does not have [84].

### 3.2. Grid Topologies

There are several topologies for MVDC distribution systems: radial, meshed, multi-terminal hand in hand, ring [111], or a combination of these (see Figure 8). The topology that is selected depends on the design requirements. Radial topologies are more economical due to a smaller conductor size and the placement of that conductor further along the feeder [112]. However, they are not very reliable, and a fault at the beginning of one feeder will cause supply failure to the rest of the connections leading from it. The power flows in one direction in a radial configuration, which could limit the flexibility of additionally distributed generation [113].

Ring structures have fewer voltage fluctuations at the consumer level and provide a reliable system, as the loads are fed from two feeders. The open-ring loop structure has NOPs between the two feeders that separate the loop into two radial feeders. During normal operation, the sections are not connected, but during a failure, the switch closes, and the section is energised from the other side. Ring structures can provide flexibility and reliability, as there are multiple paths for power flow [114]. Further to NOPs, normally closed-loop (NCP) configurations allow for a load to be balanced between feedings, improving power supply reliability [24].

Multiterminal MVDC networks have been proposed for use in microgrids, distribution systems and renewable collection systems in the literature [26,115–117]. Multiterminal networks are systems that do not contain a loop. MVDC networks connecting multiple MVAC grids would provide voltage support, power quality, and flexibility [118]. Multiterminal systems can be extended to more readily than ring networks can and offer the ability to intertie multiple networks at one point [119,120]. The protection and control of multiterminal MVDC networks need further research and development due to the inherent instability of MTDC VSC-based systems [115].

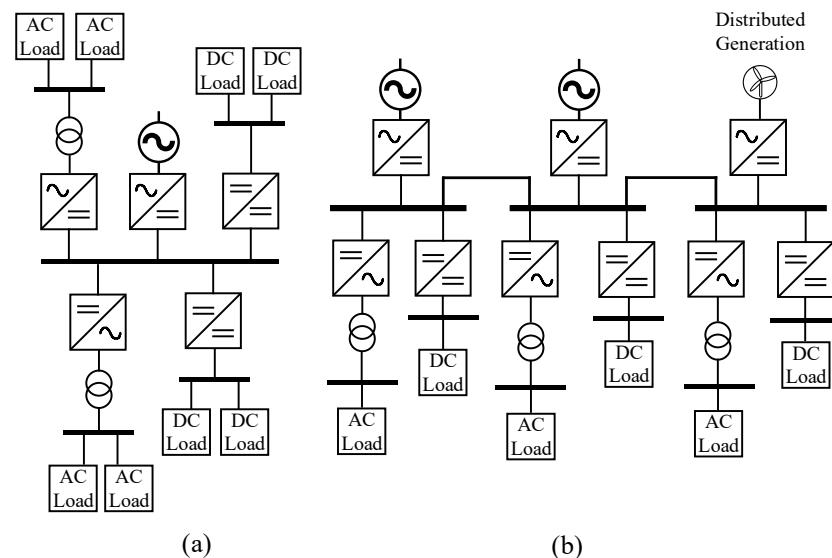

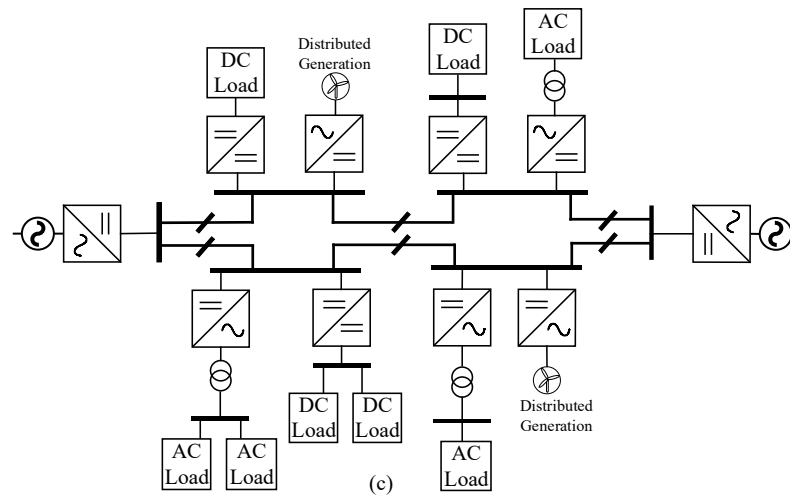

Figure 8. Network topologies: (a) radial, (b) hand-in-hand multiterminal, and (c) ring.

There are three main bus structures for MVDC networks [121]: unipolar asymmetric, unipolar symmetric, and the bipolar structure (see Figure 9). Unipolar symmetric systems consist of a single conductor and a ground return, and the symmetric structure uses two conductors. This symmetric structure is preferred in MVDC systems. On the other hand, bipolar buses might be able to run with two cables, but if one of the poles fails, it is possible to keep it running by considering a grounded or metallic return.

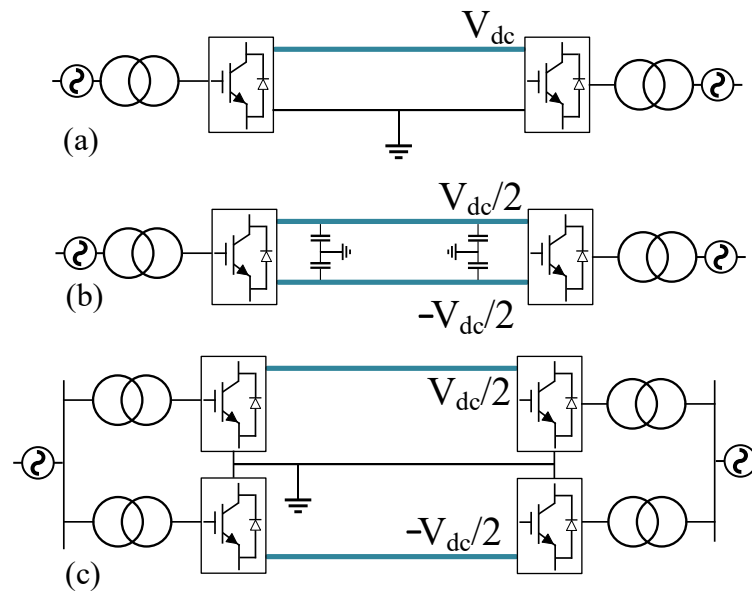

Figure 9. MVDC bus structures. (a) Unipolar asymmetric. (b) Unipolar symmetric. (c) Bipolar.

#### 4. Hardware

Each MVDC application has specific hardware requirements, and the development of AC–DC converters, DC–DC converters, solid-state smart transformers, and semiconductor devices are all at varying levels. This section presents the available topologies, the voltage range over which they are considered, and the advantages and disadvantages of each.

#### 4.1. Converters

##### 4.1.1. AC–DC and DC–AC Converters

The topology that is selected for MVDC converters is dependent on the requirements of their intended application. For AC–DC conversions, there are several topologies that are available, including diode rectifiers, line-commutated converters, shown in Figure 10, 6-pulse and 12-pulse thyristors bridges, 2-level (2L) VSCs, 3-level either neutral point clamped (3L-NPC), (Figure 11) 3-level flying capacitors (3L-FC) [122], alternate arm converters, 5-level converters, and modular multilevel converters (MMC) (Figure 12).

Rectifiers have been utilised for AC–DC conversion since the late 19th century. Railway traction substations have utilised the simple 6- and 12-pulse diode rectifiers for decades, and this converter is utilised in many rail systems today [15]. However, this basic diode rectifier suffers from a lack of regenerative braking capabilities and high harmonic current injections.

Shipboard systems traditionally used thyristor-based rectifiers at the medium voltage level, usually at about 20 kV, due to their significant robustness [99]. Generally, the 12-pulse thyristor rectifier is utilised, and it can remove the 5th and 7th harmonic, however, the lower order harmonics are still included [123].

For power transmission, line-commutated converters (LCC), as those shown in Figure 10, were widely used for long-distance high-power transmission and asynchronous grid connections [124]. LCC devices were implemented during high-power transmission to enable HVDC; however, this resulted in poor voltage regulation and commutation failure when operating under weak grids. This led to the development of the voltage source converter (VSC) for VSC-HVDC links in 1997, which used IGBT-based switching instead of thyristor pulse switching [125]. Since then, the modular multilevel converter (MMC) and several other multilevel or cascaded converters have been developed for improved sinusoidal outputs, reduced switching losses, and harmonics.

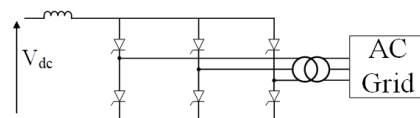

**Figure 10.** Line-commutated converter.

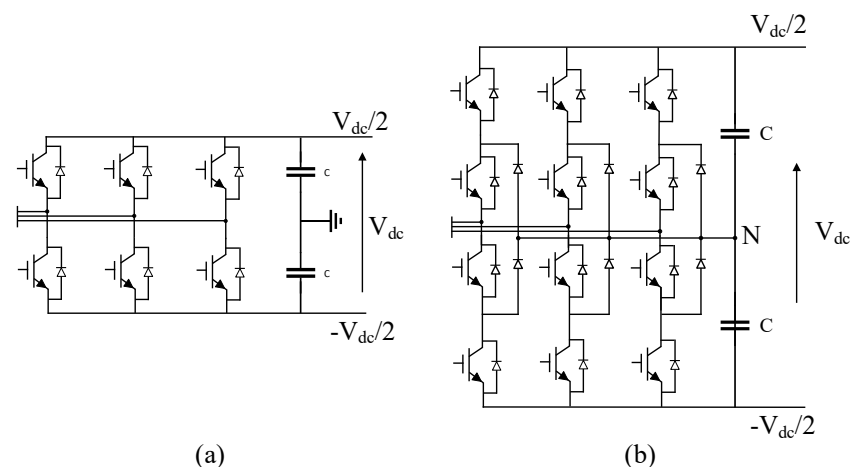

**Figure 11.** (a) Two-level converter (2L). (b) Three-level neutral-point clamped converter (3L-NPC).

The 2L and 3L VSCs are the ones that are the most commonly used in MVDC systems at the lower voltage range, e.g., 3–6 kV [126], due to the significantly lower cost and efficiency at these voltages compared to MMCs or other multilevel converters. The 2L VSCs can be considered at voltages of up to  $\pm 28$  kV DC [93], and the 3L-NPC can be considered



for voltages of up to  $\pm 35$  kV; however, MMCs are generally the best topology for higher voltage ranges that are above 10 kV [19,95,126,127], but at this voltage boundary, the converter should be selected on a case-by-case basis. MMCs possess benefits such as low distortion, modular design providing scalability [128], voltage balancing across switches, reduced harmonics, lower switching frequencies [127], improved fault ride through capability [108,129], and active redundancy, all of which significantly improve reliability [130,131]. However, there are disadvantages to MMCs, such as the cost that is introduced by sub-module redundancy and significant losses in the full-bridge (FB) configuration. [99]. In shipboard systems, the size and weight of the equipment is a crucial factor that should be as low as possible, and reliability is also required. The MMCs in shipboard systems offer scalability with voltage and power [10,132]. Soman et al. and Bosich et al., [10,101], review power densities and weight reduction benefits of the standard 12-pulse thyristor rectifier, IGCT based converters, MMCs, and 2L VSCs.

A basic outline of the MMC topology is shown in Figure 12 [133–135]. There are several possible submodule topologies, including the half-bridge (HB), full-bridge, and five-level cross connected modules. The HB submodule in MMCs has a lower power loss compared to the FB [93,136], and several papers solely consider HB MMC configurations [99]. However, the FB module has fault blocking capabilities [132,137]. There has also been a focus on the development of advanced semiconductor devices in converters for reduced power losses. The authors of [138] review the benefits of hybrid MMCs that use both SiC and Si semiconductors, and [137] reviews the effects of varying FB-HB configurations for varying switching devices inside of the MMC.

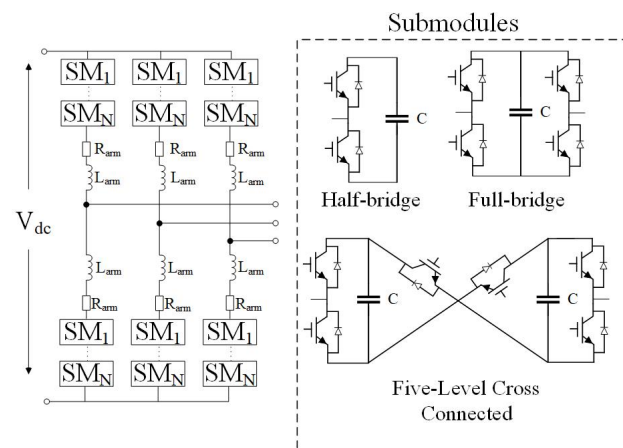
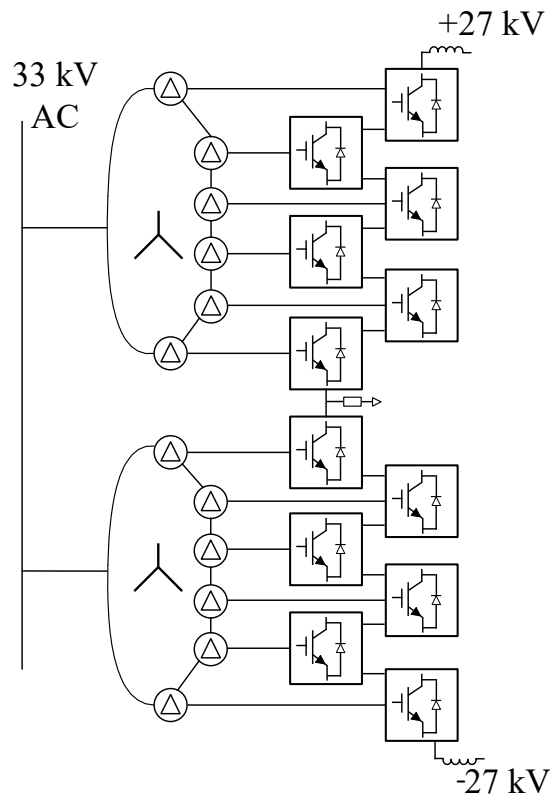

**Figure 12.** MMC and submodules.

Commercially, there are many considerations for converter topologies. In the Network Equilibrium FPL project, 3-level 3.3 kV converters based on IGCT technology were utilised to connect the 33 kV DC link [92], and in planning the ANGLE-DC MVDC project, 3L-NPC AC-DC converters were utilised to establish the connection between the 33 kV AC bus and  $\pm 27$  kV DC link [94], as shown in Figure 13. To implement this conversion, 12 of these converters were to be installed at each substation, achieving a conversion from 33 kV AC to 27 kV DC [87,99]. Comparing this modular converter configuration to the one seen in Figure 12, the individual transformers and the associated power losses could significantly affect total losses and cost. This series of cascaded converters is not the same as that of the traditional MMC or the ABB alternative to the MMC, the cascaded two-level converter [140], which was designed for VSC-HVDC transmission.

The planning of an MVDC distribution network in Zhuhai [5] opted for MMCs, where the Jishan I substation was not equipped with a DC breaker, so an MMC with self-

fault clearing ability was required. For this, an IGCT cross-clamped (ICC) MMC was designed with both FB and HB submodules.



**Figure 13.** Converter station configuration of Angle-DC Project.

#### 4.1.2. DC–DC Converters

DC–DC converters have multiple uses in MVDC applications. They can be used to establish connections from offshore wind farms, can be used in smart transformers, make it possible to increase or decrease MVDC links to HVDC links, and can be used in ship systems and rail connections. MVDC distribution projects are already introducing medium-voltage level DC–DC converters [5,89,96].

DC–DC converters can be divided into two groups: isolated and non-isolated. With the former, the input is isolated from the output with coupled inductors or AC transformers, offering galvanic isolation by creating a magnetic pairing. This protects the low-voltage side from the high-voltage side [141]. Isolated converters can offer larger step-up or step-down ratios and can allow for multiple DC outputs without significant cost [142]. Insulated converters can also improve efficiency, reduce switching losses, aid grounding, and result in low-voltage and current switching stress [143]. Non-isolated converters remove the transformers and use fewer semiconductor devices, which reduces switching losses, size, and cost, but they cannot provide large voltage ratios [141], the simplest topologies of which are buck, boost and buck-boost (Figure 14) converters.

There are several topology options for DC–DC converters, and the main suggested (isolated) topologies are the dual active bridge (DAB) and the dual active bridge resonant converter (Figure 15); cascaded DAB converters, and modular multilevel DAB converters (Figure 16); and (non-isolated) modular multilevel DC–DC converters (MMDC), which are shown in Figure 17. The well-known non-isolated buck, boost, and buck-boost (Figure 14) converters [143] are also utilised for low-voltage DC–DC connections, such as in light rail [57]. For this application, particularly with state-of-the-art battery driven light rail, a

bidirectional buck-boost topology is utilised to aid in regenerative braking. However, for high-power applications, these aforementioned devices are not well-suited and cannot achieve high enough step-up or down-ratios, and as the duty cycle is increased, the efficiency of the device begins to decrease significantly [142].

There are multiple DAB and DAB-resonant topologies presented in the literature, all of which show diverse benefits, e.g., high efficiency [141], high power densities, and bidirectional flow [144]. Balsamo et al., and Castellan et al. in [35,37] emphasise the importance of the bi-directional capabilities of DC–DC converters for battery storage and ultracapacitors in ship systems. Furthermore, DAB-resonant converters can operate at high frequencies [145], allowing for reduced magnet and capacitor sizing. Soft-switching is achieved with this configuration [146], reducing switching losses and noise [147]. Resonant topologies, however, can experience greater stress on switching and passive components [148]. Bidirectional DAB-resonant converters have been recommended to establish a connection between the charging station and the MVDC grid [145], and for the soft switching capabilities, galvanic isolation and high efficiency are recommended [147].

Multilevel modular DC–DC converters can be implemented with an AC link between the DC–DC input and output, which is also the case with the DAB MMC or with a direct DC–DC architecture, as illustrated in Figures 16 and 17, respectively, where the symbol SM signifies the submodule. A multilevel architecture allows for higher voltage gains for connections to distribution systems [27,149]. DAB MMCs can handle high power and DC voltage and have DC fault-blocking capability, with isolation benefits [150].

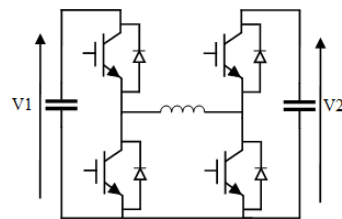
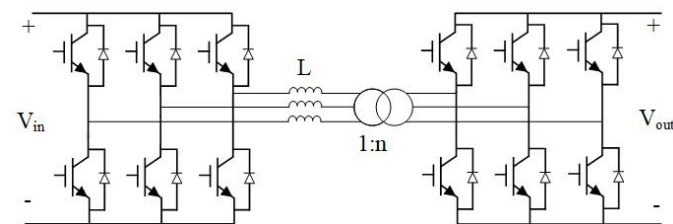
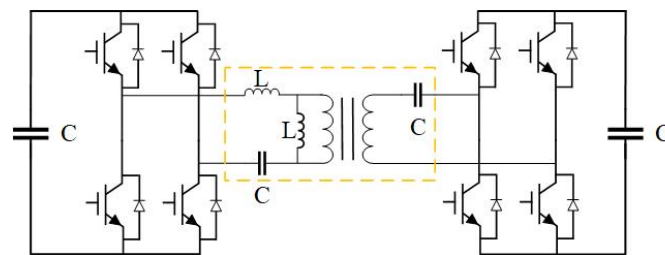

Figure 14. Buck-boost.



(a)



(b)

Figure 15. (a) Dual active bridge (DAB), (b) DAB-resonant converter.

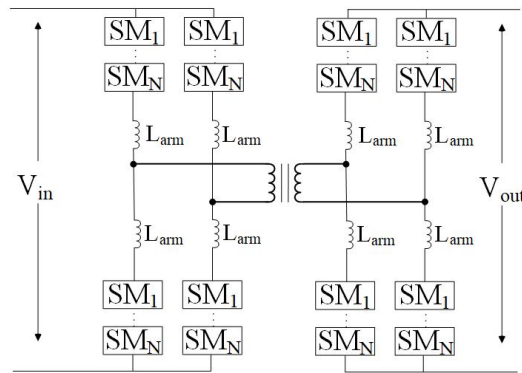

Figure 16. Dual active bridge modular multilevel converter.

The non-isolated MMDC can be separated in two categories; the push–pull and the tuned filter topologies, shown in Figure 17, where *SM* represents the sub-module [151]. The tuned filter requires more filtering than the push–pull [141]. Several papers recommend that high-power application DC–DC converters utilise a modular multilevel structure due to the high step-up ratio [37,152], enabling near sinusoidal ac waveforms, compact size, and low switching losses [148]. Such converters allow for large single stage step up/down conversions due to their multilevel and modular nature [153] and DC fault blocking capabilities [141]. The MMDC offers higher efficiency than the DAB-MMC at lower-voltage step-up ratios, but this efficiency drops as the transformation voltage is increased [141]. Furthermore, MMDCs have significant reliability, as they utilise active redundancy, which is important in offshore applications. However, the voltage balancing control of the MMDC is considered complicated [154], and active redundancy results in a significant number of semiconductor devices being required and available at increased costs. The reliability of the MMDC is significantly greater than that of the DAB due to active redundancy; however, in terms of grid connections, the importance of this factor has to be weighed with the other parameters. Grid substations are easy to access and also do not face the harsh conditions that an offshore collection platform would; therefore, reliability might not be of the same importance for DC grids [155]. In terms of MVDC to HVDC grid connections, the benefits of both DAB-MMC and the MMDC make them recommended for use in varying scenarios. The galvanic isolation of the DAB-MMC provides guaranteed fault blocking capability, yet the non-isolated MMDC with FB sub-modules can prevent fault propagation and are generally recommended for lower step-up ratios between MVDC and HVDC grids [141].

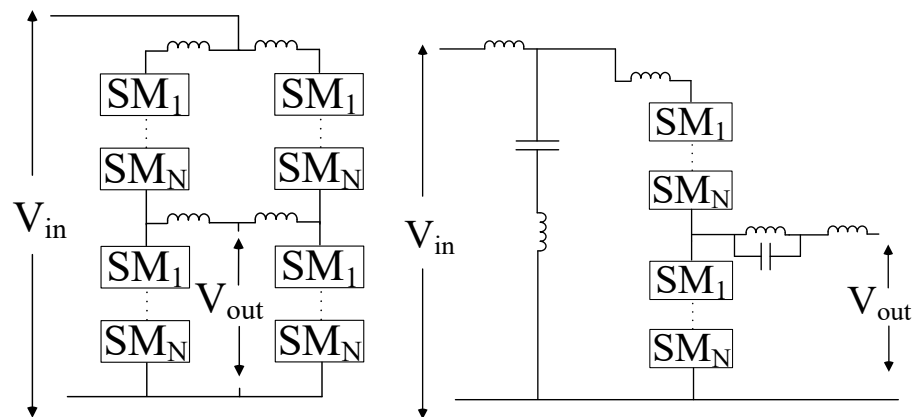

Figure 17. Push–pull and tuned filter MMDC.

#### 4.2. Smart Transformer

Smart transformers have been suggested as a method that can be used to control hybrid networks and to provide ancillary services. According to [156], a smart transformer, or a solid-state transformer (SST), is a collection of digitally controlled high-powered semiconductors that enable the network to be controlled. It can increase or decrease voltages, with the input and output of both AC and DC voltages being able to alter the frequency levels, improving the stability of the power supply [157]. Reference [80] claims that the high costs of the proposed STs are justified by these operation capabilities.

Liserre et al. in [158] provides a detailed overview on the possible role of the smart transformer and the key architectures and ancillary services it could provide. The SST essentially acts as the “heart of the system”, and its role is to interact with variable power supplies, to gather information on demand and priority loads, and to provide intelligent control of electric vehicles and other domestic loads. The ST could also interact with local generators to control the grid frequency and to decrease power injections from the DC side to avoid reverse power flow. The author of [159] displays MVDC-meshed hybrid grids that can be created with STs and BESS. The ST allows three levels of connection: MVDC, LVDC, and LVAC, and provides control systems for each converter, ensuring that the voltage stability is maintained on the voltage buses during the voltage sag operating mode. The control system compares the active power from the DG and injects the required power from the MVAC grid.

There are several possible ST implementations, such as SPEN, that with funding from OFGEM, have embarked on the LV Engine, a project that aims to aid in the uptake of low-carbon technologies based on DC [156], with one such technology being the smart transformer. As many loads, such as electric vehicles and heat pumps rely on DC, the LV Engine project aims to design a smart transformer that provides a LV DC supply to customers that will increase the transfer capacity of the network. According to SPEN, the ST will allow for optimum phase voltage regulation at low voltages, optimum substation-active power sharing, MV network voltage regulation (11 kV), the provision of a LVDC customer supply, a modular design, and scalability.

The Shenzhen MVDC distribution project [89] implemented a DC SST with multiple DAB cell modules. The smart transformers were connected at two points of the distribution system for load connection.

Despite the aforementioned promising application of SSTs, the high cost that is associated with most topologies has to be considered. Reference [158] predicts that SST will not be mass produced in the near future and that only a few grid nodes will have them installed.

#### 4.3. IGBT and MOSFETs

For different MVDC technologies, there will be varying uses of IGBTs and MOSFETs. Heat dissipation and switching losses are an issue with the ever-increasing power converter penetration; therefore, improvements in semiconductor materials will significantly affect the sector [160].

Silicon (Si) IGBTs dominate MMC converters for medium and high voltage applications, but wide bandgap semiconductor devices, e.g., the silicon carbide (SiC) MOSFET, would have superior performance, such as high-frequency capability and lower losses. However, SiC semiconductors are more expensive than their Si-based counterparts [138].

IGBTs and MOSFETs also have an important role to play in protection and are primarily used in DC solid-state circuit breakers (SSCBs) [84]. The advantages and disadvantages of IGBTs and MOSFETs are highlighted in Table 2.

**Table 2.** MOSFET and IGBT comparison for MVDC applications.

MOSFET (SiC)		IGBT	
Advantage	Disadvantage	Advantage	Disadvantage
Low switching loss	High conduction loss [161]	Low conduction loss	High switching loss
Higher switching frequencies	High cost [138]	Low cost	Low switching frequency required
Improved thermal properties [162]	Forward voltage degradation [163]	Can withstand high short circuit currents	Cannot block high reverse voltages
Higher voltage blocking [164]	Reliability issues	Low driving power [165]	Generally unidirectional
		Fast response [84]	

## 5. Protection

### 5.1. Overview

Protection in AC systems is very advanced, with IEEE standards having already been implemented for the grid, ship, and rail systems. However, there has been limited research that has been conducted on DC protection [166] and commercially available products. MVDC networks have no current zero-crossings and low DC impedances, [83] meaning that the fault current will be high. Dealing with short circuit currents is predicted to be a great difficulty in DC grids [84], and compared to AC systems, the protection in DC will be much more complex [79]. This is partly due to the fact that in AC systems, power flow is generally in one direction; however, due to bidirectional converters, a DC fault is often propagated to all of the interconnected converters in DC systems [134]. The increase in power electronics also adds to the system complexity in terms of protection. Power converters are more sensitive to overcurrents and over voltages that transformers are, and therefore, external protection is required [167].

Protection systems have the following requirements: sensitivity, selectivity, robustness, reliability, and speed [134]. Reliability is of vital importance for all networks, grid distribution, microgrids, rail, and onboard ship systems [14]; therefore, DC protection must ensure that DC grids are not frequently down due to common short circuit faults. The entire protection system must protect the DC system and prevent any faults from propagating into the connected AC systems.

### 5.2. System Protections

The key system protection components for developing DC systems will likely rely on DC circuit breakers, fuses, disconnecter switches, and surge arrestors. The DC circuit breaker (DCCB) requires the greatest development in terms of the necessary components. There are three key DCCB structures, i.e., mechanical CBs with active current injection, solid-state CBs (SSCBs), and hybrid CBs [79].

Mechanical DCCBs have low on-state resistance, but their opening speed is slow, and they require maintenance due to moving parts. They create an artificial zero-crossing point for the current that is flowing through the mechanical breakers by activating the LC resonance circuit [168].

SSCBs are defined by fast clearance times and less maintenance but higher conduction losses due to the semiconductor devices in the main current path. IGBTs are commonly used as the switches, and across the IGBT branch, a metal oxide varistor (MOV), which acts as a surge arrestor, is connected to absorb the discharged energy, as shown in Figure 18. Ultimately, the SSCB offers the fastest clearing time and the lowest fault current; however, it has much greater power losses than the other two topologies, as detailed experimentally in [79]. Continued development in semiconductor devices could lead to reduced SSCB power loss. Several papers have investigated improvements to the SSCB, such as [169], which implements an RC buffer branch due to its ability to clear faults

quickly and to resist very large currents. Reference [83] proposes an interlinked solid-state MVDC circuit breaker (ISSCB). The author of [157] presents a SSCB for the protection of BESS terminals from overcurrents. The SSCB comprises several IGBTs and diodes in series, increasing the cost and the risk of complication.

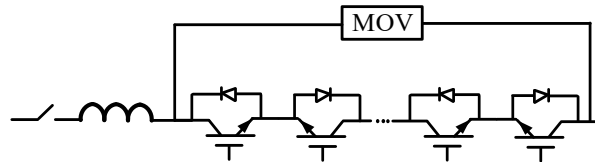

**Figure 18.** Solid-state DC circuit breaker.

The hybrid CBs that are illustrated in Figure 19 have the characteristics of both mechanical and SSCBs, achieving faster response times than mechanical CBs, and have the benefit of lower conduction losses than SSCBs [79]. These CBs do not achieve a clearing time that is as fast as or that a fault current that is as low as that of a solid-state CB. Furthermore, they are also large and require cooling systems [168]. Common topologies are compared in reference [170].

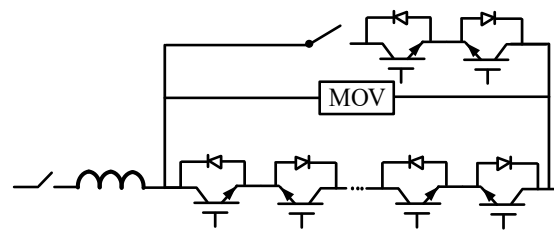

**Figure 19.** Hybrid DC circuit breaker.

Although DCCB technology is relatively new, there are several commercial examples. Reference [5] details the selection process for the DC circuit breaker for the Zhuhai project, where hybrid DCCBs are used. The mechanical switch in the main branch of the CB provided low on-state losses, high reliability, and low maintenance costs. The metal oxide surge arrester configuration branch would then limit over voltage.

In the SPEN Angle DC project, the DC circuit was installed with a manual disconnector with a grounding switch to enable the circuit to be isolated. Therefore, a single fault in one of the DC cables would be isolated from the circuit, with the rest of the circuit is still being in service [4].

### 5.3. Converter Protection

Converter fault isolation methods will also play a significant role in DC grid protection [114]. Fault currents need to be quickly interrupted to avoid damage to the switches. The author of [127] presents the issue of DC fault handling in MMCs, stating that after a DC fault, the freewheeling diode in the converter acts as an uncontrolled rectifier that prevents dc-fault isolation in a flexible DC system. HB MMCs cannot block DC fault currents nor can 2L-VSCs [134]. Several papers have recommended FB MMCs for DC grids due to their fault blocking capabilities [171,172]; however, other papers such as [127] suggest still utilising an HB-SM with a double thyristor in order to reduce investment and power loss. This would isolate AC/DC faults by generating symmetric fault points and short circuits, after which the DC fault current can decay. The authors of [126,171] suggest hybrid MMC configurations that utilise both HB and FB sub-modules, allowing for complete fault handling capability whilst also being cost effective.

#### 5.4. Control for Protection

Systems with DCCBs, FB MMC converter fault protection, and DC isolation switches could all be utilised for DC fault operation with a fast response; however, the costs are still significant in these developing sectors. Furthermore, even with the FB submodule MMCs that block faults, there are associated short-term black outs that occur in the DC network following the fault. Several papers have recommended various control systems to effectively utilise protection devices such as DCCBs whilst controlling the current and voltage, ensuring fault ride through. The author of [102] highlights issues with the ACCBs that are integrated in DC systems as well as with the DCCBs and MMCs in MTDC networks and proposes a control system that enables reduced numbers of DCCBs and that can respond during an MMC substation going offline. Reference [171] also proposes an integrated protection control for limiting current, fault detection, and fault clearance whilst maintaining the operation of healthy lines. In MTDC grids, it is important to maintain network reliability and to enable faults to be detected and cleared quickly.

Protection control systems can also be integrated into other protection technologies, such as DCCBs with current regulation, as detailed in [83]. The paper recommends a current flow controller to prevent post-fault conditions where a faulty DC line is disconnected and where overloading occurs.

### 6. Control of Converters for MVDC Systems

Control is an important aspect for MVDC networks. Several types of converter controllers can be implemented in the different converters, depending on the control objective, which can be focused on AC or DC network requirements.

#### 6.1. DC-AC Converter Control

Figure 20 shows the control for a grid following VSC with a traditional current controller that utilises vector control. This consists of the three-phase AC voltage from the converter and grid being translated with the Park transform to the synchronous dq reference frame, which effectively allows for DC control [173]. The grid to converter connection is modelled as the Thevenin equivalent circuit, and the LCL is filter between them. The resistance and inductance for the grid are  $R_n$  and  $L_n$ , and for the converter, they are  $R_c$  and  $L_c$ . The Park transform utilises a phase locked loop (PLL) to obtain the angle and angular velocity of the grid from the point of common coupling (PCC) and calculates the dq reference frame voltages and currents. The outer loop calculates the power from the measured currents and voltages and is able to obtain the reference currents from a power and voltage reference. The inner current loop then passes through the dq-measured currents and calculates the voltages  $V_{dq}$  and  $V_{dq}$  to be applied to the converter. This topology follows the grid, which measures the grid voltage angle in order to regulate the power output [174].



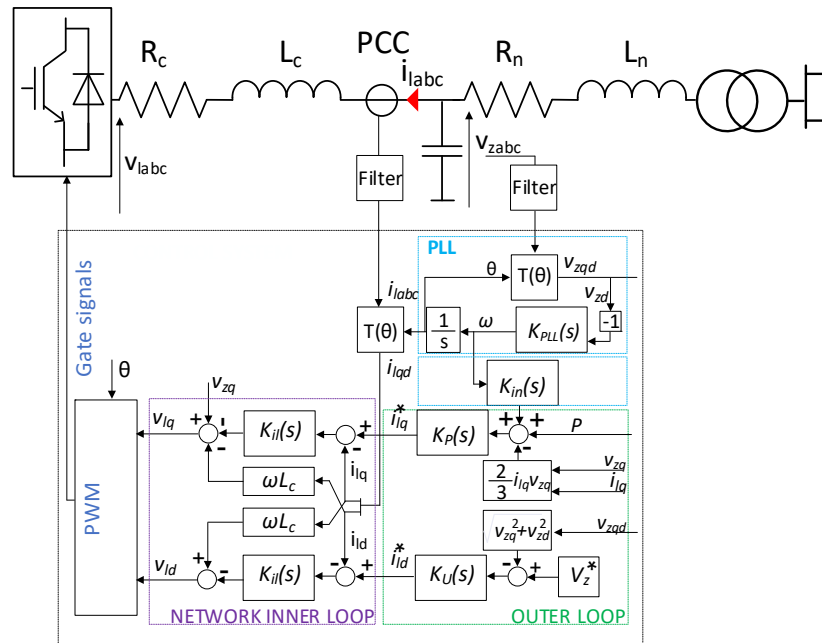

Figure 20. Traditional current control.

With increasing power converter penetration comes system stability issues. The traditional AC grid has large rotating turbines that provide inertia to the grid. With the reduction of synchronous generators and an increase in the number of power converters, the stability of the grid is threatened as it would be during a frequency disturbance, because with a low inertia system, the rate of change of frequency (RoCoF) is much higher, and the system can be more easily destabilized. Inertia can be related to the active power that is injected with the swing equation [175]:

$$P = J\Delta\omega \frac{d\Delta\omega}{dt} - D\Delta\omega \tag{1}$$

which, in turn, controls the rate of change of frequency. Where  $P$  is the stored power,  $J$  is the inertia constant,  $\omega$  is grid frequency, and  $D$  is the droop coefficient.

Inertia emulation and control have been researched for many years now in order to enable decoupled renewable energy sources to provide inertia to the AC grid, similar to synchronous generators. One method to combat low inertia is with the grid forming converter, the virtual synchronous machine (VSM), which is shown in Figure 21, which emulates inertia and the characteristics of the synchronous machine; a topology of an example VSM is given in [176]. Unlike the grid-following topology of Figure 20, there is no PLL to estimate the grid angle. Voltages and currents,  $V_{abc}$  and  $I_{abc}$ , at the PCC are fed to the peak calculator to obtain the peak and to calculate the measured power  $P_{meas}$ , which is attracted to the reference power. The voltage controller loop controls the voltage magnitude at the PCC, and the power loop PI controller acts as the swing equation and emulates the response of a synchronous generator [175].

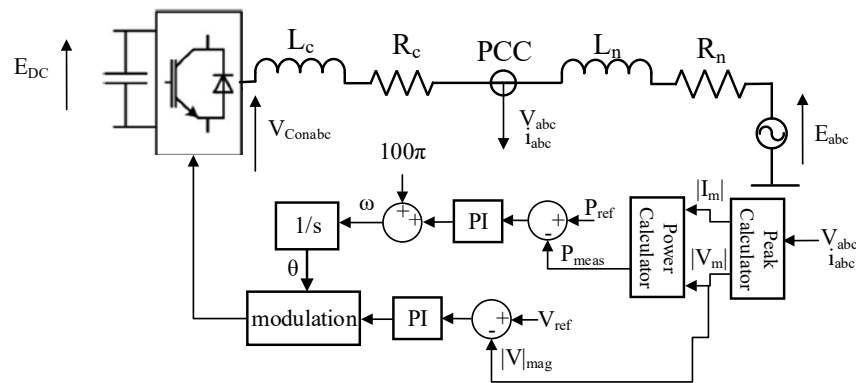

**Figure 21.** Virtual synchronous machine general control.

The traditional current controller can also be modified to implement inertia emulation by adding a branch proportional to the rate of change of frequency to the power reference, as detailed in [177]. VSC control between AC and DC systems will utilise such control methods and will continue to face inertial issues. Power injection and absorption to the DC grid must also be balanced.

The utilisation of VSCs in MVDC networks provides significant ancillary services for both the DC and AC interconnected grids. Aithal et al. in [160] proposes the control of an MVDC link, highlighting the benefits of each VSC connection having its own separate control system. References [20,22,24,79] and extensive literature agrees with [160] that the VSCs at each node provide flexible control and DC voltage balancing. The operating modes (all four of the P-Q plane quadrants) are all available to the network operator, with continuous control of the set points, all whilst fixing the DC link voltage. Castelo De Oliveira et al. in [178] experimentally tested the flexibility of AC–DC links and claimed that the main priority of DC operation is to provide the ancillary services that are required by the grid (as well as increasing power capacity). The paper concluded that the VSC controlled the DC link effectively and that it was capable of switching from power transmission to shunt FACTS.

## 6.2. DC Control

The primary concern of DC control is the ability to maintain a stable DC voltage at the DC bus and in any submodules, arms, and branches in a converter if they are present. In MTDC systems, DC voltage control is achieved with master–slave control, voltage margin control [179], and droop control [180], as shown in Figure 22. Traditionally, the “master–slave” control structure has been adopted [181], which is a centralised DC voltage control method. The master controller operates in constant DC voltage mode and the other controllers, the “slave” terminals, operate under constant power mode. This method can produce highly accurate operation with the master converter, ensuring that the DC voltage is kept at the reference voltage [182].

Voltage margin control extends the master–slave technique; however, it allows wherein VSC becomes the DC voltage controller [183]. The VSC operates within the P- $V_{dc}$  characteristic.

However, centralised DC control has several drawbacks, such as poor transients, with just one controller controlling DC voltage level, and it also relies on fast communication [182]. Furthermore, for both the master–slave and voltage margin controls, if there is an outage in the DC voltage controller, the voltage of the whole system becomes unstable; hence, droop control is preferable.

Hence, distributed DC voltage control has since been suggested to reduce dependence on fast communication [180]. Each converter has a DC voltage droop controller and one controller controlling the AC active power. Droop control offers better stability during

VSC outages on the system compared to voltage margin control. The DC bus voltage is maintained across the DC link, which can be achieved using Equations (2) and (3).

$$P_{DCrec}^* = k_{droop}(E_{rec}^* - E_{DC}) \tag{2}$$

$$P_{DCinv}^* = k_{droop}(E_{DC} - E_{rec}^*) \tag{3}$$

where  $P_{DCrec}^*$  is the reference power,  $k_{droop}$  is the droop gain,  $E_{inv}^*$  is inverter voltage offset, and  $E_{rec}^*$  is the rectifier offset [184].

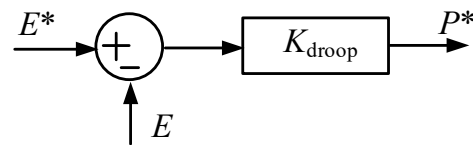

Figure 22. Voltage droop control.

### 6.3. Network Level Control

Traditional AC distribution grids conventionally have power flow in one direction, with the high levels moving down to the AC distribution grid. An AC/DC hybrid grid could enable the AC distribution grid to be interlinked with a DC distribution grid at varying levels, offering flexibility with decentralised control, easing the integration of distributed renewables.

Two methods of communication in the AC/DC hybrid grid could exist: the conventional grid communication network and non-utility-based networks such as the IoT, as shown in Figure 23 [185]. In a traditional communication structure, the distribution operator (DO) was entirely in control of the distribution reliability and communication. Increasingly, distribution grids are developing to be able to contain distributed renewables, which might not be controlled directly by the DO but rather by the energy services organisation (ESO). This communication is through the internet and communicates with the DO and an independent system operator (ISO).

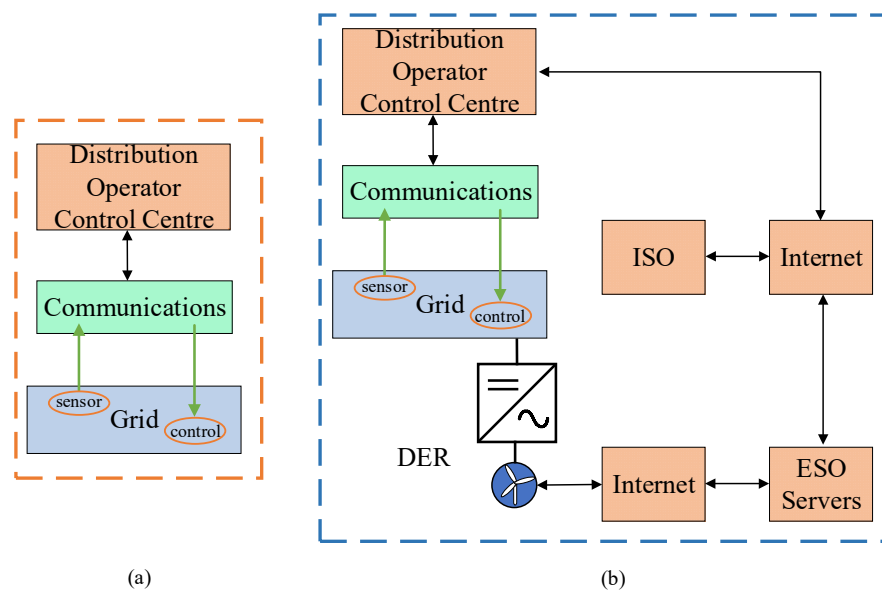

Figure 23. (a) Traditional control communications compared to (b) AC/DC hybrid grid communications.

However, these AC/DC systems, with their increased flexibility and power flow complexity, have new demands and dynamic issues [186]. MVDC distribution grids also tend to have an increased geographical range with increased DERs and load and power fluctuations that significantly affect system operation and control [187]. MVDC distribution is also characterised by high converter penetration with extensive voltage and power control. Fast and reliable communication is required for this extensive controllability and requires the use of units such as phase measurement units (PMUs) and synchronous DC Measurement Units (SynDCs) [188]. A central DC redispatch to perform recalculations during a DC or AC contingency is essential in multiterminal grids. When a power converter disconnects, the redispatch restores power exchange and redirects power flow from one area to another [184].

## 7. Conclusions

This paper has presented a complete review of the applications of MVDC systems along with the possible benefits that are offered by the adaption of this technology. System topologies, hardware, protection, and control were discussed.

The four main MVDC applications that were reviewed in this paper were shipboard systems, rail, offshore wind collection, and distribution grids. For rail systems, the lower end of MVDC technology is already in use for tram, metro, and subway systems; however, long-distance travel with MVDC is being suggested at higher voltages of around 10 kV, and the recommended voltage for high-speed railways is 20–30 kV.

For shipboard IPSs, MVDC power systems are emerging as an alternative to AC systems with heavy transformers. The industry has had IPSs available for several decades; however, the system was traditionally AC-based. Further to this, to improve efficiency, fuel economy, and power quality, all-electric ships are emerging in the industry [42], as developments in power electronics, namely MMCs, in shipboard systems offer voltage and power scalability [10,132] and FB sub-modules; they also have good fault blocking capability [134]. MVDC systems offer more flexibility in the on-board network structure compared to traditional AC systems, which are often radially distributed. Using an MVDC grid could improve system controllability and could improve security and reliability [33].

Distribution grids are beginning to introduce MVDC links and DC grids. MVDC interties will enable the use of SOPs to provide ancillary services to the grid [25]. There are several examples of DC links [87,88], and small DC distribution networks have been developed in southeastern China [89,90]. Multiterminal DC grids will likely develop in commercial industries, grids, and interties with HVDC systems [26]. The technology that is required for MVDC distribution grids is available, as MVDC systems have the flexibility of utilising 2L and 3L VSCs as well as MMCs. The 2L and 3L converters could be utilised at voltages of up to around  $\pm 10$  kV DC [126], and MMCs could provide the required step that needs to be taken before for higher voltages can be used. For DC–DC connections, multilevel DAB converters and MMDCs are suggested in the literature. The MMDC has higher efficiency and reliability but no galvanic isolation. For projects [4,5,90,92], the voltage can range from 10 kV to 27 kV. This will likely be the mean distribution range, but there may be an extension of up to 50 kV or to even 100 kV for distributed renewable connection.

However, offshore wind collection is still being developed, and there are currently no active MVDC collection systems. The lower weight of MVDC collection substations compared to AC collection or HVDC substations could significantly reduce the capital cost of the system [68]. MMC technology could achieve the high step-up ratios that are required and has good short-term reliability with active redundancy, but the long-term survival of the technology in offshore conditions is still under investigation [93].

The protection mechanisms that are implemented in DC grids will have to ensure that faults are not propagated from the DC to the AC side and vice versa. Three categories

of DC circuit breakers are continually being developed: mechanical, solid state, and hybrid. The SSCBs are the fastest; however, they have significant losses, so hybrid DCCBs have become the most common. The fault propagation from one AC system through a DC link has been highlighted as a concern in the literature [189]. However, it has been suggested that existing AC protection systems can be updated for MVDC protection [190]. Damping the oscillations between multiterminal DC grids with AC connections is also being investigated in the literature [189,191].

MVDC systems offer several benefits for the applications presented in this paper, from flexibility, controllability, and reliability to increased capacity. Continued developments in DCCB technology are still required to improve costs and power losses in SSCBs. However, the technology is available and is being utilised for rail, shipboard, and distribution systems, and MVDC systems could begin to take prevalence on the electrical stage.

**Author Contributions:** Conceptualization, A.E.-À.; investigation, S.C., V.T.; data curation, S.C., V.T., R.L., G.W.; writing-original draft preparation, S.C.; writing-review and editing, S.C., V.T., A.E.-À., R.L., G.W.; supervision, A.E.-À., R.L. All authors have read and agreed to the published version of the manuscript.

**Funding:** This research received no external funding.

**Institutional Review Board Statement:** Not applicable.

**Informed Consent Statement:** Not applicable.

**Data Availability Statement:** Not applicable.

**Conflicts of Interest:** The authors declare no conflict of interest.

## References

1. Kumar, D.; Zare, F.; Ghosh, A. DC Microgrid Technology: System Architectures, AC Grid Interfaces, Grounding Schemes, Power Quality, Communication Networks, Applications, and Standardizations Aspects. *IEEE Access* **2017**, *5*, 12230–12256, doi:10.1109/ACCESS.2017.2705914.
2. Kong, X.; Yan, Z.; Guo, R.; Xu, X.; Fang, C. Three-Stage Distributed State Estimation for AC-DC Hybrid Distribution Network under Mixed Measurement Environment. *IEEE Access* **2018**, *6*, 39027–39036, doi:10.1109/ACCESS.2018.2853664.
3. Ryndzionek, R.; Sienkiewicz, Ł. Evolution of the HVDC link connecting offshore wind farms to onshore power systems. *Energies* **2020**, *13*, 1914, doi:10.3390/en13081914.
4. Yu, J.; Smith, K.; Urizarbarrena, M.; Macleod, N.; Moon, A. Initial Designs for Angle-DC Project: Challenges Converting Existing Ac Cable And Overhead Line To Dc Operation. In Proceedings of the CIRED 2017, Glasgow, UK, 12–15 June 2017; Volume 2017, pp. 12–15.
5. Qu, L.; Yu, Z.; Song, Q.; Yuan, Z.; Zhao, B.; Yao, D.; Chen, J.; Liu, Y.; Zeng, R. Planning and analysis of the demonstration project of the MVDC distribution network in Zhuhai. *Front. Energy* **2019**, *13*, 120–130, doi:10.1007/s11708-018-0599-2.
6. Brenna, M.; Foadelli, F.; Zaninelli, D. DC Railway Electrification Systems. In *Electrical Railway Transportation Systems*; Wiley-IEEE Press: Hoboken, NJ, USA, 2018; pp. 99–175.
7. Verdicchio, A.; Ladoux, P.; Caron, H.; Sanchez, S. Future DC Railway Electrification System—Go for 9 kV. In Proceedings of the 2018 IEEE International Conference on Electrical Systems for Aircraft, Railway, Ship Propulsion and Road Vehicles and International Transportation Electrification Conference, ESARS-ITEC 2018, Nottingham, UK, 7–9 November 2018; IEEE: Piscataway, NJ, USA, 2019.
8. Verdicchio, A.; Ladoux, P.; Caron, H.; Courtois, C. New Medium-Voltage DC Railway Electrification System. *IEEE Trans. Transp. Electrif.* **2018**, *4*, 591–604, doi:10.1109/TTE.2018.2826780.
9. Jayasinghe, S.G.; Meegahapola, L.; Fernando, N.; Jin, Z.; Guerrero, J.M. Review of ship microgrids: System architectures, storage technologies and power quality aspects. *Inventions* **2017**, *2*, 4, doi:10.3390/inventions2010004.
10. Soman, R.; Steurer, M.M.; Toshon, T.A.; Faruque, M.O.; Cuzner, R.M. Size and Weight Computation of MVDC Power Equipment in Architectures Developed Using the Smart Ship Systems Design Environment. *IEEE J. Emerg. Sel. Top. Power Electron.* **2017**, *5*, 40–50, doi:10.1109/JESTPE.2016.2625030.
11. Networks, S.E. *2015 ANGLE-DC Electricity Network Innovation Competition*; Ofgem: London, UK, 2015; pp. 1–101.
12. Zhang, L.; Tang, W.; Liang, J.; Li, G.; Cai, Y.; Yan, T. A Medium Voltage Hybrid AC/DC Distribution Network And Its Economic Evaluation. In Proceedings of the 12th IET International Conference on AC and DC Power Transmission (ACDC 2016), Beijing, China, 28–29 May 2016.

13. Faddel, S.; Saad, A.A.; Mohammed, O. Decentralized energy management of hybrid energy storage on MVDC shipboard power system. In Proceedings of the 2018 IEEE Industry Applications Society Annual Meeting (IAS), 23–27 September 2018, doi:10.1109/IAS.2018.8544604.
14. Li, H.; Li, W.; Luo, M.; Monti, A.; Ponci, F. Design of smart MVDC power grid protection. *IEEE Trans. Instrum. Meas.* **2011**, *60*, 3035–3046, doi:10.1109/TIM.2011.2158152.
15. Wang, L.; Zhang, G.; Shen, M.; Quan, H.; Liu, Z. A novel traction supply system for urban rail transportation with bidirectional power flow and based on PWM rectifier. In Proceedings of the 2009 International Conference on Energy and Environment Technology, Guilin, China, 16–18 October 2009; Volume 2, pp. 40–43, doi:10.1109/ICEET.2009.246.
16. Ferencz, I.; Petreus, D.; Tricoli, P. Converter Topologies for MVDC Traction Transformers. In Proceedings of the 2020 IEEE 26th International Symposium for Design and Technology in Electronic Packaging, SIITME 2020, Piscataway, NJ, USA, 21–24 October 2020; pp. 362–367.
17. Maza-Ortega, J.M.; Acha, E.; García, S.; Gómez-Expósito, A. Overview of power electronics technology and applications in power generation transmission and distribution. *J. Mod. Power Syst. Clean Energy* **2017**, *5*, 499–514, doi:10.1007/s40565-017-0308-x.
18. Gao, S.; Liu, S.; Liu, Y.; Zhao, X.; Song, T.E. Flexible and Economic Dispatching of AC/DC Distribution Networks Considering Uncertainty of Wind Power. *IEEE Access* **2019**, *7*, 100051–100065, doi:10.1109/access.2019.2930248.
19. Kong, D.; Liu, C.; Ying, H.; Pei, Z.; Li, J.; Zhang, H. Operating Modes Analysis and Control Strategy of Single-Stage Isolated Modular Multilevel Converter (I-MMC) for Medium Voltage AC/DC Grid. In Proceedings of the IECON 2019—45th Annual Conference of the IEEE Industrial Electronics Society, Lisbon, Portugal, 14–17 October 2019; pp. 5674–5679, doi:10.1109/IECON.2019.8927196.
20. Bathurst, G.; Hwang, G.; Tejwani, L. MVDC—the new technology for distribution networks. *IET Semin. Dig.* **2015**, *2015*, 1–5, doi:10.1049/cp.2015.0037.
21. Salehi, V.; Mirafzal, B.; Mohammed, O. Pulse-load effects on ship power system stability. In Proceedings of the IECON 2010—36th Annual Conference on IEEE Industrial Electronics Society, Glendale, AZ, USA, 7–10 November 2010; IEEE: Piscataway, NJ, USA, 2010; pp. 3353–3358.
22. Qi, C.; Wang, K.; Fu, Y.; Li, G.; Han, B.; Huang, R.; Pu, T. A decentralized optimal operation of AC/DC hybrid distribution grids. *IEEE Trans. Smart Grid* **2018**, *9*, 6095–6105, doi:10.1109/TSG.2017.2703582.
23. Zhou, Q.; Yuan, D. Prediction on future DC power system. In Proceedings of the 2009 IEEE 6th International Power Electronics and Motion Control Conference, Wuhan, China, 17–20 May 2009; pp. 1192–1195, doi:10.1109/IPEMC.2009.5157564.
24. Cao, W.; Wu, J.; Jenkins, N.; Wang, C.; Green, T. Operating principle of Soft Open Points for electrical distribution network operation. *Appl. Energy* **2016**, *164*, 245–257, doi:10.1016/j.apenergy.2015.12.005.
25. Bloemink, M. Distribution-Level Power Electronics: Soft Open-Points. Ph.D. Thesis, Imperial College London: London, UK, 2013.
26. Simiyu, P.; Xin, A.; Wang, K.; Adwek, G.; Salman, S. Multiterminal medium voltage DC distribution network hierarchical control. *Electronics* **2020**, *9*, 506, doi:10.3390/electronics9030506.
27. Parastar, A.; Hasanvand, H.; Eshagi, M.; Zamani, M.R. Multilevel Step-Up DC/DC Converter for MVDC Applications. In Proceedings of the 30th Power System Conference, Tehran, Iran, 23–25 November 2015.
28. Cahyagi, D. Study of Shipboard Power Distribution System: Review on an Application of AC Zonal Distribution. *IPTEK J. Eng.* **2018**, *4*, 2337–8530, doi:10.12962/joe.v4i1.3734.
29. Rickover, H.G.; Ross, P.N. Fault Protection on Shipboard A-C Power-Distribution Systems. *Trans. Am. Inst. Electr. Eng.* **1944**, *63*, 1109–1120, doi:10.1109/T-AIEE.1944.5058854.
30. Dale, S.J. Ship power system testing and simulation. In Proceedings of the IEEE Electric Ship Technologies Symposium, Philadelphia, PA, USA, 27 July 2005, doi:10.1109/ESTS.2005.1524675.
31. Kumar, D.; Zare, F. A Comprehensive Review of Maritime Microgrids: System Architectures, Energy Efficiency, Power Quality, and Regulations. *IEEE Access* **2019**, *7*, 67249–67277, doi:10.1109/ACCESS.2019.2917082.
32. Schuddebeurs, J.D.; Norman, P.J.; Booth, C.D.; Burt, G.M.; McDonald, J.R. Emerging Research Issues Regarding Integrated-Full-Electric-Propulsion. In Proceedings of the 41st International Universities Power Engineering Conference Newcastle, UK, 6–8 September 2006; pp. 669–673.
33. Cupelli, M.; Ponci, F.; Sulligoi, G.; Vicenzutti, A.; Edrington, C.S.; El-Mezyani, T.; Monti, A. Power Flow Control and Network Stability in an All-Electric Ship. *Proc. IEEE* **2015**, *103*, 2355–2380, doi:10.1109/JPROC.2015.2496789.
34. Jin, B.Z.; Sulligoi, G.; Cuzner, R.; Meng, L.; Vasquez, J.C.; Guerrero, J.M. Next-Generation Shipboard DC Power System. *IEEE Electr. Mag.* **2016**, *4*, 45–57.
35. Balsamo, F.; Lauria, D.; Mottola, F. Design and Control of Coupled Inductor DC–DC Converters for MVDC Ship Power Systems. *Energies* **2019**, *12*, 751, doi:10.3390/en12040751.
36. Mariscotti, A. Power quality phenomena, standards, and proposed metrics for dc grids. *Energies* **2021**, *14*, 6453, doi:10.3390/en14206453.
37. Castellan, S.; Menis, R.; Tassarolo, A.; Luise, F.; Mazzuca, T. A review of power electronics equipment for all-electric ship MVDC power systems. *Electr. Power Energy Syst.* **2018**, *96*, 306–323, doi:10.1016/j.ijepes.2017.09.040.

38. Siemens Gamesa Queen Elizabeth Class (QEC) Aircraft Carrier. Available online: [https://www.gpowerconversion.com/sites/default/files/MARINE\\_GEA20337—Queen Elizabeth—Case Study.pdf](https://www.gpowerconversion.com/sites/default/files/MARINE_GEA20337—Queen Elizabeth—Case Study.pdf) (accessed on 7 December 2021).
39. Andrus, M.; Ravindra, H.; Hauer, J.; Steurer, M.; Bosworth, M.; Soman, R. PHIL implementation of a MVDC fault management test bed for ship power systems based on megawatt-scale modular multilevel converters. In Proceedings of the 2015 IEEE Electric Ship Technologies Symposium (ESTS), Old Town Alexandria, VA, USA, 24–25 June 2015; pp. 337–342, doi:10.1109/ESTS.2015.7157915.
40. Skjong, E.; Rødskar, E.; Molinas, M.; Johansen, T.A.; Cunningham, J. The Marine Vessel's Electrical Power System: From its Birth to Present Day. *Proc. IEEE* **2015**, *103*, 2410–2424, doi:10.1109/JPROC.2015.2496722.
41. Kongsberg Autonomous Ship Project, Key Facts about Yara Birkeland. Available online: <https://www.kongsberg.com/maritime/support/themes/autonomous-ship-project-key-facts-about-yara-birkeland/> (accessed on 22 April 2021).
42. Ferry, E.; Kortsari, A.; Mitropoulos, L.; Heinemann, T.; Mikkelsen, H.H. Evaluation Report of the E-Ferry; E-Ferry, 2020. Available online: [http://www.conf.eferry.eu/InfoPackage/eFerry\\_Information\\_Package.pdf](http://www.conf.eferry.eu/InfoPackage/eFerry_Information_Package.pdf) (accessed on 7 December 2021).
43. European Maritime Safety Agency; Helgesen, H.; Henningsgård, S.; Aarseth Langli, A. Electrical Energy Storage for Ships; European Maritime Safety Agency, Norway, 2020. Available online: <http://www.emsa.europa.eu/publications/item/3895-study-on-electrical-energy-storage-for-ships.html> (accessed on 7 December 2021).
44. Sharifabadi, K.; Harnefors, L.; Nee, H.P.; Norrga, S.; Teodorescu, R. *Design, Control and Application of Modular Multilevel Converters for HVDC Transmission Systems*; Wiley-IEEE Press: Hoboken, NJ, USA, 2016; ISBN 9781118851555.
45. Corvus Energy. *CASE STUDY: Norled AS, MF Ampere, Ferry*; Corvus Energy: Richmond, BC, Canada, 2015.
46. Gómez-Expósito, A.; Mauricio, J.M.; Maza-Ortega, J.M. VSC-Based MVDC Railway Electrification System. *IEEE Trans. Power Deliv.* **2014**, *29*, 422–431.
47. Nunno, R. Electrification of U.S. Railways: Pie in the Sky, or Realistic Goal? Available online: <https://www.eesi.org/articles/view/electrification-of-u.s.-railways-pie-in-the-sky-or-realistic-goal> (accessed on 4 May 2021).
48. Fei, Z.; Konefal, T.; Armstrong, R. AC railway electrification systems—An EMC perspective. *IEEE Electromagn. Compat. Mag.* **2019**, *8*, 62–69, doi:10.1109/MEMC.2019.8985603.
49. Mwambeleko, J.J.; Kulworawanichpong, T. Battery and accelerating-catenary hybrid system for light rail vehicles and trams. In Proceedings of the 2017 International Electrical Engineering Congress (iEECON), Pattaya, Thailand, 8–10 March 2017, doi:10.1109/IEECON.2017.8075778.
50. Ratniyomchai, T.; Hillmanssen, S.; Tricoli, P. Recent developments and applications of energy storage devices in electrified railways. *IET Electr. Syst. Transp.* **2014**, *4*, 9–20, doi:10.1049/iet-est.2013.0031.
51. Hu, J.; Liu, W.; Yang, J. Application of power electronic devices in rail transportation traction system. In Proceedings of the 2015 IEEE 27th International Symposium on Power Semiconductor Devices & IC's (ISPSD), Hong Kong, China, 10–14 May 2015, doi:10.1109/ISPSD.2015.7123376.
52. Abrahamsson, L.; Schütte, T.; Östlund, S. Use of converters for feeding of AC railways for all frequencies. *Energy Sustain. Dev.* **2012**, *16*, 368–378, doi:10.1016/j.esd.2012.05.003.
53. Barinov, I.A.; Melnichenko, O.V. Power IGBTs application in AC-wire DC-motor locomotive thyristor-based power circuit for regenerative brake energy efficiency increase. 2019 International Conference on Industrial Engineering, Applications and Manufacturing (ICIEAM), Sochi, Russia, 25–29 March 2019, doi:10.1109/ICIEAM.2019.8742933.
54. Caron, H.; Réseau, C.C.S. New Medium Voltage DC Railway Electrification System. Available online: [https://uic.org/events/IMG/pdf/09\\_sncf\\_caron\\_mvdc\\_uic\\_workshop.pdf](https://uic.org/events/IMG/pdf/09_sncf_caron_mvdc_uic_workshop.pdf) (accessed on 7 December 2021)
55. Tobing, T.L.; Rachmilda, T.D.; Hindersah, H.; Rizqiawan, A.; Haroen, Y. Rectifier substation optimum position on DC traction systems. In Proceedings of the 4th International Conference on Electric Vehicular Technology, ICEVT 2017, Bali, Indonesia 2–5 October 2017, pp. 134–138.
56. Pereira, F.H.; Pires, C.L.; Nabeta, S.I. Optimal placement of rectifier substations on DC traction systems. *IET Electr. Syst. Transp.* **2014**, *4*, 62–69, doi:10.1049/iet-est.2010.0063.
57. Ogura, K.; Nishimura, K.; Oku, Y. A Bidirectional DC-DC Converter for Battery Electric Light Rail Vehicle and Its Test Run Results. In Proceedings of the 2019 IEEE 13th International Conference on Power Electronics and Drive Systems (PEDS), Toulouse, France, 9–12 July 2019, doi:10.1109/PEDS44367.2019.8998957.
58. Crotti, G.; Femine, A.D.; Gallo, D.; Giordano, D.; Landi, C.; Luiso, M.; Mariscotti, A.; Roccato, P.E. Pantograph-To-OHL Arc: Conducted Effects in DC Railway Supply System. *IEEE Trans. Instrum. Meas.* **2019**, *68*, 3861–3870, doi:10.1109/TIM.2019.2902805.
59. Midya, S.; Bormann, D.; Schütte, T.; Thottappillil, R. Pantograph arcing in electrified railways—Mechanism and influence of various parameters—Part I: With DC traction power supply. *IEEE Trans. Power Deliv.* **2009**, *24*, 1931–1939, doi:10.1109/TPWRD.2009.2021035.
60. Seferi, Y.; Blair, S.M.; Mester, C.; Stewart, B.G. A Novel Arc Detection Method for DC Railway Systems. *Energies* **2021**, *14*, 444, doi:10.3390/en14020444.
61. Boler, O.; Ibrahim, A.; Ali, A.A.; Granger, M.G.; Abdelgaber, H.; Sozer, Y.; De Abreu-Garcia, J.A. A Novel High Frequency Impedance Analysis Method to Protect DC Electrical Railway Systems. *IEEE Trans. Ind. Appl.* **2020**, *56*, 669–677, doi:10.1109/TIA.2019.2955415.
62. DNV GL. *66 kV Systems for Offshore Wind Farms*; DNV GL Energy: Arnhem, The Netherlands, 2015.

63. Lundberg, S. *Performance Comparison of Wind Park Configurations*; Chalmers University of Technology: Gothenburg, Sweden, 2003.
64. Max, L.; Lundberg, S. System efficiency of a DC/DC converter-based wind farm. *Wind Energy* **2008**, *11*, 109–120, doi:10.1002/we.259.
65. Parker, M.A.; Anaya-Lara, O. Cost and losses associated with offshore wind farm collection networks which centralise the turbine power electronic converters. *IET Renew. Power Gener.* **2013**, *7*, 390–400, doi:10.1049/iet-rpg.2012.0262.
66. De Prada Gil, M.; Domínguez-García, J.L.; Díaz-González, F.; Aragués-Peñalba, M.; Gomis-Bellmunt, O. Feasibility analysis of offshore wind power plants with DC collection grid. *Renew. Energy* **2015**, *78*, 467–477, doi:10.1016/j.renene.2015.01.042.
67. Pape, M.; Kazerani, M. An Offshore Wind Farm with DC Collection System Featuring Differential Power Processing. *IEEE Trans. Energy Convers.* **2020**, *35*, 222–236, doi:10.1109/TEC.2019.2951331.
68. Pan, J.; Bala, S.; Callavik, M.; Sandeberg, P. Platformless DC collection and transmission for offshore wind. *IET Semin. Dig.* **2015**, *2015*, 1–6, doi:10.1049/cp.2015.0075.
69. 4C Global Offshore Renewable Map. Available online: <https://map.4c offshore.com/offshorewind/> (accessed on 29 November 2021).
70. Meyer, C.; Höing, M.; Peterson, A.; De Doncker, R.W. Control and design of DC grids for offshore wind farms. *IEEE Trans. Ind. Appl.* **2007**, *43*, 1475–1482, doi:10.1109/TIA.2007.908182.
71. Barrenetxea, M.; Baraia, I.; Larrazabal, I.; Zubimendi, I. Design of a novel modular energy conversion scheme for DC offshore wind farms. In Proceedings of the IEEE EUROCON 2015—International Conference on Computer as a Tool (EUROCON), Salamanca, Spain, 8–11 September 2015, doi:10.1109/EUROCON.2015.7313701.
72. Holtmark, N.; Bahirat, H.J.; Molinas, M.; Mork, B.A.; Høidalen, H.K. An All-DC offshore wind farm with series-connected turbines: An alternative to the classical parallel AC model? *IEEE Trans. Ind. Electron.* **2013**, *60*, 2420–2428, doi:10.1109/TIE.2012.2232255.
73. Chuangpishit, S.; Tabesh, A.; Moradi-Sharbabk, Z.; Saeedifard, M. Topology design for collector systems of offshore wind farms with pure DC power systems. *IEEE Trans. Ind. Electron.* **2014**, *61*, 320–328, doi:10.1109/TIE.2013.2245619.
74. Bahirat, H.J.; Mork, B.A. Operation of DC Series-Parallel Connected Offshore Wind Farm. *IEEE Trans. Sustain. Energy* **2019**, *10*, 596–603, doi:10.1109/TSTE.2018.2839712.
75. Abeynayake, G.; Li, G.; Liang, J.; Cutulus, N.A. A Review on MVdc Collection Systems for High-Power Offshore Wind Farms. In Proceedings of the 2019 14th Conference on Industrial and Information Systems (ICIIS), Kandy, Sri Lanka, 18–20 December 2019; pp. 407–412, doi:10.1109/ICIIS47346.2019.9063352.
76. Rong, F.; Wu, G.; Li, X.; Huang, S.; Zhou, B. ALL-DC Offshore Wind Farm with Series-Connected Wind Turbines to Overcome Unequal Wind Speeds. *IEEE Trans. Power Electron.* **2019**, *34*, 1370–1381, doi:10.1109/TPEL.2018.2834965.
77. Zhang, L.; Liang, J.; Tang, W.; Li, G.; Cai, Y.; Sheng, W. Converting AC distribution lines to DC to increase transfer capacities and DG penetration. *IEEE Trans. Smart Grid* **2019**, *10*, 1477–1487, doi:10.1109/TSG.2017.2768392.
78. Working Group C6.31, CIGRE Medium Voltage Direct Current (MVDC) Grid Feasibility Study. ELECTRA CIGRE’s Digital Magazine April 2020, No. 309, pp. 1–5. Available online: <https://electra.cigre.org/309-april-2020/technical-brochures/medium-voltage-direct-current-mvdc-grid-feasibility-study.html> (accessed on 7 December 2021).
79. Giannakis, A.; Pefitsis, D. MVDC Distribution Grids and Potential Applications: Future Trends and Protection Challenges. In Proceedings of the 2018 20th European Conference on Power Electronics and Applications (EPE’18 ECCE Europe), Riga, Latvia, 17–21 September 2018; pp. 1–9.
80. Hrishikesan, V.M.; Das, D.; Kumar, C.; Gooi, H.B.; Mekhilef, S.; Guo, X. Increasing Voltage Support Using Smart Power Converter Based Energy Storage System and Load Control. *IEEE Trans. Ind. Electron.* **2020**, *68*, 12364–12374, doi:10.1109/TIE.2020.3042165.
81. Siemens MVDC Plus. *Managing the Future Grid*; Siemens: Munich, Germany 2021. <https://assets.siemens-energy.com/siemens/assets/api/uuid:d1bf00ec-b71f-4dcf-9401-7e08d2b508db/mvdc-plus-intro-final.pdf> (accessed 7 December 2021)
82. Stieneker, M.; Doncker, R.W. De Medium-voltage DC distribution grids in urban areas. In Proceedings of the 2016 IEEE 7th International Symposium on Power Electronics for Distributed Generation Systems (PEDG), Vancouver, BC, Canada, 27–30 June 2016; pp. 1–7.
83. Wang, S.; Ming, W.; Liang, J. Interlinked Solid-state MVDC Circuit Breaker with Current Regulation Capability. In Proceedings of the IECON 2019—45th Annual Conference of the IEEE Industrial Electronics Society, Lisbon, Portugal, 14–17 October 2019; pp. 5668–5673, doi:10.1109/IECON.2019.8927420.
84. Bayati, N.; Hajizadeh, A.; Soltani, M. Protection in DC microgrids: A comparative review. *IET Smart Grid* **2018**, *1*, 66–75, doi:10.1049/iet-stg.2018.0035.
85. Park, J. Do Ground fault detection and location for ungrounded DC traction power systems. *IEEE Trans. Veh. Technol.* **2015**, *64*, 5667–5676, doi:10.1109/TVT.2015.2388785.
86. Reed, G.F.; Grainger, B.M.; Sparacino, A.R.; Mao, Z.H. Ship to grid: Medium-voltage dc concepts in theory and practice. *IEEE Power Energy Mag.* **2012**, *10*, 70–79, doi:10.1109/MPE.2012.2212613.
87. Joseph, T.; Liang, J.; Li, G.; Moon, A.; Smith, K.; Yu, J. Dynamic Control of MVDC Link Embedded in Distribution Network: Case Study on ANGLE-DC. In Proceedings of the IEEE Conference on Energy Internet and Energy System Integration, Beijing, China, 26–28 November 2017; pp. 1–6.



88. UK Power Networks. Yu, J.; Cameron, I. *Active Response to Distribution Network Constraints*; Ofgem: London, UK, 2018. <https://innovation.ukpowernetworks.co.uk/wp-content/uploads/2018/12/Active-Response-FSP.pdf> (accessed 7 December 2021).
89. Liu, G.; Zhao, Y.; Yuan, Z.; Zhao, B.; Yu, Z.; Si, Z.; Sun, G.; Xu, X.; Han, Y.; He, Q.; et al. Study on Demonstration Project Technical Scheme of VSC-DC Distribution System in Shenzhen. *South. Power Syst. Technol.* **2016**, *10*, 1–7.
90. Su, L.; Zhu, P.; Yan, A.; Ma, Y.; He, M.; Mei, J.; Wang, B.; Fan, G. Design Scheme and Simulation Verification of Suzhou Medium Voltage DC Distribution Project. *Electr. Power* **2021**, *54*, 78–88.
91. Hunter, L.; Booth, C.; Ferre, A.J.; Finney, S. MVDC for enhanced utility scale distribution power delivery and control. In Proceedings of the 2017 52nd International Universities Power Engineering Conference, UPEC 2017, Heraklion, Greece, 28–31 August 2017; pp. 1–6.
92. Hardman, D. *FPL Development and Improvement Report*; Western Power Distribution: Bristol, UK, 2019.
93. Abeynayake, G.; Li, G.; Joseph, T.; Liang, J. Reliability and Cost-oriented Analysis, Comparison and Selection of Multi-level MVdc Converters. *IEEE Trans. Power Deliv.* **2021**, *36*, 3945–3955. doi:10.1109/TPWRD.2021.3051531.
94. Wenlin, J. GE Strengthens Power Supply in Anglesey. Available online: <https://www.gepowerconversion.com/press-releases/ge-supports-power-grids-future-europe's-first-mvdc-link> (accessed on 19 February 2021).
95. Siemens, A.G. *MVDC Plus Managing the Future Grid*; Whitepaper; Siemens: Munich, Germany, 2017. <https://new.siemens.com/uk/en/products/energy/medium-voltage/solutions/mvdc.html#Ordertechnicaldetails> (accessed 7 December 2021).
96. Liu, S.; Zhao, Y.; Chen, L.; Si, Z. Research on Control and Protection Strategy and Design Scheme of VSC-DC Distribution Network Control and Protection System. *Distrib. Util.* **2018**, *35*, 34–39.
97. Rivera, S.; Lizana, F.R.; Kouro, S.; Dragicevic, T.; Wu, B. Bipolar DC Power Conversion: State-of-the-Art and Emerging Technologies. *IEEE J. Emerg. Sel. Top. Power Electron.* **2021**, *9*, 1192–1204, doi:10.1109/JESTPE.2020.2980994.
98. Jambrich, G.; Stöckl, J.; Makoschitz, M. MVDC ring-cable approach for new DC distribution and restructured AC grids. In Proceedings of the 2019 IEEE Third International Conference on DC Microgrids (ICDCM), Matsue, Japan, 20–23 May 2019; pp. 1–5.
99. Abeynayake, G.; Li, G.; Joseph, T.; Ming, W.; Moon, A.; Smith, K.; Yu, J. Reliability Evaluation of Voltage Source Converters for MVDC Applications. *IEEE PESS Innov. Smart Grid Technol. Asia* **2019**, 2566–2570.
100. Cui, S.; Hu, J.; De Doncker, R.W. Control and Experiment of a TLC-MMC Hybrid DC-DC Converter for the Interconnection of MVDC and HVDC Grids. *IEEE Trans. Power Electron.* **2020**, *35*, 2353–2362, doi:10.1109/TPEL.2019.2928258.
101. Bosich, D.; Mastromauro, R.A.; Sulligoi, G. AC-DC interface converters for MW-scale MVDC distribution systems: A survey. In Proceedings of the 2017 IEEE Electric Ship Technologies Symposium, ESTS 2017, Arlington, VA, USA, 14–17 August 2017; pp. 44–49.
102. Shi, L.; Adam, G.P.; Li, R.; Xu, L. Enhanced Control of Offshore Wind Farms Connected to MTDC Network Using Partially Selective DC Fault Protection. *IEEE J. Emerg. Sel. Top. Power Electron.* **2020**, *9*, 2926–2935, doi:10.1109/jestpe.2020.2985129.
103. ABB ForSea (Formerly HH Ferries Group) Completes Conversion of the World's Largest Batter Ferries, Powered by ABB. Available online: <https://new.abb.com/news/detail/10434/forsea-formerly-hh-ferries-group-completes-conversion-of-the-worlds-largest-battery-ferries-powered-by-abb> (accessed on 2 March 2021).
104. Kongsberg Energy Products. Available online: <https://www.kongsberg.com/maritime/products/electrical-power-system/energy-products/> (accessed on 22 April 2021).
105. Okeke, T.U.; Zaher, R.G. Flexible AC Transmission Systems (FACTS). In Proceedings of the 2013 International Conference on New Concepts in Smart Cities: Fostering Public and Private Alliances (SmartMILE), Gijon, Spain, 11–13 December 2013; pp. 1–4.
106. Bernacchi, R. *MVDC and Grid Interties: Enabling New Features in Distribution, Sub-Transmission and Industrial Networks*; ABB: Zurich, Switzerland, 2019.
107. UK Power Networks. *High-Level Design Specification of Advanced Automation Solution: Active Response—Project Deliverable 1*; UK Power Networks: London, UK, 2019.
108. Li, B.; Liang, Y.; Wang, G.; Li, H.; Ding, J. A control strategy for soft open points based on adaptive voltage droop outer-loop control and sliding mode inner-loop control with feedback linearization. *Int. J. Electr. Power Energy Syst.* **2020**, *122*, 106205, doi:10.1016/j.ijepes.2020.106205.
109. Yu, J.; Macleod, N.; Smith, K.; Moon, A. *NIC Project Medium Voltage Direct Current Link Technical Specification NIC Project Medium Voltage Direct Current Link Technical Specification*; Scottish Power Energy Networks: Glasgow, UK, 2017.
110. Fotopoulou, M.; Rakopoulos, D.; Trigkas, D.; Stergiopoulos, F.; Blanas, O.; Voutetakis, S. State of the art of low and medium voltage direct current (DC) microgrids. *Energies* **2021**, *14*, 5595, doi:10.3390/en14185595.
111. Yang, M.; Xie, D.; Zhu, H.; Lou, Y. Architectures and control for multi-terminal DC (MTDC) distribution network—A review. *IET Semin. Dig.* **2015**, *2015*, doi:10.1049/cp.2015.0100.
112. Jovicic, D.; Taherbaneh, M.; Taisne, J.P.; Nguéfeu, S. Offshore DC grids as an interconnection of radial systems: Protection and control aspects. *IEEE Trans. Smart Grid* **2015**, *6*, 903–910, doi:10.1109/TSG.2014.2365542.
113. Prakash, K.; Lallu, A.; Islam, F.R.; Mamun, K.A. Review of Power System Distribution Network Architecture. In Proceedings of the 2016 3rd Asia-Pacific World Congress on Computer Science and Engineering (APWC on CSE), Nadi, Fiji, 5–6 December 2016, 124–130, doi:10.1109/APWC-on-CSE.2016.030.
114. Augustine, S.; Quiroz, J.E.; Reno, M.J.; Brahma, S. *DC Microgrid Protection: Review and Challenges*; Sandia National Laboratories: Albuquerque, NM, USA, 2018.

115. Pinto, R.T.; Rodrigues, S.; Bauer, P.; Pierik, J. Operation and control of a multi-terminal DC network. In Proceedings of the 2013 IEEE ECCE Asia Downunder, Melbourne, VIC, Australia, 3–6 June 2013; pp. 474–480, doi:10.1109/ECCE-Asia.2013.6579139.
116. Korompili, A.; Sadu, A.; Ponci, F.; Monti, A. Flexible electric networks of the future: Project on control and automation in MVDC grids. In *International ETG Congress 2015; Die Energiewende—Blueprints for the New Energy Age*; Bonn, Germany, Bonn, Germany, 2015; pp. 556–563.
117. Zhuo, Z.; Zhang, N.; Kang, C.; Dong, R.; Liu, Y. Optimal Operation of Hybrid AC/DC Distribution Network with High Penetrated Renewable Energy. In Proceedings of the 2018 IEEE Power & Energy Society General Meeting (PESGM), Portland, OR, USA, 5–10 August 2018, doi:10.1109/PESGM.2018.8585802.
118. Musa, A.; Rehan, S.; Sabug, L.; Ponci, F.; Monti, A. Modeling and design of hybrid distribution network: Operational and technical features. In Proceedings of the 2017 IEEE PES Innovative Smart Grid Technologies Conference Europe (ISGT-Europe), Turin, Italy, 26–29 September 2017, pp. 1–6, doi:10.1109/ISGTEurope.2017.8260207.
119. Rouhani, M.; Kish, G.J. Multiport DC–DC–AC Modular Multilevel Converters for Hybrid AC/DC Power Systems. *IEEE Trans. Power Deliv.* **2020**, *35*, 408–419.
120. Jafarishiadeh, S.; Dargahi, V.; Sadigh, A.K.; Farasat, M. Novel multi-terminal MMC-based dc/dc converter for MVDC grid interconnection. *IET Power Electron.* **2018**, *11*, 1266–1276, doi:10.1049/iet-pel.2017.0164.
121. Zhao, B.; Zeng, R.; Song, Q.; Yu, Z.; Qu, L. Medium-voltage DC power distribution technology. In *The Energy Internet: An Open Energy Platform to Transform Legacy Power Systems into Open Innovation and Global Economic Engines*; Su, W., Huang, A.Q., Eds.; Woodhead Publishing: Sawston, UK, 2019; pp. 123–152; ISBN 9780081022078.
122. Thielemans, S.; Vyncke, T.J.; Melkebeek, J.A.A. Voltage Quality Analysis of a Three-Level Flying Capacitor Inverter with Model Based Predictive Control. In Proceedings of the 8th International Conference on Power Electronics—ECCE Asia, Jeju, Korea, 30 May–3 June 2011, pp. 124–131, doi:10.1109/ICPE.2011.5944560.
123. Wang, J.; Yang, S.; Yang, W. Harmonic reduction for 12-pulse four star thyristor rectifier with active auxiliary circuit. In Proceedings of the 2015 IEEE 11th International Conference on Power Electronics and Drive Systems, Sydney, NSW, Australia, 9–12 June 2015; pp. 301–306, doi:10.1109/PEDS.2015.7203484.
124. Guo, C.; Li, C.; Zhao, C.; Ni, X.; Zha, K.; Xu, W. An Evolutional Line-Commutated Converter Integrated with Thyristor-Based Full-Bridge Module to Mitigate the Commutation Failure. *IEEE Trans. Power Electron.* **2017**, *32*, 967–976, doi:10.1109/TPEL.2016.2544107.
125. Wang, F.; Bertling, L.; Le, T.; Mannikoff, A.; Bergman, A. An overview introduction of VSC-HVDC: State-of-art and potential applications in electric power systems. CIGRE 2011 Bologna Symposium—The Electric Power System of the Future: Integrating Supergrids and Microgrids, Bologna, Italy, 13–15 September 2011.
126. Huang, X.; Qi, L.; Pan, J. A New Protection Scheme for MMC-Based MVdc. *IEEE Trans. Ind. Appl.* **2019**, *55*, 4515–4523.
127. Li, B.; Li, Y.; He, J. Electrical Power and Energy Systems A DC fault handling method of the MMC-based DC system q. *Electr. Power Energy Syst.* **2017**, *93*, 39–50, doi:10.1016/j.ijepes.2017.05.011.
128. Siemens M2C—It’s Short for “Innovation”. Available online: <https://new.siemens.com/global/en/products/drives/sinamics/medium-voltage-converters/m2c-technology.html#:~:text=Modular multilevel converters display their strengths in combination,energy%2C offshore and the metal industry%2C for example> (accessed on 5 May 2021).
129. Adam, G.P.; Anaya-lara, O.; Burt, G.; Mcdonald, J. Comparison between Two VSC-HVDC Transmission Systems Technologies : Modular and Neutral Point Clamped Multilevel Converter. In Proceedings of the Event IECON 2009, the 35th Annual Conference of the IEEE Industrial Electronics Society and ICELIE 2009, the 3rd IEEE International Conference on E-Learning in Industrial Electronics, Porto, Portugal, 3–5 September 2009.
130. Sun, J.; Liu, H. Impedance modeling and analysis of modular multilevel converters. In Proceedings of the 2016 IEEE 17th Workshop on Control and Modeling for Power Electronics (COMPEL), Trondheim, Norway, 27–30 June 2016. doi:10.1109/COMPEL.2016.7556781.
131. Konstantinou, G.; Pou, J.; Ceballos, S.; Agelidis, V.G. Active redundant submodule configuration in modular multilevel converters. *IEEE Trans. Power Deliv.* **2013**, *28*, 2333–2341, doi:10.1109/TPWRD.2013.2264950.
132. Vozikis, D.; Adam, G.P.; Rault, P.; Tzelepis, D.; Holliday, D.; Finney, S. Steady-state performance of state-of-the-art modular multilevel and alternate arm converters with DC fault-blocking capability. *Int. J. Electr. Power Energy Syst.* **2018**, *99*, 618–629, doi:10.1016/j.ijepes.2018.01.054.
133. Hagiwara, M.; Akagi, H. Control and Experiment of Pulsewidth-Modulated Modular Multilevel Converters. *IEEE Trans. Power Electron.* **2009**, *24*, 1737–1746, doi:10.1109/TPEL.2009.2014236.
134. Ansari, J.A.; Liu, C.; Khan, S.A. MMC Based MTDC Grids: A Detailed Review on Issues and Challenges for Operation, Control and Protection Schemes. *IEEE Access* **2020**, *8*, 168154–168165, doi:10.1109/access.2020.3023544.
135. Qin, J.; Saeedifard, M.; Rockhill, A.; Zhou, R. Hybrid design of modular multilevel converters for HVDC systems based on various submodule circuits. *IEEE Trans. Power Deliv.* **2015**, *30*, 385–394, doi:10.1109/TPWRD.2014.2351794.
136. Deng, F.; Lü, Y.; Liu, C.; Heng, Q.; Yu, Q.; Zhao, J. Overview on submodule topologies, modeling, modulation, control schemes, fault diagnosis, and tolerant control strategies of modular multilevel converters. *Chin. J. Electr. Eng.* **2020**, *6*, 1–21, doi:10.23919/CJEE.2020.000001.
137. Zhao, B.; Zeng, R.; Li, J.; Wei, T.; Chen, Z.; Song, Q.; Yu, Z. Practical Analytical Model and Comprehensive Comparison of Power Loss Performance for Various MMCs Based on IGCT in HVDC Application. *IEEE J. Emerg. Sel. Top. Power Electron.* **2019**, *7*, 1071–1083, doi:10.1109/JESTPE.2018.2871191.

138. Yin, T.; Xu, C.; Lin, L.; Jing, K. A SiC MOSFET and Si IGBT Hybrid Modular Multilevel Converter with Specialized Modulation Scheme. *IEEE Trans. Power Electron.* **2020**, *35*, 12623–12628, doi:10.1109/TPEL.2020.2993366.
139. GE Siemens. *MV7000 Flat Pack (FP)*; Siemens: Munich, Germany, 2019.
140. B4-110, CIGRE; Jacobson, B.; Karlsson, P.; Asplund, G.; Harnefors, L.T.J. VSC-HVDC Transmission with Cascaded Two-Level Converters Converter Topology and Main Circuit; ABB, Sweden, 2010. Available online: [https://library.e.abb.com/public/422dcbc564d7a3e1c125781c00507e47/B4-110\\_2010%20-%20VSC-HVDC%20Transmission%20with%20Cascaded%20Two-level%20converters.pdf](https://library.e.abb.com/public/422dcbc564d7a3e1c125781c00507e47/B4-110_2010%20-%20VSC-HVDC%20Transmission%20with%20Cascaded%20Two-level%20converters.pdf) (accessed 7 December 2021).
141. Alhurayyis, I.; Member, S.; Elkhateb, A.; Member, S.; Morrow, D.J. Isolated and Non-Isolated DC-to-DC Converters for Medium Voltage DC Networks: A Review. *IEEE J. Emerg. Sel. Top. Power Electron.* **2020**, *9*, 7486–7500.
142. Erickson, R.W.; Maksimović, D. *Fundamentals of Power Electronics*, 2nd ed.; Springer Science+Business Media: Berlin, Germany, 2013; Volume 59, ISBN 9781447151036.
143. Chewale, M.A.; Wanjari, R.A.; Savakhande, V.B.; Sonawane, P.R. A Review on Isolated and Non-isolated DC-DC Converter for PV Application. In Proceedings of the 2018 International Conference on Control, Power, Communication and Computing Technologies, ICCPCCT 2018, Kerala, India, 23–24 March 2018; IEEE: Piscataway, NJ, USA, 2018; pp. 399–404.
144. Hou, N.; Song, W.; Zhu, Y.; Sun, X.; Li, W. Dynamic and static performance optimization of dual active bridge DC-DC converters. *J. Mod. Power Syst. Clean Energy* **2018**, *6*, 607–618, doi:10.1007/s40565-017-0343-7.
145. Alhurayyis, I.; Elkhateb, A.; Morrow, D.J. Bidirectional DC-DC Resonant Converter Design for Electric Vehicle Charging Stations Integration to MVDC Grids. In Proceedings of the 9th International Conference on Renewable Energy Research and Applications, Glasgow, UK, 27–30 September 2020; pp. 236–241.
146. Stojadinović, M. Bidirectional DC-DC Converters for MVDC Applications. Doctoral Thesis, ETH Zurich, Zürich, Switzerland, 2020.
147. Wang, L.; Zhu, Q.; Yu, W.; Huang, A.Q. A Medium-Voltage Medium-Frequency Isolated DC-DC Converter Based on 15-kV SiC MOSFETs. *IEEE J. Emerg. Sel. Top. Power Electron.* **2017**, *5*, 100–109, doi:10.1109/JESTPE.2016.2639381.
148. Kish, G.J. On the emerging class of non-isolated modular multilevel DC-DC converters for DC and hybrid AC-DC systems. *IEEE Trans. Smart Grid* **2019**, *10*, 1762–1771, doi:10.1109/TSG.2017.2777473.
149. Kish, G.J.; Lehn, P.W. A comparison of Modular Multilevel Energy Conversion Processes: DC/AC versus DC/DC. *IEEE J. Ind. Appl.* **2015**, *4*, 370–379, doi:10.1541/ieejia.4.370.
150. Ashraf, M.; Nazih, Y.; Alsokhry, F.; Ahmed, K.H.; Abdel-khalik, A.S.; Al-Turki, Y. A New Hybrid Dual Active Bridge Modular Multilevel Based DC-DC Converter for HVDC Networks. *IEEE Access* **2021**, *9*, 62055–62073. doi:10.1109/ACCESS.2021.3074543.
151. Ferreira, J.A. The multilevel modular DC converter. *IEEE Trans. Power Electron.* **2013**, *28*, 4460–4465, doi:10.1109/TPEL.2012.2237413.
152. Xiang, X. *The Modular Multilevel DC Converters for MVDC and HVDC Applications*; Imperial College London: London, UK, 2019.
153. Zahedi, B. Shipboard DC Hybrid Power Systems: Modeling, Efficiency Analysis and Stability Control. Ph.D. Thesis, NTNU-Norwegian University of Science and Technology, Trondheim, Norway, 2014.
154. Sun, C.; Cai, X.; Zhang, J.; Shi, G. A Modular Multilevel DC-DC Converter with Self Voltage Balancing and Soft Switching. In Proceedings of the 2018 IEEE International Power Electronics and Application Conference and Exposition (PEAC), Shenzhen, China, 4–7 December 2018, pp. 12–17, doi:10.1109/PEAC.2018.8590357.
155. Engel, S.P.; Stieneker, M.; Soltan, N.; Rabiee, S.; Stagge, H.; Doncker, R.W. De Comparison of the Modular Multilevel DC Converter and the Dual-Active Bridge Converter for Power Conversion in HVDC and MVDC Grids. *IEEE Trans. Power Electron.* **2015**, *30*, 124–137.
156. Scottish Power Energy Networks. *LV Engine – Project Overview*; Scottish Power Energy Networks: Glasgow, UK, 2018.
157. Wang, R.; Zhang, B.; Zhao, S.; Liang, L.; Chen, Y. Design of an IGBT-series-based Solid-State Circuit Breaker for Battery Energy Storage System Terminal in Solid-State Transformer. In Proceedings of the IECON 2019—45th Annual Conference of the IEEE Industrial Electronics Society, Lisbon, Portugal, 14–17 October 2019; IEEE: Piscataway, NJ, USA, 2019; pp. 6677–6682. doi:10.1109/IECON.2019.8926684
158. Liserre, M.; Buticchi, G.; Andresen, M.; De Carne, G.; Costa, L.F.; Zou, Z.X. The Smart Transformer: Impact on the Electric Grid and Technology Challenges. *IEEE Ind. Electron. Mag.* **2016**, *10*, 46–58, doi:10.1109/MIE.2016.2551418.
159. Hrishikesan, V.M.; Kumar, C. Smart Transformer Based Meshed Hybrid Microgrid with MVDC Interconnection. In Proceedings of the IECON 2020 the 46th Annual Conference of the IEEE Industrial Electronics Society, Singapore, 18–21 October 2020; pp. 4961–4966, doi:10.1109/IECON43393.2020.9255284.
160. Aithal, A.; Wu, J. Operation and Performance of a Medium Voltage DC Link. In Proceedings of the 24th International Conference on Electricity Distribution, Glasgow, UK, 12–15 June 2017; Volume 5, pp. 12–15.
161. Andersen, M.; De Carne, G. *LV Engine Smart Transformer Hardware, Power Converter Control and Reliability*; Scottish Power Energy Networks: Glasgow, UK, 2018.
162. Allca-Pekarovic, A.; Kollmeyer, P.J.; Mahvelatishamsabadi, P.; Mirfakhrai, T.; Naghshtabrizi, P.; Emadi, A. Comparison of IGBT and SiC Inverter Loss for 400V and 800V DC Bus Electric Vehicle Drivetrains. In Proceedings of the 2020 IEEE Energy Conversion Congress and Exposition (ECCE), Detroit, MI, USA, 11–15 October 2020; pp. 6338–6344, doi:10.1109/ECCE44975.2020.9236202.

163. Palanisamy, S.; Basler, T.; Lutz, J.; Kunzel, C.; Wehrhahn-Kilian, L.; Elpelt, R. Investigation of the bipolar degradation of SiC MOSFET body diodes and the influence of current density. *IEEE Int. Reliab. Phys. Symp. Proc.* **2021**, *3*, 1–6, doi:10.1109/IRPS46558.2021.9405183.
164. Ong, A.; Carr, J.; Balda, J.; Mantooth, A. A comparison of silicon and silicon carbide MOSFET switching characteristics. In Proceedings of the 2007 IEEE Region 5 Technical Conference, Fayetteville, AR, USA, 20–22 April 2007; pp. 273–277, doi:10.1109/TPSD.2007.4380318.
165. Liang, Y.C.; Samudra, G.S.; Huang, C.-F. Insulated-Gate Bipolar Transistor. *Power Microelectron.* **2017**, 191–248, doi:10.1142/9789813200258\_0005.
166. Noh, C.H.; Kim, C.H.; Gwon, G.H.; Khan, M.O.; Jamali, S.Z. Development of protective schemes for hybrid AC/DC low-voltage distribution system. *Int. J. Electr. Power Energy Syst.* **2019**, *105*, 521–528, doi:10.1016/j.ijepes.2018.08.030.
167. Guillod, T.; Krismer, F.; Kolar, J.W. Protection of MV Converters in the Grid: The Case of MV/LV Solid-State Transformers. *IEEE J. Emerg. Sel. Top. Power Electron.* **2017**, *5*, 393–408, doi:10.1109/JESTPE.2016.2617620.
168. Li, G.; Liang, J.; Balasubramaniam, S.; Joseph, T.; Ugalde-Loa, C.E.; Jose, K.F. Frontiers of DC Circuit Breakers in HVDC and MVDC Systems. In Proceedings of the 2017 IEEE Conference on Energy Internet and Energy System Integration, Beijing, China, 26–28 November 2017; pp. 1–6.
169. Ding, C.; Nie, T.; Tian, X.; Chen, T.; Yuan, Z. Analysis of the influence of RC buffer on DC solid-state circuit breaker. *Energy Rep.* **2020**, *6*, 1483–1489, doi:10.1016/j.egy.2020.10.066.
170. Nguyen, A.-D.; Nguyen, T.-T.; Kim, H.-M. A Comparison of Different Hybrid Direct Current Circuit Breakers for Application in HVDC System. *Int. J. Control Autom.* **2016**, *9*, 381–394, doi:10.14257/ijca.2016.9.4.37.
171. Zheng, T.; Lv, W.; Wu, Q.; Li, R.; Liu, X.; Zhang, T.; Xu, L. An Integrated Control and Protection Scheme Based on FBSM-MMC Active Current Limiting Strategy for DC Distribution Network. *IEEE J. Emerg. Sel. Top. Power Electron.* **2021**, *9*, 2632–2642, doi:10.1109/JESTPE.2020.3014795.
172. Li, B.; He, J.; Li, Y.; Li, B. A review of the protection for the multi-terminal VSC-HVDC grid. *Prot. Control Mod. Power Syst.* **2019**, *4*, 21. doi:10.1186/s41601-019-0136-2.
173. Egea-Alvarez, A.; Ferré, A.J.; Gomis-Bellmunt, O. Active and Reactive Power Control of Grid Connected Distributed Generation System. In *Green Energy and Technology*; Springer: Berlin/Heidelberg, Germany, 2012; pp. 47–81, ISBN 9781509032389.
174. Pattabiraman, D.; Lasseter, R.H.; Jahns, T.M. Comparison of Grid Following and Grid Forming Control for a High Inverter Penetration Power System. In Proceedings of the 2018 IEEE Power & Energy Society General Meeting (PESGM), Portland, OR, USA, 5–10 August 2018; pp. 3–7. doi:10.1109/PESGM.2018.8586162.
175. Bevrani, H.; Ise, T.; Miura, Y. Virtual synchronous generators: A survey and new perspectives. *Int. J. Electr. Power Energy Syst.* **2014**, *54*, 244–254, doi:10.1016/j.ijepes.2013.07.009.
176. Abdelrahim, A.A.; Smailes, M.; Ahmed, K.; Mckeever, P.; Egea-alvarez, A. Modified grid forming converter controller with fault ride through capability without PLL or current loop. In Proceedings of the 18th Wind Integration Workshop, Dublin, Ireland, 16–18 October 2019; pp. 1–8.
177. Morren, J.; de Haan, S.W.H.; Kling, W.L.; Ferreira, J.A. Wind turbines emulating inertia and supporting primary frequency control. *IEEE Trans. Power Syst.* **2006**, *21*, 433–434, doi:10.1109/TPWRS.2005.861956.
178. Castelo De Oliveira, T.E.; Van Overbeeke, F.; Cuk, V.; De Jong, E.C.W. MVDC Application: Switching Processes AC-to-DC, DC -to- AC and Imbalance Mitigation through DC Mode. In Proceedings of the 2019 IEEE PES Innovative Smart Grid Technologies Europe (ISGT-Europe), Bucharest, Romania, 29 September–2 October 2019; pp. 1–5, doi:10.1109/ISGTEurope.2019.8905558.
179. Chai, R.; Zhang, B.; Dou, J. Improved DC voltage margin control method for DC grid based on VSCs. In Proceedings of the 2015 IEEE 15th International Conference on Environment and Electrical Engineering (EEEIC), Rome, Italy, 10–13 June 2015; pp. 1683–1687, doi:10.1109/EEEIC.2015.7165425.
180. Korompili, A.; Monti, A. Analysis of the dynamics of dc voltage droop controller of DC-DC converters in multi-terminal dc grids. In Proceedings of the 2017 IEEE Second International Conference on DC Microgrids (ICDCM), Nuremberg, Germany, 27–29 June 2017; pp. 507–514, doi:10.1109/ICDCM.2017.8001094.
181. Simiyu, P.; Xin, A.; Bitew, G.T.; Shahzad, M.; Kunyu, W.; Tuan, L.K. Review of the DC voltage coordinated control strategies for multi-terminal VSC-MVDC distribution network. *J. Eng.* **2019**, *2019*, 1462–1468, doi:10.1049/joe.2018.8841.
182. Wang, Y.; Wen, W.; Wang, C.; Liu, H.; Zhan, X.; Xiao, X. Adaptive Voltage Droop Method of Multiterminal VSC-HVDC Systems for DC Voltage Deviation and Power Sharing. *IEEE Trans. Power Deliv.* **2019**, *34*, 169–176, doi:10.1109/TPWRD.2018.2844330.
183. Torres, F.; Martinez, S.; Roa, C.; Lopez, E. Comparison between voltage droop and voltage margin controllers for MTDC systems. In Proceedings of the IEEE ICA-ACCA 2018—IEEE International Conference on Automation/23rd Congress of the Chilean Association of Automatic Control: Towards an Industry 4.0—Proceedings, Concepcion, Chile, 17–19 October 2018.
184. Egea-Alvarez, A.; Beerten, J.; Van Hertem, D.; Gomis-Bellmunt, O. Hierarchical power control of multiterminal HVDC grids. *Electr. Power Syst. Res.* **2015**, *121*, 207–215, doi:10.1016/j.epsr.2014.12.014.
185. Taft, J. *Roles and Responsibilities for Distribution Grids: DER Sensing and Communication Networks*; Pacific Northwest National Laboratory: Richland, DC, USA, 2017.
186. Abedrabbo, M.; Wang, M.; Tielens, P.; Dejene, F.Z.; Leterme, W.; Beerten, J.; Van Hertem, D. Impact of DC grid contingencies on AC system stability. *IET Conf. Publ.* **2017**, *2017*, 1–7, doi:10.1049/cp.2017.0025.
187. Ji, Y.; Yuan, Z.; Zhao, J.; Lu, C.; Wang, Y.; Zhao, Y.; Li, Y.; Han, Y. Hierarchical control strategy for MVDC distribution network under large disturbance. *IET Gener. Transm. Distrib.* **2018**, *12*, 2557–2565, doi:10.1049/iet-gtd.2017.1642.

188. Glende, E.; Trojan, P.; Hauer, I.; Naumann, A.; Brosinsky, C.; Wolter, M.; Westermann, D. Communication Infrastructure for Dynamic Grid Control Center with a Hardware-in-The-Loop Model. In Proceedings of the 2018 IEEE PES Innovative Smart Grid Technologies Conference Europe (ISGT-Europe), Sarajevo, Bosnia and Herzegovina, 21–25 October 2018, pp. 8–13, doi:10.1109/ISGTEurope.2018.8571464.
189. Basu, M.; Mahindara, V.R.; Kim, J.; Nelms, R.M.; Muljadi, E. Comparison of Active and Reactive Power Oscillation Damping With PV Plants. *IEEE Trans. Ind. Appl.* **2021**, *57*, 2178–2186, doi:10.1109/TIA.2021.3059810.
190. Hunter, L.C.; Booth, C.D.; Egea-Alvarez, A.; Dysko, A.; Finney, S.J.; Junyent-Ferre, A. A new fast-acting backup protection strategy for embedded MVDC links in future distribution networks. *IEEE Trans. Power Deliv.* **2021**, *36*, 861–869, doi:10.1109/TPWRD.2020.2995479.
191. Hadjikypris, M.; Marjanovic, O.; Terzija, V. Damping of inter-area power oscillations in hybrid AC-DC power systems based on supervisory control scheme utilizing FACTS and HVDC. In Proceedings of the 19th Power Systems Computation Conference, PSCC 2016; Power Systems Computation Conference, Genoa, Italy, 20–24 June 2016.