

Flow Injection Analysis of Acid and Base using Thermo-Sensitive Resistance Coils

journal or publication title	Journal of Flow Injection Analysis
volume	12
number	1
page range	66-76
year	1995-06
その他の言語のタイトル	感温抵抗コイルを用いる酸と塩基のフローインジェクション分析
URL	http://hdl.handle.net/2298/11008

Flow Injection Analysis of Acid and Base using Thermo-Sensitive Resistance Coils

Kei TODA*, Senju IWATA, Isao SANEMASA and Toshio DEGUCHI

*Department of Chemistry, Faculty of Science,
Kumamoto University, Kurokami, Kumamoto 860, Japan*

ABSTRACT

A flow injection analysis of acid-base by detecting neutralization heat is proposed. A injected sample (acid or base), combined with a carrier (deionized water), was mixed with a reagent (base or acid) stream. A change in the solution temperature was detected by passing the solution, immediately after mixing, through a stainless steel capillary tube around which a thermo-sensitive resistance was coiled. The temperature of carrier was used as a reference. Hydrochloric acid solutions of 0.003 to 0.2 M could be determined at a rate of 120 samples/h. Using this system, determination in weak-acid and weak-base system could also be performed. Thermo-sensitive resistances used in this work were completely free from corrosion, and effects of the ambient temperature and the sample diffusion in the detector were minimized.

Introduction

Acid-base titrations popular in analytical chemistry usually employ indicators to detect the end-point. A new-type mixer has been proposed to facilitate flow injection titration analysis.¹ The color change of indicator,

however, is of no use for colored sample solutions. In this case, a pH-sensitive glass electrode is suitable to detect the pH change, but a specially designed flow cell is needed for the determination.² Moreover, it is difficult to clearly detect end-points of weak acid-weak base titrations due to their gentle pH jumps. In order to overcome these difficulties, some workers have made use of neutralization heat to detect end-points.³⁻⁶ These thermometric titrations however, were made under batchwise conditions. In the batch method particular attentions should be paid to an external heat.

A thermometric titration coupled with a FIA technique, which sometimes called flow enthalpimetry, has been recently proposed.⁷⁻¹⁰ Hard design used for flow enthalpimetry and their applications are described in detail.¹¹ Because of its high sensitivity to a heat change, a thermistor, which resistance changes steeply according to temperature, was used in these studies to detect the heat of neutralization. The thermistor, however, is liable to be corroded, because it is placed inside a tube through which an acidic or alkaline solution is continuously passing. The thermistor coated with glass may be used to protect against corrosion, but the heat-capacity of such sensor becomes large and moreover, the tube should be large enough to include the sensor. The output signal of the thermistor-type detector depend on ambient temperature because the relation of resistance and temperature is not linear. And ambient temperature compensation using reference thermistor is difficult because of the variedness of their temperature coefficient of resistance.

In this work, a system to detect the heat of neutralization with thermosensitive resistances was proposed. Using this system, the effect of ambient temperature on heat measurements was reduced and, because the heat was measured outside the tube, the sensor was completely free from corrosion.

EXPERIMENTAL

Heat detector

The structure of the heat detector part used in this work is shown in Fig. 1. Thermo-sensitive resistance wire was coiled around a stainless steel 304 capillary tube (o.d. $0.88 \times t 0.15 \times 100$ mm); the number of coil was controlled so as to get the resistance of ca. $1 \text{ k}\Omega$. The resistance wire was made of Ni (70%) and Fe (30%), its diameter was $\phi 18 \pm 2 \mu\text{m}$, resistance ratio was $240 \pm 10 \Omega/\text{feet}$ at 25°C , and its temperature coefficient (TCR) was $4400 \text{ ppm}/^\circ\text{C}$. The wire was coated with $4 \pm 1 \mu\text{m}$ poly-imide (Toreneese #3000, Tore) to insulate. The ends of the wire were barked by a sandpaper (#1000) and soldered to a electric circuit.

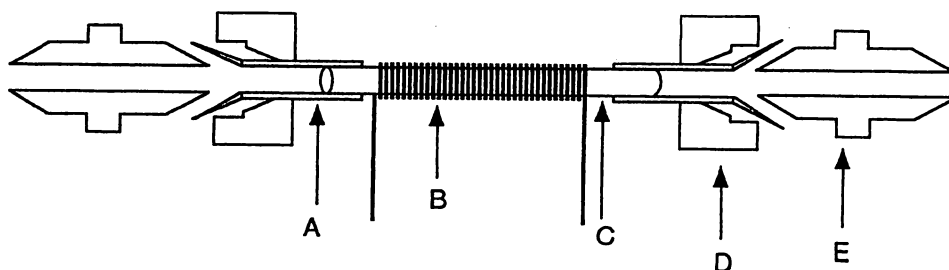

Fig. 1 Structure of heat detector

A: PTFE tube (i. d. 0.5×50 mm), B: Fe-Ni wire,
C: stainless steel capillary (o. d. $0.88 \times t 0.15 \times 50$ mm)
D: nut, E: union connector

Apparatus

The schematic diagram used in this work is shown in Fig. 2. The flow system was constructed of PTFE tubing (2 mm o.d. and 1 mm i.d.). The carrier (deionized water) and reagent (base or acid) solution were made to flow continuously by applying nitrogen pressure of $0.5 \sim 1.0 \text{ kg}^f/\text{cm}^2\text{G}$ ($4.9 \sim 9.8 \times$

10⁴ Pa) to each reservoir (500 or 1000 ml PYREX glass separable flask); the flow rate was regulated by a needle valve made of tetrafluoroethylene-perfluorovinyl ether copolymer (PFA type mini needle flare LFN-2, Iuchi-Seieido) attached to the outlet of each reservoir. Sample solution was introduced to a sample loop of 60 μ l by syringe sucking. The detector, shown in Fig 1, was connected to the carrier line before a sample injector; this serves as a reference detector (REF). At the downstream of a mixing point where the carrier and the reagent were to be mixed, another detector was connected; this serves as a working detector (SEN). The distance between the mixing point and the center of the detector (SEN) was 150 mm. The water bath used in this work was not thermostated. Sample, carrier, and reagent solutions are after being passed through each heat-exchange coil of 1 m length made of the PIPE tubing to attain a constant temperature equal to that of the water bath.

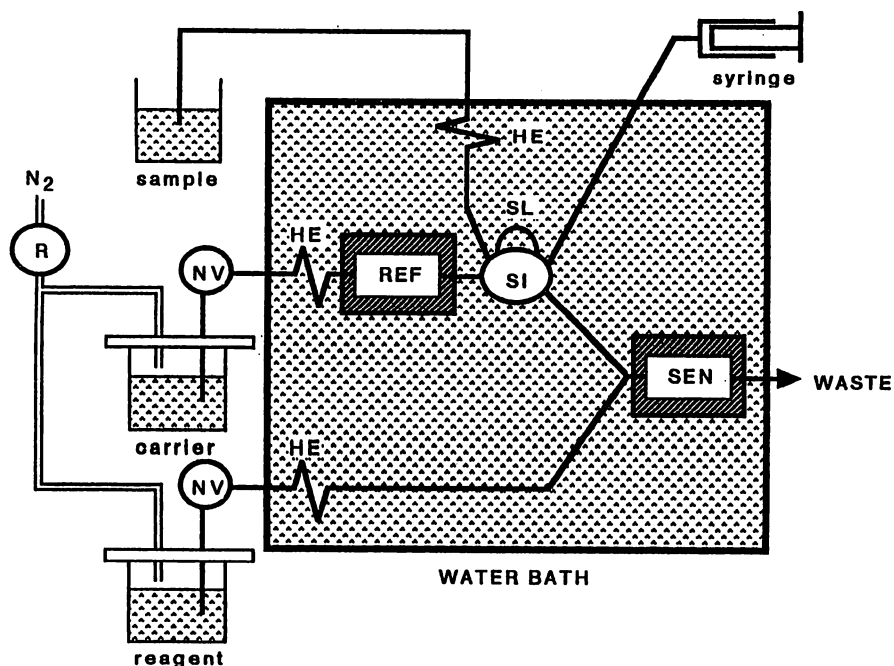

Fig. 2 Schematic diagram of the FIA system

R : pressure regulator, NV : needle valve, HE : heat-exchange coil,
 SI : sample injector, SL : sample loop,
 REF : reference detector, SEN : working detector

Detection circuit

The circuit to detect a temperature change is shown in Fig.3. Two detectors, SEN and REF, were combined to a Wheatstone bridge. The change in this bridge balance was monitored. The voltage applied at the head of the bridge was only 0.45 V. In an amplification of difference part, an instrumentation amplifier with three operational amplifier units was used to obtain a good accuracy. An amplification ratio was about $\times 21$. The bridge balance was adjusted by a variable resistor (VR1). In order to reduce the signal-to-noise ratio, a pass-condenser (0.1 μF) was connected to the power supply of the operational amplifier, and the integral circuit, which time constant was 0.5 msec, was attached to the output terminal. In the combination of the sensor and the circuit described above, the output signal was changed about 10 mV when the coil temperature changed by 1°C.

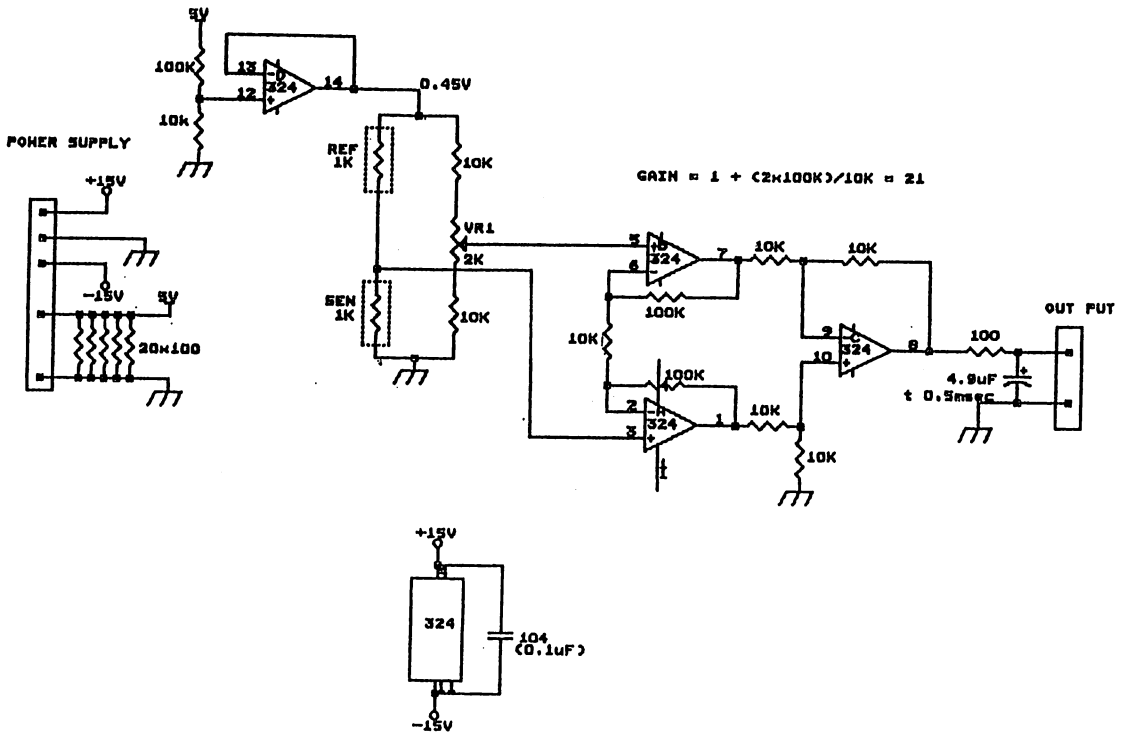

Fig. 3 Detection circuit for thermometric determination

Reagents

All of the reagents used in this investigation were of guaranteed grade, and deionized water was used as the diluent or the carrier. The base solutions were standardized by sulfamic acid, and the acid solutions were standardized by this base solution using conventional titration. These solutions were degassed before use to prevent cavitation at the flow control valves.

RESULTS AND DISCUSSION

The voltage applied to the bridge head was regulated to be 0.45 V. This low voltage produced a relatively small final signal output, but was nevertheless chosen to reduce self-heating of SEN or REF. The supplied power under this condition to the temperature-measuring resistance was only 50 μW , which was estimated to correspond to a neutralization heat of an 1.5×10^{-5} M HCl sample injected with NaOH solution. This estimation shows that the resistor self-heating is negligible under the present condition.

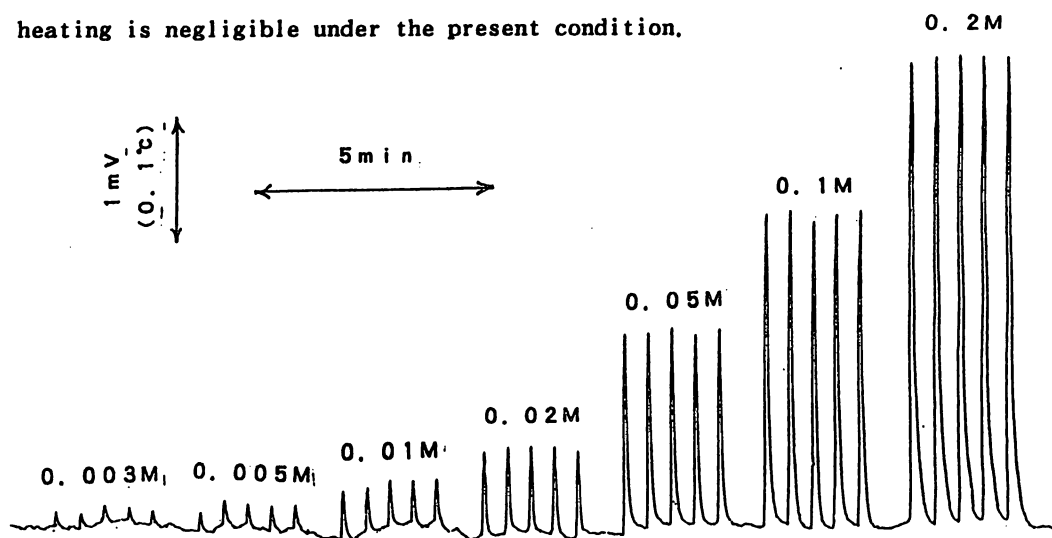

Fig. 4 Flow signals obtained in HCl sample-NaOH reagent system
sample : 0.003 ~ 0.2 M HCl, reagent : 0.2 M NaOH 1ml/min
carrier : deionized water 4 ml/min

An example of the present thermal FIA is shown in Fig.4. The height of output signal, which corresponds to the change in temperature before and after mixing HCl of different concentration with a NaOH solution of constant concentration (0.2 M in this case), was changed according to HCl concentration in the range of 0.003 to 0.2 M. The calibration curve obtained was not linear, but somewhat curved downward. This is probably due to a heat radiation to air, which may occur around the sensor. The detection limit estimated from the calibration curve was 0.002 M ($S/N=3$). The output signal was rather small in our detection system, but, the signal-to-noise ratio was also relatively small owing to that any mechanical pumping system was not employed and to that the pass-condenser and the integral circuit worked effectively. The pumping system is an important factor to detect such a small temperature change as a few to several hundreds of μC . A plunger-type pump, even though equipped with back-pressure coils and dumper tubes, could not be used because of its high mechanical noise.

At the optimum condition, a relative standard deviation for 20 sampling cycles of 0.05 M HCl was within 2.0 % and a sampling rate was 120 cycles/hr. Also, in the NaOH determination by HCl, similar results were obtained as shown in Fig.5.

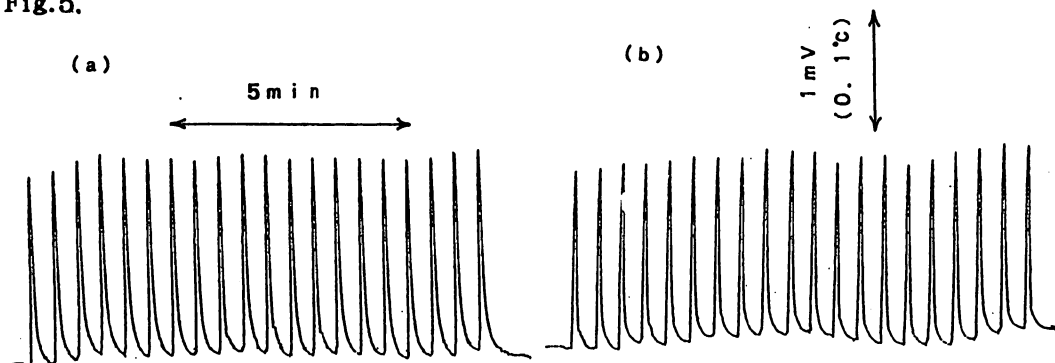

Fig. 5 Continuous sampling chart obtained by the reaction

- (a) 0.05 M HCl sample injection with 0.2 M NaOH reagent solution
- (b) 0.05 M NaOH sample injection with 0.2 M HCl reagent solution

Resistance (R) of thermistor as a function of temperature (T) is expressed as follows:

$$R = R_0 \exp B(1/T_0 - 1/T) \quad (1)$$

where, R_0 is resistance at the reference temperature T_0 and B is a constant. On the other hand, resistance of a metal resistor, the detector used in this work, is shown as follows:

$$R = R_0 \{1 + C (T - T_0)\} \quad (2)$$

where C is a TCR. We can see, from Eqs. 1 and 2, that thermistor is more sensitive to a temperature change and, therefore, also means that thermistor is liable to produce a relatively large output error, because the relation of temperature and resistance is not linear. We made a simulation on the assumption that an 0.2 °C change in a solution temperature occurs by a neutralization reaction, and R_0 and B (or C) values are completely same between SEN and REF. In this simulation we employed as R_0 , 10 kΩ for thermistor and 1 kΩ for resistor coil, 3500 as B, and 4400 ppm/°C as C; these are value of normal thermistor or the value of the resistor used in this work. Output errors thus simulated are shown in Fig. 6, from which we can see that a thermistor-type detector is affected more seriously by ambient temperature.

In general, thermistor is used in a tube directly dipped in an acidic or alkaline solution. In such circumstances, the detector is easily corroded moreover, the output signal tends to be affected by a flow

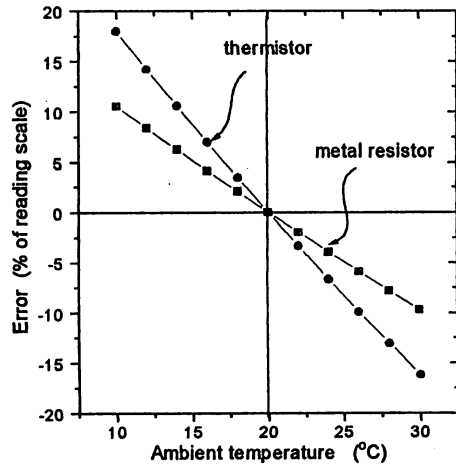

Fig.6 Comparison between metal resistor and thermistor

Simulation datas were calculated in follow conditions
 delta t : 0.2°C
 metal resistor : R_0 1kohm, TCR 4400ppm/°C,
 thermistor : R_0 10kohm, B 3500

confusion, or sample diffusion, because the dipped sensor measures temperature at the point in the flow, and the inner diameter of the tube is larger to include the thermistor. The resistor coil-type detector used in this work measures the mean temperature of the capillary, around which the thermo-sensitive resistance was coiled. When the detector is longer, it seems difficult to detect fast solution parameter change. But, this problem can be dissolved by increasing flow rate and decreasing diameter of the capillary. Also, a long detector has a better signal stability than dipping type that is easily affected by flow confusion. The inner diameter of the sensor could be designed smaller than that of thermistor. Consequently, the sample diffusion in the detector could be decreased to get a better sensitivity and a faster sampling rate.

An example of application of the present thermal FIA to the weak-acid and weak-base system is shown in Fig. 7. Acetic acid solutions of 0.01~0.2 M were successfully determined by an ammonia of 0.2 M. The peak heights were slightly lower than the data obtained in this acid determination by strong-base NaOH. The detection limit was 0.003 M.

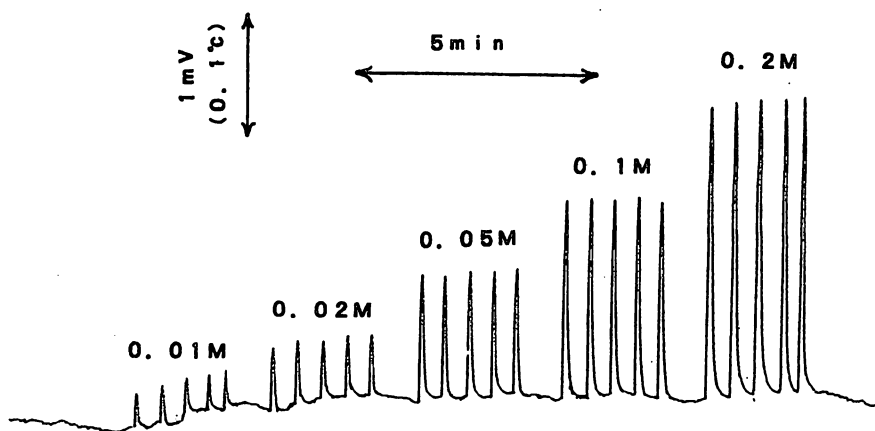

Fig. 7 Chart obtained in weak-acid and weak-base system

Sample : 0.01~0.2 M acetic acid, reagent : 0.2 M ammonia 1ml/min
 carrier : deionized water 4ml/min

It was found, using different acids of 0.1 M and a NaOH solution of a constant concentration (0.2 M), that the output signal per an unit acid concentration in M was nearly proportional to the neutralization energy,¹² derived under infinitely diluted conditions as shown in Fig.8. This means that when runs are made under identical conditions, the slope of calibration exhibits an inherent value characteristics of the type of acid to be determined.

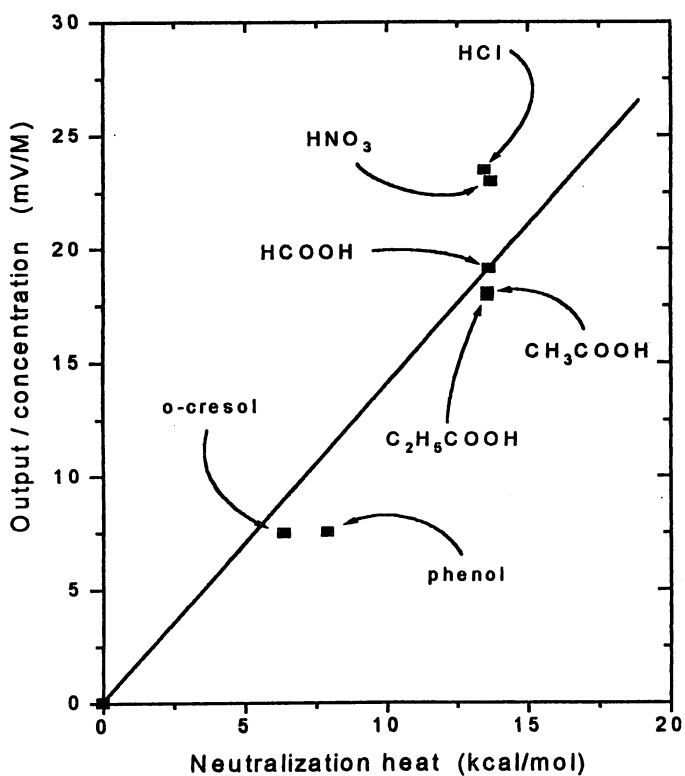

Fig. 8 Relationship between neutralization energy and output

Acids of 0.1 M were determined by 0.2 M NaOH

Conclusion

Rapid determinations of acid or base were demonstrated using thermal FIA system. The system can be easily produced for oneself. A wide application of the system is expected.

References

1. J. Toei, Y. Saigusa and N. Baba, *J. Flow Injection Anal.*, **3**, 27 (1986).
2. T. Imato and N. Ishibashi, *Anal. Sci.*, **1**, 481 (1985).
3. H. Linde, L. B. Rogers and D. N. Hume, *Anal. Chem.*, **25**, 404 (1953).
4. J. Jordan and T. G. Alleman, *Anal. Chem.*, **29**, 9 (1957).
5. J. Jordan and W. H. Dumbaugh, *Anal. Chem.*, **31**, 210 (1959).
6. B. C. Tyson, W. H. McCurdy and C. E. Bricker, *Anal. Chem.*, **33**, 1640 (1961).
7. W. E. Linden, M. Bos, H. H. Heskamp and H. Wilms, *Fresenius' Z. Anal. Chem.*, **329**, 440 (1987).
8. H. Berge and R. Lammert, *Chem. Techn.*, **40**, 305 (1988).
9. S. Fujieda and W. Zhang *Anal. Sci.*, **10**, 889 (1994).
10. I. Satoh, *J. Flow Injection Anal.*, **8**, 111 (1991).
11. R. S. Schifreen, *Chem. Anal.*, **79**, 97 (1985).
12. *Kagaku Binran*, Chemical Society of Japan, Maruzen, 1975, 979.

(和文要旨)

中和熱を利用した酸-塩基のフローインジェクション分析法を提唱する。注入された試料(酸または塩基)はキャリア(脱イオン水)によって流され、試薬(塩基または酸)と合流混合される。ミキシング直後の温度変化をステンレスチューブに巻いた感温抵抗体にて検出する。キャリアの温度を参照として用いた。0.003から0.2Mの塩酸溶液を120試料/時の速度で定量することが出来た。この方法を用いると弱酸-弱塩基の系でも分析が可能であった。感温抵抗体は腐食から完全に免れており、かつ環境温度の影響や検出部における試料の拡散が低減された。

(Received February 27, 1995)

(Accepted April 19, 1995)