

# Analysis of 3D Planar Crack Problems by Body Force Method

Md. A. Hasib<sup>1,a</sup> and A. Saimoto<sup>2,b</sup>

<sup>1</sup> Graduate Student, Department of Mechanical Engineering, Graduate School of Engineering, Nagasaki University, 1-14 Bunkyo-machi, Nagasaki 852-8521, Japan

<sup>2</sup> Corresponding Author: Graduate School of Engineering, Nagasaki University, Japan  
<sup>a</sup>ahasib73@gmail.com, <sup>b</sup>s-aki@nagasaki-u.ac.jp

**Keywords:** Body force doublet, Triangular crack element, Stress intensity factor, 3D Planar Crack.

**Abstract.** Derivation of the integral equation for general 3D crack problems was examined based on the theory of body force method. In the present analysis, stress intensity factors (SIFs) along a front of arbitrary shaped 3D planar crack are obtained directly only by solving simultaneous equations expressing a boundary condition. The crack surface is discretized using number of triangular elements and the variation of the force doublet embedded in each triangle is assumed at constant. The derived boundary integral equation was transformed into a set of simultaneous equations and was solved computationally. In order to improve the accuracy of the numerically examined boundary integral, a polar transformation scheme combined with Taylor expansion of the fundamental solutions is introduced. Not only a single crack problem but also an interference among coplanar cracks can be calculated using the unique program developed in this research. It was verified that as the number of triangular elements increases, the evaluated SIF converges to the reference solution.

## Introduction

SIF determination plays a central role in linear elastic fracture mechanics. Since SIF was proposed by Irwin [1] to express displacements and stresses in the vicinity of crack tip, several analytical techniques have been developed for a variety of common crack configurations; however, these analytical solutions are limited to simple crack geometries and loading conditions. Advances in numerical modeling procedures have opened new doors for fracture mechanics analysis. Advanced researches have been carried out based on FEM, BEM and other numerical techniques but may be undesirable due to excessive modeling and computational time. Nisitani [2] first applied the body force method (BFM) to crack problems. The BFM has been provided highly accurate solutions of stress concentration factors and SIFs of practically important problems, but the treated 3D problems are considerably limited than 2D problems till now. Isida and Tsuru [3] proposed a new technique for 3D crack analysis based on BFM. Noda [4] discussed numerical solutions using singular integral equation of the BFM for 2D and 3D cracks problems. However, these solutions are limited to crack geometries and also need to solve equations for each problem. In the present research, a numerical program based on BFM for versatile purpose has been developed. And is used to analyze a various 3D planar crack problems.

Crack to crack interaction can change the stress distribution near the macro crack tip. Thus the study of interacting cracks subjected to a given set of external load is extremely important for the purpose of design and life prediction of mechanical structures. Till now interaction between cavity problems was solved based on BFM [5]. In the present paper, the interference effect between different-shaped planar cracks is also presented.

## Theoretical analysis

In BFM, the solution of any elastic problem is transformed into a problem of a complete infinite domain without any crack nor notch. That is, a boundary of a given problem is replaced by an equivalent imaginary boundary along which body forces and body force doublets are embedded [6].

Consider an arbitrary oriented planar cracks of general shape in an infinite solid. Take the global coordinate system  $O$ - $XYZ$  and local coordinate system  $O'$ - $xyz$  of the crack as shown in Fig. 1a. For the analysis of the crack, the global coordinate is transformed to local coordinate system where  $z$ -axis is normal to the crack surface. On the idea of the body force method, the problem is reduced to sets of integral equations in which the density of force doublets are unknowns to be determined.

Let  $\sigma_{zz}$ ,  $\tau_{zx}$  and  $\tau_{yz}$  be the stress component in local coordinate system due to the fundamental force doublets distributed over the crack surface. The stress component in local coordinate system are as follows.

$$\sigma_{zz}(P) = \sigma_{zz}^{\infty}(P) + \iint_{\Omega_c} [\sigma_{zz}^{zz}(P, Q)\gamma_{zz}(Q) + \sigma_{zz}^{zx}(P, Q)\gamma_{zx}(Q) + \sigma_{zz}^{yz}(P, Q)\gamma_{yz}(Q)] d\Omega_c(Q) \quad (1)$$

$$\tau_{zx}(P) = \tau_{zx}^{\infty}(P) + \iint_{\Omega_c} [\tau_{zx}^{zz}(P, Q)\gamma_{zz}(Q) + \tau_{zx}^{zx}(P, Q)\gamma_{zx}(Q) + \tau_{zx}^{yz}(P, Q)\gamma_{yz}(Q)] d\Omega_c(Q) \quad (2)$$

$$\tau_{yz}(P) = \tau_{yz}^{\infty}(P) + \iint_{\Omega_c} [\tau_{yz}^{zz}(P, Q)\gamma_{zz}(Q) + \tau_{yz}^{zx}(P, Q)\gamma_{zx}(Q) + \tau_{yz}^{yz}(P, Q)\gamma_{yz}(Q)] d\Omega_c(Q) \quad (3)$$

In these equations,  $P(x, y, z)$  is a reference point,  $Q(\xi, \eta, \zeta)$  is a source point,  $\Omega_c$  is an imaginary crack surface,  $\gamma_{zz}$ ,  $\gamma_{zx}$  and  $\gamma_{yz}$  are the unknown functions called density of standard force doublets. These equation includes nine fundamental solutions which can be derived from the Kelvin solution (a stress field due to a point force acting in an infinite solid). Among the fundamental solutions of body force doublet, three of them are listed below as an example and similarly it is possible to derive the others solutions.

$$\sigma_{zz}^{zz}(P, Q) = \frac{1 - 2\nu}{8\pi(1 - \nu)^2} \left[ \frac{1}{r^3} + 6 \frac{(z - \zeta)^2}{r^5} - 15 \frac{(z - \zeta)^4}{r^7} \right] \quad (4)$$

$$\tau_{zx}^{zz}(P, Q) = \frac{3(1 - 2\nu)}{8\pi(1 - \nu)^2} (x - \xi)(z - \zeta) \left[ \frac{1}{r^5} - 5 \frac{(z - \zeta)^2}{r^7} \right] \quad (5)$$

$$\tau_{yz}^{zz}(P, Q) = \frac{3(1 - 2\nu)}{8\pi(1 - \nu)^2} (y - \eta)(z - \zeta) \left[ \frac{1}{r^5} - 5 \frac{(z - \zeta)^2}{r^7} \right] \quad (6)$$

Where  $r^2 = (x - \xi)^2 + (y - \eta)^2 + (z - \zeta)^2$  and  $\nu$  is the Poisson's ratio.

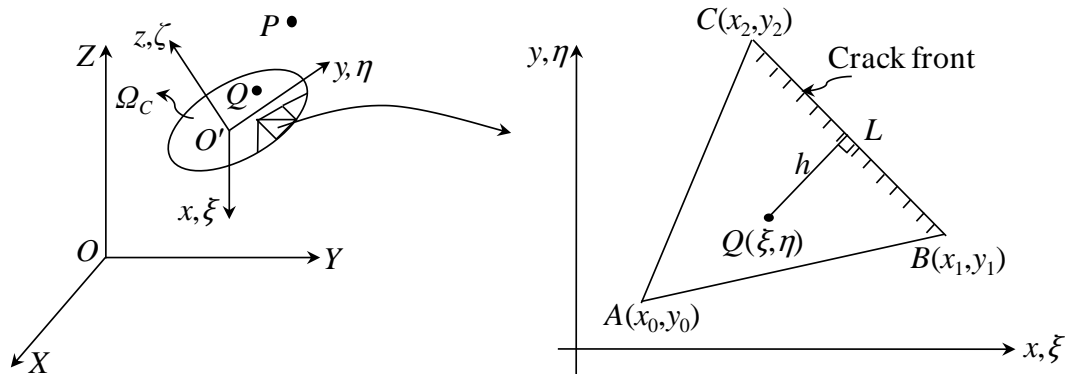

Fig. 1: a) Global and local coordinates systems; b) Planar triangle surface element

In this analysis the surface of the crack is expressed by the aggregation of planar triangles and in each triangle the density of the force doublets is assumed at constant. The triangles placed at the crack front, the basic density function is considered as shown in Fig. 1b. Density of standard force doublets  $\gamma_{zz}$ ,  $\gamma_{zx}$  and  $\gamma_{yz}$  are expressed by the product of basic density function  $\sqrt{h(\xi, \eta)}$  and weight functions  $W_{zz}(\xi, \eta)$ ,  $W_{zx}(\xi, \eta)$  and  $W_{yz}(\xi, \eta)$  respectively.

$$h(\xi, \eta) = \frac{|x_2 y_1 - y_2 x_1 + (y_2 - y_1)\xi + (x_1 - x_2)\eta|}{\sqrt{(y_2 - y_1)^2 + (x_2 - x_1)^2}} \quad (7)$$

$$\gamma_{zz}(Q) = \sqrt{h(\xi, \eta)} W_{zz}(\xi, \eta) \quad (8)$$

$$\gamma_{zx}(Q) = \sqrt{h(\xi, \eta)} W_{zx}(\xi, \eta) \quad (9)$$

$$\gamma_{yz}(Q) = \sqrt{h(\xi, \eta)} W_{yz}(\xi, \eta) \quad (10)$$

When the crack surface is free of traction,  $\sigma_{zz}$ ,  $\tau_{zx}$  and  $\tau_{yz}$  are zero at the same time when the reference point  $P$  approaches to a point  $P^\Omega$  which is fixed on the crack surface. After solving the simultaneous equations so that the boundary condition is satisfied, the value of weight functions are computed. The mode-I SIF  $K_I$  at crack front is evaluated from the value of  $W_{zz}(\xi, \eta)$ . While  $W_{zx}(\xi, \eta)$  and  $W_{yz}(\xi, \eta)$  are responsible for the values of  $K_{II}$  and  $K_{III}$ . Taylor's expansion with polar transformation has been applied for the sake of numerical accuracy.

## Numerical Example and Discussion

The integral equation derived is applicable to arbitrary oriented planar cracks. In order to verify the applicability of the present method, SIF calculation for penny-shaped, elliptical and rectangular cracks were examined. In each analysis, the surface of the corresponding crack was divided with regularly distributed triangular elements. It was found from numerical analysis that the obtained SIF solution tend to converge to an ideal value with mesh refinement and its tendency was almost reciprocal to the total number of triangular elements.

Fig.2a shows distribution of normalized stress  $\sigma_{zz}$  along  $x$ -axis when uniform tensile stress into the  $z$  direction is applied to an infinite solid with elliptical crack. The result was computed with 400 triangular elements. As the length ratio between minor and major axis of ellipse increases the stress distribution increases gradually.

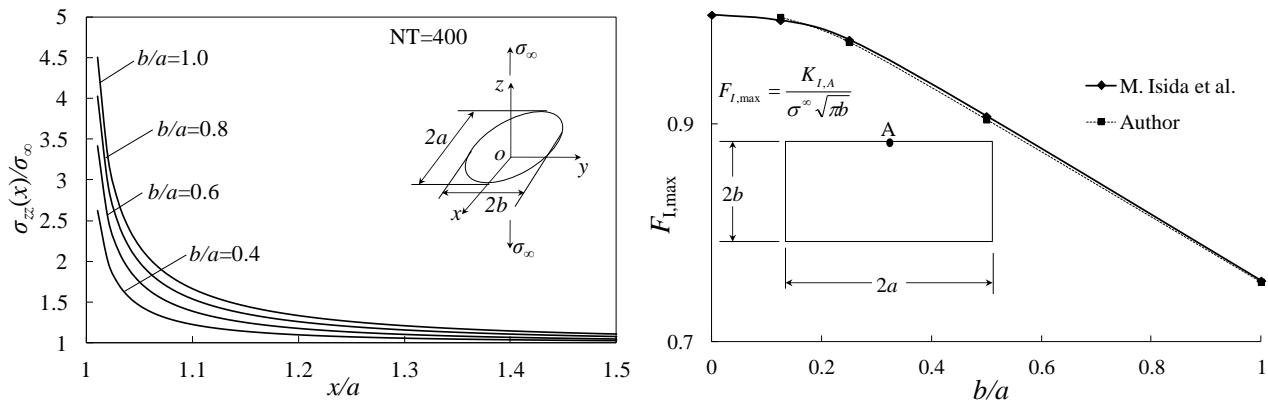

Fig.2: a)  $\sigma_{zz}$  distribution along  $x$ -axis

b) Maximum SIF of a rectangular crack.

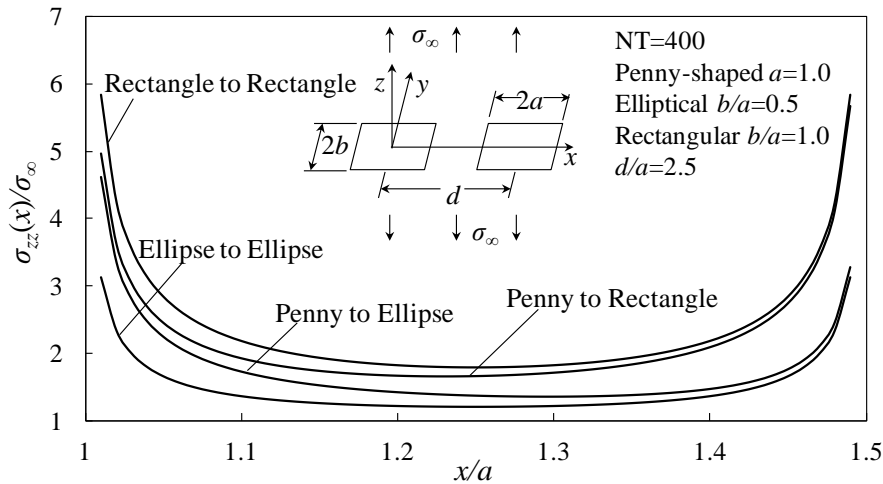

Fig. 3:  $\sigma_{zz}$  distribution between various shaped planar cracks ( $d/a=2.5$ ).

Fig. 2b shows dimensionless maximum SIF variation of rectangular crack. The results from the present method are in good agreement with the results in the literature [3]. The interference effects between penny-shaped, elliptical and rectangular cracks are also analyzed. Fig.3 shows the interference effect between different shaped cracks with fixed distance. The number of triangular elements for each crack was fixed at 400. Among compared, the rectangle to rectangle crack combination showed the largest interference effect.

## Conclusion

Versatile numerical program are necessary for the analysis of SIF evaluation of 3D cracks because analytical solutions are limited to simple geometry and it is also difficult to develop a special program for each problem. In this research the 3D crack problem was formulated in terms of singular integral equation with singularity of the form  $r^{-3}$  on the basis of body force method, where force doublets were used to express the presence of crack. Any arbitrary shaped planar crack can be solved from the developed mathematical technique. Any kinds of 3D planar cracks can be solved effectively only by providing an input data. Accurate and fast evaluation of the SIF for penny-shaped, rectangular and elliptical cracks shows the proposed procedure is robust for SIF and stress calculation. A constant element of triangular shape is simple and easy to handle for planar crack problems, however, some difficulty arises when the distribution of stress intensity factor along crack front is computed. Therefore, a higher order element as in quadratic triangular element would be better to introduce for further development.

## References

- [1] Irwin, G. R. Trans. ASME, J. of Applied Mech., 24: pp.361-364 (1957)
- [2] H. Nisitani and Y. Murakami, Int. J. Fract., 10: pp.353-368 (1974)
- [3] M. Isida, H. Tsuru and H. Noguchi, Int. J. Frac., 52: pp.79-90 (1991)
- [4] Q. Wang, N.A. Noda, M.A. Honda and M. Chen, Int. J. Fract., 108: pp.119-131 (2001)
- [5] Md. A. Hasib, A. Saimoto, Proc. JSSUME, pp.47-50 (2012)
- [6] H. Nisitani, J. of Japan Soc. Mech. Engrs., Vol. 70, pp.627-635, (1967) (in Japanese)