

630.7

il6c

no.1033

1971

UNIVERSITY OF
ILLINOIS LIBRARY
AT URBANA-CHAMPAIGN
ACES

630.7
ilbc
no. 1033
Rev 1971

UNIVERSITY OF ILLINOIS
AGRICULTURE LIBRARY

**PRUNING
EVERGREENS
AND
DECIDUOUS
TREES AND
SHRUBS**

AGRICULTURE LIBRARY

AUG 26 1988

UNIVERSITY OF ILLINOIS

UNIVERSITY OF ILLINOIS AT URBANA-CHAMPAIGN / COLLEGE OF
AGRICULTURE / COOPERATIVE EXTENSION SERVICE / CIRCULAR 1033

PRUNING EVERGREENS	3
Arborvitae	3
Junipers	4
Yews	7
Pines	9
Spruce	11
Firs	12
Pruning Broadleaf Evergreens	13
Pruning Evergreen Hedges	13
General Information	14
PRUNING DECIDUOUS TREES AND SHRUBS	15
Renewal Pruning	15
Heading Back	16
Rejuvenation	17
Plants That Winter Kill	20
Pruning Deciduous Hedges	20
Pruning Multi-Stem Trees	22
Pruning Vines	25
Pruning Clematis	26
Pruning Young Shade Trees	27
Pruning Large Trees	30
Pruning Roses	37
Pruning Rhododendrons, Including Azaleas	40
Pruning Hydrangeas	41
General Information	41
INSECT CONTROL	44
HOW TO PRUNE COMMON SHRUBS	45
TREES GROUPED ACCORDING TO USE	55

A pruning slide set and script are available for use in Illinois in conjunction with this circular. To obtain the slides, contact your local Extension adviser.

This publication was written by F. A. Giles, Extension specialist in horticulture, and W. B. Siefert, area Extension adviser in ornamental horticulture (Edwardsville). Artwork was prepared by F. A. Giles. The authors express appreciation for review of the manuscript to J. B. Gartner, professor of ornamental horticulture; M. M. Meyer, assistant professor of nursery management; and M. C. Carbonneau, Extension specialist in floriculture.

Pruning and Care of Evergreens and Deciduous Trees and Shrubs

One objective of pruning trees and shrubs around the home should be to maintain a good size relationship or scale between the home and its plantings. Another objective of pruning is to maintain the natural beauty of the plant and keep it as strong as possible. Other reasons for pruning are to correct damage, improve flowering, or remove diseased portions. Incorrect pruning can leave a plant weak and susceptible to disease and insect damage. Poor pruning practices can also cause flower or fruit loss.

The old idea of formalized pruning is steadily giving way to maintaining the natural habit or shape of the tree or shrub. Plants that have been given a “butch hair cut” or cubed, balled, or pillared become man-made ornaments and do not serve as plant material or resemble living plants in their natural state. If these shapes are desired, choose a plant that grows naturally in that form. Keep the plant’s mature size in mind.

The hazard of formalized pruning is that once begun it cannot be easily changed. Formalized pruning should be used where plant material forms an architectural function, as when a hedge serves as a fence or a porch rail. There are plants that lend themselves to this type of pruning better than others. If you intend to shear plants into a hedge, select the best plant for that purpose, such as Hicks yew or buckthorn.

Pruning is the removal or reduction of certain plant parts that are not required, or no longer effective, or injurious to the plant. Pruning is done to supply additional energy for the development of such plant parts as flowers, fruit, and limbs that shape the plant.

The following pages will explain and illustrate the correct methods of pruning to maintain the natural shape and beauty of your landscape plants.

Good design and proper planting will reduce pruning problems. If you have not yet planted your shrubbery or if you intend to add more later, the illustrations should be of assistance. Simply because plants are attractive and in scale with the house the day they are planted does not mean they will stay in scale.

Plants do grow, and more rapidly than we realize. To avoid early

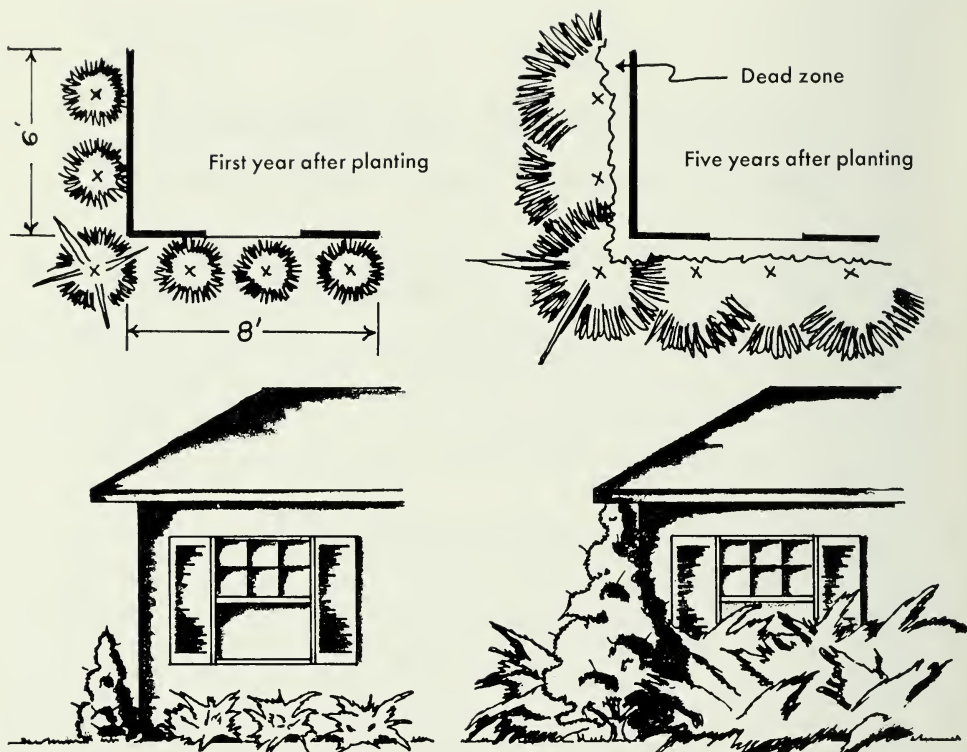

The drawings on the left show plants spaced 2 feet from the foundation and 3 to 4 feet apart. The drawings on the right show the same planting at maturity. This is a poorly planned corner planting arrangement because the plants are too close to the house and to each other. (Fig. 1)

overgrown conditions (Fig. 1), it is always advisable to know the mature size of the plants being used in the landscape (see section on plant descriptions and pruning instructions on page 45). Good design can extend the life of a plant far longer than one would expect.

The corner planting indicated in Figure 2 has enough room to grow and develop naturally. Careful selection of plants based on their mature size and proper spacing will eliminate maintenance for many years and produce an attractive landscape scene. Ground covers and a heavy mulch will eliminate most weeds until the shrubbery matures.

If you want more information on home landscaping, you may obtain Illinois Extension Circular 858, "Landscaping Your Home," by sending \$2.00 to the Office of Agricultural Publications, 123 Mumford Hall, Urbana, Illinois 61801. The circular has 151 pages and is well illustrated.

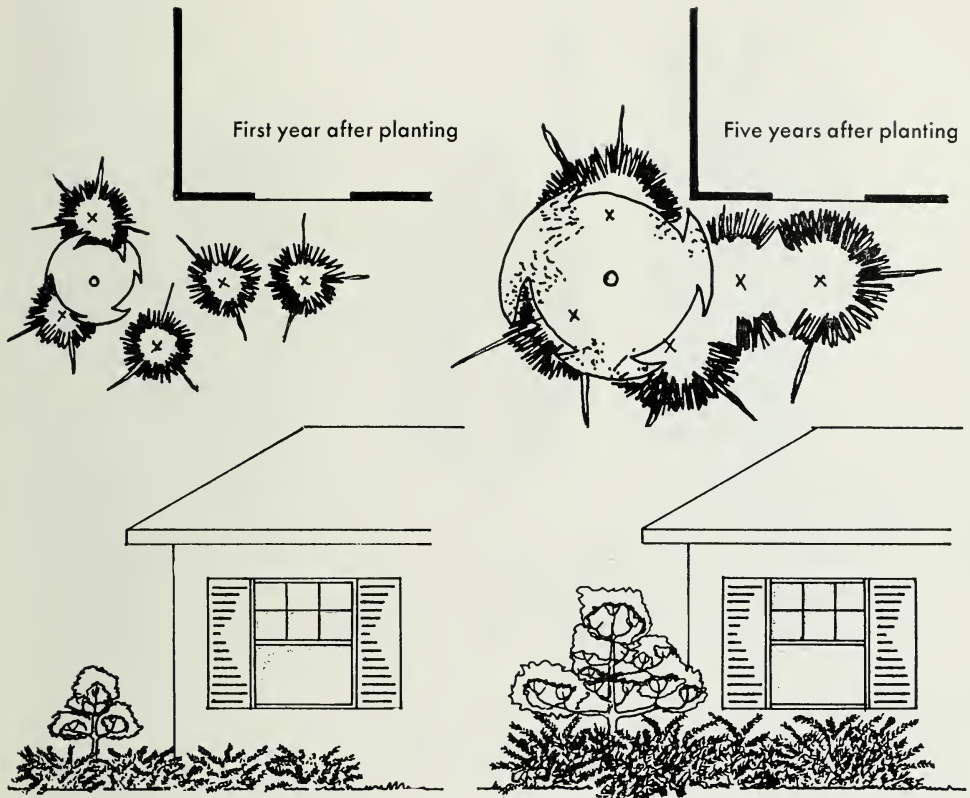

The drawings on the left show a properly planned corner planting. Evergreens are planted 4 to 5 feet from the foundation and 4 to 5 feet apart. Mature size would determine spacing of deciduous plants. The same planting five years later is shown in the drawings on the right. (Fig. 2)

Pruning Evergreens

Arborvitae (*Thuja*)

Arborvitae (Fig. 3) can be pruned to remove a large portion of the foliage and still get satisfactory recovery because new branches develop from concealed buds in the crotches.

Pruning of all arborvitae (columnar, globe, and intermediates) should include removing the tip portion back to a satisfactory branch. When heavy corrective pruning is necessary the best time is mid-March through early April when new growth will quickly hide the cut surfaces and exposed inner branches.



Typical forms of arborvitae fronds:
side fronds (left) and end frond
(right). (Fig. 3)

American arborvitae. Its pyramidal forms can be easily maintained at any height by repeated pruning with hand pruning shears.

The top normally can be reduced 20 percent or more by lopping off at a crotch, then reshaping by pruning the lower limbs to produce a natural effect. (Fig. 4). If more than 20 percent must be removed to bring the plant in balance with the home and surrounding plants, be certain this lopping cut is above the dead zone. When most of the green growth is removed during pruning be prepared to wait a year or more for complete recovery or consider removal and replanting.

Sides are easily pruned by cutting off tips to a vigorous side branch (Fig. 4).

The dead zone develops when older plants lose their needles in the center because of heavy shade. New growth will not develop from this area unless there are surviving green twigs and needles. When severe pruning allows sunshine to reach the dead zone occasional new shoots will occur along the edge, but most of the dead zone is unable to respond.

Where heavy corrective pruning is necessary, the best time is before new growth appears in mid-March through early April.

Oriental arborvitae. These are slow-growing, dense, and extremely symmetrical. They rarely need pruning, but when necessary hedge shears seem the best choice of equipment. These plants cannot be pruned very satisfactorily.

Junipers (*Juniperus*)

This is a varied group of plants that includes spreading, upright, pyramidal, and creeping types.

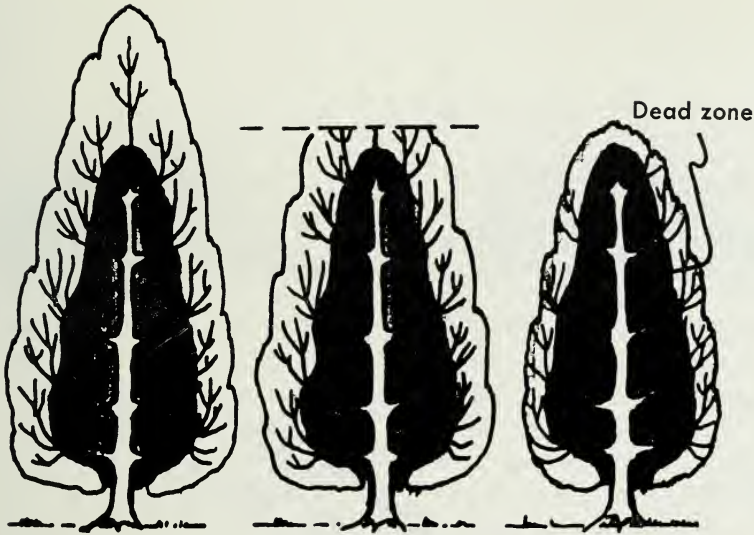

Pruning procedures for pyramidal evergreens. Left, before pruning; center, 20 percent of top removed; and right, sides pruned to restore shape. Dead zone in center is shaded. (Fig. 4)

Spreading junipers (pfitzers). Routine pruning of spreading junipers requires annual pruning of dominant branches to promote uniform growth. During early spring, prune dominant branches by cutting at the junction of a lateral (side) branch (Fig. 5). Several vigorous lateral branches develop from each dominant limb, so you have to decide how much must be removed to produce a harmonious appearance. Do not overlook the possibility that an entire branch should be removed.

When severe pruning is necessary to reduce the size or prevent overlapping growth of spreading junipers, some major cuts are necessary. Complete removal of the top limb (Fig. 5), will accomplish this. Prune side limbs to create better balance. Some exposure of the dead zone is expected. When some green foliage remains on top the plant will survive and the remaining green limbs will soon cover the exposed dead zone with new growth. Mid-April is an ideal time to prune because new growth will quickly restore natural beauty and there will be less chance of sunburn of exposed limbs.

Semi-upright junipers (hetzi). The routine pruning of upright junipers is the same as for spreading junipers.

Severe pruning requires cutting back main limbs to a vigorous lateral branch. If major cuts are necessary, be careful to locate the dead zone first

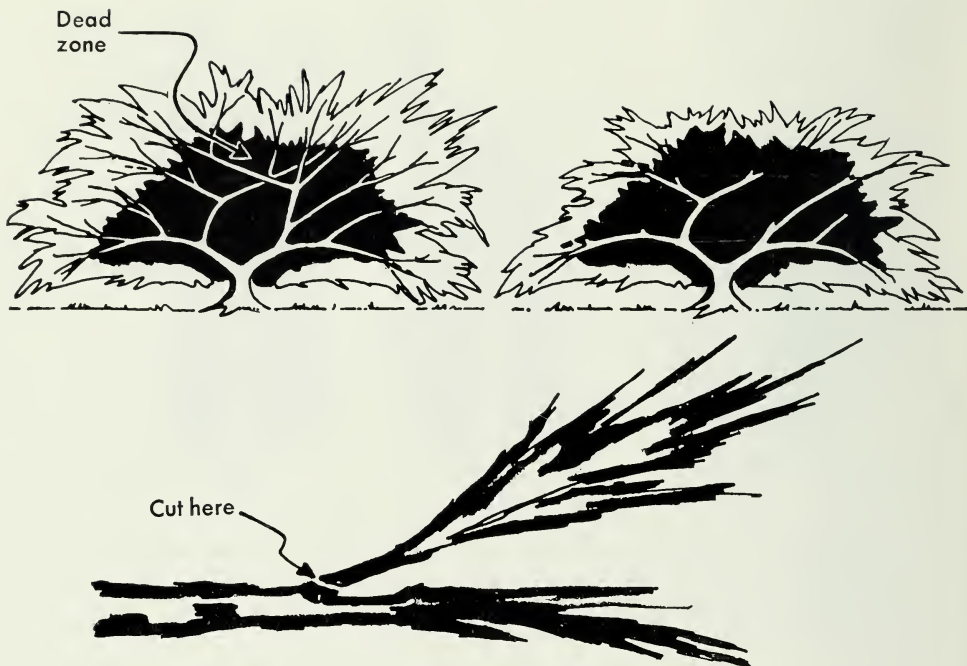

The two shrubs above indicate where cuts should be made to reduce the size or reduce overlapping of spreading junipers. The bottom drawing shows where to make a cut on an individual branch. (Fig. 5)

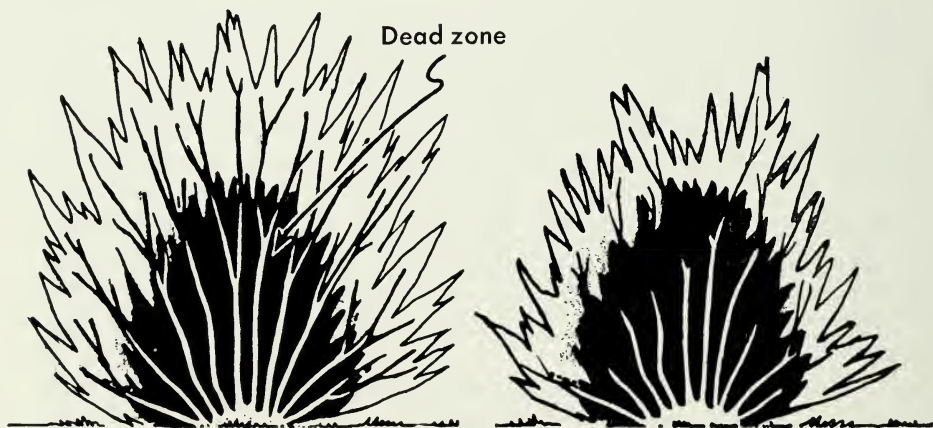

These drawings show where cuts can be made when pruning upright junipers. The drawing on the right shows the plant with natural shape maintained after pruning reduced size. (Fig. 6)

and leave some green twigs on every cut limb. Prune side limbs lightly (Fig. 6).

Pyramidal junipers. Maintenance pruning of pyramidal junipers involves occasional pruning back (not shearing) of dominant branches and the leader (top branch) to maintain uniform growth and natural beauty. If plants have been heavily sheared there is little hope of restoring their natural character. Replanting and good care will produce more satisfaction than several seasons of pruning sheared plants to restore their natural beauty.

Excessive height can be reduced by 20 percent or more by lopping off the top of the plant (Fig. 4). The lopping cut must be above the dead zone to insure development of a new leader. Reshape the sides by pruning all the limbs to restore their natural shape. As long as some of the side foliage remains, the plant will survive. Close cuts at crotches will not produce dead stubs. Severely prune in April when new growth will quickly restore natural beauty and conceal the stiff skeleton of the plant.

Creeping junipers (andorra). Creeping junipers are pruned to keep them within bounds by using the same procedures employed in maintenance pruning of spreading junipers. Cut back protruding limbs to a vigorous lateral branch and never leave stubs.

Severe pruning requires removal of many center branches to reduce the "mound" of growth. Crossing limbs should be removed until only radiating limbs remain. Protruding outside limbs can then be pruned to a vigorous side branch. Scattered green twigs over the center of the crown will quickly conceal the exposed crown and restore natural beauty. Major pruning should be done in mid-April.

The dead zone. All junipers develop a dead zone in the center because of insufficient light to the inside limbs. New growth will not develop from this area unless there are surviving green twigs and needles. When severe pruning allows sunshine to reach the dead zone, occasional new shoots will occur along the edge, but most of the dead zone is unable to respond.

Yews (*Taxus*)

This group of plants is valuable because of slow growth, wide adaptability, extreme shade tolerance, and ease of pruning (Fig. 7).

Dwarf Japanese yews and similar forms are slow growing. Occasional pruning is useful to maintain size and natural beauty.

Spreading yews and similar forms are vigorous growers and will

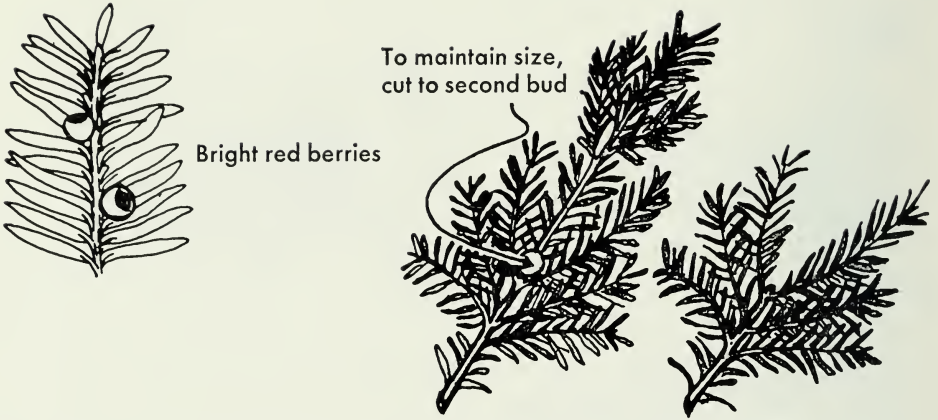

Typical shoots of yew shrubs. Note the berries (bright red) on the shoot at left. (Fig. 7)

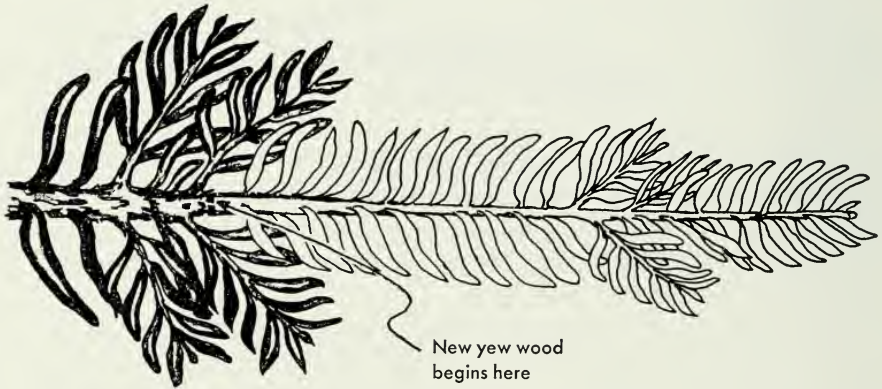

New yew wood is bright yellow-green and cuts quite easily. (Fig. 8)

Angle cut at cluster of twigs on a large limb. (Fig. 9)

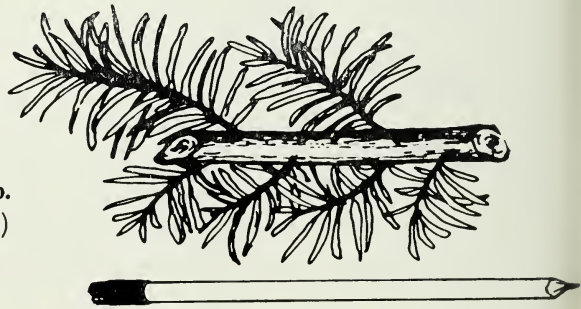

eventually become very large plants. When yews are growing well, pruning every spring and again in mid-June is necessary to maintain shape and compactness. When severe cutting back is necessary to reduce their size, they may be cut back as much as 50 percent and still make a strong recovery. Often they are cut back to the end of two-year wood by selecting a cluster of side branches as the pruning point.

New growth is easily distinguished from the old by its color. The new growth is bright yellow-green and cuts quite easily. The second-year and older wood turns brown and scaly (Fig. 8). In healthy plants the new growth will be from 6 to 18 inches long depending on the cultural practices used and on the season.

Upright yews and similar forms with a central leader only need to be pruned to thicken the plant and prevent excessive growth. Where multiple leader plants occur, pruning every season is necessary to maintain a compact and tidy appearance.

General procedure. Cut back the current season's growth to a cluster of side branches (Fig. 9). Make angle cuts whenever possible. These cuts may be made in late March and again in mid-June.

Heavy pruning. Cut back to the end of two-year wood. Make close cuts at a crotch or among a cluster of side branches. These openings will permit sunshine to stimulate growth of inside twigs and dormant buds. (Fig. 11).

Severe pruning. Severe cutting to 50 percent is possible because small green twigs and dormant buds occur throughout the plant. Make angle cuts among these bud and twig clusters (Fig. 8) or close cuts at crotches. Every remaining twig or stub should have green growth or visible dormant buds. Severely prune in mid-April or late April when new growth will quickly shade the large limbs and prevent sunburn.

Pines (*Pinus*)

Austrian, red, scotch, white, and mugho pines. Prune during the middle or late part of June. Normal shoot buds are produced only on the tips of the branches. However, a dormant undeveloped bud exists in each needle bundle (Fig. 9). If the end of the shoot is cut off, or destroyed accidentally, new buds develop in the needle bundles nearest to the tip of the stub. But these needle bundle buds will not develop until July, and will not produce new shoots until the year following.

White, Austrian, red, and scotch pines. To produce a compact uniform plant the leader (candle) should be cut back to an 8- to 12-inch stub (Fig. 10). Prune the lateral (side) candles of this top cluster 2 to 4 inches shorter than the leader.

All the lateral branches must be pruned to maintain a pleasing shape and achieve the thick compact appearance so desirable for the home landscape (Fig. 12). For side branches use the same plan as the top, but cut back the main candles one-third to one-half instead of 8 to 12 inches. Cut the lateral candles slightly shorter.

When pines are out of bounds, usually little can be done except to remove them. Leaders and branch terminals can be cut back three-quarters of the way into two-year wood, but shock is severe. Every stub must contain several clusters of healthy needles or it will die. If done in June a few buds will develop in the surviving needle bundles and develop new shoots the following spring. Cutting into two-year wood should be attempted only as an emergency measure.

Mugho pines are often grown as a globe in the foundation planting. To develop a natural appearance, prune occasional shoots to maintain shape. To create a compact globe, prune all outside candles to 3- to 6-inch stubs. Severe pruning can reduce the size of large plants. Mid-June pruning to remove individual limbs to a crotch will be successful. Sunlight will

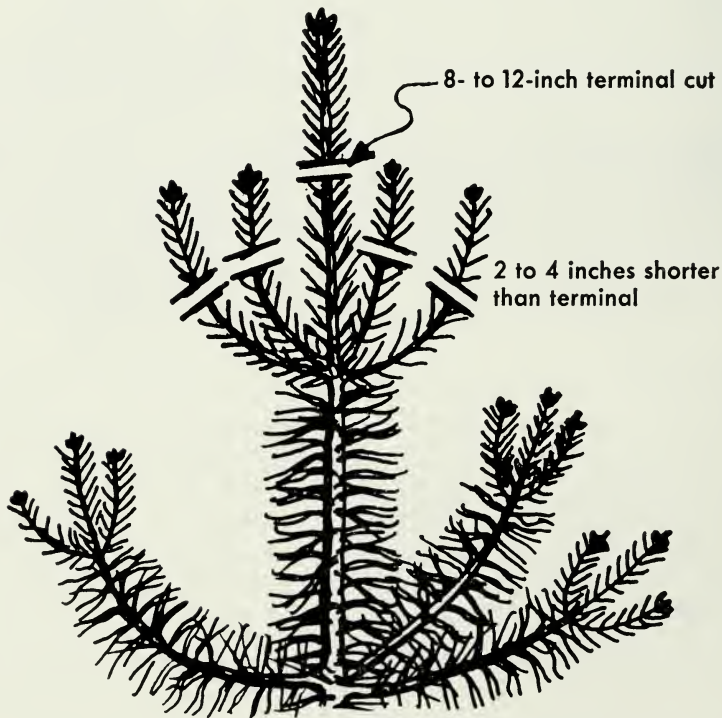

Prune pines in this manner to maintain a pleasing shape and thick, compact appearance. (Fig. 10)

Dormant undeveloped bud here



Pine needle bundle.

(Fig. 11)

stimulate some inside limbs to fill the resulting "holes" in the plant. After major pruning cut all outside candles to 3- to 6-inch stubs to produce the desired shape.

Spruce, Including Blue Spruce (*Picea*)

Both spruce and fir trees respond well to pruning. There is little hope of greatly reducing the size of an existing tree. Annual pruning in early July will develop a dense plant and slow the rate of growth.

Annual pruning. The leader (top) should be cut, leaving at least three buds on the remaining stub. Lateral shoots must be 1 to 2 inches

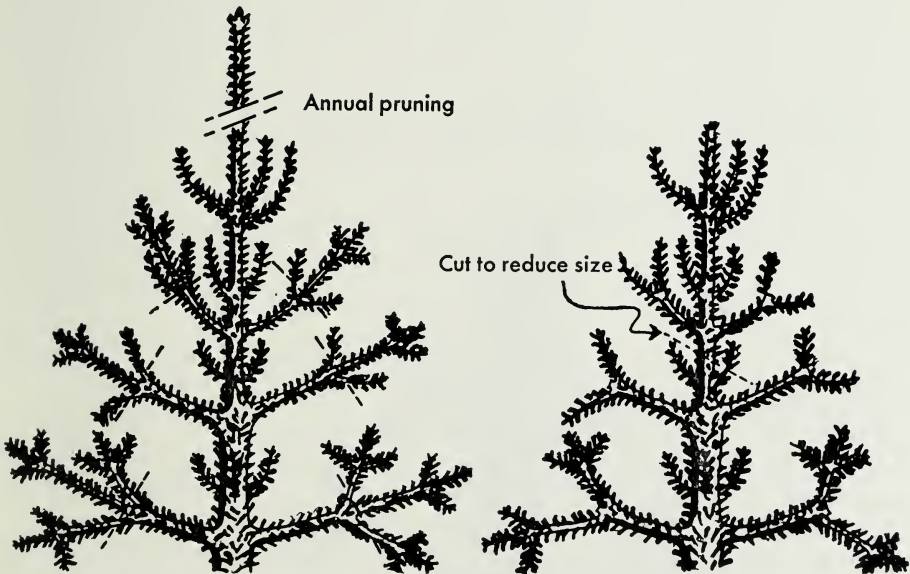

On the left is a spruce or fir with broken lines indicating where cuts should be made for annual pruning. On the right is the same plant after pruning, but with a broken line indicating where the branch could be cut to reduce its size. (Fig. 12)

shorter than the tip. If two or more leaders occur, remove all but one, then prune as directed. Prune all side limbs using the same formula.

Severe pruning. To reduce the size of the tree cut back the top into two-year wood. Leave 2 or 3 lateral shoots on the stub. Train a new leader by using one of the laterals and a splint of some sort. The first whorl of branches below the cut should be pruned using the same formula. Lower limbs should be cut back by pruning off the entire first- and second-year growth to the crotch.

Koster, Moerheim, and other asexually propagated spruce tend to lose their leader or main growing point. This inherited ailment makes the tip of the tree seem as if it is being blown horizontally by the wind. The leader or growing point can be replaced by splinting a new leader from a side branch as illustrated in Figure 13.

Fir (*Abies*) and Douglas Fir (*Pseudotsuga*)

Firs can be cut back more severely than spruce. Because needles are usually found on three- or four-year growth on firs it is safe to cut back into three-year wood. Leave at least two branches on the stub.

A new leader. Choose the nearest side shoot to the stub and tie it up with a splint (Fig. 13). Take care not to break the side shoot. Once this side shoot is tied in an upright position, prune all side branches to prevent a flat top.

Pruning evergreen hedges. Evergreen hedges should be pruned in the same manner as the deciduous plants described on page 20. It is very

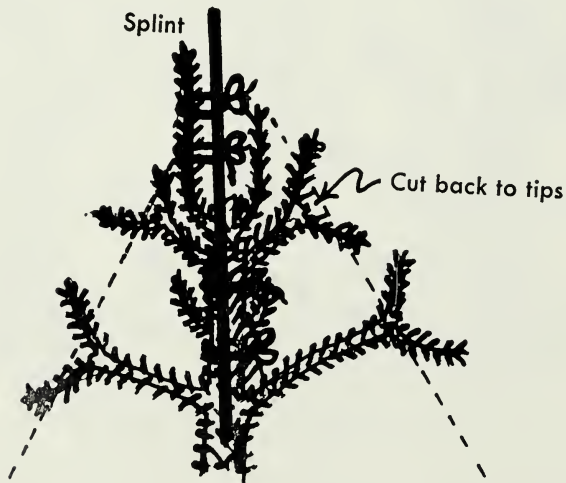

Creating a new leader.

(Fig. 13)

important to allow the plant to gradually grow larger. Never prune back to the same cut each time. Leave a small amount of new growth to give the hedge a greener, more attractive appearance as well as to leave a leaf surface for the manufacture of plant nutrients. If one removes all of this new growth, the plant is very susceptible to winter injury, disease, and sunburn. One-half inch of new growth covering the entire hedge is satisfactory.

It is good to fertilize evergreen hedges after pruning to maintain a healthy plant that will recover rapidly from the shock of shearing. Fertilizer recommendations vary as to species and age, but generally a 10-10-10 or 10-6-4 fertilizer can be applied to the surface of the soil at a rate of one cup per four feet of hedge. (See page 14 for a discussion of fertilizers.)

Pruning Broadleaf Evergreens

Broadleaf evergreens should be pruned very little if the plant is to be used as a specimen or focal point, the most common use. Broadleaf evergreens should be pruned to correct injury or to shape a strong plant, however. This procedure has been described for deciduous plants on page 40. Azaleas (*Rhododendron*), holly (*Ilex* sp.), and boxwood (*Buxus* sp.) are examples of plants that are best pruned very little and used as specimen plants. Light heading back is the best method to use.

There are two exceptions to this, one being where broadleaf evergreens are used as formal hedges. In this case, the plants should be pruned as described below. The other exception is with shrubs that tend to get tall and leggy or unsightly at the base, such as leather leaf viburnum (*Viburnum rhytidophyllum*) and Oregon holly grape (*Mahonia aquafolium*). Prune these plants as described for lilacs. Cut old wood out to the ground if the plant is multi-stemmed or back to the frame if single-stemmed.

Pruning Evergreen Hedges

Evergreen hedges should be shaped the same as deciduous hedges (Figs. 19 to 21). When shearing needle evergreen hedges, always wait until the new spring growth has hardened or matured, usually about the first week in June. Pruning at this time minimizes shock to the plant. Usually plants like the Hicks yew (*Taxus media* *Hicksii*) send up some new growth during cool periods in summer. This growth can be removed in late September to leave a hedge with a neat appearance all winter.

Broadleaf evergreens damage more easily than any other hedge plantings, especially in northern areas where these plants become marginal because of a lack of hardiness. Prune broadleaf evergreen hedges later than other hedges (late June), and leave more new growth than for deciduous and needle evergreen hedges. Over one-half inch is recommended and 1

inch is ideal for the health of the plant. Vigorously growing plants, such as the common boxwood or Korean boxwood (*Buxus* var.), can be cleaned up in September also, but remove only new growth. Do not cut into the foliage left after the June pruning. Slower growing hedges such as the convex leaf holly (*Ilex crenata* var.) should be pruned only once a year in late June.

General Information

Date of pruning. Late March or early April or early July have consistently proven most satisfactory for pruning to avoid a spring flush of growth. Mid-winter pruning often results in freeze back of the cut stub causing loss of additional branches near each cut stub. Every plant tends to look pruned after the pruning. With new growth appearing in late April, your efforts are soon concealed.

Spruce and fir may satisfactorily be pruned in late June or in late March without injury to the plant. Arborvitae, yews, and junipers usually are pruned again in early July to prevent the development of a ragged appearance. This is often called a "soft pinch" because it may be done with the fingers. Pines can satisfactorily be pruned only in late June and early July.

Snow and ice damage. Snow and ice damage occasionally occur to multi-stem pyramidal arborvitae. When these plants are bent and misshapen, use a piece of soft string or a strip of burlap to draw the stems together. Pruning can finish repairing the damage. Be certain to keep the soft string or strip of cloth in contact with stems instead of the foliage.

Tree paints. There are asphaltic compounds especially manufactured for repairing tree wounds and painting large cuts. It is not necessary to paint any cut unless it is 1 inch in diameter or larger. When large splits occur, the split-out portion should be cleaned out and painted immediately.

Fertilization of arborvitae, yews, and junipers can be done with any lawn fertilizer (if it contains no herbicide) or a fertilizer similar to a 10-6-4 (see page 41). Applications normally are made in early April or late fall. This fertilizer should be spread on the soil beneath the spread of the branches. It is not necessary to work the fertilizer into the soil. Use the following rates:

Pyramidal evergreens: 1 tablespoon per foot of height.

Globes and spreaders: 1 tablespoon per foot of diameter.

Spruce and fir: apply one-quarter pound of fertilizer per inch of diameter of the trunk. Spread fertilizer on the soil under the branches.

Pines: generally not recommended until one year after transplanting, except for superphosphate or bone meal. When fertilizer is needed use the same amounts as for spruce and fir.

Root pruning. Root pruning slows the growth or dwarfs a plant. It should be done once every 2 to 3 years. To accomplish root pruning, tie up the branches carefully to get them out of the way. Then using a sharp spade, plunge it into the soil vertically at least 10 inches, at a distance of two-thirds of the branch spread from the main trunk. Be certain to cut the roots completely around the plant.

When transplanting is necessary, root pruning must be done in March or April of the year preceding the time of transplanting. This permits new roots to develop near the stubs, providing a compact, fibrous root system for transplanting. This is illustrated on the right side of Figure 47.

Pruning Deciduous Trees and Shrubs

Renewal Pruning

Multi-stem shrubs are renewed by removing a number of the old stems each year to promote new growth, maintain moderate size, and encourage flowering and fruiting. Each spring cut out the largest stems at the crown to stimulate new growth from the crown and remaining stems. Where a few large stems constitute the whole plant, it may be necessary to combine renewal pruning and heading back to maintain a reasonable appearance while new growth develops.

When initiating renewal pruning on large or old plants, the immediate results may be unattractive. One season's growth usually produces many new shoots to shape the future plant. Then annual renewal pruning can continue without any loss of beauty.

Before beginning to prune, examine the plant to see how much needs to be removed, how much is diseased, and what limbs are needed to maintain the natural shape of the plant.

Figure 14 illustrates cuts to make on a typical flowering shrub and shows a plant that is opened up to allow sunlight to enter, thereby increasing new growth at the base. This plant will facilitate the spraying operation for better disease and insect control.

An example of a shrub needing this kind of pruning would be the common lilac (*Syringa vulgaris*). Lilacs are very susceptible to scale, borers, and mildew. Removal of old wood to the ground takes out many of the bore- and scale-damaged limbs. This allows more air movement and sunlight, which are mildew deterrents. Plants pruned in this manner can easily be sprayed to control diseases and insects.

Following is a list of plants that can be pruned in this manner. The list is not complete, but common landscape plants are included. The plants discussed flower on one-year wood.



Shrub showing needed pruning (at left) and shrub with natural shape maintained after pruning. (Fig. 14)

Lilac (*Syringa sp.*)

Deutzia (*Deutzia Lemoinei*)

Kerria (*Kerria japonica*)

Mockorange (*Philadelphus sp.*)

Weigela (*Weigela sp.*)

Forsythia (*Forsythia sp.*)

Arrowwood viburnum (*Viburnum dentatum*)

St. Johnswort (*Hypericum sp.*)

Red twig dogwood (*Cornus alba siberica*)

Golden twig dogwood (*Cornus stolonifera flaviramea*)

See the suggestions for pruning common shrubs on page 45 to obtain information for your own shrubs.

Figure 15 illustrates what happens when hedge shears are used to prune flowering shrubs. Each cut sends out many new growing points, making the plant dense, with smaller flowers. It also causes leaf drop in the interior of the plant, which invites insects and disease trouble as well as making an unsightly plant. Avoid this type of pruning if at all possible. Such pruning at the wrong time of year also reduces or eliminates entirely the flower crop for the next year.

Heading Back

Heading back is pruning single-stem plants (miniature trees) to remove old or unwanted wood back to the main branches. The principle



Shrubs should not be pruned with hedge shears, as in the drawing on the left. The drawing on the right shows undesirable growth resulting after shearing. (Fig. 15)

is somewhat like renewal, but limbs are cut back to the base frame of a few well-placed stems instead of the ground level (Fig. 16).

Many flowering shrubs are single-stem or grafted plants. These must be pruned by heading back, which is the removal of unwanted and diseased limbs back to a main limb or basic framework limb. The same principles are followed in pruning single-stem as with multi-stem flowering shrubs. Open the plant up and reduce its size by removing damaged or unneeded older limbs.

Figure 16 indicates where and how the cuts should be made when heading back. Never stub a limb off. Cut back to the main frame limb or to a new growing point, as is illustrated in Figure 23.

Figure 17 illustrates the proper method of handling grafted plants. Pruning of the main part of the plant is the same as discussed for Figure 16. Extreme care must be taken not to damage the graft, and all growth below the graft should be removed.

Rejuvenation

Rejuvenation is the complete cutting of all stems down to 4- to 6-inch stubs. This procedure is used when multi-stem plants become too large with too many stems to justify saving any one- and two-year growth.



Shrub showing where to make cuts when heading back (at left), and shrub showing the base frame remaining after pruning (at right).
(Fig. 16)

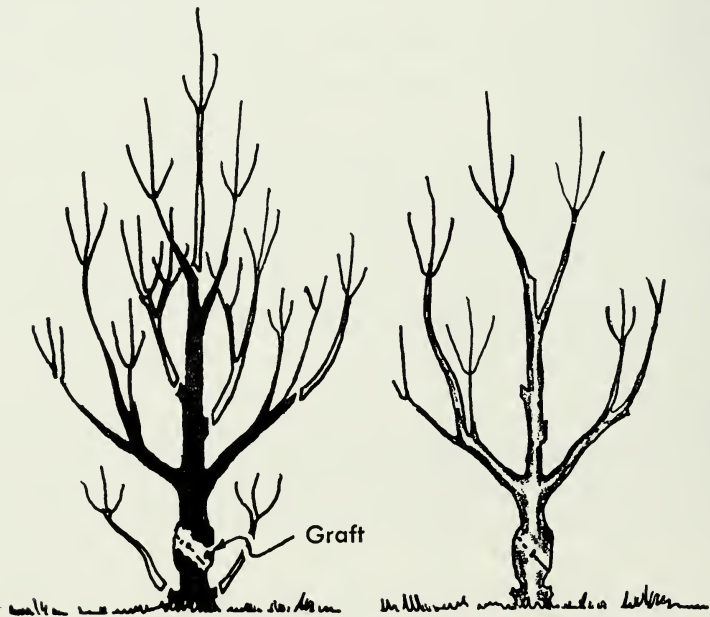

Grafted plant (at left) showing graft and needed cuts. Always protect graft and remove sprouts below the graft. The same shrub is shown at right after pruning.
(Fig. 17)

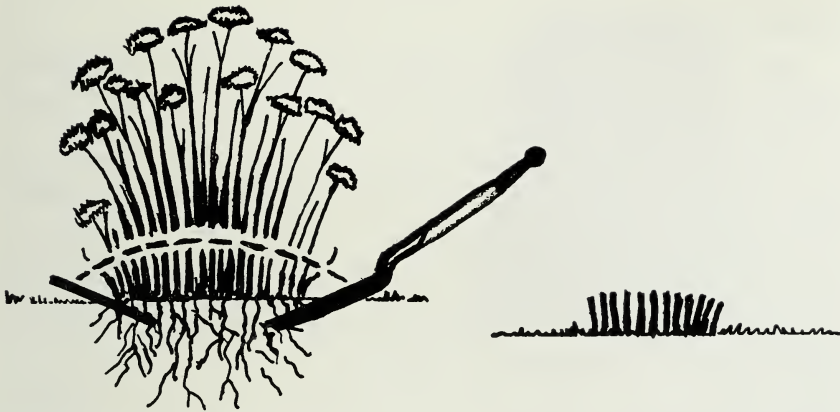

Shrub being rejuvenated.

(Fig. 18)

A plant that responds to this treatment is Anthony Waters spirea. The best time for rejuvenation is in February or March. Large old shrubs should not be rejuvenated in late spring or summer. After new growth is started, the diameter can be reduced at ground level with a sharp shovel to undercut at the base (Fig. 18).

Listed below are plants that flower on the current year's wood and that respond well to rejuvenation. They should be pruned in early spring, February, or March.

- Anthony Waters spirea (*Spirea bumaldi* 'Anthony Waterer')
- Abelia (*Abelia grandiflora*)
- Honeysuckle (*Lonicera sp.*)
- Beauty bush (*Kolkwilzia amabilis*)
- Indian currant (*Symphoricarpos orbiculatus*)
- Snowberry (*Symphoricarpos albus*)
- Slender deautzie (*Deutzia gracilis*)
- Privet (*Ligustrum amurense*)

Here are some important factors to remember when pruning flowering shrubs:

1. In most cases, prune after flowering.
2. Understand the plant's growth habits, such as mature size, flowering time, and on which year's growth the flowers form.
3. Disease and insect susceptibility of a plant will determine what type of pruning and, in some cases, when it should be done.
4. Start pruning when the plant is young and form a strong frame in single-stem plants.

Plants That Winter Kill

Plants that winter kill, such as hills-of-snow (*Hydrangea arborescens Grandiflora*), crepe myrtle (*Lagerstroemia indica*), and butterfly bush (*Vitex*), should be pruned carefully.

If the plants freeze to soil level each winter, then they should be cut off at ground level in early spring. A light mulch of straw is excellent winter protection.

In areas where some winter kill is experienced, prune in March, removing deadwood to ground level and stubbing back live wood to 6 to 12 inches. This will increase flower production and reduce falling over, as in the case of the hydrangea.

Pruning Deciduous Hedges

Hedges such as privet or honeysuckle become tall and leggy at the bottom with very little foliage at the base. This is caused by a lack of light on the lower branches. To avoid this unsightly condition, prune as shown in Figures 19 and 20 and not as in Figure 21.

Hedges pruned with perpendicular sides, or sides that angle in toward the base, will lose foliage near the base. The condition will worsen as the plant matures. If a hedge is already in this condition, it can be rejuvene-

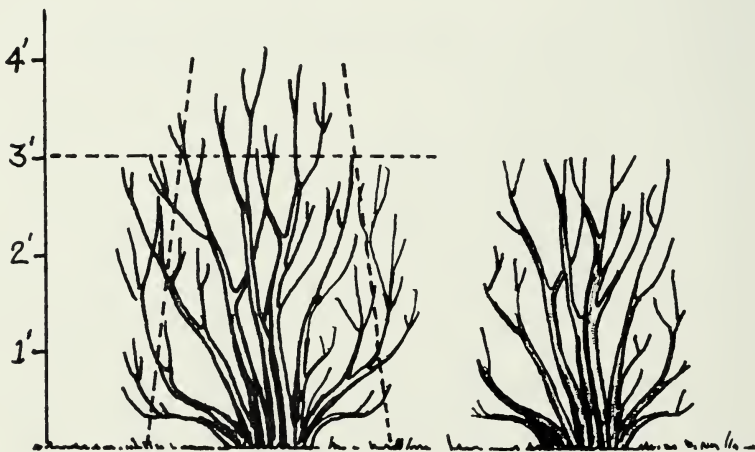

The first step in pruning a hedge is to establish lines at the proper angle for cutting (at left). The same hedge immediately after pruning is shown at right. (Fig. 19)



Spring's first growth (left) and hedge in full foliage indicating shape (right). (Fig. 20)



Hedge immediately after incorrect pruning (at left). Hedge in full foliage showing leggy, sparse condition in the lower part (at right). (Fig. 21)

nated by cutting back to a 6- to 10-inch stub and then reshaping the new growth. This should be done in early spring. At the same time, give the hedge a good application of fertilizer. This will stimulate new, vigorous growth and insure quick recovery. One caution: if the plants are weak or diseased, the condition should be corrected before rejuvenation.

Deciduous hedges should not be maintained at a permanent size, but allowed to grow an inch or so each shearing to maintain a good cover of new foliage. Such treatment gradually enlarges the hedge out of its bounds. This can be corrected by pruning back to the desired size or smaller in February or March.

Here is a list of deciduous plants you can use in a formal hedge:

- Privet (*Ligustrum sp.*)
- Bush honeysuckle (*Lonicera sp.*)
- Spirea (*Spirea sp.*)
- Pearl-bush (*Exochorda grandiflora*)
- Ninebark (*Physocarpus opulifolius*)
- Alpine currant (*Ribes alpinum*)
- Buckthorn (*Rhamnus sp.*)

Pruning Multi-Stem Trees

Multi-stem trees, the hawthorn for example, present special problems. They usually get too thick and matted in the center with dead limbs and leaves. To keep the multi-stem effect, the center must be kept open and free of trash. Trees that are pruned in this manner display their flowers, fruit, or bark much better than those left unpruned.

Remember when pruning multi-stem trees that the stems are in competition with each other. The weaker member will be crowded out if care is not taken. Try to give each limb growing room and enough open space to display itself. Figure 22 illustrates this procedure.



A multi-stem flowering tree with needed cuts indicated (at left); the same tree after thinning cuts (center); and same tree after thinning and heading back (at right). (Fig. 22)



Close-up view of procedure in heading back to a growing point (at left). After cuts (at right) the undisturbed growing points will continue to grow normally. (Fig. 23)

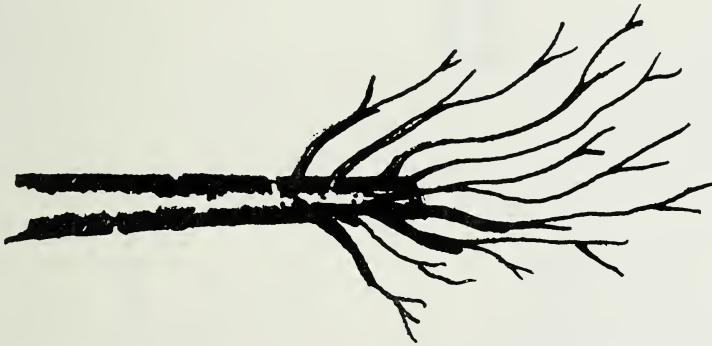

The result of a branch indiscriminately removed. The small twigs are weak, will fruit or flower very little, and will give the tree a deformed look. (Fig. 24)

The best time to prune most flowering trees is in early spring. True, this will remove some flower wood, but the remaining flowers will be improved. The height can be reduced after the tree is thinned back to the basic frame, as seen in Figure 22. Head the plant back as shown in Figure 16. A closeup of this procedure on individual limbs is shown in Figure 23.

Never stub a limb off to reduce its size. Depending on the species or age of the limb, stubbing off will have one of two results. It will either die back to the main limb or send out many small branches at the cut to form a "bird's nest." This is unattractive, and each of these small limbs is weak. This is illustrated in Figure 24.

Close-up view of water sprouts occurring on a main limb near the trunk. (Fig. 25)

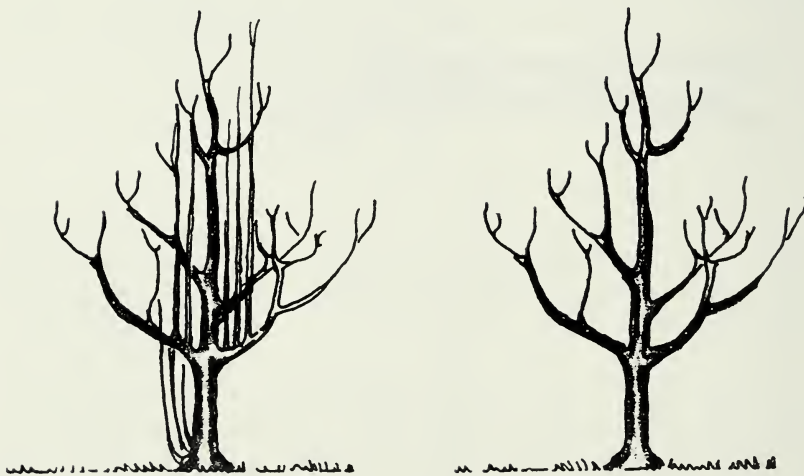

A normal tree (right). The same tree with water sprouts, which can occur on the limbs or at the base of the trunk (left). (Fig. 26)

The tree takes pruning in early spring better than at any other time of the year. The framework is bare, making easier the selection of the limbs to be removed.

Water sprouts. Many ornamental plants, such as crabapples, have a tendency to develop water sprouts (Figs. 25 and 26). These are rapid-growing, vertical shoots that need removal since they will seldom flower or fruit and will destroy the shape of the tree. These shoots also take needed nutrients from the tree that would be used for developing flowers or fruit. The shoots should be removed flush with the limb from which they arise.

Here is a list of plants that are likely to develop water sprouts:

- Crab apple (*Malus sp.*)
- Hawthorn (*Crataegus sp.*)
- Flowering cherry (*Prunus sp.*)
- Flowering peach (*Prunus sp.*)
- Blackhaw (*Viburnum prunifolium*)
- Purpleleaf plum (*Prunus*)

Pruning Vines

Vines present completely different problems from any of the other ornamental plants. The problems and pruning vary with the different uses of the vines. Vines left unpruned for many years become unattractive. They harbor wasps, collect trash, and damage structures. They should be pruned to prevent such hazards. Vines are usually used to cover an arbor.

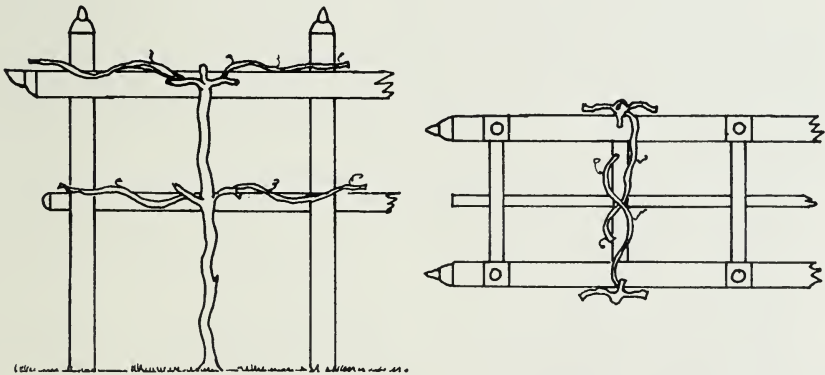

The side and top view (left and right) of a typical arbor. A cane is left on each spur for each rail on the arbor, including the top. Next year this cane should be cut back to the spur, leaving one new cane per rail. This is repeated annually. (Fig. 27)

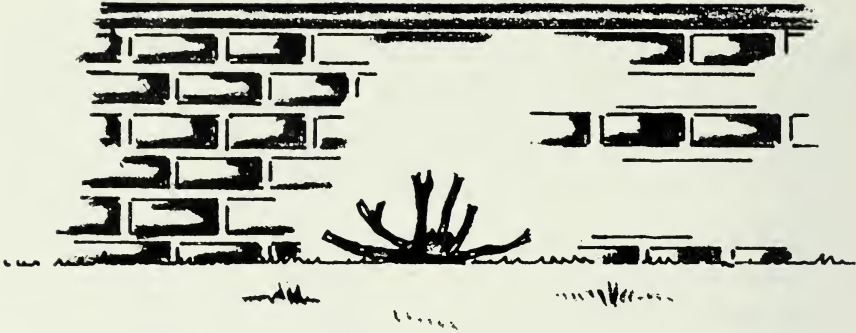

Vine pruned to a stump, leaving 5 or 6 one-year-old spurs. (Fig. 28)

or wall. Used in these ways, they can easily be pruned to give a clean, well-kept appearance that displays flowers or fruit to advantage.

The first step is to select a base cane, or trunk, for the vine used on an arbor. This is illustrated in Figure 27. These vines should be pruned annually in February or March back to the base cane. Leave five or six canes of one-year-old wood in 6- to 12-inch spurs or three- to four-foot lateral canes of this one-year-old wood. Enough of these laterals should be saved to correspond to the number of braces or wires on the trellis (Fig. 27). All other canes should be removed regardless of age.

If the vine is used on a wall, create a stump that is multi-stemmed. Then at pruning time simply cut all the vine back to 6- to 12-inch stubs. Remove all old or unwanted canes to the stump. The number removed will depend upon the area the one vine needs to cover. The tendency is to leave too many; five or six healthy 12-inch canes are satisfactory as is shown in Figure 28.

Here is a list of vines that take this type of pruning well:

- Grapes (*Vitus sp.*)
- Trumpet vine (*Campsis sp.*)
- Bittersweet (*Celastrus sp.*)
- Wintercreeper (*Euonymus sp.*)
- English ivy (*Hedera helix*)
- Honeysuckle (*Lonicera sp.*)
- Boston ivy (*Parthenocissus tricuspidata*)
- Wisteria (*Wisteria sp.*)

Pruning Clematis

Of all landscape plants, clematis is one of the most delicate and difficult vines to grow. For purposes of maintenance, there are summer-blooming and fall-blooming classes.

The summer-blooming class (*Clematis var.*) is the most difficult to prune and keep through the winter, especially north of Zone 2 (see page 44). The first step in pruning these large-flowered summer-blooming varieties is to develop a strong, vigorously-growing plant.

The most common growing error is the lowering of the soil pH with the use of peat moss. Add agriculture lime to make peat a beneficial mulch. Clematis requires a pH of 7.0 or above which can be obtained by using bone meal or agriculture lime. Use several cups of lime or two cups of bone meal in the planting soil mix, which should usually be a bushel or more.

Plant in a well-drained area or on a slight mound. Fertilize the plants with a good all-purpose fertilizer, such as 10-10-10, at a rate of one cup in early spring. Spread the fertilizer evenly over the soil in a two-foot radius and work it into the soil lightly.

Prune summer-blooming clematis in early spring (March or April) or just before new growth begins. Remove winter-killed stems at this time and remove any unwanted vines without fear of losing any more because of freezing. Such treatment makes it possible to fertilize, prune, and give the plant all the care it needs during the year at one time.

Fall-blooming clematis (*Clematis paniculata*) can be given the same care as the summer-blooming varieties, except they will have to be thinned and trimmed until mid-July. The vine grows so rapidly that it becomes overgrown and unsightly if left uncared for. The vines will grow in layers, one on top of the other, causing the lower ones to die out. Such an overgrown condition reduces the number and size of flowers and does not display the deep green foliage to best advantage. Fall-blooming clematis is one of the best trellis and arbor vines.

Pruning Young Shade Trees

Pruning and care of young shade trees are very important if trees are to be strong, attractive, and long-lasting. Newly planted trees do need to be pruned, and they must receive adequate moisture.

Newly planted trees should be pruned to a single leader, as illustrated



A young shade tree developing a double leader (at left). The space indicates the cut to make. The plant after the cut is shown at right. (Fig. 29)

in Figure 29. This may make the tree look a little one-sided, but it will quickly fill in and be much stronger.

Figure 30 illustrates some good practices to use when planting new trees. Stake the tree firmly to avoid loosening by wind. The wires around the trunk should be covered with a length of old garden hose, not tightly twisted. The wire should be made taut at the stake, not at the tree.

For the first year newly planted trees need to be kept moist the entire depth of the ball of soil in which they were planted. To insure this, a basin must be provided to hold enough water. Without a basin, most of the water runs off and does the tree little good.

Many times when the tree comes from the nursery, it should be thinned as illustrated in Figure 30. Do not remove the limbs from the bottom

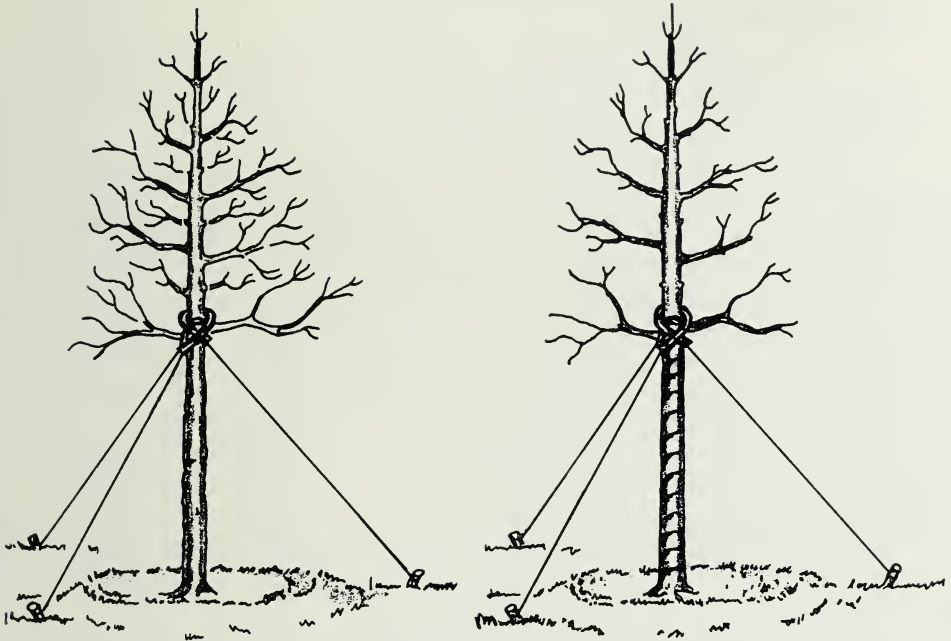

A newly planted shade tree indicating proper planting, bracing, and pruning cuts to make (at left). Same tree after pruning (at right). (Fig. 30)

upward to reduce the foliage, but thin out. When lower branches are all removed, it lengthens the time needed to produce a strong trunk that can stand alone. Never remove the leader or tip of the tree to reduce the number of branches.

This pruning can be done at the time the tree is planted. The stakes and water basin should remain for the first growing year at least. For larger trees four inches or over in trunk diameter, the stakes and water basin should remain two years.

Fertilizer is more often misused than properly used on young shade trees. If the soil is average in fertility, use little or no fertilizer at planting time. The second spring after planting is a good time to begin fertilizing. Rates and methods are given on page 36.

Wrapping the trunk of a newly planted shade tree is a very good practice to protect it from sun which scalds the bark and from winter desiccation. It also provides some protection from rodents and insects. Begin wrapping at the lower limbs and wrap downward to the base of the trunk.

Pruning Large Trees

Pruning of large trees should be kept to a minimum, since it weakens the tree. However, there are times that some corrective pruning should be done to remove diseased or otherwise damaged wood.

Contrary to popular opinion, pollarding or dehorning a tree does not make it strong nor does it help the appearance, as illustrated in Figure 31 (bottom right drawing). The stubs will die back to the next growing point or send out many switches that are weak and unattractive. The broom effect created by switches is shown in Figure 24.

Figure 31 (upper left) shows a tree before ice or storm damage and indicates typical damage. The damage shown (Fig. 31, upper right) is severe, but the tree can be saved for many more useful years. True, it will not be a pretty tree for a few years, but it will recover to a great degree.

Make the cuts flush, as shown in Figure 31 (lower left), instead of leaving stubs as shown in Figure 31 (bottom right). A close-up of the proper cut is shown in Figure 41.

Pruning a large tree is a severe shock to the tree and has a dwarfing effect on it. To counteract this, the tree should be fertilized (see page 36) and watered if it is an important landscape tree.

The year after this initial pruning is important if the tree is to return to some measure of its original beauty. The tree will produce many unbalanced branches which should be thinned by removing the weaker, undesirable limbs as they occur. This will help maintain balance and strengthen the tree.

Pruning large trees can be dangerous if the proper equipment is not used. It is best to have a qualified tree surgeon do the job with proper guidance. Cuts over two inches in diameter made in an operation should be painted with a tree wound paint to slow decay and promote quick healing.

Cross limbs and roots. Secondary limbs that cross other limbs should be removed. Both limbs involved in this condition are damaged if the offender is not removed (Figure 32).

Cross roots sometimes can be even greater problems, particularly with shade trees. When these cross roots occur near the trunk, they cause a girdling effect and seriously hinder the growth and strength of a tree (Fig. 33). Cross limbs and roots should be cut away as soon as they are noticed (Figs. 32 and 33).

Container-grown plants. Growing plant materials in containers can be one cause of crossed or circular roots. This hazard can be avoided by



Shade tree before storm damage (top left); same tree after storm damage (top right); correct pruning (bottom left); and incorrect pruning (bottom right). (Fig. 31)



Cross limbs must be removed to prevent the tree from weakening itself. (Fig. 32)



Cross roots can have a girdling effect, particularly on shade trees, and can stunt a tree's growth. (Fig. 33)

proper planting. Always remove plants from their containers before planting, even though they supposedly can be planted with containers. This will check improper root growth. If roots are crossed or growing in a circular pattern, spread them or cut away the worst roots. Removing plants from their containers will not injure them. If plants were properly grown and there is no delay before planting, they should root into the soil easier if planted without containers.

Weak crotches. This condition, particularly in shade trees, is very serious. The branches, as illustrated in Figure 34, are weakened and will



Narrow-angle, weak crotch that must be avoided if at all possible. (Fig. 34)

The wide-angle crotch to the right is strong and will bend easily before it breaks under heavy loads such as ice. (Fig. 35)



Cut at left has too sharp an angle; cut in center has too much stub left; and the correct cut is on the right. (Fig. 36)

split easily in ice or wind storms. The wide-angle crotch shown in Figure 35 is strong and will bend a long way before splitting or breaking.

Prune to a bud. When working with shrubbery and small limbs, always make the cuts cleanly at a narrow angle at a bud or growing point. This bud will develop into one good limb and the wound will heal, as illustrated in Figure 36.

The example shown in Figure 36 (left) has too much angle to the cut.

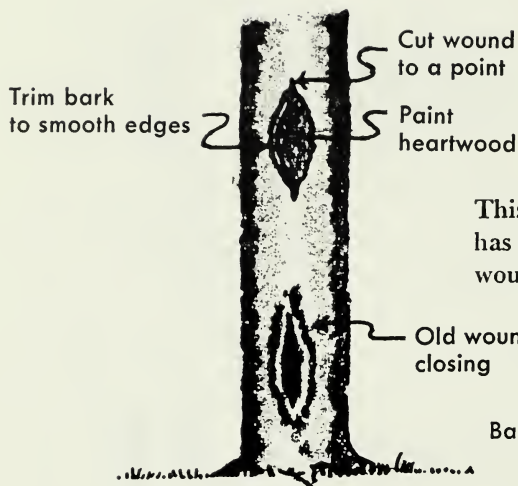

This tree has two injuries. The top wound has been prepared correctly. The lower wound is healing properly. (Fig. 37)

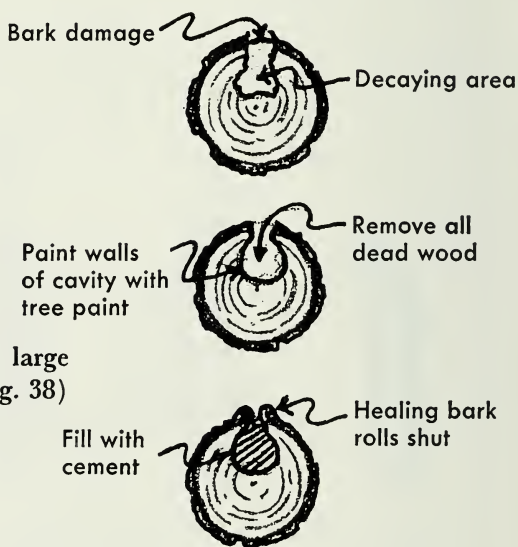

Follow these steps when correcting a large wound that has heartwood decay. (Fig. 38)

This removes live wood behind the bud. Figure 36 (center) shows a cut made too far from the bud. The result of this cut will be a dying back of the stub and failure to heal quickly. Figure 36 (right) shows a correct cut.

Correcting trunk damage. Never leave a tree injury untreated. If proper steps are taken, many large wounds can be corrected without permanent damage to the tree.

Cut the wound into an elongated shape as shown in Figure 37. This will allow the callous tissue to form and roll shut over the wound. If wounds up to 6 or 8 inches in diameter are cleaned with an antiseptic and shaped as illustrated in Figure 38 they will heal satisfactorily.

Larger wounds should be handled in much the same way, except that if the wound does not close or there is damaged wood, it should be removed and treated as shown in Figure 38. This will stop or slow decay and damage from insects such as termites.

Pruning large limbs. Pruning large limbs on shade trees can be disastrous (Fig. 39) if one simple precaution is not taken. Make an under cut away from the main trunk as shown in Figure 40, then a top cut in the same area. This will remove the weight and bulk, leaving a manageable object to handle.

Then make a smooth flush cut next to the trunk from bottom to top. Figure 40 illustrates this method. Make your cuts as shown, beginning with 40A. Figure 41 shows what happens when stubs are left. The wound cannot heal. Figure 41 illustrates what happens when a side branch is removed improperly. A dead snag is left that will increase decay down into



Incorrect removal of a large limb allows bark to be stripped down the trunk, doing severe damage. (Fig. 39)



Correct cuts in order from A to D when removing a large limb. (Fig. 40)



Leaving stubs allows decay to begin and gives the tree no chance to heal itself. (Fig. 41)

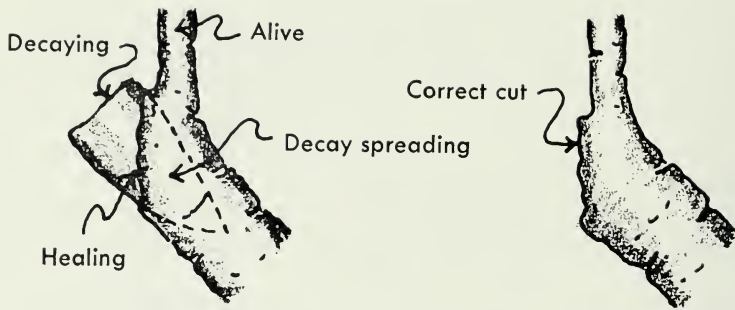

Large limb removal is bad in any circumstance, especially if done incorrectly as illustrated on the left. Correct cut of the same limb is shown on the right. (Fig. 42)

the heart of the remaining limb. If the cut was made as shown in Figure 42 the limb might heal, or at least decay would be retarded.

Where to make pruning cuts. When removing a large limb, always cut it back to the trunk or to another larger limb. Never leave a stub as illustrated in Figure 41.

Fertilization. Fertilizing large trees should be done in holes below the surface of the soil. Tree roots grow mainly in an 18- to 24-inch-deep zone. Fertilizer in amounts needed for shade trees would burn the grass if applied on the surface. Surface-applied fertilizer will not penetrate very rapidly and, as a result, most will wash away before benefiting the tree. Figure 43 illustrates proper placing of the holes. Always start at least 3 feet away from the trunk of the tree.

Small trees 6 inches or less in diameter should be fertilized at a rate of 5 pounds of 10-6-4 or similar analysis per inch in diameter. A tree 4 inches in diameter would get 20 pounds of fertilizer.

Large trees over 6 inches in diameter should receive 10 pounds per inch of diameter of the trunk. That would give a 10-inch-diameter tree 100 pounds applied as illustrated in Figure 43. For larger trees apply the fertilizer over a two- or three-year period.

Follow these steps:

1. Measure the diameter of the trunk 3 to 4 feet above ground.
2. Make holes with a punch bar or soil auger.
3. Fill holes with water after fertilizing and then seal hole with sand or garden soil.



Placement and depth of fertilization holes. (Fig. 43)

4. Make the last line of holes at the drip line of the tree.
5. Apply fertilizer only in early spring (February and March).

CAUTION: apply no more than 100 pounds of 10-6-4 during any one year, regardless of the size of tree.

Pruning Roses

Hybrid teas, floribundas, grandifloras, and polyanthas should be pruned back to 15- to 18-inch stubs in late fall. In areas where winters are severe, design the plant to fit easily into a winter cover (Fig. 44). A basket or commercially prepared cover can be used to protect the plant in winter.



Prune tea and hybrid roses back to 15- to 18-inch stubs in late fall. Mulching or some winter cover over the crown may be needed. (Fig. 44)

Do not apply this cover until the plant is dormant and remove it early enough in spring to avoid forcing (causing the plant to leaf out prematurely) the plant too soon. After the covers or mulch are removed prune canes back to 12 inches or to a strong bud and thin the plants to 4 or 5 canes.

Bush or hedge roses should be pruned after the spring flush of flowers or as needed. Old canes and diseased wood should be removed to keep the plant as open as possible. This promotes better flowers and helps with disease control.

Climbing and rambling roses should be pruned immediately after they bloom. Remove the old canes (two and three years old) to the crown or to a strong shoot. This prevents wasted energy into the old stems and reduces disease spread to the new shoots. The second best time to prune is early fall. After the old canes are removed, train and fasten the new shoots to cover the trellis.

Where winters are severe, climbing and rambling rose canes must be given winter protection. Lay the canes on a bed of straw and cover with

more straw. Be sure to include the crown. Keep the straw in place by tying it or covering it with a small amount of soil. When winter damage occurs, prune in early spring. Remove all damaged wood and put the canes or shoots back on the trellis.

Everblooming climbers should be pruned after the spring flush of flowers to remove old flower clusters and weak wood. Maintain an open vigorous plant that is the desired size.

When cutting roses for indoor use, remove all of the flower stem, except the last two leaves, to help force strong shoots from near the base of the plant and to help prevent a matted, thorny bush.

Bush or hedge roses should be pruned after the spring flush of flowers or as needed. Old canes and diseased wood should be removed to keep the plant as open as possible. This promotes better flowers and helps with disease control.

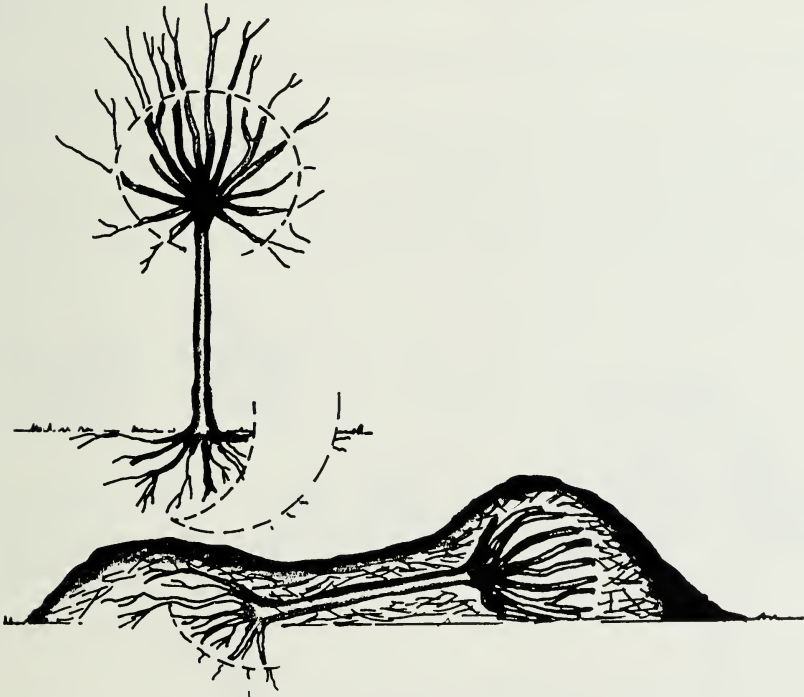

Broken lines indicate roots and soil to be removed when preparing winter protection for rose trees. Bottom drawing shows the tree after it has been pulled over and encased in straw. The straw is then covered with 3 to 4 inches of soil. (Fig. 45)

Tree roses. These are plants that have been grafted three to four feet above the ground. This complicates the whole problem of pruning and winter protection. The head of the plant should be pruned much the same as the tea rose, since many are tea roses.

In areas where the temperature drops below zero, these plants should be covered with straw and soil the same as climbing roses. To do this, one side of the plant must be undercut to lay it down on a bed of straw, as in Figure 45. Cover the plant with straw and tie securely, then cover with several inches of soil. This will tear some of the roots loose but after the rose is put upright in spring, it will recover quickly. The protection should be applied after a hard frost and removed after the danger of a hard freeze in spring.

Prune so the rose tree will fit in the winter protection in the fall after a frost. Pruning to shape the plant should be done in the spring. At that time, remove all dead wood and leave six to ten 12-inch canes evenly spaced over the head of the plant.

Pruning Rhododendrons, Including Azaleas

Rhododendrons should be pruned very lightly if at all. Removal of flower stems of specimen plants will give them a cleaner appearance and will promote quicker side branching.

Rhododendron and the evergreen azalea should be pruned after they flower. If heavy pruning must be done (Fig. 46), remove leading branches



For yearly maintenance of the plant, clip out the flower heads as shown at left. For heavy pruning, cut back one or, at most, two whorls, as shown at right. Cutting back any further risks killing part of the plant. (Fig. 46)

at a whorl. This pruning should be done over a period of two or three years. Reduce one-half or one-third of the taller branches back to desired height or below. Never cut into areas of sparse foliage, always cut back to a green growing point. Cuts that are made in the defoliated areas of the plant may never recover. This severe type of pruning should be done as soon after flowering as possible.

Deciduous azaleas should be pruned after they flower (Fig. 46). The deciduous azalea can be pruned much harder than the evergreen. These plants can be pruned like the single-stemmed flowering shrubs (see page 16), such as is described for grafted lilacs (Figs. 16, 17, and 23). The only exception is to do the pruning over a two-year period.

Root pruning of rhododendron and azaleas is never recommended. Even cultivation for weed control is harmful. Mulching will accomplish the same purpose as cultivation, and will provide winter protection and supply moisture to the shallow roots. Peat moss or rotted leaves are excellent materials and will help maintain an acid soil in which the rhododendron will thrive.

Pruning Hydrangeas

“Hills of snow” hydrangeas and florist hydrangeas can be pruned back every year to control size. Flower production will be maintained as long as the plants are adequately watered and receive proper winter care.

“Hills of snow” are white and bloom on the current season’s growth. Early spring pruning should eliminate all dead wood and cut back live wood to maintain moderate size. Thin the surviving stubs to provide adequate space for strong growth and heavy flowering.

Florist hydrangeas are blue or pink depending on acidity of soil. Acid soil promotes the blue color. Florist hydrangeas produce flowers from terminal buds on the previous season’s growth. Prune immediately after bloom (early August) to 6- to 8-inch stubs and thin the stems to permit development of new shoots. Fall pruning or winter injury destroys the flower buds and prevents flowering. Winter protection of the terminal buds in Zone 2 (see page 44) is necessary to insure annual bloom.

General Information

Fertilization. Fertilization is often either overdone or not done at all. Points to remember are the effects that different fertilizers have on plants. Nitrogen, the first number shown on an analysis label (e.g., 10-10-10), promotes fast growth, particularly of hedge and evergreen foliage. However in

some cases it will reduce beauty and winter hardiness in flowering shrubs.

A fertilizer with the analysis of 10-6-4 would contain 10 pounds of nitrogen in 100 pounds of product. It would be good for hedges, evergreens, and lawns. This analysis would be a fair blend for flowering shrubs if used in very light amounts.

A good analysis for flowering shrubs would be 5-10-10. It would contain 5 pounds of nitrogen in 100 pounds, 10 pounds of phosphate in 100 pounds, and 10 pounds of potash in 100 pounds. This would give much more phosphate and potash with the same number of pounds applied.

Normally fertilizer is sold in 50-pound bags. So in 50 pounds, analysis 5-10-10, you would be buying 2½ pounds of actual nitrogen, 5 pounds of phosphate, and 5 pounds of potash. Any fertilizer sold must have the analysis number on the bag. Know what is in the bag, and you can regulate the rate to fit any situation with almost any analysis of fertilizer.

For example, a bag of fertilizer with an analysis of 1-1-1 that cost \$2.00 per bag may not be nearly the buy it seems. Compare it with a bag with the analysis of 10-10-10 selling for \$4.00. With the analysis of 1-1-1 you pay \$2.00 for 3 pounds of actual nutrients. With the 10-10-10 analysis fertilizer you get 30 pounds of actual material for \$4.00. Do not buy a pretty bag, buy what is in it.

Shrubs vary greatly in the amount and kinds of fertilizer needed. Generally for a 4-foot-wide and 4-foot-tall shrub, a cup of 10-6-4 fertilizer would be adequate. It should be spread evenly beneath the spread of the branches, but not within a 1-foot radius of the crown. Small plants would take less, and for an 8-foot shrub two cups spread over a 4-foot to 5-foot radius would be satisfactory.

Examine the plant and make sure it needs fertilizer before you fertilize. The plant could be suffering from a lack of sun or water, too much shade, or poor drainage. All of these conditions give the plant symptoms similar to a nutrient deficiency.

Wrapping. Wrapping can be an important step in protecting a newly planted shade tree from sun, wind, insects, and rodents. Specially prepared paper wrap material should be used because it has many inherent qualities that cannot be duplicated with any substitutes. The wrap is crinkled to give it more elasticity for a tighter wrap. The wrinkled surface also provides good insulation against sun and wind. The paper is treated to withstand breakdown in rainy weather. It also gives some protection against insects and rodents. A wire mesh ring around the base of the tree is still the best rodent protection, however.

Transplanting native trees. This has always been a problem, however not an unsurmountable one. It is best to root-prune native trees at least one growing season before transplanting into a yard (Fig. 47).

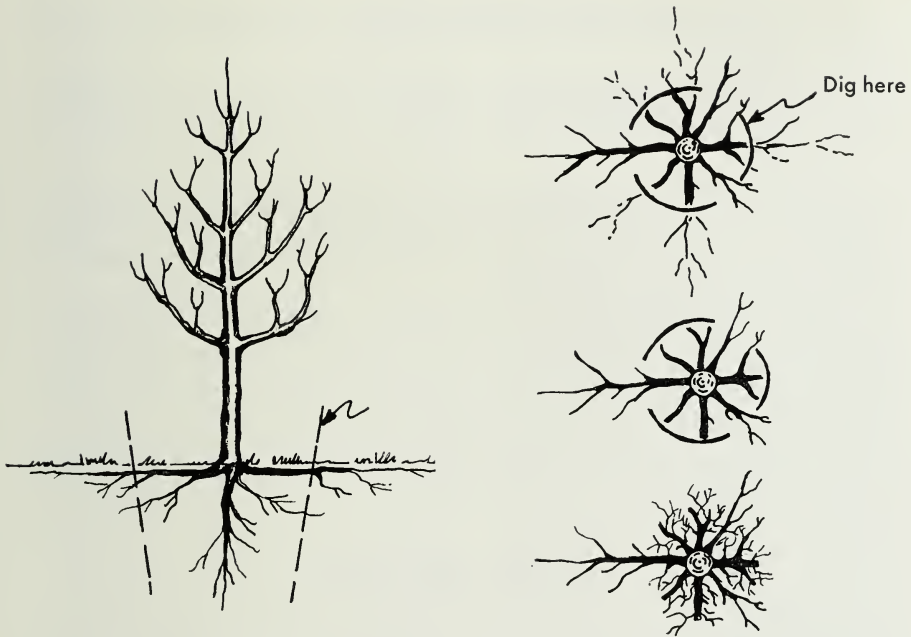

When transplanting native stock, remove one-third to one-half of the roots by plunging a sharp shovel into the soil in a ring around the tree (see broken lines). The three drawings at right are a top view of the tree and show the progression of regrowth of the roots after pruning. (Fig. 47)

Root pruning is accomplished by removing one-third to one-half of the roots by plunging a sharp shovel into the soil into the soil in a ring around the tree. Space the shovel cuts intermittently around the tree as illustrated in Figure 47. The ring should be the size of the ball of soil intended for removal at transplant time. If this procedure is followed in March and again in July, the tree should be moved satisfactorily.

A tree should be root-pruned even if it is to be moved with bare roots, because the pruning increases the number of fibrous roots near the trunk.

A tree should be moved as soon as it can be dug in early spring, preferably just as the frost leaves the soil. Settle the tree with plenty of water. Make a mud slurry in the planting hole. This will make the tree unstable for a short time, so it should be staked.

Remember that native trees will have fewer roots, so water heavily and often.

Fertilize native trees at planting time very cautiously. Frequently fertilizer is applied too heavily and burns what few roots remain. The best and safest way to insure proper growth of the tree is to fill the planting

hole with good, dark top soil, which gives more than adequate plant food for the first year.

Top thinning is important to the success of native trees that are moved. This can be done as shown in Figure 30. Do not remove central leaders for any reason.

Bare-root plants. Bare-root stock is easy to handle and, if done correctly, it is a very satisfactory way to transplant. The roots of the stock should be soaked overnight in a tub of water. If the plants are extremely dry, a 24-hour soak is even better.

When transplanting trees a hole should be dug wide enough to accommodate the roots when they are extended. Never curl or squash them into a narrow, deep hole. When the hole is properly prepared, a slurry of good top soil and water should fill it. After the slurry dries for an hour or two, more soil will be needed to finish filling the hole. Always maintain a water basin around the tree for at least a year, as illustrated in Figure 30.

INSECT CONTROL

Suggestions for controlling insects of shrubs and trees are included in Circular 900, "Insecticide Recommendations for the Homeowner." Insecticide recommendations are revised annually, so they were not included in this publication. Circular 900 may be obtained from your local Extension adviser.

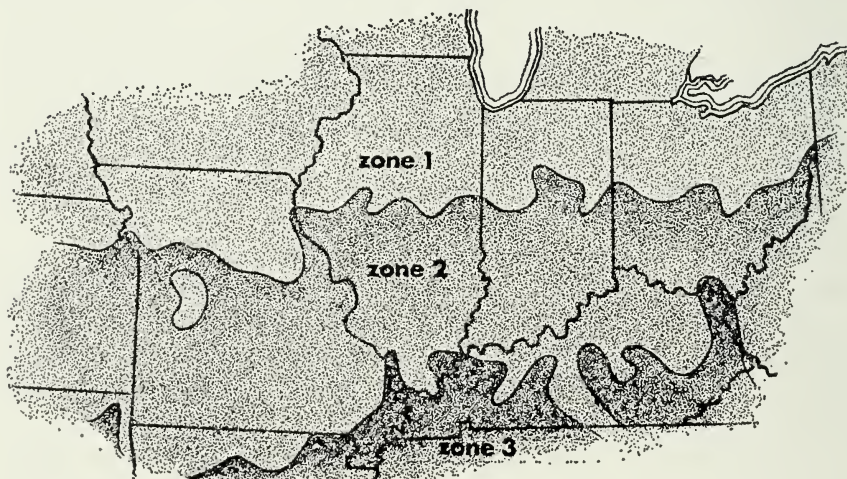

HARDINESS ZONES of the Midwest. This map is a reproduction of a portion of the United States map prepared by the U. S. Department of Agriculture and the American Horticultural Society. For convenience, the USDA zone numbers have been changed to Zones 1, 2, and 3. Zone 1 is the same as USDA Zone 5; Zone 2 is the same as USDA Zone 6; and Zone 3 is the same as USDA Zone 7.

HOW TO PRUNE COMMON SHRUBS¹

ABELIA, GLOSSY (*Abelia grandiflora*). Zones 2-3. Medium rate of growth. Dense plant, excellent foliage, and small flowers appearing during most of the summer. Responds well to rejuvenation type of pruning done every 2 or 3 years in early spring. Height: 5 feet. Spread: 4-5 feet.

ALMOND, FLOWERING (*Prunus glandulosa*). Zones 1-3. Slow to medium growth. Upright. Single- or double-flowering varieties available. Prune in early spring to remove old or diseased wood at ground level by using the renewal method. Height: 4 feet. Spread: 4 feet.

AZALEA, DECIDUOUS (*Azalea mallis* and *Exberry hybrids*). Zones 1-3. Slow-growing, low, well-shaped, symmetrical plant. Attractive foliage, showy flowers. Many varieties available in numerous flower colors. Prune as little as possible. Maintenance prune by cutting out old flower stems. Corrective cuts or severe pruning should be done early in spring. Use the heading-back method. Height: 3-6 feet. Spread: 3-5 feet.

AZALEA, EVERGREEN (*Azalea Kurume*). Zones 2-3. Slow-growing evergreen. Attractive foliage and flowers. Prune as little as possible and use the heading-back method. Remove old flower heads for better flowers the next year. Height: 4-5 feet. Spread: 4-5 feet.

BARBERRY, JAPANESE (*Berberis thunbergi*). Zones 2-3. Slow-growing, dense, round plant, good in all seasons. Red-foliage variety also available. Bar-

berry used other than in hedges should be pruned in early spring as a single-stem plant. Height: 5-7 feet. Spread: 4-7 feet.

BARBERRY, MENTOR (*Berberis mentorensis*). Zones 2-3. Slow-growing, upright, semi-evergreen plant. Withstands dry summers and low winter temperature. Good substitute for wintergreen barberry. Old plants can be pruned by the rejuvenation method in early spring. If plants are in a hedge, use the shearing method described for hedges (Figs. 19 to 21). Height: 5-6 feet. Spread: 4-5 feet.

BAYBERRY, NORTHERN (*Myrica pensylvanica*). Zones 1-3. Slow to medium growing. Compact, rounded, with excellent semi-evergreen foliage and fruit. Sexes separated. Combines well with junipers. Prune as needed in early spring to protect berry crop. Can be severely pruned because it recovers rapidly. Use the heading-back or rejuvenation method. Height: 5 feet. Spread: 3-5 feet.

BEAUTYBUSH (*Kolkwitzia amabilis*). Zones 1-3. Slow growing, broad, vase-shaped. Old large limbs should be removed to ground. Prune hard and regularly in spring. This plant becomes too large for most home grounds. Use the renewal method and the heading-back method in combination when working with old woody plants. Height: 6-10 feet. Spread: 6-9 feet.

BLUEBEARD (*Caryopteris clandestensis*.) Zones 1-3. Fast growing, round, and spreading. Valued for late flowers. In Zones 1 and 2, top of plant will die back to ground and plant will require heavy pruning in early spring. Rejuvenate in early spring. Height: 3-4 feet. Spread: 4 feet.

¹ The three basic techniques of pruning shrubs — heading-back, renewal pruning, and rejuvenation — are described on pages 15, 16, and 17.

BUCKTHORN, COMMON (*Rhamnus cathartica*). Zones 1-3. Medium rate of growth, round and dense, handsome foliage. Tolerates pruning with the heading-back method in late spring. Height: 12 feet. Spread: 10-12 feet.

BUCKTHORN, TALLHEDGE (*Rhamnus frangula* "Columnaris"). Zones 1-3. Fast-growing hedge plant that does not do well when sheared. The plant can be maintained in the narrow hedge form by selective cutting of side branches and using the heading-back method of pruning. Make as few cuts as possible. Height: 18 feet. Spread: 3-5 feet.

CHERRY, MANCHU (*Prunus tomentosa*). Zones 1-3. Fast growing, broad, spreading, rounded. Showy when in flower. Prune with the renewal method and head back slightly. Height: 8-10 feet. Spread: 10-15 feet.

CINQUEFOIL, BUSH (*Potentilla fruticosa*). Zones 1-3. Slow growing, bushy, dense. Can be pruned heavily. Chief value lies in its long period of flowering. Tolerates rejuvenation pruning. Remove only diseased or damaged wood; prune in early spring. Height: 3 feet. Spread: 3 feet.

CORALBERRY, CHENAULT (*Symphoricarpos chenaulti*). Zones 2-3. Fast growing; low, loose growth. Larger fruit than Indiancurrant Coralberry. Prune with the renewal method unless the plant is old and woody, then rejuvenate. Height: 3-4 feet. Spread: 4 feet.

CORALBERRY, INDIANCURRENT (*Symphoricarpos orbiculatus*). Zones 1-3. Fast growing, round, dense. Good in shade but tolerates sun. Clustered fruit persists. Rejuvenates well when needed; prune in early spring. Prune with the renewal method unless the plant is old and woody,

then rejuvenate. Height: 3-4 feet. Spread: 3-4 feet.

COTONEASTER, BEARBERRY (*Cotoneaster dammeri*). Zones 2-3. Slow-growing, prostrate, evergreen plant. To shape this plant, head back. Usually needs little pruning. Height: 12 inches. Spread: 6-12 inches.

COTONEASTER, PEKING (*Cotoneaster acutifolia*). Zones 1-3. Slow growing, erect, and spreading. Requires little care. Tolerates pruning. Withstands wind. Prune with the heading-back method. Height: 8-10 feet. Spread: 8-10 feet.

COTONEASTER, ROCK (*Cotoneaster horizontalis*). Zones 2-3. Slow-growing, low, dense, horizontally spreading plant, with excellent foliage and persistent fruit. Difficult to transplant. Prune with the heading-back method. Height: 2-3 feet. Spread: 4-6 feet.

COTONEASTER, SPREADING (*Cotoneaster divaricata*). Zones 2-3. Medium rate of growth. Arching and spreading. Withstands wind. Difficult to transplant. Excellent fruiting habit. Prune with the heading-back method. Height: 6 feet. Spread: 5-6 feet.

CURRENT, ALPINE (*Ribes alpinum*). Zones 1-2. Medium rate of growth. Compact and dense, attractive foliage. Does well in shade. Tolerates pruning. Usually sheared as a hedge; prune in late spring after new growth matures. If plant becomes old and woody rejuvenate in early spring. Height: 4-6 feet. Spread: 4-5 feet.

DEUTZIA, COMPACT LEMOINE (*Deutzia lemoinei compacta*). Zones 1-3. Medium growth rate, dense, compact; abundant flowers. Remove old limbs to the ground by the renewal method to avoid a woody, trashy plant. Prune after flower. Height: 4 feet. Spread: 3-4 feet. Exposure: either sun

or partial shade. Texture: medium fine. Flower effects: white in June. Fruit effects: not showy. Use: doorway, facer, group.

DEUTZIA, SLENDER (*Deutzia gracilis*). Zones 1-3. Slow growing, low, compact, abundantly flowering, reliable. Easy to transplant. Rejuvenate when needed. Head back and renew if plant is too tall or out of balance. Height: 3-4 feet. Spread: 3 feet.

DOGWOOD, GRAY (*Cornus racemosa*). Zones 1-3. Erect and spreading, medium in rate of growth. Tolerates pruning. Head back and use renewal pruning if needed. Prune in late fall or early spring. Height: 8-15 feet. Spread: 8-12 feet.

DOGWOOD, REDOSIER (*Cornus stolonifera*). Zones 1-3. Slow-growing, broad, spreading shrub valued for its winter color. Bloodtwig Dogwood (*C. sanguinea*) is similar to this variety. Remove dark stem to the ground each year to preserve the bright-colored stem for which these plants are grown. Prune in early spring. Prune with the renewal method. Some heading-back may be needed if the plant is too large. Height: 8 feet. Spread: 8-10 feet.

DOGWOOD, YELLOWTWIG REDOSIER (*Cornus stolonifera flaviramea*). Zones 1-2. Medium to slow growth rate. Spreading shrub valued for yellow twigs during winter. Remove dark stem to the ground each year to preserve the bright-colored stem for which these plants are grown. Prune in early spring with the renewal method. This plant will require some thinning of the current year's growth to avoid excess growth. Height: 8 feet. Spread: 6-8 feet.

EUONYMUS, BIGLEAF WINTER-CREEPER (*Euonymus fortunei veg-*

etus). Zones 2-3. Slow-growing evergreen shrub. Thick, leathery, glossy leaves. Grows upright with support, but otherwise forms a mounded mass. Subject to scale infestations. Rejuvenate when plant becomes old, diseased, or woody. Prune any time from February to mid-summer. Use the renewal method of pruning. When woody or scale infested, rejuvenate and treat. Height: 2-4 feet.

EUONYMUS, DWARF WINGED (*Euonymus alatus compactus*). Zones 1-3. Slow growing, dense, compact, outstanding fall color. Transplants easily. In early spring, prune with the heading-back method. Height: 6 feet. Spread: 4 feet.

EUONYMUS, EASTERN WAHOO (*Euonymus atropurpureus*). Zones 1-3. Slow growing, treelike, spreading, with outstanding foliage and fruit color. Prune in early spring the same as flowering dogwood, unless a multi-stem plant is desired; use a combination of renewal pruning and heading back. Height: 15-20 feet. Spread: 8-15 feet.

EUONYMUS, LONGWOOD (*Euonymus fortunei radicans*). Zones 1-3. Excellent, fast-growing ground cover. Can be sheared close to ground level or rejuvenated if infested with scale.

EUONYMUS, SARACOXIE (*Euonymus fortunei Saracoxie*). Zones 1-3. Slow-growing, handsome, upright broadleaved evergreen. Tolerates pruning. Rejuvenate when plant becomes old, diseased, or woody. Prune anytime from February to mid-summer. Height: 6 feet. Spread: 3-4 feet.

EUONYMUS, SPREADING (*Euonymus kiautschovicus*). Zones 2(?), 3. Slow-growing, bushy, round semi-evergreen. Flowers attract flies. Head back and rejuvenate when plant be-

comes old, diseased, or woody. Prune anytime from February to mid-summer. Height: 5-6 feet. Spread: 6 feet.

EUONYMUS, WINGED (*Euonymus alatus*). Zones 1-3. Slow-growing, dense, broad, horizontally branched; outstanding fall color. Reliable and transplants easily. In early spring, prune with the heading-back method. Height: 8-10 feet. Spread: 6-8 feet.

FIRETHORN, SCARLET (*Pyracantha coccinea*). Zones 2(?),3. Medium rate of growth. Broad, spreading, deciduous in north, evergreen in south. Fruit adds vivid color to winter scene. Prominent thorns. Tolerates pruning. Subject to fireblight. This plant is grown for its fruit, which is borne on two-year wood. To further complicate pruning, the plant is a rampant grower and new growth covers the fruit. Remove approximately $\frac{1}{3}$ of the new growth back to the main frame or ground level if the plant is multi-stemmed by using the renewal method. To make the plant more attractive, head back lightly. Prune in early spring. Height: 6 feet. Spread: 6-10 feet.

FORSYTHIA (*Forsythia* varieties). Zones 1-3. Fast growing; erect, arching, and trailing varieties available. Reliable shrub, easily transplanted. Showy flowers and good foliage. Prune in late spring after flower. Use the renewal method. Head back if the remaining plant is too stringy. Height: 8-10 feet. Spread: 10-15 feet.

FOTHERGILLA (*Fothergilla gardenii*) (*Fothergilla major*). Zones 1-3. Fast-growing shrub, flowers in spring. Both dwarf and standard forms can be pruned the same way. Use the heading-back method after flower. The standard form, *major*, has a height of 8 to 10 feet and a spread of 10 feet. The dwarf form, *gardenii*, has a height of 5 feet and a spread of 4 to 5 feet.

FRINGETREE, WHITE (*Chionanthus virginicus*). Zones 1-3. Slow growing, round, spreading, treelike. Particularly tolerant to city conditions. Leaves appear late in spring. Subject to scale insects. Sexes usually separate. When used as a multi-stemmed shrub, thin by removing old or unwanted stems to the ground. When used as a tree, prune in early spring as illustrated for dogwood. Height: 10-20 feet. Spread: 8-20 feet.

HOLLY, AMERICAN (*Ilex Opaca*). Zones 1-3. Slow-growing, tree-type holly with red fruit. Prune by lightly heading back. The plant grows with one to four upright stems with lateral branches. Some plants will grow to one side or the other, so head back to regain the conical shape. Prune in late spring after flowering. Height: 35 feet. Spread: 15 feet.

HOLLY, CONVEXLEAF JAPANESE (*Ilex crenata convexa*). Zones 1(?),2,3. Slow-growing, broader than it is high; good substitute for boxwood. Broadleafed evergreen. Tolerates pruning—can be held to any size preferred. Prune with the heading-back method. When used as a hedge, shear as described for evergreen hedges on page 13. Height: 4-20 feet. Spread 4-15 feet.

HOLLY, ENGLISH (*Ilex aquifolium Fosterii*). Zones 2-3. Slow-growing, tree-type holly with red fruit. Prune by lightly heading back. The plant grows with one to four upright stems with lateral branches. Some plants will grow to one side or the other, so head back to regain the conical shape. Prune in late spring after flowering. Height: 15 feet. Spread: 8 feet.

HOLLY, WINTERBERRY (*Ilex verticillata*). Zones 1-3. Slow growing, spreading; excellent foliage; fruit persists to midwinter. Interesting the year around. Easily transplanted.

Prune by heading back in late spring. Height: 6-8 feet. Spread: 3-5 feet.

HOLLYGRAPE, ORFGON (*Mahoeala aquifolium*). Zones 2-3. Medium rate of growth. Round, upright evergreen. Interesting holly-shaped, lustrous foliage and grapelike clusters of fruit. This plant gets tall and woody. To keep new bright green foliage abundant, prune old wood out to the ground with the renewal method to force new, lush foliage from the ground up. Prune in early spring before new growth starts. Height: 3-5 feet. Spread: 2-3 feet.

HONEYSUCKLE, BUSH (*Lonicera tatarica*). Zones 1-3. Medium-fast growing. Varieties broad, spreading, rounded. Vigorous shrubs with an abundance of small flowers and small bright-colored fruit. All honeysuckle responds well to all types of pruning in early spring or after flower. Height: 5-12 feet. Spread: 5-12 feet.

HONEYSUCKLE, HALLS (*Lonicera japonica Halliana*). Zones 1-3. Fast-growing vine with yellow flowers. Prune with the rejuvenation method. Height: 3 feet. Spread: 20 feet.

HONEYSUCKLE, WINTER (*Lonicera fragrantissima*). Zones 2-3. Medium rate of growth. Round spreading, with handsome foliage. Flowers are fragrant and appear in very early spring. Tolerates pruning. All honeysuckle responds well to all types of pruning in early spring. Height: 6 feet. Spread: 6 feet.

HYDRANGES, FLORIST'S HYDRANGEA (*Hydranges Macrophylla*). Zone 3 and southern half of Zone 2. Florist's hydranges produces flower buds on terminals of previous year's growth. Severe weather or fall pruning removes flower buds and prevents flowering. Prune after bloom

(early August) to 6- to 8-inch stubs. Space stems to prevent crowding. Mulch entire plant with leaves for consistent flowering. Height: 3 feet. Spread: 3-4 feet.

HYDRANGEA, HILLS-OF-SNOW (*Hydrangea arborescens grandiflora*). Zones 1-3. Fast-growing, broad, upright plant that gives a good texture accent. Showy flowers. Requires severe pruning in spring. Cut all dead stems in spring just after growth begins. Stub back live twigs to shape a low, more compact plant that will flower more heavily. Height: 4-8 feet. Spread: 5-8 feet.

HYDRANGEA, OAKLEAF (*Hydrangea quercifolia*). Zones 1-3. Fast-growing, upright plant with large flower heads. Prune by heading back in early spring.

JETBEAD, BLACK (*Rhodotypos scandens*). Zones 2-3. Medium rate of growth. Spreading and open growth. Excellent flower and foliage. Prune hard after flowering by the renewal method. Height: 5-6 feet. Spread: 4-5 feet.

JUNIPER, ANDORRA (*Juniperus horizontalis plumosa*). Zones 1-3. Fast-growing, low, spreading, somewhat mounding evergreen. Feathery foliage turns from silver green to lavender during winter. Very difficult to prune because of creeping growth habit. Start pruning early and prune as described for Pfitzer junipers. Prune in June or July. Height: 1½ feet. Spread: 4-5 feet.

JUNIPER, COMPACT PFITZER (*Juniperus chinensis Pfitzer Compact*). Zones 1-3. Fast to medium growing, dwarf, spreading evergreen with plumelike foliage. Very difficult to prune because of creeping growth habit. Start pruning early and prune

as described for Pfitzer junipers. Prune in June or July. Height: 5 feet. Spread: 5 feet.

JUNIPER, PFITZER (*Juniperus chinensis Pfitzer*). Zones 1-3. Fast-growing, large, spreading evergreen with plumelike blue-green foliage. In June or July prune hard as described and prune often. Height: 8-10 feet. Spread: 8-10 feet.

JUNIPER, SARGENTS OR WAU-KEGAN (*Juniperus horizontalis* varieties). Zones 1-3. Medium rate of growth. Flat, spreading, somewhat trailing evergreens. Blue-green foliage. Very difficult to prune because of creeping growth habit. Start pruning early and prune as described for Pfitzer junipers. Prune in June or July. Height: ½-1 foot. Spread: 5 feet.

JUNIPER, SHORE (*Juniperus conferta*). Zones 2 and 3. Medium rate of growth. Flat, spreading evergreen with a very soft texture. Difficult to prune because of its creeping growth habit. Prune in June or July as described for Pfitzer junipers on page 5.

KERRIA, JAPANESE (*Kerria japonica*). Zones 1-3. Medium growing, broad, loose habit with year-round interest in flowers, foliage, and twigs. Requires annual pruning. Prune two-year-old wood to the ground each year. Some new wood should also be removed to improve flower show. Prune after flowering by using the renewal method. Height: 4-6 feet. Spread: 6-8 feet.

LILAC (*Syringa* varieties). Zones 1-3. Medium rate of growth. Reliable upright round shrub. Handsome, showy flowers in both single and double varieties. This is the classic plant for renewal pruning as is described in this circular. Prune after flowering. Height: 6-15 feet. Spread: 6-12 feet.

LILAC, PERSIAN (*Syringa persica*). Zones 2-3. Medium rate of growth. Dense and shapely, valued for flowers. This is the classic plant for renewal pruning as is described in this circular. Prune after flowering. Height: 4-8 feet. Spread: 5-10 feet.

MAGNOLIA, SAUCER (*Magnolia soulangeana*). Zones 2-3. Medium rate of growth. Shrubby tree with showy flowers effective in front of evergreens. Because of fleshy roots, plants should always be moved with a ball of earth. Numerous varieties and flower colors available. The type of plant you desire determines how to prune. If you want a tree, then prune to a main frame. If a large multi-stemmed shrub is desired, then promote and protect new shoots that occur at the base. As older trunks get too large or too tall, remove them at their base. Prune in early spring before buds begin to swell. Height: 25 feet. Spread: 30 feet.

MAGNOLIA, STAR (*Magnolia stellata*). Zones 2-3. Slow growing; dense, broad, round, treelike. Showy flowers effective in front of evergreens. Will not tolerate competition with other tree roots. Because of fleshy roots, plants should always be moved with a ball of earth. The type of plant you desire determines how to prune. If you want a tree, then prune to a main frame. If a large multi-stemmed shrub is desired, then promote and protect new shoots that occur at the base. As older trunks get too large or too tall, remove them at their base. Prune in early spring before buds begin to swell. Height: 8-10 feet. Spread: 10-15 feet.

MOCKORANGE (*Philadelphus* varieties). Zones 1-3. Slow growing; varieties compact, rounded, or erect. Valued for flowers, which are usually fragrant. Prune two-year-old wood to the ground each year. Some new wood

should also be removed to improve flower show. Prune after flowering by the renewal method in early spring. Height: 4-12 feet. Spread: 4-12 feet.

NINEBARK, COMMON (*Physocarpus opulifolius*). Zones 1-3. Fast-growing, loose, spreading shrub, resembling spirea. Because of coarseness not recommended in refined small gardens. This plant can be pruned into a formal hedge. To do this, prune in late spring after new growth matures. Height: 10 feet. Spread: 10 feet.

PEARL BUSH (*Exochorda* var.). Zones 1-3. Fast-growing shrub, flowers in spring. Works well in mass plantings. Prune with renewal method and some heading back. Height: 8-10 feet. Spread: 8-10 feet.

PEASHRUB, SIBERIAN (*Caragana arborescens*). Zones 1-3. Fast growing, oval, erect and thin with age. Useful in sandy areas; good foliage mass. Prune old wood by the renewal method in early spring. Height: 15-18 feet. Spread: 12 feet.

PINE, DWARF MUGHO (*Pinus mugho mughus Dwarf*). Zones 1-3. Slow-growing, round evergreen. Easily confined to small size by pruning. Prune as described for pine, every other year in late June. On intermittent years remove all buds but two or three that formed at last year's cut. This will help keep the plant foliage from getting too dense. Height: 4-8 feet. Spread: 12-20 feet.

PLUM, FLOWERING (*Prunus triloba*). Zones 2-3. Fast growing, rounded, spreading. Prune in early spring the same as illustrated for flowering trees. Cuts larger than one-inch should be treated with a prepared wound paint. Height: 8-10 feet. Spread: 8 feet.

PLUM, PURPLELEAF (*Prunus* var. *Thundercloud*). Zones 1-3. Fast

growing, round. Prune in early spring the same as illustrated for flowering trees. Cuts larger than one-inch should be treated with a prepared wound paint. Height: 15-20 feet. Spread: 10 feet.

PRIET, AMUR (*Ligustrum amurense*). Zones 1-3. Fast growing; dense upright branches with round top. Tolerates pruning. Prune in early spring the same as illustrated for flowering trees. Cuts larger than one-inch should be treated with a prepared wound paint. If this plant is used as a hedge, shear it as described for deciduous hedges on page 20. If used as a single plant, head back in early spring or after flower. Height: 10-15 feet. Spread: 6-10 feet.

PRIVET, GOLD LEAF (*Ligustrum amurense*). Zones 1-3. Fast growing; dense upright branches with round top. Can be used as a specimen plant or an unclipped hedge. Prune by the renewal method. Height: 10-15 feet. Spread: 6-10 feet.

PRIVET, REGELS BORDER (*Ligustrum obtusifolium regelianum*). Zones 1-3. Medium rate of growth. Horizontally branching, dense foliage. Reliable, excellent form. Do not shear; prune by the renewal method to maintain good leaf and fruit color. Prune after fruit is gone or in early spring. Height: 6 feet. Spread: 6 feet.

PURPLE-FLOWERED LOCUST (*Robinia Idaho*). Zones 1-3. A fast-growing shrub that becomes erect and thin with age. Useful in sandy areas. Prune old wood with the renewal method if the plant is multi-stemmed. Head back if it is single-stemmed. Height: 15-20 feet. Spread: 10 feet.

QUINCE, FLOWERING (*Chaenomeles lagenaria*). Zones 1-3. Fast-growing, spreading plant. Good foliage, showy flowers, winter color. Prune the same as common lilac after flower-

ing or in early spring. It is important to keep the plant thinned to avoid trashy centers that are very unattractive in winter. Height: 6-8 feet. Spread: 6 feet.

REDCEDAR, CANAERT EASTERN (*Juniperus virginiana Canaert*). Zones 1-3. Medium rate of growth. Loose and open yet slender pyramidal form of evergreen. Prune as little as possible. If absolutely necessary, use the procedure described for the upright junipers. These plants are trees and should be grown as such. Sheared plants cannot be reduced in size because of the very thin shell of green foliage left to work with. If you prune back past this green material, there will be a permanent dead hole in the plant. Height: 20 feet. Spread: 8-10 feet.

ROSA (CLIMBERS AND RAMBLERS). Zones 1-3. Bloom in early summer on old canes. Prune immediately after blooming. Remove the old canes (two and three years old) to the crown or to a strong shoot. Spread: 6-15 inches as arching and vining shoots.

ROSA (EVERBLOOMING CLIMBERS). Zone 1-3. Bloom heavily in early summer and light to moderate rebloom throughout the summer and fall season. Lightly prune throughout the season to remove old flower clusters and weak wood on old stems. Remove 2- to 4-year-old canes in the fall when new canes occur for replacements.

ROSE (FLORIBUNDA TYPE) (*Rosa* varieties). Zones 1-3. Medium rate of growth. Rounded, upright, small-growing rose that flowers all season. Many varieties and flower colors from which to select. Prune out old, diseased, or unwanted canes in fall. In spring, before growth starts, reduce in size as illustrated in the section

on roses. Height: 3-5 feet. Spread: 3-4 feet.

ROSE, FATHER HUGO (*Rosa hugonis*). Zones 2-3. Fast growing, dense, rounded. Excellent, showy flowers. Prune out old, diseased, or unwanted canes in fall. In spring, before growth starts, reduce in size as illustrated in the section on roses. Height: 6-10 feet. Spread: 10 feet.

ROSE OF SHARON (SHRUB-ALTHEA) (*Hibiscus syriacus* varieties). Zones 2-3. Slow to medium growing; upright, somewhat vase-shaped; tolerates city conditions. Showy flowers in late summer. Young plants are less winter-hardy than older plants. This plant has the most unsightly base of all the ornamentals. Keep the old diseased wood cut to ground level with the renewal method to reduce the amount of shade on the base and stimulate new growth. Height: 10-15 feet. Spread: 6-10 feet.

ST. JOHNSWORT, SUNGOLD (*Hypericum* var. *Sungold*). Zones 2-3. Medium growth rate, dense, rounded. Showy flowers in summer. Prune by using the rejuvenation method only when needed, not more often than every 2 years after flowering. Height: 3-4 feet. Spread: 3 feet.

SERVICEBERRY, SHADBLOW (*Amelanchier canadensis*). Zones 1-3. Fast growing, loosely round to oval, tree-like. Good combined with broad-leaved evergreens. Prune in early spring by thinning out and heading back. Height: 25 feet. Spread: 12 feet.

SPIREA, ANTHONY WATERER (*Spiraea bumalda Anthony Waterer*). Zones 2-3. Fast growing, low, broad, flat on top. Attractive foliage, tinged pink when it first appears. Prune once every 2 to 3 years by the rejuvenation method after flowering, and this plant will bloom twice. Height: 2-3 feet. Spread: 3 feet.

SPIREA, BRIDALWREATH (*Spiraea prunifolia*). Zones 1-3. Fast growing, graceful, upright. Reliable, showy flowers, excellent fall color. Double variety available. Prune by the renewal method. Some heading back may be needed to shape the plant. Never shear off tops. That makes a very unattractive plant with a green tuft on top and a stemmy, dead base. This plant can be sheared into a formal hedge, but will have no flowers and a shortened useful life. Prune in early spring; if the plant is in a hedge, shear in late spring and mid-summer. Height: 6 feet. Spread: 6 feet.

SPIREA, VAN HOUTTE (*Spiraea vanhouttei*). Zones 1-3. Fast growing, vase-shaped, round top. Showy when in bloom. Prune two-year and older stems to the ground by the renewal method. Never shear off tops. That makes a very unattractive plant with a green tuft on top and a stemmy, dead base. This plant can be sheared into a formal hedge, but will have no flowers and a shortened useful life. Prune in early spring; if the plant is in a hedge, shear in late spring and mid-summer. Height: 8-10 feet. Spread: 8 feet.

SUMAC, STAGHORN (*Rhus typhina*). Zones 1-3. Fast growing, irregular, picturesque. Cutleaf variety available. Interesting fuzzy twigs which hold dust so avoid use in dusty areas. This is grown for its stems, so be very careful only to remove limbs that may make the plant unbalanced or weak. Prune in early spring by lightly heading back. Height: 20-25 feet. Spread: 20 feet.

VIBURNUM, AMERICAN CRANBERRYBUSH (*Viburnum trilobum*). Zones 1-3. Fast growing, dense, broad, round. Fruit showy in color and mass. This plant must be pruned differently from any of the other flowering shrubs. Usually it is a shrub with one to four main stems so it must be pruned by

the renewal method, but thinned to keep good foliage to the base of the plant. It is often pruned into a small tree shape with a single stem. That is easily done, as described for flowering trees, but to do it, the plant must be pruned to a single stem when it is planted. If all stems but one are removed on older plants, the remaining stem will be badly misshapen. Prune after flower or in early spring. Height: 6-12 feet. Spread: 8-12 feet.

VIBURNUM, ARROWWOOD (*Viburnum dentatum*). Zones 1-3. Fast growing, upright, dense, with handsome foliage. Prune by the renewal method and head back to shorten the plant. Prune after flower or in early spring. Height: 15 feet. Spread: 6-12 feet.

VIBURNUM, BURKWOOD (*Viburnum burkwoodi*). Zones 2-3. Medium rate of growth, upright, with fragrant flowers and attractive foliage. This shrub is much like a tree and for best results should be handled as such. Even if the plant is multi-stemmed, prune as illustrated for multi-stem flowering trees. Prune in early spring or after flowering by thinning and heading back. Height: 4-8 feet. Spread: 6-8 feet.

VIBURNUM, DOUBLEFILE (*Viburnum tomentosum*). Zones 1-3. Medium rate of growth. Broad spreading, interesting horizontal branching. Outstanding in flowers. This plant must be pruned differently from any of the other flowering shrubs. Usually it is a shrub with one to four main stems so it must be pruned by heading back, but thinned to keep good foliage to the base of the plant. It is often pruned into a small tree shape with a single stem. That is easily done, as described for flowering trees, but to do it, the plant must be pruned to a single stem when it is planted. If all stems but one are removed on older plants, the remaining stem will be badly misshapen. Prune after flower

or in early spring. Height: 8-10 feet. Spread: 8-10 feet.

VIBURNUM, DWARF EUROPEAN CRANBERRYBUSH (*Viburnum opulus nanum*). Zones 1-3. Medium rate of growth. Dense, dwarf irregular, picturesque. Tolerates pruning. If it is a multi-stemmed plant, use renewal pruning. If it is single-stemmed, prune by heading back.

VIBURNUM, KOREANSPICE (*Viburnum carlesii*). Zones 1-3. Medium rate of growth. Upright, with fragrant flowers and attractive foliage. This plant must be pruned differently from any of the other flowering shrubs. Usually it is a shrub with one to four main stems so it must be pruned by the renewal method, but thinned to keep good foliage to the base of the plant. Prune after flower or in early spring. Height: 4-8 feet. Spread: 6-8 feet.

VIBURNUM, LEATHERLEAF (*Viburnum rhytidophyllum*). Zones 2-3. Medium rate of growth. Upright evergreen, with lustrous, dark-green, puckered foliage. This is an evergreen in zones 2 and 3 and a semi-evergreen in zone 1. Prune with the renewal method. If the plant is old, some heading back will also be needed. This plant must be pruned in late spring after the new growth matures in June. Height: 9 feet. Spread: 8-9 feet.

WEIGELA (*Weigela* varieties). Zones 2-3. Fast growing, round, spreading, with showy flowers. Requires annual pruning because of general die-back of branches. Often suffers winter injury in north. Many varieties available. This is one of the most rapidly growing plants used in the home landscape. It can be rejuvenated. Older plants that require a great deal of pruning should be pruned after flowering or in February. Renewal prune and then do some light heading back to keep the plant in balance. Height: 4-6 feet. Spread: 5-6 feet.

WITCHHAZEL, CHINESE (*Hamamelis vernalis*). Zones 2-3. Slow-growing, upright to spreading plant, valued for early flowering and dense foliage. Root-prune before transplanting. Prune in early spring the same as flowering trees by heading back. Height: 6 feet, Spread: 6-8 feet.

WITCHHAZEL, COMMON (*Hamamelis virginiana*). Zones 1-3. Slow growing; loose irregular habit of growth; tolerates city conditions. Root-prune before transplanting. Attractive flower appearing after foliage drops in fall. Prune in early spring the same as flowering trees by heading back. Height: 12-20 feet. Spread: 12-20 feet.

YEW, DWARF SPREADING JAPANESE (*Taxus cuspidata nana*). Zones 1-3. Slow-growing, compact, spreading evergreen. Deep color. Sexes separate. This plant is easy to prune because new growth will form anywhere up and down the stem. Follow instructions given in this circular, and if a mistake is made the plant will recover in time. Height: 3-4 feet. Spread: 4-5 feet.

YEW, HATFIELD OR HICKS (*Taxus media* varieties). Zones 1-3. Slow-growing, dense, slender, conical evergreen. Tolerates pruning. Deep color. Sexes separate. This plant is most commonly used in hedges because of its columnar form of growth. Prune as illustrated for hedges. Hicks yew is sometimes used singly. In these cases, prune as described for dense yew. Height: 8 feet. Spread: 4-5 feet.

YEW, SPREADING (*Taxus media* var.). Zones 1-3. Varieties in this category are *T. densiformis*, *T. Wardi*, *T. Nigra*, and *T. Tauntoni*. Slow-growing, dense, upright evergreen. Deep color. Sexes separate. This plant is easy to prune because new growth will form anywhere up and down the stem. Follow instructions given in this circular, and if a mistake is made the

plant will recover in time. Height: 4–5 feet. Spread: 4 feet.

YEW, SPREADING JAPANESE (*Taxus cuspidata*). Zones 1–3. Slow-growing, spreading evergreen. Deep color. Sexes are separate. This plant is easy to prune because new growth will form anywhere up and down the stem. Follow instructions given in this circular, and if a mistake is made the plant will recover in time. Height: 8–10 feet. Spread: 8–12 feet.

YEW, UPRIGHT JAPANESE (*Taxus cuspidata capitata*). Zones 1–3. Slow-growing, erect, broad, pyramidal evergreen. Deep color. Sexes separate. This is the tree form of the

yew and should be planted and used as such. It can be sheared or pruned as illustrated for upright junipers, but this will only work for a short period of time. The plant will soon outgrow your efforts to keep it in bounds. Height: 10–40 feet. Spread: 15–20 feet.

YUCCA (ADAMSNEEDLE) (*Yucca filamentosa*). Zones 1–3. Fast-growing, stiff, upright, dramatic evergreen. This plant dies after flowering. Remove the stock that produces the flower. Encourage the growth of the side suckers to produce a new plant. Remove some of the suckers to prevent the plant from becoming too bushy. Height: 3 feet. Spread: 3–4 feet.

Trees Grouped According to Use

SMALL LAWN TREES (35 feet or under)

Crabapple, Flowering
Dogwood, Corneliancherry
Dogwood, Flowering
Fringetree, White
Goldraintree, Panicked
Hawthorn, Washington
Hornbeam, American
Magnolia, Saucer
Magnolia, Star
Maple, Amur
Mountainash, European
Mulberry, White
Redbud
Sassafras, Common*
Serviceberry
Silverbell, Carolina
Smoketree

MEDIUM LAWN TREES (60 feet or under)

Ash, Green
Birch, Canoe
Birch, White
Corktree, Amur
Crabapple, Flowering
Horsechestnut, Common

Horsechestnut, Ruby*
Linden, Crimean
Linden, Littleleaf
Maple, Norway
Maple, Red
Maple, Schwedler
Oak, Pin*
Pagodatree, Japanese*
Sweetgum
Yellow-wood, American
Zelkova, Japanese*

LARGE LAWN TREES (over 60 feet)

Beech, American
Beech, European
Coffeetree, Kentucky
Ginkgo
Hackberry, Common
Honeylocust, Thornless
Linden, American
Maple, Sugar
Oak, English
Oak, Northern Red
Oak, White
Planetree, London
Tuliptree
Tupelo (Black Gum)

STREET TREES

Ash, Green
Corktree, Amur
Dogwood, Flowering
Ginkgo
Goldraintree, Panicked
Hackberry, Common
Hawthorn, Washington
Honeylocust, Thornless
Hornbeam, American
Linden, Crimean
Linden, Littleleaf
Maple, Amur
Maple, Norway
Maple, Red
Maple, Schwedler
Maple, Sugar
Mountainash, European
Oak, Northern Red
Oak, Pin
Pagodatree, Japanese
Planetree, London
Redbud
Silverbell, Carolina
Sweetgum
Zelkova, Japanese

* Height varies through a range exceeding the maximum height of the group in which it is listed.



Arborvitae
(*Thuja occidentalis* 'Nigra')
Color — dark green fan-shaped foliage
(at left)



Spreading Juniper
(*Juniperus chinensis* 'Pfitzeriana')
Color — blue or green



Mugho Pine
(*Pinus mugo mughus*)

Upright Yew
(Taxus cuspidata capitata)
Color — dark green



Spreading Yew
(Taxus media 'Browni')
Color — dark green

Creeping Juniper
(*Juniperus horizontalis plumosa*)
Color — summer, blue green
winter, purple
(at right)



Upright Juniper, Cedar
(*Juniperus virginiana 'Canaerti'*)
Color — yellow green
(above)

Keteleer Juniper
(*Juniperus chinensis 'Keteleeri'*)
Color — blue green
(below)



UNIVERSITY OF ILLINOIS-URBANA



3 0112 050511341