

VTT Technical Research Centre of Finland

A Full Ka-band Highly Linear Efficient GaN-on-Si Resistive Mixer

Parveg, Dristy; Varonen, Mikko; Kantanen, Mikko; Pusa, Jehki

Published in:
2021 IEEE MTT-S International Microwave Symposium, IMS 2021

DOI:
[10.1109/IMS19712.2021.9574822](https://doi.org/10.1109/IMS19712.2021.9574822)

Published: 07/06/2021

Document Version
Peer reviewed version

[Link to publication](#)

Please cite the original version:

Parveg, D., Varonen, M., Kantanen, M., & Pusa, J. (2021). A Full Ka-band Highly Linear Efficient GaN-on-Si Resistive Mixer. In *2021 IEEE MTT-S International Microwave Symposium, IMS 2021* (pp. 645-648). IEEE Institute of Electrical and Electronic Engineers. IEEE MTT-S International Microwave Symposium <https://doi.org/10.1109/IMS19712.2021.9574822>



VTT
<http://www.vtt.fi>
P.O. box 1000FI-02044 VTT
Finland

By using VTT's Research Information Portal you are bound by the following Terms & Conditions.

I have read and I understand the following statement:

This document is protected by copyright and other intellectual property rights, and duplication or sale of all or part of any of this document is not permitted, except duplication for research use or educational purposes in electronic or print form. You must obtain permission for any other use. Electronic or print copies may not be offered for sale.

A Full Ka -band Highly Linear Efficient GaN-on-Si Resistive Mixer

D. Parveg^{#1}, M. Varonen[#], M. Kantanen[#], J. Pusa[#]

[#] VTT Technical Research Centre of Finland, Espoo, Finland

¹dristy.parveg@vtt.fi

Abstract— In this paper, we present a highly linear balanced IQ resistive mixer implemented in a 100-nm GaN HEMT on a silicon substrate that covers the whole Ka -band. The mixer achieves an input third-order intercept point (IIP3) of 30 dBm with only 10.5 dBm of LO input power at 35 GHz which means a record linear efficiency of 20 dB. The Measured 1-dB input compression point was 15 dBm at 34 GHz. The mixer shows a better than 10 dB conversion loss over the entire Ka -band.

Keywords— FMCW, GaN, GaN-on-Silicon, HEMT, high-linear, IIP3, Ka -band, mixer, MMICs, passive mixer, resistive mixer, radar.

I. INTRODUCTION

In a typical Frequency modulated continuous wave (FMCW) radar operation, a linear frequency-modulated continuous wave signal is amplified by the power amplifier (PA) and transmitted by the antenna. Any object in the vicinity of the radar range reflects the transmitted signal and received by the receiving antenna. The received signal is amplified by the low-noise amplifier (LNA) and mixes with the local oscillator (LO) signal to produce the beat-frequency or the intermediate frequency (IF). Since the FMCW radar continuously transmits and receives the signal, the upper detection range of the radar is sensitive to the transmit power level because a high transmit power may saturate the receiver. Therefore, to increase the radar detection range, the radar receiver path must be highly linear.

Gallium nitride (GaN) based technologies have shown their potential to achieve a level of linearity that used to seem impossible. Recent publications of GaN technology based low-noise amplifiers [1]–[3] and mixers [4]–[6] have proven their capability. However, the mixers usually require high LO drive levels that only slightly lower than the input third-order intercept point (IIP3). The IIP3 is a key linearity-performance criterion of mixer linearity.

This work aims to verify the feasibility of a GaN-on-Si resistive mixer for a Ka -band radar applications, aiming to achieve state-of-the-art linear efficiency (the difference between the IIP3 value and the required LO drive level) while keeping the lowest possible conversion loss.

II. MIXER DESIGN AND CIRCUIT REALIZATION

In this work, we have designed a single balanced IQ resistive mixer for a receiver that can handle > 15 dBm of input power with an LO power lower than 10 dBm. A simplified schematic of the implemented mixer is shown in Fig. 1(a). The IQ mixer consists of two singly balanced unit mixers. The spiral transmission line balun provides a 180°

phase shift for the transistor gates of a unit mixer. Since the LO drives the two gates in a balanced (180 degree) mode, the IF signals at the drains are 180 degrees out of phase. The off-chip baluns are required to combine the IF power. The transistor drains of each singly balanced mixer are connected together with the small valued capacitors as shown in Fig. 1 (b). The connection points are virtual grounds for the fundamental LO signal and its odd harmonics, and open circuits for the IF signals. In the IF line, the short-circuited shunt stubs are $\lambda/4$ at RF frequency providing an open circuit at RF and a short circuit at the even harmonics of the LO and RF. The RF signal is fed through a Lange coupler which provides the required 0° and 90° signals for the IQ operation.

The key design parameters for a resistive mixer are device size, gate-bias voltage, LO drive level, the impedance at RF port (Z_{RF}), and impedance at LO port (Z_{LO}). Our extensive parameterized simulations show that the Z_{LO} has a major impact on the mixer linearity and other parameters have an impact on the conversion gain (CG). Of course, the LO drive level and the gate-biasing voltage have the most significant impact on the linearity but these parameters can be controlled externally. In this work, we have particularly focused on

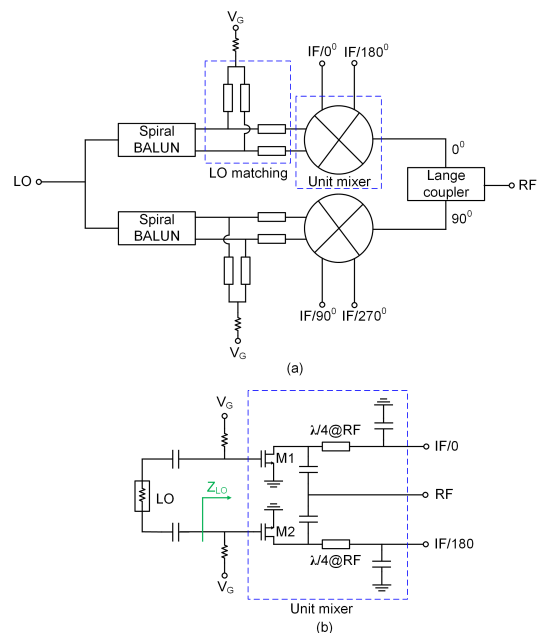

Fig. 1. (a) A simplified schematic of the implemented single-balanced IQ mixer. (b) A test bench for obtaining the optimum LO impedance (Z_{LO}) from the unit mixer.

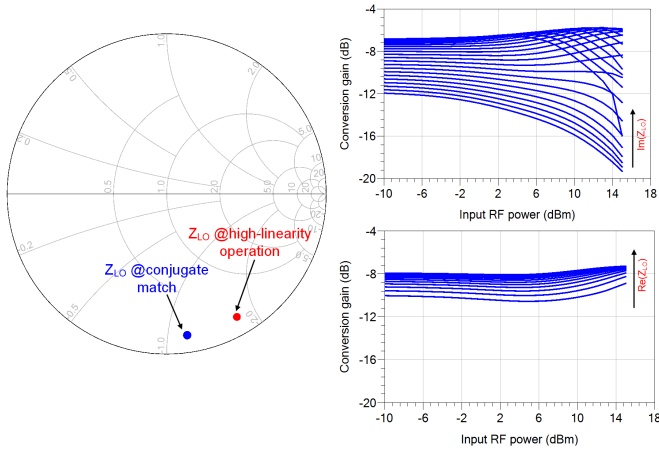

Fig. 2. On the left side, the large-signal matching Z_{LO} and the optimum Z_{LO} for improving linearity at the design frequency are shown on a smith chart. On the right side, the imaginary and the real part of the Z_{LO} are varied for 10 to 120 and 4 to 12, respectively and observed the linear performance of the mixer.

determining the optimum Z_{LO} that can provide better linearity, and also a wideband matching circuitry for translating the LO power to the gates of the mixers efficiently.

A. Optimum Z_{LO}

To find out the optimum LO impedance (Z_{LO}), we have worked with the unit mixer and created a test-bench as shown in Fig. 1(b). Initially, the device size and the gate-biasing voltage were optimized for the lower conversion loss. The large-signal Z_{LO} is calculated from the large-signal input voltage and current. By terminating the LO port with the conjugate impedance of the mixing devices at the design frequency gives already a fairly good linear performance which can be used as a starting point for the LO port matching. However, a further improvement of linearity is possible by varying the imaginary part of the Z_{LO} . We have varied the real and imaginary parts of the Z_{LO} , and keep track of the linearity performance of the mixer. The simulation results reveal that the real part has minimal impact on the mixer performance, however, the imaginary part has a significant impact on both the conversion gain and the linearity of the mixer as shown in Fig. 2.

B. LO port matching

A spiral transmission line balun is a wideband balun, however, direct wideband matching using the balun to the desired Z_{LO} is inefficient. Thus a novel wideband matching circuitry of translating the 50Ω input LO power efficiently to the gates of the unit mixers was proposed in [7] and adopted in this work. A coupled series line (L_{Line}) together with a short-circuited coupled line stub (L_{Stub}) are used to transform the low Z_{LO} to the high real impedance as shown in 3. This transformation simplifies the impedance matching to the LO-port by a $\lambda/4$ transmission line balun. The use of L_{Stub} also reduce the coupling requirements of the spiral balun thus an overall efficient and wideband LO matching network is designed.

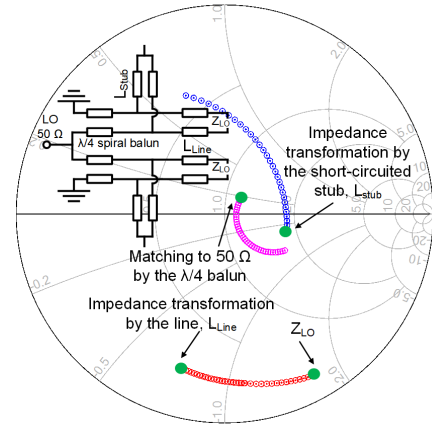

Fig. 3. A step-by-step impedance transformations from the Z_{LO} to the LO port are depicted on a smith chart.

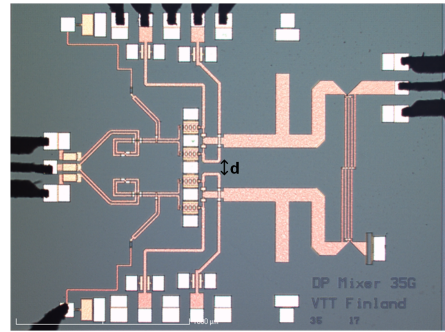

Fig. 4. A Micrograph of the designed IQ single-balanced resistive mixer.

C. MMIC realization

The MMIC is implemented on a commercially available 100-nm GaN-on-Si process (D01GH) from OMMIC. The unit cell mixer consists of two devices with a geometry of $2 \times 100 \mu\text{m}$. The device's large-signal model provided by the foundry is used for all the analysis and the design. The process has two metal layers and the backside of the chip has a solid metal acting as the ground plane. The process has MIM capacitors and resistors. Microstrip lines are used to implement the transmission lines and in design of the passives. The designed mixer occupies a chip area of 5.2 mm^2 . A micrograph of the MMIC is shown in Fig. 4.

III. MEASURED MIXER PERFORMANCE

On-wafer measurements were carried out to characterize the mixer performance namely the conversion gain, IF and RF bandwidth, required LO drive level, and linearity (P1dB/IIP3). We have used an Agilent PNA-X N5245A vector network analyzer (VNA) to measure the mixer. An external synthesizer for the LO signal and a pre-amplifier at the RF path were used to provide the required power to the mixer. The output power of the VNA was calibrated by a power meter. The mixer gates were biased at -1.7 V for optimum mixing performance.

The conversion gain (CG), 1-dB input compression point (P1dB), and the third-order intercept point (IIP3) were measured as a function of the LO power. As can be seen

Table 1. State-of-the-art Performance of the *Ka*-band Passive Mixers.

Ref	Topology	Technology	RF (GHz)	CL (dB)	P1dB (dBm)	IIP3 (dBm)	LO power (dBm)	Linear efficiency (dB)
[4]	Single balanced	GaN-Si 100-nm	26 – 31	11 – 12.5	11	22	10	12
[6]	Single balanced	GaN-SiC 150-nm	26 – 30	11 – 12	10	20	10	10
[5]	Single balanced	D-GaAs 150-nm	27	8.1	21.7	35	19.6	15.4
		D-GaN-SiC 150-nm		8.3	19.8	34.3	20.7	13.6
		E-GaAs 150-nm		9	22	37.5	21.6	15.9
This work	IQ Single balanced	GaN-Si 100-nm	26 – 40	11 – 8	11 – 15.5	22 – 30.5	10.5	11.5 – 20

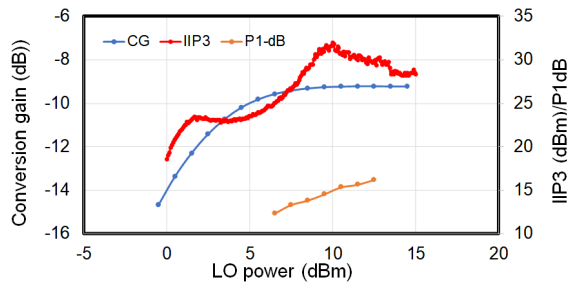

Fig. 5. Measured CG, P1dB, and IIP3 as a function of LO-power at a fixed LO and RF frequency of 33.3 GHz and 33.5 GHz, respectively.

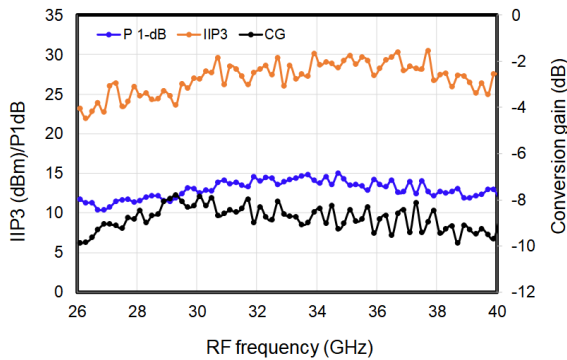

Fig. 6. Measured CG, P1dB, and IIP3 responses at a fixed IF frequency of 200 MHz when the LO was swept from 25.8 to 39.8 GHz with a 10.5 dBm of LO power.

from Fig. 5 that with a 10.5 dBm LO power a better than 10 dB CG is obtained. The P1dB and the IIP3 are measured 15 dBm and 30 dBm respectively with only 10.5 dBm of LO power. Therefore, the measured linear efficiency, which is the difference between IIP3 and LO drive level [8] is about 20. The CG, P1dB, and IIP3 at a fixed IF frequency of 200 MHz is presented in Fig. 6. The RF frequency was varied over the full *Ka*-band (26 – 40 GHz) and a CG of -9 dB, a P1dB of 15 dBm, and an average IIP3 of 28 dBm are measured around 32 – 36 GHz which was the center frequency of the design. Measured conversion gain over IF frequency sweep at a fixed 33.3 GHz of LO frequency is illustrated in Fig. 7. The RF was swept from 27.5 to 39.4 GHz using a 10.5 dBm of LO power. A wide 6 GHz IF frequency tuning range is obtained

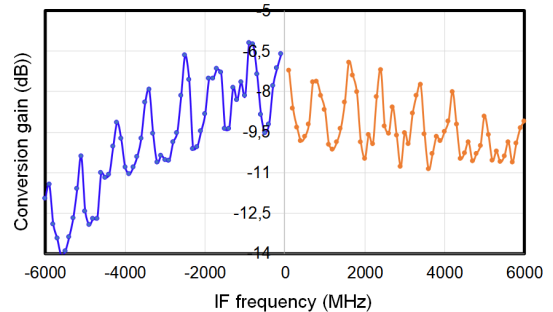

Fig. 7. Measured CG at a fixed LO frequency of 33.3 GHz when the RF was swept from 27.5 to 39.4 GHz using a 10.5 dBm of LO power.

at both the upper and the lower side. The observed ripple in the measurement repeats every 800 MHz which indicates the use of a long IF cable that is producing standing waves.

We have also measured the IQ balance which is around 13 dB, whereas the simulations show better than 25 dB over the *Ka*-band. A further investigation reveals that the IF lines from the two-unit mixers were so closed that (less than the substrate thickness) a potential coupling was destroying the IQ balance. By increasing the distance d as shown in Fig. 4, a good IQ performance is possible to achieve.

IV. CONCLUSION

This work describes the design of a full *Ka*-band GaN-on-Si resistive mixer. Measured results are compared with the other published *Ka*-band GaN MMIC mixers in Table 1. The presented mixer shows a wideband RF and IF performance and a record linear efficiency. To the best of the author's knowledge, this is the highest reported linear efficiency for any *Ka*-band mixer. Furthermore, the presented results demonstrate the potential of utilizing a 100-nm GaN HEMT on silicon substrate technology for highly linear and wideband resistive mixer design at *Ka*-band frequencies.

ACKNOWLEDGMENT

This work was supported through the Academy of Finland project MIDERI (decision no. 310234) and the Business Finland project LuxTurrim5G+ (decision no. 2604/31/2019). The measurements were carried out at Millilab, the Millimeter Wave Laboratory of Finland, and the external laboratory of the European Space Agency (ESA).

REFERENCES

- [1] D. Parveg, M. Varonen, and M. Kantanen, "A full ka-band gan-on-si low-noise amplifier," in *2020 50th European Microwave Conference (EuMC)*, 2021, pp. 1015–1018.
- [2] L. Pace, S. Colangeli, W. Ciccognani, P. E. Longhi, E. Limiti, R. Leblanc, M. Feudale, and F. Vitobello, "Design and validation of 100 nm gan-on-si ka-band lna based on custom noise and small signal models," *Electronics*, vol. 9, no. 1, 2020.
- [3] E. M. Suijker, M. Rodenburg, J. A. Hoogland, M. van Heijningen, M. Seelmann-Eggebert, R. Quay, P. Bruckner, and F. E. van Vliet, "Robust algan/gan low noise amplifier mmics for c-, ku- and ka-band space applications," in *2009 Annual IEEE Compound Semiconductor Integrated Circuit Symposium*, 2009, pp. 1–4.
- [4] A. De Padova, P. E. Longhi, S. Colangeli, W. Ciccognani, and E. Limiti, "Design of a gan-on-si single-balanced resistive mixer for ka-band satcom," *IEEE Microwave and Wireless Components Letters*, vol. 29, no. 1, pp. 56–58, 2019.
- [5] M. S. Clements, A. Pham, J. S. Sacks, B. C. Henderson, and S. E. Avery, "Comparison of highly linear resistive mixers in depletion and enhancement mode gaas and gan pHEMTs at ka band," in *2018 IEEE/MTT-S International Microwave Symposium - IMS*, 2018, pp. 435–438.
- [6] M. Do, M. Seelmann-Eggebert, R. Quay, D. Langrez, and J. Cazaux, "Algan/gan mixer mmics, and rf front-end receivers for c-, ku-, and ka-band space applications," in *The 5th European Microwave Integrated Circuits Conference*, 2010, pp. 57–60.
- [7] D. Parveg, M. Varonen, M. Kärkkäinen, and K. A. I. Halonen, "Design of mixers for a 130-ghz transceiver in 28-nm cmos," in *Proceedings of the 2013 9th Conference on Ph.D. Research in Microelectronics and Electronics (PRIME)*, 2013, pp. 77–80.
- [8] C. Trantanella, "Reaching new levels of linearity in passive mixers with gan technology," Custom MMIC/Qorvo, Tech. Rep., Apr. 2017.