



## A Holocene relative sea-level database for the Baltic Sea

Alar Rosentau<sup>a,\*</sup>, Volker Klemann<sup>b</sup>, Ole Bennike<sup>c</sup>, Holger Steffen<sup>d</sup>, Jasmin Wehr<sup>e</sup>, Milena Latinović<sup>b</sup>, Meike Bagge<sup>b</sup>, Antti Ojala<sup>f,g</sup>, Mikael Berglund<sup>h</sup>, Gustaf Peterson Becher<sup>i,j</sup>, Kristian Schoning<sup>i</sup>, Anton Hansson<sup>k</sup>, Lars Nielsen<sup>l</sup>, Lars B. Clemmensen<sup>l</sup>, Mikkel U. Hede<sup>l,m</sup>, Aart Kroon<sup>l</sup>, Morten Pejrup<sup>l</sup>, Lasse Sander<sup>l,n</sup>, Karl Stattegger<sup>o</sup>, Klaus Schwarzer<sup>o</sup>, Reinhard Lampe<sup>p</sup>, Matthias Lampe<sup>q</sup>, Szymon Uścińowicz<sup>r</sup>, Albertas Bitinas<sup>s</sup>, Ieva Grudzinska<sup>t</sup>, Jüri Vassiljev<sup>u</sup>, Triine Nirgi<sup>a</sup>, Yuriy Kublitskiy<sup>v</sup>, Dmitry Subetto<sup>v,w,x</sup>

<sup>a</sup> Institute of Ecology and Earth Sciences, University of Tartu, 51014, Tartu, Estonia

<sup>b</sup> Helmholtz Centre Potsdam, GFZ German Research Centre for Geosciences, Telegrafenberg, 14473 Potsdam, Germany

<sup>c</sup> Geological Survey of Denmark and Greenland, Øster Voldgade 10, 1350, Copenhagen K, Denmark

<sup>d</sup> Lantmäteriet, Geodata Division, Lantmäterigatan 2C, 80182 Gävle, Sweden

<sup>e</sup> Institute of Geography, Friedrich-Schiller University, Jena, Germany

<sup>f</sup> Geological Survey of Finland, P.O. Box 96, 02151, Espoo, Finland

<sup>g</sup> Department of Geography and Geology, University of Turku, FI-20014, Turku, Finland

<sup>h</sup> Office of Education and Research, Dalarna University, 79188, Falun, Sweden

<sup>i</sup> Geological Survey of Sweden, Box 670, 7512819, Uppsala, Sweden

<sup>j</sup> Department of Earth Sciences, Gothenburg University, Box 460, 40530, Gothenburg, Sweden

<sup>k</sup> Department of Geology, Lund University, Sölvegatan 12, Lund, 223 62, Sweden

<sup>l</sup> Department of Geosciences and Natural Resource Management, Faculty of Science, University of Copenhagen, Øster Voldgade 10, 1350, Copenhagen K, Denmark

<sup>m</sup> Now at: Tårnby Gymnasium og HF, Tejn Alle 5, 2770, Kastrup, Denmark

<sup>n</sup> Alfred-Wegener-Institute, Helmholtz Center for Polar and Marine Research, Wadden Sea Research Station, Hafensstraße 43, 25992, List/Sylt, Germany

<sup>o</sup> Institute of Geosciences, Kiel University, Olshausenstrasse 40, 24118, Kiel, Germany

<sup>p</sup> Institute of Geography and Geology, Greifswald University, 17487, Greifswald, Germany

<sup>q</sup> Institut biota GmbH, 18246, Bützow, Germany

<sup>r</sup> Polish Geological Institute - National Research Institute, Branch of Marine Geology, Kościarska 5, 80-328, Gdańsk, Poland

<sup>s</sup> Nature Research Centre, Akademijos Str. 2, LT-08412, Vilnius, Lithuania

<sup>t</sup> Institute of Biology, University of Latvia, Miera iela 3, Salaspils, 2169, Latvia

<sup>u</sup> Institute of Geology, Tallinn University of Technology, Ehitajate tee 5, 1908645, Tallinn, Estonia

<sup>v</sup> Herzen State Pedagogical University of Russia, Moika emb. 48, 191186, Saint-Petersburg, Russia

<sup>w</sup> Institute for Water and Environmental Problems, Siberian Branch of the Russian Academy of Sciences, Barnaul, Molodezhnaya street 1, 6560386, Russia

<sup>x</sup> Immanuel Kant Baltic Federal University, A. Nevsky street 14, Kaliningrad, 236016, Russia

### ARTICLE INFO

#### Article history:

Received 7 September 2020

Received in revised form

21 June 2021

Accepted 27 June 2021

Available online 20 July 2021

Handling Editor: I. Hendy

#### Keywords:

Baltic sea

Sea-level indicator

Relative sea level

HOLSEA

### ABSTRACT

We present a compilation and analysis of 1099 Holocene relative shore-level (RSL) indicators located around the Baltic Sea including 867 relative sea-level data points and 232 data points from the Ancylus Lake and the following transitional phase. The spatial distribution covers the Baltic Sea and near-coastal areas fairly well, but some gaps remain mainly in Sweden. RSL data follow the standardized HOLSEA format and, thus, are ready for spatially comprehensive applications in, e.g., glacial isostatic adjustment (GIA) modelling. We apply a SQL database system to store the nationally provided data sets in their individual form and to map the different input into the HOLSEA format as the information content of the individual data sets from the Baltic Sea area differs. About 80% of the RSL data is related to the last marine stage in Baltic Sea history after 8.5 ka BP (thousand years before present). These samples are grouped according to their dominant RSL tendencies into three clusters: regions with negative, positive and complex (transitional) RSL tendencies. Overall, regions with isostatic uplift driven negative tendencies dominate and show regression in the Baltic Sea basin during the last marine stage. Shifts from positive to negative tendencies in RSL data from transitional regions show a mid-Holocene highstand around 7.5

\* Corresponding author.

E-mail address: [alar.rosentau@ut.ee](mailto:alar.rosentau@ut.ee) (A. Rosentau).

Glacial isostatic adjustment  
Ice history model  
Mapping function  
PostgreSQL

–6.5 ka BP which is consistent with the end of the final melting of the Laurentide Ice Sheet. Comparisons of RSL data with GIA predictions including global ICE-5G and ICE-6G\_C ice histories show good fit with RSL data from the regions with negative tendencies, whereas in the transitional areas in the eastern Baltic, predictions for the mid-Holocene clearly overestimate the RSL and fail to recover the mid-Holocene RSL highstand derived from the proxy reconstructions. These results motivate improvements of ice-sheet and Earth-structure models and show the potential and benefits of the new compilation for future studies.

© 2021 The Authors. Published by Elsevier Ltd. This is an open access article under the CC BY license (<http://creativecommons.org/licenses/by/4.0/>).

## 1. Introduction

Advance and retreat of the Scandinavian Ice Sheet caused significant mass redistributions in the Baltic Sea Basin (BSB) and surrounding areas. The retreat resulted in glacial isostatic adjustment (GIA) and variable relative shore- (sea-) level (RSL) changes in tens or even hundreds of metres after the last deglaciation. RSL records from the BSB area are therefore the key constraint to understand glacial isostasy and mantle viscosity (Lambeck et al., 1998). In both fields, GIA models are generally parametrised by a lithosphere of constant thickness and a stratified mantle with Maxwell rheology. The model's fit to shore-level data serves as the major constraint in such modelling as the data mirrors surface deformations manifested in RSL change during the last 20,000 years (Wu et al., 2013). Hence, the inference of the ice-load history (which to date always needs some GIA model information), the lithospheric thickness and the mantle viscosity structure depends strongly on the quality of the sea-level data used (Steffen et al., 2014).

The complex history of the BSB with up-dammed lake phases (Baltic Ice Lake and Ancylus Lake) and marine phases (Yoldia Sea and Littorina Sea) challenges the use of RSL records in GIA modelling. Standardised and uniform RSL databases covering the whole BSB were compiled by Lambeck et al. (1998, but data were not published) and Tushingham and Peltier (1992, 1993). The datasets included sea- and lake-level records and were used in global GIA modelling. Since Lambeck et al. (1998) several regional and local datasets with sea-level index points (SLIPs) or limiting data points have been published from areas where high-resolution RSL data were not previously available, especially from the eastern and southern BSB areas (Miettinen et al., 2007a,b; Rosentau et al., 2013; Grudzinska et al., 2017; Muru et al., 2017; Žulkus and Girinninkas, 2012; Nirgi et al., 2020).

RSL highstands were well known already at the beginning of the last century, while high-quality data about sea-level lowstands have been available only in the recent past. Studies of underwater landscapes, especially recent research into rooted tree stumps (Hansson et al., 2018; Rosentau et al., 2017; Žulkus and Girinninkas, 2012), Mesolithic kitchen middens and refuse layers of the various coastal sites and shallow-water fishing constructions (Groß et al., 2018; Hansson et al., 2019; Astrup, 2019) provide new fresh means for understanding the interplay between sea-level rise and GIA during the mid-Holocene.

Here we compile and present a publicly available Holocene RSL database for the Baltic Sea basin and the Kattegat area. This includes SLIPs and upper and lower limiting data points from the different parts of the BSB, including well-known data points from the regions of the highest postglacial uplift in the Fennoscandian Shield area, but also filling some of the important data gaps related to offshore and eastern Baltic Sea areas. We discuss the indicative meaning of multiple RSL indicators including isolation basins, coastal peat layers, raised shorelines and archaeological coastal settlement layers. Lake-level indicators from the Ancylus Lake (10.7–9.8 ka BP) and the following transitional phase - Initial

Littorina Sea (9.8–8.5 ka BP) - are also presented in the database. Finally, we analyse the spatial variability of the data and compare the observations with selected GIA model predictions. The database is based on the standardized HOLSEA format (Hijma et al., 2015) covering all Baltic Sea geographic regions with different postglacial uplift histories. It also provides possibilities for direct data comparisons with other regions within the Eurasian Ice Sheet complex, including datasets from Britain and Ireland (Shennan et al., 2018), the Atlantic coast from France to Portugal (Garcia-Artola et al., 2018), the Netherlands (Hijma and Cohen, 2019), the Russian Arctic (Baranskaya et al., 2018) and further regions on the globe (Khan et al., 2019).

## 2. Regional setting

The Baltic Sea is a semi-enclosed intra-continental and almost tide-less sea with a total area of about 392,978 km<sup>2</sup> (without the Kattegat), and with a catchment area about four times larger than the area of the Baltic Sea itself. The transition zone between the Baltic Sea and the North Sea, and thus between brackish and oceanic water masses, is the Kattegat (22,287 km<sup>2</sup>), which is sometimes included as part of the Baltic Sea (Leppäranta and Myrberg, 2009). The present-day tidal range is 15–30 cm in the Danish straits, 2–5 cm in most of the Baltic Sea, up to 10 cm in the northern Gulf of Finland (Leppäranta and Myrberg, 2009) and 17–19 cm in the easternmost part of the Gulf of Finland (Medvedev et al., 2013).

The BSB area experienced several glaciation events related to the major climatic shifts during the Last Glacial Period (Marine Isotope Stages (MIS) 4 to 2 (Batchelor et al., 2019). The Last Glacial Maximum (LGM) occurred during MIS 2, at around 20 ka BP and represented the coldest phase of the last glacial–interglacial cycle with the largest ice volume and the most extensive areal coverage. The maximum ice thickness was around 3000 m in the area of the fastest uplift along the western coast of the Bothnian Sea (Kierulf et al., 2021).

Since the LGM, the BSB has undergone a number of lake and sea stages (for details see Andrén et al., 2011), starting with the Baltic Ice Lake (BIL). This freshwater body lasted from about 16 ka BP (Houmark-Nielsen and Kjær, 2003) to 11.7 ka BP and was formed by meltwater inflow from the retreating ice sheet in the north and by river discharge from the south and east (Fig. 1). It is assumed that during the initial stage of the BIL the lake level was approximately at ocean level and, then, increased relative to the latter. According to a study by Muschitiello et al. (2016), the first drainage of the BIL at the outlet of Mt. Billingen took place at 12.87 ka BP, lowering the BIL by ca 5–10 m in a few years (Björck, 1995). Evidence from the Arkona Basin in the southern Baltic indicates a more pronounced lowering of the shore level of ca 20 m (Bennike and Jensen, 2013). During the cold Younger Dryas the ice margin re-advanced and the BIL was again dammed by the ice sheet (Björck, 2008). Soon after, the ice sheet started to retreat from the Younger Dryas position (marked by distinctive ice-marginal formations, such as

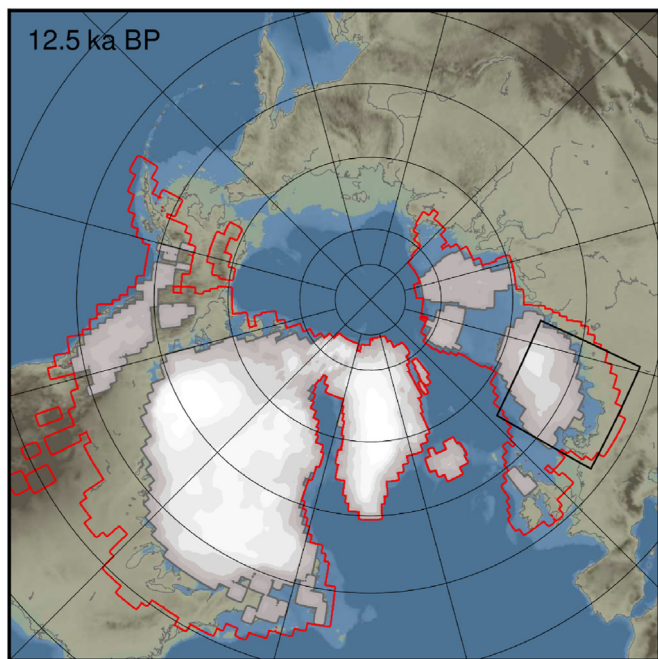

**Fig. 1.** Extent of ice sheets and palaeogeography in the Northern Hemisphere at about 12.5 ka BP according to the ICE-5G model (Peltier, 2004) with location of the study area and the ice-dammed Baltic Ice Lake in the Baltic Sea Basin area. Red contours marks ice sheet extents during the last glacial maximum around 20–21 ka BP. Palaeotopography is reconstructed with the same ice-sheet model and the VM2 earth model associated with ICE-5G model. (For interpretation of the references to colour in this figure legend, the reader is referred to the Web version of this article.)

Salpausselkäs in Finland), and the water level of the BIL suddenly dropped within 1–2 years by ca 25 m just prior to 11.7 ka BP (Björck, 1995; Walker et al., 2009). During that stage the BIL has been connected to the sea via south-central Sweden, while southern Sweden has formed a peninsula connected to Denmark and Germany. The drop of water level marks the beginning of the next stage in the Baltic Sea history, the Yoldia Sea (YS) from 11.7 to 10.7 ka BP (Fig. 2A). It took about 400 years before saline water penetrated into the Baltic Basin, initiating the brackish phase of the YS which lasted from 11.3 to 11.1 ka BP (Andrén et al., 2002; Obrochta et al., 2017). Land uplift in south-central Sweden stopped the water inflow from the sea and the YS gradually turned into a freshwater lake. A rapid Ancylus Lake (AL) transgression has been documented in the southern Baltic. It started about 10.7 ka BP, reached a highstand ca 10.3 ka BP (Fig. 2B) and lasted until 9.8 ka BP (Björck, 2008; Hansson et al., 2018). The Ancylus Lake stage is characterised by a ‘tipping bathtub effect’ resulting in regionally varying shore-level signatures (Andrén et al., 2011). In the northern parts of the Baltic regression was seen. The highest lake level is marked by the AL beach in south-east Sweden and Gotland (Svensson, 1989, 1991), Latvia (Saarse et al., 2003) and Estonia (Nirgi et al., 2020). As land uplift was larger in the north than in the south and the lake level rose at the same time in general up to 10 m mean sea level, the southern coasts of the AL became inundated. At 10.2 ka BP, a new outlet formed via Mecklenburg Bay, Fehmarn Belt, and the Great Belt to the Kattegat (Bennike et al., 2004), which likely led to an initial lowering of the AL of about 5 m followed by a fluvial phase, the Dana River along the new outlet. At ca 9.8 ka BP, the lake level and the sea level balanced again, and saline water began to enter the lake (Andrén et al., 2000; Berglund et al., 2005). The river developed as the drainage pathway of the AL and several smaller lakes formed in the western Baltic Sea area towards the Kattegat and North Atlantic. But the magnitude of the AL level drop is

controversial. Thus Jensen et al. (1999) and Lemke et al. (1999) saw little evidence for erosion by the Dana River. The Littorina Sea (LS) transgression marks the most important stage of inundation associated with inflow of saline waters from the North Atlantic and finally shaping the present Baltic Sea south of the Scandinavian uplift region. This early Holocene transgression most likely progressed initially through the morphological depression of the Dana valley in the present-day Great Belt and Fehmarn Belt region (Björck, 2008; Feldens and Schwarzer, 2012). The Early Littorina Sea, Mastogloia Sea or Initial Littorina Sea (ILS), is a transitional phase from the AL to the LS from 9.8 to ca 8.5 ka BP with an almost freshwater character (Fig. 2C; Berglund et al., 2005). Rising sea level resulted in flooding of the southern Kattegat area around 9.3 ka BP (Bendixen et al., 2017) and adjusted with the lowering lake levels around 9.0 ka BP at approximately 30 m below sea level (b.s.l.). As a consequence of a further rising sea level during the final phase of deglaciation the riverine AL outflow from the Baltic Sea basin turned into a brackish-marine inflow from the North Atlantic passing the Great Belt and Fehmarn Belt depressions and flooding successively the areas above the 30 m b.s.l. (Ernst, 1974).

The timing of the transition from fresh to brackish water that marks the onset of the LS is not yet clearly determined and might have started in the northern Great Belt region around 9.0 ka BP and east of the Darß Sill after 8.5 ka BP (Andrén et al., 2011). The cause for the saline water inflow into the BSB is believed to be related to episodic melting of the Laurentide and Antarctic ice sheets (Andrén et al., 2011). However, since 8.5 ka BP a LS transgression has been recorded in many different locations around the BSB suggesting the onset of the last marine stage (Berglund et al., 2005; Lampe et al., 2011; Rosentau et al., 2013; Nirgi et al., 2020).

The end of the rapid melting of the Laurentide and Antarctic ice sheets resulted in a slow-down of RSL rise in the areas of near-zero uplift (Lampe et al., 2011) and the culmination of the mid-Holocene RSL highstand in the areas of the slow postglacial uplift around 7.5–6 ka BP (Fig. 2B; Yu et al., 2007; Rosentau et al., 2013). Brackish-marine diatom assemblages from the sediments of the Landsort deep suggest that the highest surface water salinities in the BSB occurred between 7.1–5.4 ka BP (van Wirdum et al., 2019), thus during the highstand or slightly later. The beginning of the late LS stage (ca 3.0 cal ka BP; Berglund et al., 2005) is identified by microfossils (Björck, 1995, 2008, 2008), but is not yet clearly defined based on results of many independent studies. According to Andrén et al. (2000) the late LS begins “where the siliceous microfossils assemblage that requires a more marine environment decreases”.

RSL changes and uplift patterns for the recent past have been recorded by tide gauge measurements complemented by repeated levelling (Ekman, 1996, 2009, 2009; Kakkuri, 1997; Douglas and Peltier, 2002). During the last decades continuous point positioning (time series of the coordinates) from permanent GNSS (Global Navigation Satellite System) networks has also become available for determinations of crustal movements with respect to the Earth centre of mass, e.g., within the BIFROST (Baseline Inferences from Fennoscandian Rebound Observations, Sea-level and Tectonics) project (Vestøl et al., 2019; Kierulf et al., 2021, Fig. 3).

### 3. Database compilation

The data sets compiled in this study cover all the geographic coastal regions of the Baltic Sea including the Kattegat area (Fig. 3) and extend over the entire Holocene period after the drainage of the Baltic Ice Lake at about 11.7 ka BP (Björck, 1995; Andrén et al., 2011). Altogether, 77 attributes of the HOLSEA database format (version 2019 at <https://www.holsea.org/>) were provided by different data providers of all circum-Baltic countries (Supplement 1). Country reports addressing specific issues related to the data



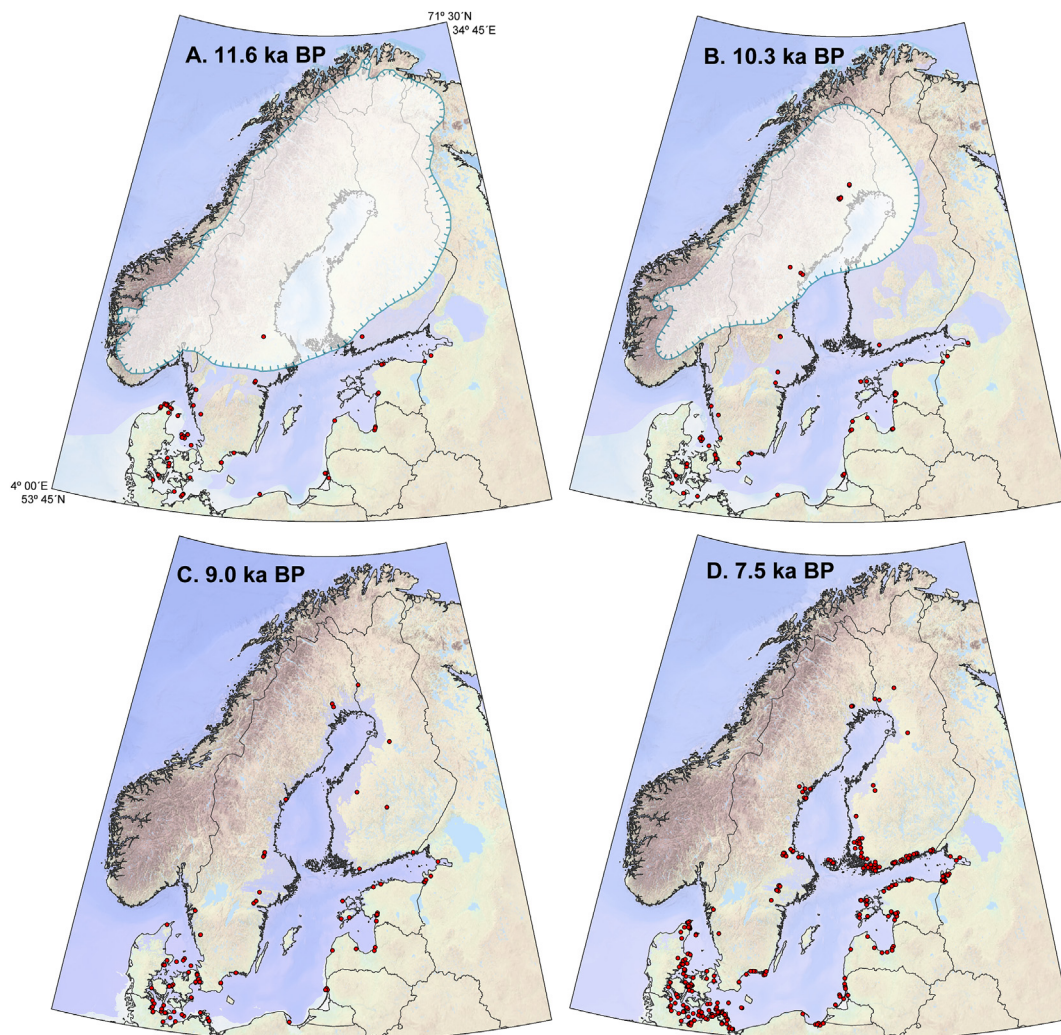

**Fig. 2.** Holocene development of the BSB with accepted RSL data points (red dots) from the (A) Yoldia Sea; (B) Ancylus Lake; (C) Initial Littorina Sea, and (D) Littorina Sea stages. The extent of the water bodies in BSB (semitransparent blue areas) is compiled according to data by [Andrén et al. \(2011\)](#), [Eronen et al. \(2001\)](#) and [Rosentau et al. \(2012\)](#). Topographic data from EMODnet Bathymetry. (For interpretation of the references to colour in this figure legend, the reader is referred to the Web version of this article.)

availability, collection, quality and sample's indicative meaning are provided in Supplement 2.

A few data sets were not provided in the HOLSEA data format of [Hijma et al. \(2015\)](#), see Supplement 2. The question arose how to deal with these data formats especially when it was not possible to transfer the provided data one-to-one into the HOLSEA workbook format. Accordingly, we decided to transfer all data sets into a Structured Query Language (SQL) database system (we chose PostgreSQL) where the original content of each table, usually a spread sheet, was imported and stored in separate relations or tables ([Fig. 4](#)). Relation-specific rules were defined in order to convert the data into the HOLSEA format, defined as views in the database system. The contributors were consulted about the rules. Finally, the union of all views was exported back into the HOLSEA workbook excel format. Advantage of this procedure is that we keep the original content and the transparency of the data conversion.

Radiocarbon data were partly re-calibrated after delivery. For this, we used the software OxCal, Version 4 developed by the Oxford Radiocarbon Accelerator Unit ([www.c14arch.ox.ac.uk/oxcal.html](http://www.c14arch.ox.ac.uk/oxcal.html)), which was installed locally and, so, could be implemented into the processing chain. Ahead of the data transfer into the HOLSEA worksheet, other information like 1-sigma ranges or

probability density functions determined by the software are provided in the database system. Luminescence ages were standardized to 1950 CE to be consistent with the radiocarbon ages (cal BP). This involves 38 samples in the database with age adjustments between 48 and 64 years.

## 4. Results and discussion

### 4.1. RSL indicators

The Holocene RSL database for the Baltic Sea holds 1099 accepted data points ([Fig. 5](#); [Appendix A](#)) of which 867 are sea-level data points and 232 are data points from the AL phase and the following transitional ILS phase from 10.7 to 8.5 ka BP ([Fig. 2](#)). From these, about one-third are SLIPs, represented by isolated lake basins, salt marsh deposits, basal peats, raised beach ridges and other indicators ([Fig. 5](#)). About one-third are terrestrial limiting points represented by freshwater peat deposits and Mesolithic and Neolithic cultural layers from the coastal zone. Marine limiting points include often near-shore marine and lagoon deposits from the isolation basin studies and other indicators. Their indicative meanings are summarized in [Table 1](#) and the water levels are

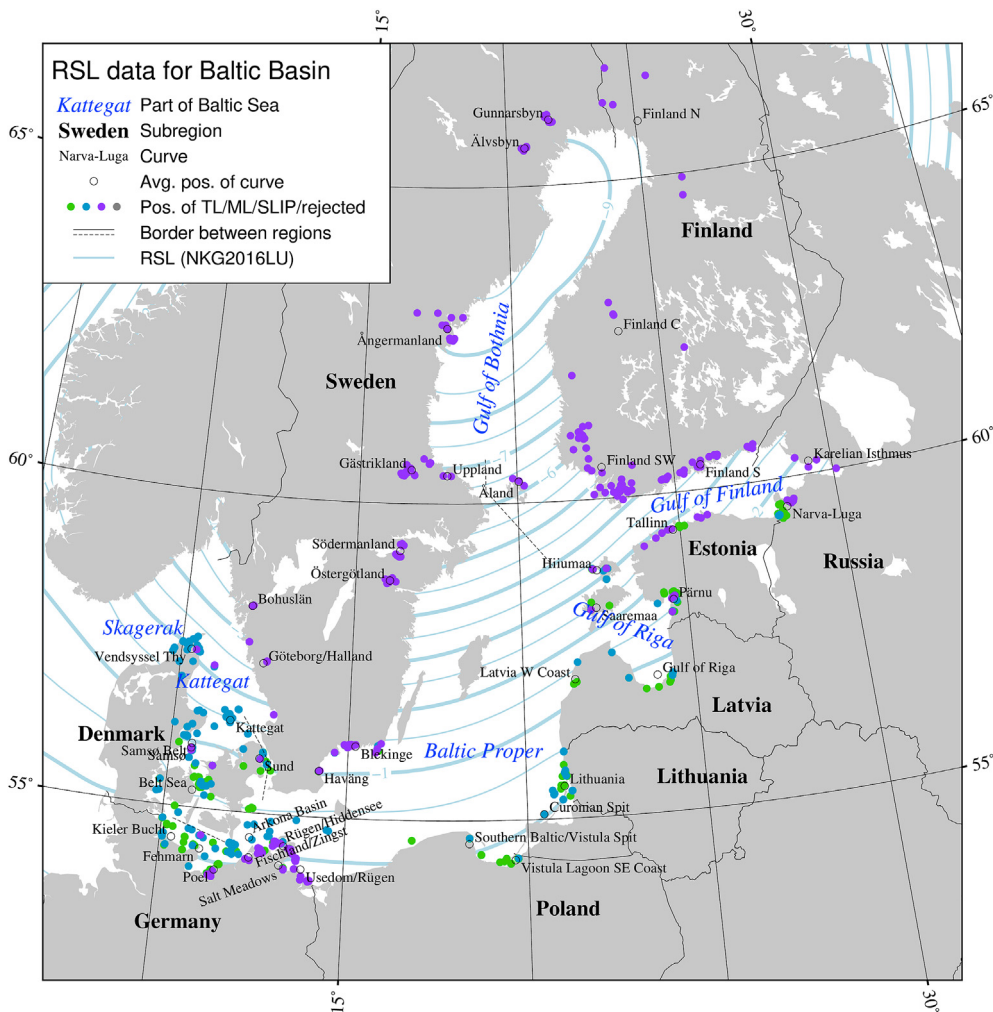

**Fig. 3.** Spatial distribution of the RSL data, including SLIPs and terrestrial and marine limiting points for the Baltic Sea compiled in the HOLSEA Baltic database together with numbers of 49 original regions or curves and geographic names. Blue contours represent the modern changes of RSL height in mm/yr according to the NKG2016U\_lev model (Vestøl et al., 2019). (For interpretation of the references to colour in this figure legend, the reader is referred to the Web version of this article.)

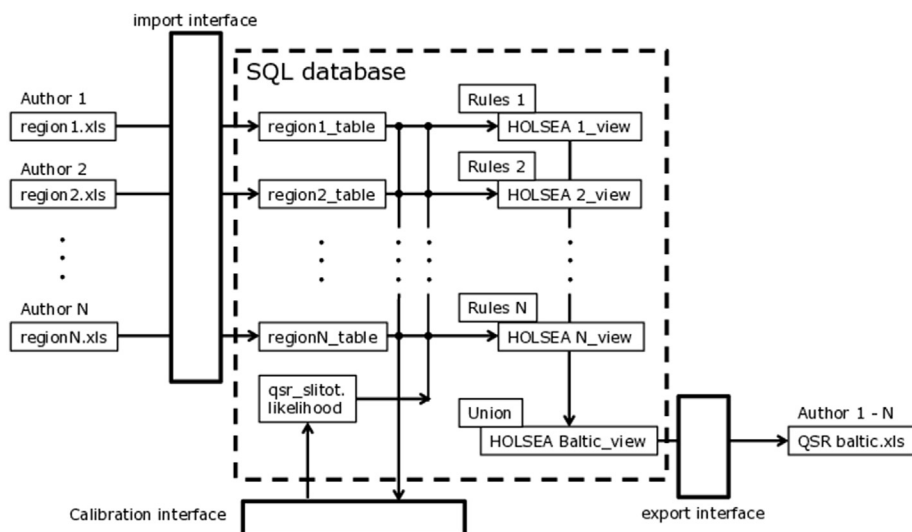

**Fig. 4.** Scheme of data processing applied to compile the Holocene RSL database for the Baltic Sea.

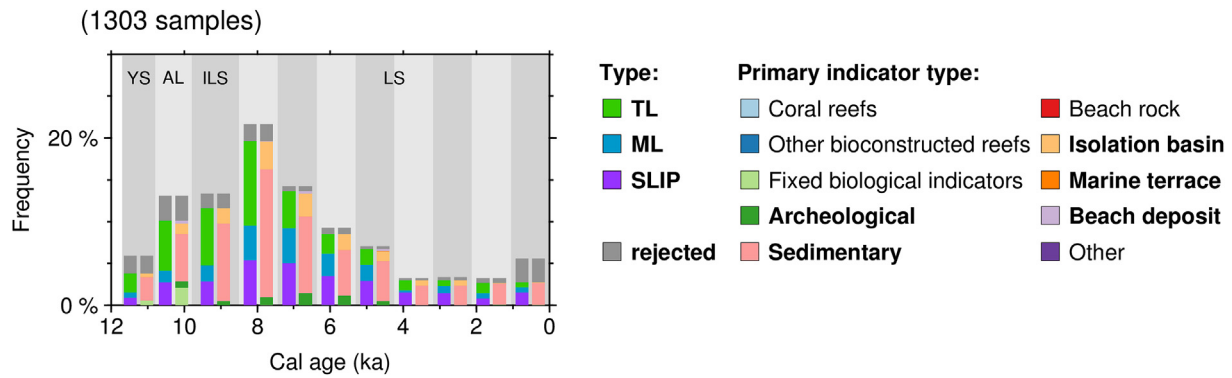

**Fig. 5.** Frequency distribution, in ~1000 years intervals, of SLIPs, limiting and rejected data points in the Holocene RSL database for the Baltic Sea. The Yoldia Sea (YS), Ancylus Lake (AL) and Initial Littorina Sea (ILS) stages are separated from the Littorina Sea stage, which is split into 8 intervals of ~1000 years. During the AL stage, 108 from the 152 samples are located in the central Baltic basin and cannot be used for sea level reconstruction. From the list of primary indicator types provided in the HOLSEA database format only those marked in bold are considered.

related to European mean sea level (MSL) based on Amsterdam zero (Normaal Amsterdams Peil, NAP). As the tidal range in the BSB is very small and clearly below the mean significant wave heights (Tuomi et al., 2011) the SLIPs in the database are not corrected for tidal effects.

AL and ILS index points are represented by isolated lake basins, submerged tree stumps and other indicators (Table 1). According to different authors the water level in the AL was up to 10–20 m above the Atlantic sea-level (Bennike and Jensen, 2013; Rosentau et al., 2013; Hansson et al., 2018) while the ILS water level was close to the Atlantic level (Andrén et al., 2011).

The largest number of RSL data including SLIPs are from the time period between 8.0 and 6.0 ka BP, and are associated with the research interest to study the changes during the mid-Holocene RSL rise (Fig. 5). The Late Holocene is rather poorly represented in the dataset and only few data points are available for the last 2 ka BP. The rejected 204 data points, not used in further analyses, are also included in the database, thus the total number of the points in the Baltic data set is 1303 (Appendix A). The largest number of rejected data is related to raised beach ridges, which can be used as SLIPs if their chronologies can be established. AL and ILS lower (marine) limiting points were also rejected as they can form either

**Table 1**

Summary of the indicative meanings used to estimate the relative elevation of the SLIPs and limiting points for the database. Indicative ranges are relative to mean sea level (MSL) in respect to Amsterdam zero.

Sample Type	Evidence	Indicative range relative to MSL
<b>Index points</b>		
Isolation basins	Stage of isolation determined from lithology, geochemistry, loss-on-ignition and diatom assemblages and sometimes by other microfossil evidences	MSL ± (0.2 m–0.5 m)
Submerged tree stumps	<i>In situ</i> tree stumps that died during marine transgression (Hansson, 2018)	up to 2.5 m above MSL ± 0.5 m
Highest shorelines, beach and storm ridges	Foot of the beach ridges and other coastal landforms with luminescence or radiocarbon ages from the same or neighbouring sites	typically MSL ± 1 m
Beach to upper shoreface contacts	Sandy to gravelly raised beach ridges with downlap points marking transition from beachface to upper shoreface (Hede et al., 2015)	MSL ± 0.5 m
Salt marshes	Salt marsh peat	up to 0.3 m above MSL
Fen peat to brackish water sediment transitions	Intercalated fen peat with brackish-water sediments (gyttja) on top	MSL ± 0.5m
<b>Marine limiting (ML) points</b>		
Marine and lagoonal deposits	Marine and lagoonal deposits from isolation basin sediments	below MSL
Prehistoric fishing constructions	Prehistoric fishing constructions in coastal lagoons and bays	below MSL
Offshore deposits with terrestrial macrofossils		below MSL
<b>Terrestrial limiting (TL) points</b>		
Freshwater peat	Freshwater peat or wood that do not show direct relationship with sea-level	above MSL
Archaeological cultural layers	Cultural layers of Mesolithic and Neolithic sites on the coast	above MSL
<b>Ancylus Lake index points (10.7–9.8 ka BP)</b>		
Isolation basins	Stage of isolation determined from lithology, geochemistry, loss-on-ignition and diatom assemblages and sometimes by other microfossil evidences	AL level ±(0.2 m–0.5 m)
Highest shorelines, beach and storm ridges	Foot of the beach ridges and other coastal landforms with luminescence or radiocarbon ages from the same or neighbouring sites	AL level ± 1 m
Submerged tree stumps	<i>In situ</i> tree stumps that died during marine transgression (Hansson, 2018)	up to 2.5 m above AL level ± 0.5 m
<b>Initial Littorina Sea index points (9.8–8.5 ka BP)</b>		
Isolation basins	Stage of isolation determined from lithology, geochemistry, loss-on-ignition and diatom assemblages and sometimes by other microfossil evidences	ILS level ±(0.2 m–0.5 m)
Submerged tree stumps	<i>In situ</i> tree stumps that died during marine transgression (Hansson, 2018)	up to 2.5 m above ILS level ± 0.5 m
Fen peat to brackish water sediment transition (transgressive contact)	Intercalated fen peat with brackish-water sediments (gyttja) on top	ILS level ± 0.5m



above or below MSL. Other rejected data include terrestrial and marine limiting data points, which form a cluster with very limited number of data points where the shore-level trends cannot be independently estimated with satisfactory confidence.

Overall, the accepted RSL indicators show the regional-scale variation and are further discussed following the developmental stages of the BSB (Fig. 2): 11.7–10.7 ka BP (YS); 10.7–9.8 ka BP (AL); 9.8–8.5 (ILS) and since 8.5 ka BP (LS). RSL data for the last marine stage (LS) were grouped according to their dominant RSL tendencies into three clusters: regions with negative, positive and complex (transitional) RSL tendencies (Fig. 6).

#### 4.2. RSL data and tendencies during the 11.7–10.7 ka BP (YS stage)

This group includes RSL data points from 16 original regions (SLIPs  $n = 13$ ; limiting points  $n = 84$ ) from the BSB and the Kattegat. No RSL data points are available from the Bothnian Bay and most of the Bothnian Sea regions because these areas were still covered by the Scandinavian Ice Sheet during the YS stage (Fig. 2A). About 95% of the RSL data are terrestrial and marine limiting points. Terrestrial limiting points include intercalated peat and gyttja deposits. Marine limiting points include sedimentary indicators with dates from marine shells or wood from marine or coastal sediments. A few SLIPs are coming from the isolated lake basins studies, from the sedimentary indicators and submerged rooted tree stumps.

The highest SLIPs are at an elevation of 118 m above the present day sea level (a.s.l.) in SW Finland (Fig. 7) while in the southern Baltic rooted pine stumps at Håväng in Sweden indicate an RSL of 22 m b.s.l. (Fig. 8) and rooted pine stumps at Lithuanian offshore even lower the RSL to around 34 m b.s.l. (Fig. 9). Coastal and marine deposits with marine shells from the Belt Sea region, which was separated from the BSB by a land bridge, suggest RSL levels of over 35 m b.s.l. (Fig. 9). RSL data points from SW Finland and Östergötland regions in Sweden suggest negative tendencies (Fig. 7) and RSL data points from Håväng and offshore Lithuania suggest positive RSL tendencies (Figs. 8 and 9) during the YS.

#### 4.3. RSL data and tendencies during the 10.7–9.8 ka BP (AL stage)

This group includes sea-level data points from the Kattegat, Halland (Sweden) and Göteborg (Gothenburg, Sweden) regions (SLIPs  $n = 3$ ; limiting points  $n = 7$ ) and lake-level data points of the up-dammed AL from the eight different regions (SLIPs  $n = 30$ ;

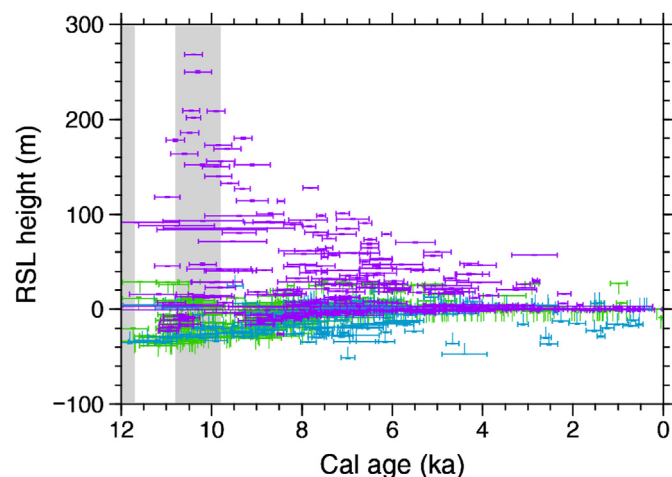

Fig. 6. Age-elevation plot of the Baltic relative sea-level (RSL) data with all accepted SLIPs (violet) and terrestrial (green) as marine (blue) limiting points. Grey zones mark Baltic lake stages. (For interpretation of the references to colour in this figure legend, the reader is referred to the Web version of this article.)

limiting points  $n = 75$ ).

Sea-level data points are represented by marine limiting points from the Kattegat region, mostly by dated marine shells and molluscs from coastal deposits and suggest RSL levels over 25 m b.s.l. (Fig. 9). In the slowly uplifting Halland region in Sweden the RSL rose from 15 b.s.l. to 14 m a.s.l. during this period (Fig. 8).

Lake-level data points of the AL include SLIPs derived from the isolated lake basins at different elevations and from rooted tree stumps. Isolation events have been detected by using diatom stratigraphy, threshold measurement and radiocarbon dating supported by counting of clay varves from site-specific sequences. Large lake diatoms like *Ellerbeckia arenaria* and *Aulacoseira islandica* have been typically used to distinguish the AL stage from an isolated lake stage (Grudzinska, 2015). AL data comprise also a large number of terrestrial limiting points including peat deposits and archaeological sites especially from the southern and eastern Baltic. Lake limiting points include mostly sedimentary indicators from AL deposits in the southern Baltic.

In the Bothnian region only negative lake level tendencies are available indicating that postglacial land uplift was faster than the effect of the up-damming of the AL. In the Ångermanland region in Sweden, the highest isolation basin was found at an elevation of 268 m a.s.l. and was dated to 10.6–10.2 ka BP (Fig. 7). Regions with moderate to slow uplift in Blekinge and Håväng (both Sweden) as in Tallinn and Pärnu (both Estonia) show positive lake-level tendencies from 11.0 to ~10.2 ka BP and negative lake-level tendencies from 10.2 to ~9.8 ka BP (Fig. 8). The magnitude of up-damming varies from 20 to 10 m depending on the intensity of the uplift and the availability of lake-level data points. Submerged rooted tree stumps from Blekinge and Håväng at different elevations suggest a rapid rise of the AL level reaching about 20 m with a rate of ~40 mm per year (Hansson et al., 2018). The oldest Mesolithic archaeological RSL indicators from the Håväng and Pärnu regions are also related to the AL transgression.

#### 4.4. RSL data and tendencies during the 9.8–8.5 ka BP (ILS stage)

This group includes sea-level data points from the Kattegat, Samsø Belt and Vendsyssel Thy (all Denmark), as from Göteborg to Halland in Sweden (SLIPs  $n = 5$ ; limiting points  $n = 13$ ) and ILS data from the eight regions of the BSB (SLIPs  $n = 30$ ; limiting points  $n = 97$ ).

Sea-level data points are represented by marine limiting points from the Kattegat region, mostly by dated marine shells and molluscs from coastal deposits. They suggest RSL levels above 23 to 22 m b.s.l. (Fig. 8). ILS data include SLIPs derived from isolated lake basins at different elevations. Isolation events have been detected by using diatom stratigraphy, threshold measurement and radiocarbon dating. During this stage, the distribution of brackish water diatoms like *Mastogloia smithii* is common to separate the ILS stage from an isolated lake stage (Grudzinska, 2015).

RSL data points from the ILS show negative tendencies in the northern BSB (Fig. 7) and positive tendencies in the southern BSB (Fig. 9). SLIPs from the Ångermanland and Gästrikland regions in Sweden show a fast drop in RSL at that time. About 9.5–9.1 ka BP, the RSL at the Lomtjärn site in Ångermanland was about 180 m a.s.l. (Fig. 7). In the Usedom/Rügen region in Germany, in the southern BSB, the RSL was 16 m b.s.l. around 8.9 ka BP (Fig. 9). SLIPs and terrestrial limiting points from Håväng and Pärnu show rather stable and low RSLs around 5 m b.s.l. to 1 m a.s.l. during the ILS. Despite the first evidences of marine water inflows in the southern BSB during the ILS (Andrén et al., 2011), stable and low RSL levels in Håväng and Pärnu suggest that RSL changes in the BSB were not fully controlled by sea-level rise in the world's oceans (Lambeck et al., 2014). Thus, the Early Holocene rapid sea-level rise, well

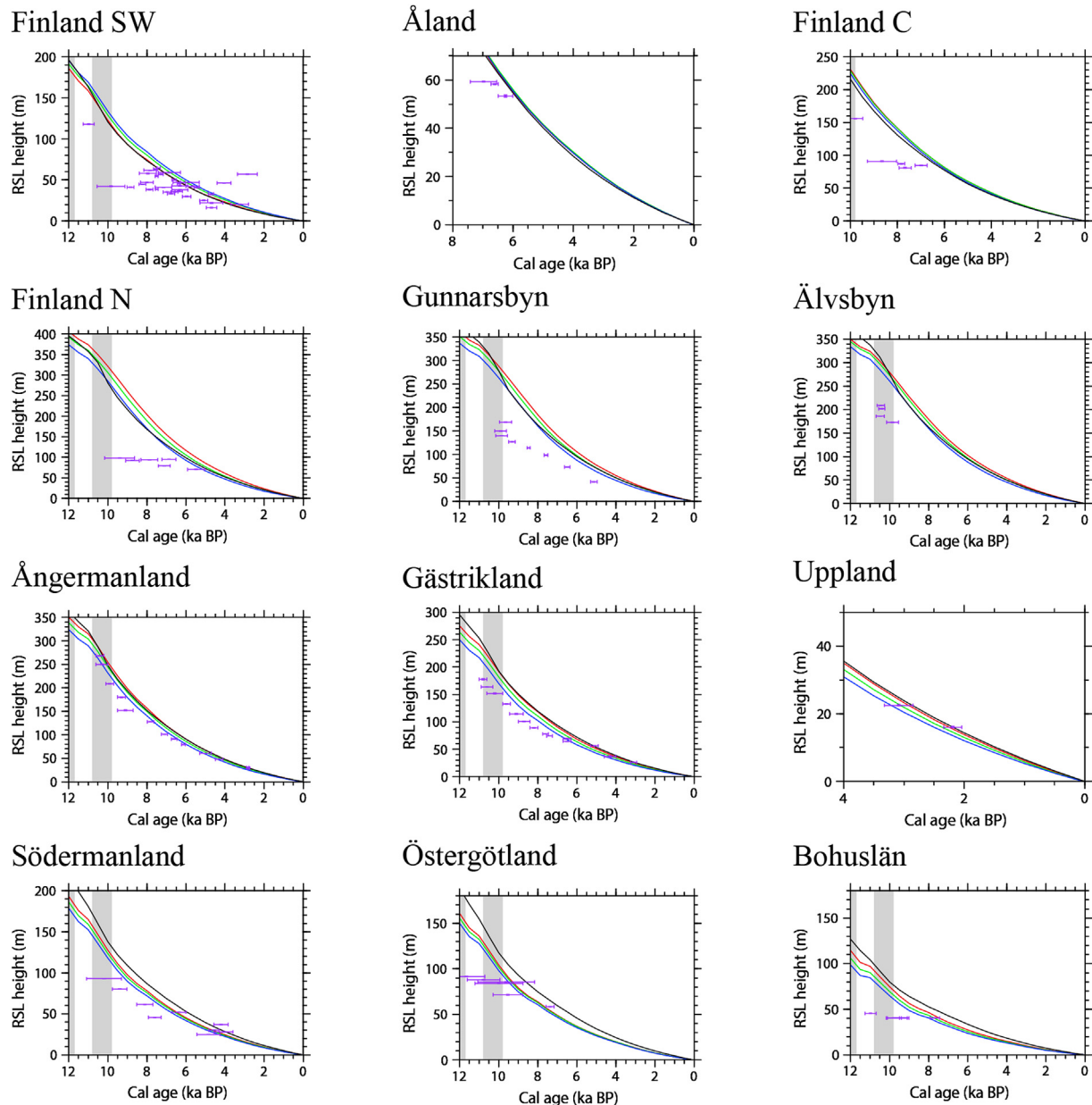

**Fig. 7.** Age elevation plots of RSL data points (accepted SLIPs (violet), terrestrial (green) and marine (blue) limiting points) showing a negative tendency and of predictions considering ICE-5G with three different lithosphere thicknesses, 80 km (red), 100 km (green) and 120 km (blue), and ICE-6G\_C(VM5a) (black). (For interpretation of the references to colour in this figure legend, the reader is referred to the Web version of this article.)

documented in the Rhine-Meuse delta, North Sea (Hijma and Cohen, 2019), is detectable in the BSB only since 8.5 ka BP.

#### 4.5. RSL data and tendencies since 8.5 ka BP (LS stage)

RSL data points from the BSB and Kattegat since 8.5 ka BP include 274 SLIPs and 468 limiting data points and are further grouped into three clusters according to their dominant RSL tendencies: regions with negative, positive and complex (transitional) RSL tendencies. Overall, regions with isostatic uplift-driven negative tendencies dominate and show regression and decreasing volume of the BSB during this last marine stage (Fig. 6).

##### 4.5.1. Regions with negative RSL tendencies

This cluster of RSL data points comprises 12 original regions

from the northern BSB including the Ångermanland region with evidence of the highest postglacial uplift in northern Europe. Thus, between 9.1 and 7.8 ka BP RSL dropped in Ångermanland from 152 to 128 m a.s.l. (Fig. 7).

SLIPs in this cluster contain data collected from isolated lake basins at different elevations, which were studied using diatom stratigraphy, threshold measurements and radiocarbon dating supported by counting of clay varves from site-specific sequences. Thresholds have been identified in the field and their elevations were determined typically by using benchmarks, but also by applying airborne LiDAR (Light detection and ranging) elevation data (Supplement 1). Accelerator mass spectrometry (AMS) and conventional radiocarbon dating of terrestrial plant material supported by age-depth modelling is the most typical method to establish chronologies of an isolation event. Data points from raised



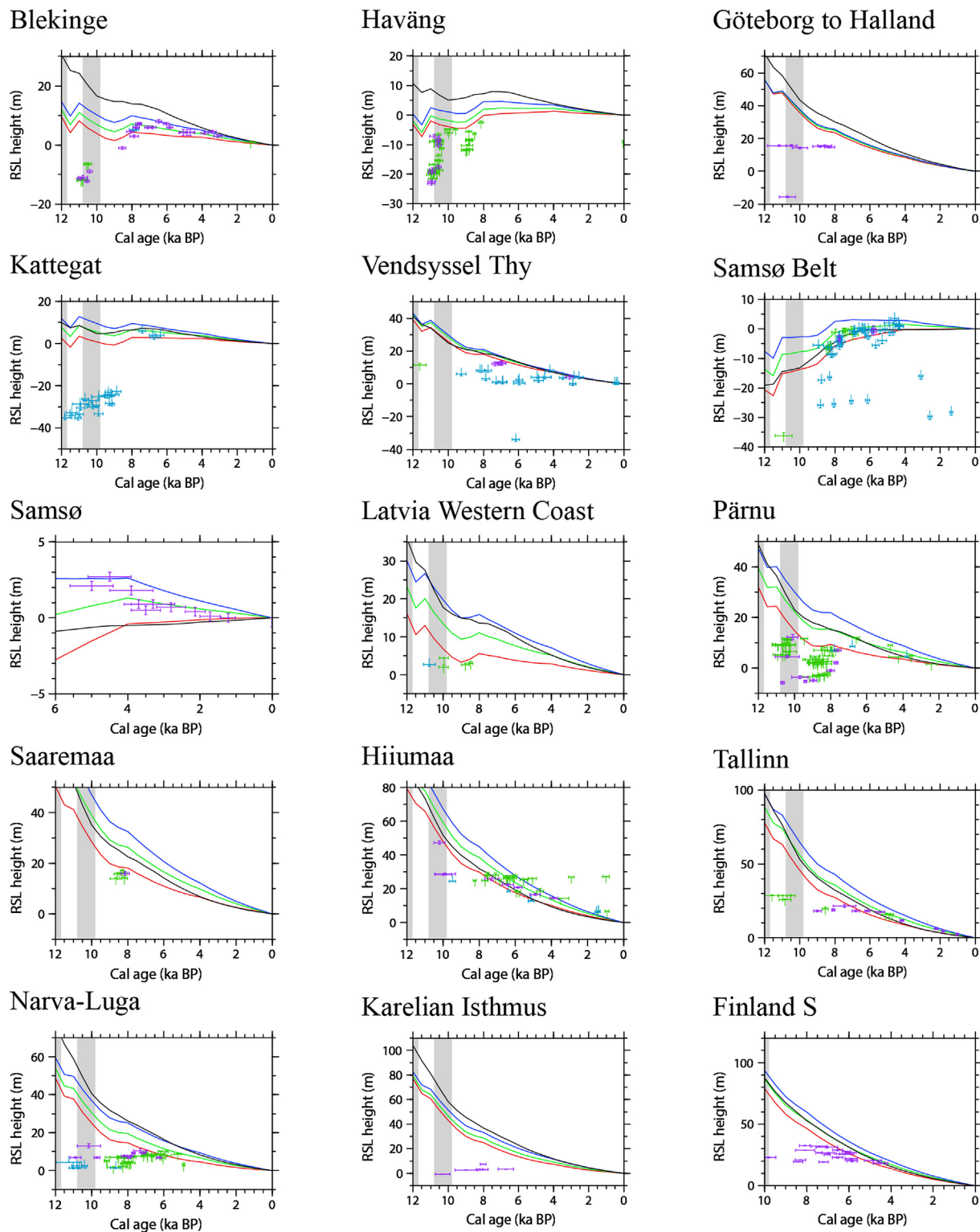

Fig. 8. RSL data showing the complex tendencies and predictions considering ICE-5G with three different lithosphere thicknesses and ICE-6G\_C(VM5a). For details see Fig. 7.

beaches are also available for this region, however, due to a poor age control some of these data points are rejected for further analyses. SLIPs from Ångermanland, Gästrikland, Södermanland (all Sweden) and Finland SW cover rather well the entire last marine stage while for most of the other regions the last 6000 years are quite poorly represented by RSL data points (Fig. 7).

#### 4.5.2. Transitional regions

This is the largest cluster of RSL data points and it includes 14 original regions from the BSB and Kattegat (Fig. 8). These RSL data comprise a large number of terrestrial limiting points including peat deposits and Mesolithic and Neolithic archaeological sites but include also SLIPs derived from intercalated peat layers, submerged

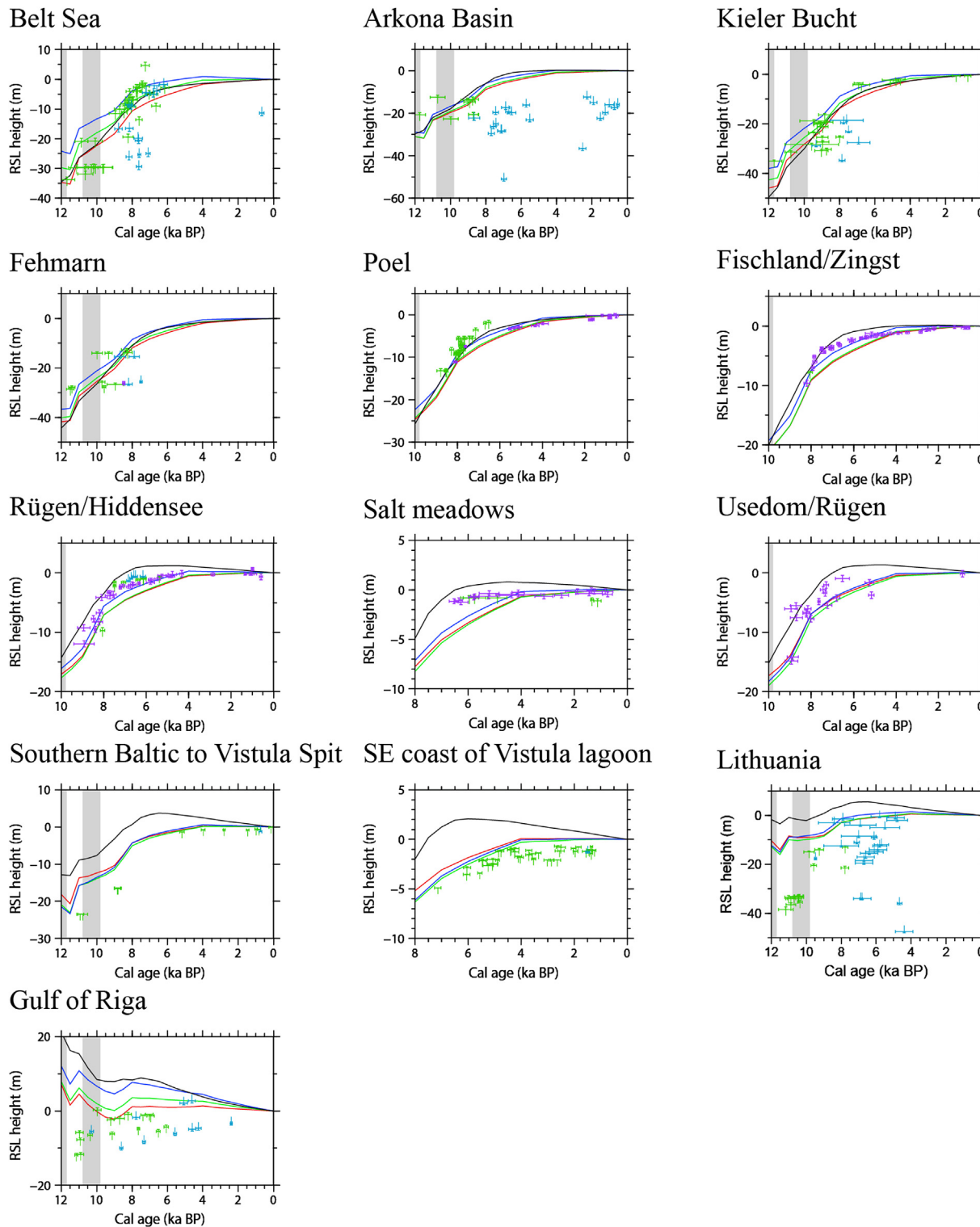

Fig. 9. RSL data showing the positive tendencies and predictions considering ICE-5G with three different lithosphere thicknesses and ICE-6G\_C(VM5a). For details, see Fig. 7.

rooted tree trunks, isolated lake basins using diatom stratigraphy and radiocarbon dating, or luminescence dated coastal landforms.

In general, the transitional regions in the BSB and the Kattegat show positive RSL tendencies from 8.5 to ~7 ka BP and negative RSL tendencies afterwards (Fig. 8). Shifts from positive to negative tendencies are dated in Finland S to ~7.3 ka BP (7.4–7.1 ka BP), in the Karelian Isthmus (Russia) to ~7.1 ka BP (7.3–6.8 ka BP), in Narva-

Luga (Estonia) to ~7.3 (7.7–6.9 ka BP) and in the Tallinn region to ~7.5 (8.1–6.8 ka BP) (Fig. 8; Supplement 1). RSL data points from the Pärnu and Blekinge regions combine SLIPs collected from onshore and offshore areas and show shifts from positive to negative tendencies at ~7.3 ka BP and at ~6.5 ka BP, respectively (Fig. 8). Thus, the age of the turning point from the positive to negative tendency in the transitional regions of the BSB vary between 7.5 and 7.1 (6.5)

ka BP, depending somewhat on the intensity of the uplift. This age is consistent with the end of the final melting of the Laurentide Ice Sheet and a remarkable slow-down in global sea-level rise (Lambeck et al., 2014).

#### 4.5.3. Regions with positive RSL tendencies

This cluster of RSL data points includes 13 original regions from the BSB (Fig. 9). In the Poel, Rügen/Hiddensee, Usedom/Rügen, Fishland/Zingst and Salt Meadows regions in Germany from salt meadows transgressed basal peat samples have been used mainly, which was supported by diatoms, pollen and plant macro remains, forming about 80% of all SLIPs in this cluster (Fig. 9). Terrestrial limiting points include *in situ* tree stumps and Mesolithic material covering the period ca 9–6 ka BP. AMS or conventional radiocarbon datings of terrestrial macrofossils from the peat layers have been used for the chronology. Data points from the Fehmarn Belt and Kieler Bucht regions in Germany include various terrestrial and marine limiting data points derived from offshore sediment cores drilled during the 1970s and 1980s. Their chronology covers the whole last marine stage and is based on conventional radiocarbon dating of lake, marine and peat deposits. Newer ages from the Fehmarn Belt from the 2000s are also based on AMS dating. Data points of the Arkona Basin are from the 1990s and include only marine limiting points (Fig. 9). Data points from the Vistula Lagoon in Poland include mostly terrestrial limiting points containing submerged peat layers supported by pollen analyses and *in situ* tree stumps. Their chronology covers the last 7000 years and is based on AMS radiocarbon dated terrestrial macrofossils, wood and bulk peat samples dated during the 21st century. Sample elevation uncertainties of this off- and onshore region is around  $\pm 0.1$  m.

Data points from the Gulf of Riga in Latvia comprise terrestrial and marine limiting points including peat and gyttja deposits supported by diatom analyses. Their chronology covers the period from 9 to 2 ka BP and is based on AMS radiocarbon dated terrestrial macrofossils and gyttja samples as well as conventional radiocarbon dates of peat, wood and gyttja samples. Sample elevations of the onshore samples were determined using topographic maps with uncertainties of  $\pm 0.5$  m.

Data points from the Belt Sea in Denmark include various terrestrial and marine limiting data points derived from offshore sediment cores suggesting RSL below 20 m b.s.l. around 8.5–8.0 ka BP (Fig. 9). However, SLIPs from Rügen/Hiddensee and Usedom/Rügen show up to 5 m higher RSL levels for the same period. SLIPs and terrestrial limiting points from Poel, Rügen/Hiddensee, Usedom/Rügen, and Fishland/Zingst also indicate the slowdown in Holocene RSL rise between 8 and 7 ka BP (Fig. 9).

#### 4.6. Vertical uncertainties in RSL data

Various methods were used to reconstruct SLIPs and limiting points in the BSB, which can cause different chronological and vertical uncertainties in the dataset. The main uncertainties are discussed in this chapter and specific details are provided in the country reports in Supplement 2. Converting original data to HOLSEA format provided a good template to systematically analyse the uncertainties, which has been done in most cases by original data producers and has been further discussed during the set up of the database. The RSL data from nine original data sets was presented.

A large number of SLIPs from the regions with negative and complex RSL tendencies comes from isolated lake basins. The detailed threshold identification, coring and elevation measurement is a standard procedure in sea-level studies. Still, for several sites original elevations have been taken from topographic maps. For these sites, the threshold elevations have been corrected by the

data providers during the database compilation by using newly available LiDAR elevation data, which provide the possibility to diminish the vertical accuracy to  $\pm 0.1$ – $0.2$  m (Supplement 2). For underwater sites, the vertical accuracy is estimated to be  $\pm 0.5$  m.

In offshore sea-level studies in regions with negative sea-level tendencies, the elevations are estimated based on the measured water depth and the shore-level height with vertical accuracy around  $\pm 1$  m. Sampling uncertainty depends on used coring equipment and methodology. In isolated basin studies, typically Russian corers have been used with uncertainties around  $\pm 0.05$  m while in vibra-coring and offshore gravity coring the uncertainties are higher being around  $\pm 0.15$  m.

Sediment compaction for basal peat samples is not significant, but for intercalated peat and gyttja samples, individual compaction factors have been considered. These errors have been evaluated site-by-site also using compaction models. The highest compaction values are related to the offshore and coastal samples from the southern BSB with values up to 5.9 m (Hoffmann et al., 2009).

We note that the height or depth of the data refers to a certain height system in place in the respective country. Most national height systems, for example RH2000 in Sweden, are national realisations of the European Vertical Reference System (EVRS) which in the countries surrounding the Baltic Sea refer to either NAP or the Kronstadt tide gauge. The latter is the zero level for the Baltic Height System (BHS77) in Russia and previously in many countries in Eastern Europe, and this zero level differs up to 0.2 m from the NAP. Hence, we applied a correction for such data points.

If known, the national height system is indicated in the database and, if needed, a correction is applied to transfer the height of an old height system to the current EVRS-related one. Such a correction is generally smaller than a few decimetres. If the height system is unknown, the year of sample discovery is listed and an uncertainty of 0.5 m is added. This concerns 539 samples, mostly related to the older offshore and some onshore data of the southern Baltic and Kattegat, and amounts to 40% in the database. We suggest a conservative uncertainty of 0.5 m based on findings by Nordman et al. (2015), who reanalysed RSL data, mainly based on varves, from Ångermanland, Sweden, as well as corrections applied to some Swedish data after transformation of data from the former national height system RH70 to the current RH2000. Nordman et al. (2015) identified different height systems for different portions of the Ångermanland record, which is close to today's land uplift maximum. The reference levels of two of the systems differ by 68 cm and have reference epochs being 70 years apart. We note though that the RSL data discussed in Nordman et al. (2015) were found in different decades since the beginning of the last century, while our database mainly contains data since the 1950s and data far away from the uplift maximum. Hence, 68 cm is considered as likely too large to be set as uncertainty. Our corrections to some Swedish data points, also near the uplift maximum, are at a level of 0.2–0.3 m and concern two height system epochs being 30 years apart. We thus think that an uncertainty of 0.5 m includes any uncertainties due to an unknown height system. The user is of course free to either revise this uncertainty value or update the database with the correct height value in the national height system related to the EVRS.

Besides the observational uncertainties, various climatological and geological factors may affect the accuracy of the RSL data. However, these are very difficult to assess. In the tide-less BSB, wind may cause high sea levels at the narrow ends of bays and gulfs, like the Gulfs of Finland, Bothnia and Riga. As most cyclones travel over the BSB from the SW or W to E, storm surges are usually generated in the E or NE sections of the Baltic Sea (Hünicke et al., 2015) and may affect Holocene RSL.

Local crustal (block) movements along existing fault lines have



been detected in western Sweden (Risberg et al., 1996) and SE Sweden (Risberg et al., 2005) by investigating Holocene isolated lake basins. We have not identified any local crustal instabilities in the RSL data nor did we apply any correction for such. Kierulf et al. (2021) recently analysed the vertical velocity field derived from GNSS around the Baltic Sea and could show local motions that cannot be explained by GIA or other known processes. Hence, the user should be aware that such local instabilities may sporadically be present and further corrections may be necessary.

#### 4.7. Age and chronological uncertainties in RSL data

About 97% of the SLIPs and limiting dates are radiocarbon dated (AMS or conventional dating) and have been calibrated using the OxCal program (Version 4.3). Terrestrial samples were calibrated using the IntCal13 calibration curve and marine samples using the Marine 13 calibration curve (Reimer et al., 2013) and reported with 2σ confidence interval. Most of the radiocarbon ages were corrected for isotopic fractionation. About 75% of the radiocarbon

dates originate from terrestrial samples such as seeds and fruits or wood samples from sediments or freshwater peat. Such material is usually considered reliable material for chronological studies. About 30% of the radiocarbon measurements are AMS ages. Bulk sediment samples such as gyttja or marine mud have also been widely used for radiocarbon dating. Bulk samples may contain a mixture of carbon of different ages and are therefore less reliable. Age-depth modelling was also used to date the SLIPs in the sediment sequences with multiple radiocarbon dates. Thus, the modelled age represents SLIP age and the actual radiocarbon dates represent terrestrial and or marine limiting points.

In the Ångermanland region, radiocarbon dating of the SLIPs is supported by counting of clay varves from site-specific sequences and, for three regions (Samsø, Lithuania, Hiiumaa) luminescence dating has also been used for chronology. Luminescence dating provides the possibility to date coastal deposits without carbon content, but suffers from larger chronological uncertainty than present in radiocarbon dating.

We advise the user interested in GIA modelling that the data

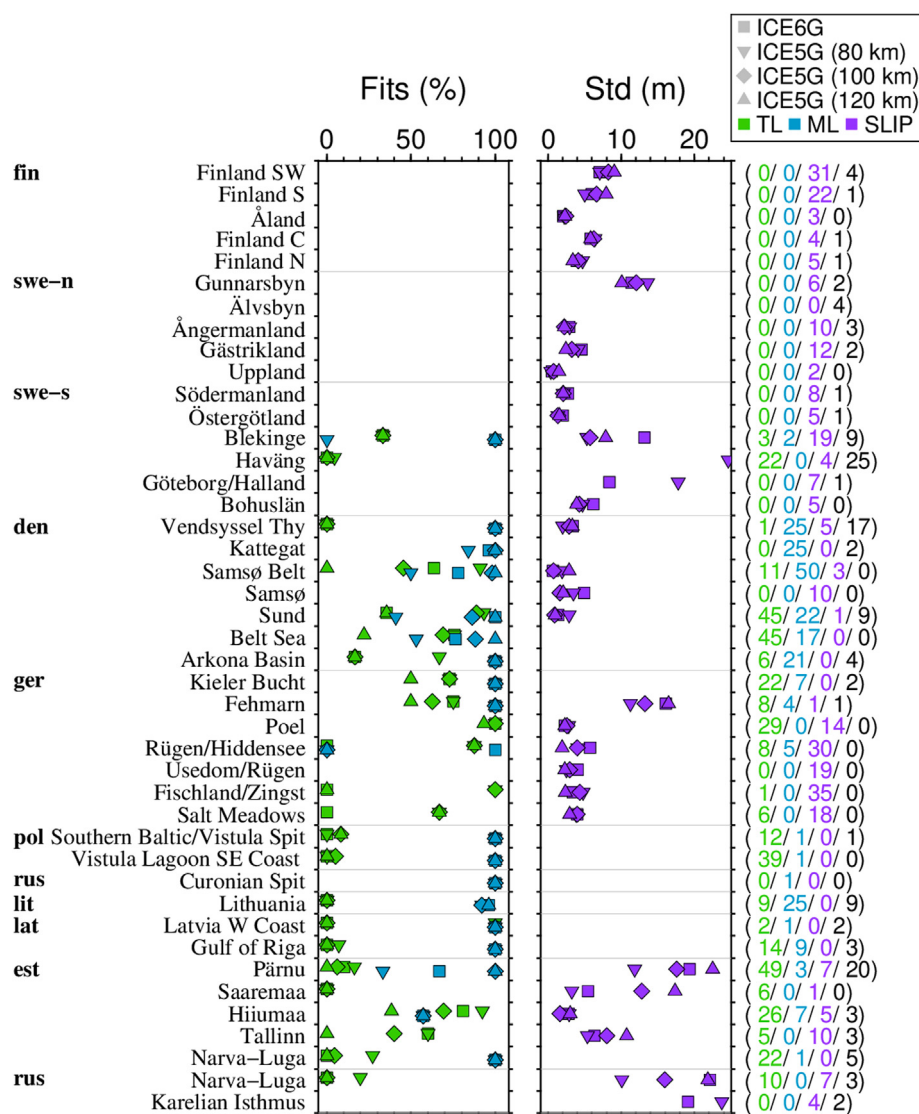

Fig. 10. Fit of four sea-level reconstructions for each considered study area. For terrestrial limiting points (TL) and marine limiting points (ML) the percentage in agreement with the reconstructions is given, for SLIPs the standard deviation (std) is given. RSL data considered here are only those not rejected or not associated with a Baltic Lake phase. On the right, the counts should read (# TL/# ML/# SLIP/# not considered). For the meaning of colours and symbols see the legend at the right top. For study areas showing no fits, all RSL data points have been neglected. (For interpretation of the references to colour in this figure legend, the reader is referred to the Web version of this article.)

need further treatment before being applicable in the modelling. Radiocarbon dating refers to 'present', i.e., the year 1950, while the height/depth of the sample refers to the epoch of the vertical reference frame of a certain system, e.g. European Vertical Reference Frame 2007 (EVRF2007) of the EVRS. This epoch is usually not 1950, and thus a height correction to 1950 has to be performed depending on specified vertical land motion, e.g. with land uplift models such as NKG2016LU (Vestøl et al., 2019) or other national transformations in place. The uncertainty for such corrections is usually negligible if the height system is known, while we suggest setting 10% of the height correction as uncertainty if the height system is unknown. The latter is based on tests we made with Swedish data near today's land uplift maximum. The difference of a geodetically correct transformation from one height system to another compared to one with simply using a land uplift model was 1–2 cm for total height corrections of 20–30 cm.

#### 4.8. RSL data and GIA model predictions

RSL data points from the last marine stage (since 8.5 ka BP) were compared with the publicly available GIA predictions including the global ICE-5G ice history (Peltier, 2004; with a lithospheric thickness of the Earth model: 80, 100, 120 km) and the ICE-6G\_C ice history together with its corresponding Earth model VM5a (Argus et al., 2014; Peltier et al., 2015).

Comparisons of RSL data sets with GIA predictions show relatively good fit with RSL data from the regions with negative tendencies including the regions with highest uplift in Ångermanland, Gästrikland and Uppland (Fig. 7 and 10). This was expected because

some of these data were used as major constraints in ice model developments and used in the generation of both ICE-5G and ICE-6G\_C models. Comparison of SLIPs from these regions shows that standard deviations values remain typically below 10 m, with the exception of the Gunnarsbyn data which shows systematically a lower RSL compared to the model predictions and a standard deviation of 10–14 m (Fig. 10).

Regions with positive RSL tendencies also show relatively good fit with GIA predictions with exception of the Fehmarn dataset which contains only one SLIP (Fig. 9 and 10). Standard deviation values are also around 5 m, however for the ICE-6G\_C model the differences are somewhat higher compared to other predictions (Fig. 10). Terrestrial limiting points from Vistula, Lithuania and the Gulf of Riga also show several meters lower levels compared to model predictions during the mid-Holocene.

The RSL data from the transitional regions shows a rather poor fit with GIA predictions, especially in the eastern BSB (Fig. 8). The mid-Holocene RSL highstand was reached in transitional regions of the BSB around 7.5–7.1 (6.5) ka BP indicating a slow-down of sea-level rise while ICE-5G and ICE-6G\_C models predict this highstand ca 500–700 years earlier (Fig. 8). For the Karelian Isthmus, Narva-Luga and Pärnu regions, ICE-5G and ICE-6G\_C model predictions fail to predict a marine transgression at 8.5–7 ka BP that is clearly documented in RSL records. For these three areas, standard deviation values are also highest for the ICE-6G\_C model being at about 20–25 m and for ICE-5G at about 10–24 m (Fig. 10). In the Finland S, Tallinn and Blekinge regions the differences are somewhat smaller, being at about 5–10 m. For the transgression period at about 8.5–7 ka BP, proxy reconstructions suggest clearly a lower RSL, which is further confirmed by terrestrial limiting points from Haväng (Figs. 8 and 10).

Geographically the highstand area is crossing the Jylland and Blekinge areas in the western BSB and Latvia, Estonia, and SE Finland. Compared to ICE-6G\_C model predictions the highstand area fits well with the RSL records in the western BSB but locating it ca 200–300 km northward in the eastern BSB (Fig. 11). Differences in RSL elevations and location of the highstand zones between model predictions and proxy reconstructions in the eastern BSB may suggest that the contribution of ice loading is overestimated in the ICE-5G and especially in the ICE-6G\_C models as the eastern BSB region has been previously rather poorly covered with the RSL data.

## 5. Conclusion

We provide a standardized and publicly available Holocene RSL database for the Baltic Sea and the Kattegat Sea with 867 sea-level data points. The database also includes 232 data points from the Ancyclus Lake phase (10.8–9.8 ka BP) and the following transitional phase (9.8–8.5 ka BP) in the Baltic Sea history, distinguished from the marine data. About 80% of RSL data is related to the last marine stage in the Baltic Sea history since 8.5 ka BP. This part contains 274 SLIPs and 468 marine and terrestrial limiting points which are grouped according to their dominant RSL tendencies into three clusters: regions with negative, positive and complex (transitional) RSL tendencies. Overall, regions with negative tendencies, associated with intense and still ongoing postglacial uplift, dominate and show falling RSL in the BSB. Shifts from positive to negative tendencies around 7.5–6.5 ka BP in transitional regions are consistent with the end of the final melting of the Laurentide Ice Sheet. Comparisons of RSL data with GIA predictions including global ICE-5G and ICE-6G\_C ice histories show good fit with RSL data from regions with negative tendencies, whereas in the transitional areas in the eastern BSB the predictions overestimate the RSL and fail to predict a mid-Holocene RSL highstand derived from the proxy

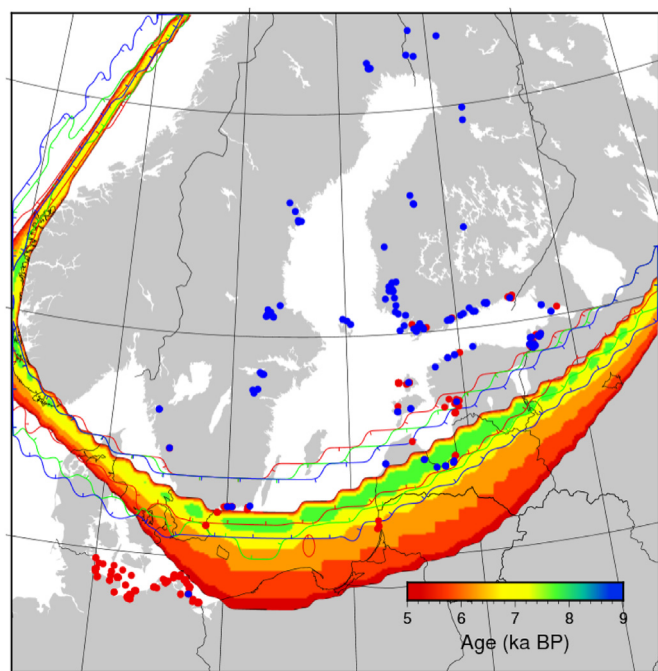

**Fig. 11.** Distribution of the mid-Holocene RSL highstand area for the considered GIA models together with RSL data points. The area is determined as the region where the tendency changes between 10 and 5 ka BP. The colours indicate the age of the highstand determined from ICE-6G\_C(VM5a). Inside the ring, the model predicts a continuous RSL fall, and outside a continuous rise. RSL data points with a negative tendency are shown as blue dots and points with a positive tendency are shown in red. Note that the mid-Holocene highstand timing is shifted from mid- to early Holocene due to interference with the uplift history. It is detected in the zone where negative and positive RSL tendencies co-occur and shows, the GIA model fails to predict the highstand zone in the eastern BSB. (For interpretation of the references to colour in this figure legend, the reader is referred to the Web version of this article.)

reconstructions. Differences in RSL elevations and the locations of the highstand zones between model predictions and proxy reconstructions in the eastern BSB may suggest that the contribution of ice loading is overestimated in the ICE-5G and especially in the ICE-6G\_C models. This example thus shows, among others, the potential of the database to serve in and revise ice history reconstructions.

Finally, we note that there is also a large number of late-glacial RSL data available related to the Baltic Ice Lake stage in the BSB history, which are useful in GIA modelling extending the time span beyond the Holocene (Lambeck et al., 1998, 2010). As more adequate and precise observations of isolations become available for the Baltic Ice Lake, the extension of the open-access Baltic database towards the late-glacial period would be a well-justified task for the future.

### Declaration of competing interest

The authors declare that they have no known competing financial interests or personal relationships that could have appeared to influence the work reported in this paper.

### Acknowledgements

We thank Kurt Lambeck and an anonymous reviewer for their critical reviews to improve the paper. We also thank Svante Björck for helpful discussion on RSL data. Jukka-Pekka Palmu, Annika Åberg and Susanne Åberg are acknowledged for compiling the Ancient Shoreline Database at the Geological Survey of Finland. Tina Kempe is thanked for help with data transformation to the current Swedish national height system RH2000. The research of Alar Rosentau was supported by Estonian Research Council grant PUT 456. The contribution of Volker Klemann, Milena Latinović and Meike Bagge was supported by German Federal Ministry of Education and Research (BMBF) as Research for Sustainability initiative (FONA); [www.fona.de](http://www.fona.de) through Palmod projects (FKZ: 01LP1503A, 01LP1502E, 01LP1918A). The GPR-based studies in the Danish area received funding from the Danish Research Council for Independent Research through a grant to Lars Nielsen. Sediment samples were dated with the luminescence method at the Nordic Laboratory for Luminescence Dating. The contribution of Yuriy Kublitskiy and Dmitry Subetto was funded by Russian Foundation for Basic Research (18-05-80087) and was supported by the Ministry of Education of the Russian Federation (FSZN-2020-0016). The research of Ieva Grudzinska was supported by Estonian Science Foundation grant 9031, Estonian Research Council grant IUT 1-8 and the Doctoral Studies and Internationalisation Programme DoRa. Most of the figures were created by the Generic Mapping Tools GMT4 (Wessel and Smith, 1998) and GMT6 (Wessel et al., 2019). This paper is a contribution to IGCP project 639 'Sea Level Change from Minutes to Millennia', supported by UNESCO and IUGS.

### Appendix A. Supplementary material 1

Excel file containing SLIPs and limiting points included in the Holocene relative sea-level database of the Baltic Sea. The database is provided at the GFZ data services (<https://doi.org/10.5880/GFZ.1.3.2020.003>).

### Appendix B. Supplementary material 2

Document file with country-wise description of the Holocene relative sea-level data. The document is provided at the GFZ data services (<https://doi.org/10.5880/GFZ.1.3.2020.003>).

### Appendix C. References to original publications of the RSL data

A large number of papers are only referenced in the database. In order to tribute the work of these primary authors, we decided to add also those references to the main document, following the discussion in Düsterhus et al. (2016):

**Finland:** Alhonen et al. (1978); Donner and Eronen (1981); Eronen (1974); Eronen et al. (2001, 1993, 1995, 1982); Glückert (1976, 1978a,b), Glückert et al. (1992, 1993); Haila et al. (1991); Hyvärinen (1979, 1982, 1984); Jungner and Sonninen (1983); Leino (1973); Miettinen (2002); Miettinen et al. (1999); Ristaniemi (1987); Ristaniemi and Glückert (1988); Saarnisto (1981); Salomaa (1982); Seppä et al. (2000); Tolonen and Tolonen (1988).

**Sweden N:** Lindén et al. (2006)

**Central Sweden:** Berglund (2004, 2005, 2008, 2010, 2012); Wallin (1994).

**Sweden S:** Hedenström and Risberg (2003); Mörner (1969); Persson (1979); Persson (1973); Robertsson (1991).

**Sweden SE:** Berglund (1964, 1971); Hansson (2018); Hansson et al. (2018a, 2019, 2018b); Liljegen (1970); Nylander (1969); Yu et al. (2007); Yu et al. (2003, 2005).

**Denmark:** Aaris-Sørensen and Petersen (1984); Andersen (2013); Bendixen et al. (2017); Bennike et al. (2012); Bennike and Jensen (1995, 1998, 2011, 2013); Bennike et al. (2000, 2004); Bennike and Lemke (2001); Bennike et al. (2017); Christensen (1982), 2014; Christensen et al. (1997); Christensen and Nielsen (2008); Christiansen et al. (1993); Fischer (1993), 2005; Hansen (1977); Hede et al. (2015); Hede (2003); Jensen and Bennike (2009); Jensen et al. (1997, 2002); Jensen and Stecher (1992); Knudsen (1978); Krog (1979); Krog and Tauber (1974); Nielsen et al. (2004); Petersen (1976), 1978, 1986, 1991, 1993; Petersen and Rasmussen (1995); Rahbek and Rasmussen (1994); Rasmussen (1992, 1995); Richardt (1996); Sander et al. (2015); Skaarup and Grøn (2004); Tauber (1966).

**Germany S-H:** Ernst (1974); Feldens and Schwarzer (2012); Harders et al. (2005); Heinrich et al. (2017); Winn et al. (1986).

**Germany M-V:** Hoffmann et al. (2009); Lampe et al. (2011); Lampe and Janke (2004); Naumann and Lampe (2014).

**Poland:** Miotk-Szpiganowicz (2016); Miotk-Szpiganowicz and Uścińowicz, (2013); Miotk-Szpiganowicz et al. (2009); Uścińowicz et al. (2013), 2011.

**Lithuania:** Bitinas et al. (2001, 2000, 2002, 2017, 2003); Damusyte' (2011); Gelumbauskaite' (2009); Girinninkas and Zulkus (2017); Trimonis et al. (2007); Žulkus and Girinninkas (2012)

**Latvia:** Bērziņš et al. (2016); Eberhards (2006, 2008); Grudzinska (2011, 2015); Grudzinska et al. (2017); Murniece et al. (1999); Pujate (2015); Punning et al. (1973); Veinbergs (1996).

**Estonia:** Grudzinska et al. (2013), 2014; Habicht et al. (2017); Haila and Raukas (1992); Heinsalu (2000); Hyvärinen et al. (1992); Jaanits and Jaanits (1978); Jaanits and Liiva (1973); Jonuks (2013, 2016); Kessel (1975); Kessel and Punning (1969a,b, 1974); Königsson et al. (1998); Kriiska (1995, 1996, 1999, 2001, 2002); Kriiska et al. (2005); Kriiska and Lõugas (1999, 2009); Kriiska et al. (2002); Lepland et al. (1996); Liiva et al. (1966); Lõugas and Tomek (2013); Ilves et al. (1974); Muru et al. (2017); Nirgi et al. (2020); Orru (1992); Poska and Veski (1999); Punning et al. (1971, 1977); Raukas et al. (1995, 1999); Reintam et al. (2008); Rosentau et al. (2013, 2020, 2011); Saarse et al. (2009, 2003, 2006); Sarv (1981); Vassiljev et al. (2015); Veski (1998); Veski et al. (2005).

**Russia:** Kessel (1963); Miettinen et al. (2007b); Morozov (2014); Rosentau et al. (2013); Saarse et al. (2003); Sandgren et al. (2004); Sergeev et al. (2015).



## Author contribution

Alar Rosentau, Ole Bennike, Antti Ojala, Mikael Berglund, Gustaf Peterson Becher, Kristian Schoning, Anton Hansson, Lars Nielsen, Lars B. Clemmensen, Mikkel U. Hede, Aart Kroon, Morten Pejrup, Lasse Sander, Karl Stattegger, Klaus Schwarzer, Reinhard Lampe, Matthias Lampe, Szymon Uścińowicz, Albertas Bitinas, Ieva Grudzinška, Jüri Vassiljev, Triine Nirgi, Yuriy Kublitskiy, and Dmitry Subetto provided RSL data, drafted country-wise data descriptions and reference lists (Appendix A–C). Volker Klemann compiled the initial RSL database that has been further developed by Alar Rosentau, Ole Bennike, and Holger Steffen. Volker Klemann and Alar Rosentau prepared figures and tables with support from Ole Bennike and Holger Steffen. Jasmin Wehr developed the parsing software for transferring excel sheets from and to the database system. Milena Latinović provided calibration workflows for the radiocarbon dates inside the database system. Meike Bagge and Holger Steffen provided GIA-modelling results. (see also Appendix B). Alar Rosentau, Volker Klemann, Ole Bennike, and Holger Steffen wrote the initial manuscript that has been revised and approved by all authors.

## Appendix D. Supplementary data

Supplementary data to this article can be found online at <https://doi.org/10.1016/j.quascirev.2021.107071>.

## References

- Aaris-Sørensen, K., Petersen, K.S., 1984. A Late Weichselian find of polar bear (*Ursus maritimus* Phipps) from Denmark and reflections on the palaeoenvironment. *Boreas* 13, 29–33.
- Alhonen, P., Eronen, M., Nunez, M., Salomaa, R., Uusinoka, R., 1978. A contribution to holocene shore displacement and environmental development in Vantaa, South Finland: the stratigraphy of Lake Lammaslampi. *Bull. Com. Geol. Finl.* 50 (1–2), 69–79.
- Andersen, S.H., 2013. Submerged mesolithic settlements in Denmark. *Jutland arch. Soc. Publ.* 77, 1–527.
- Andrén, T., Björck, S., Andrén, E., Conley, D., Zillén, L., Anjar, J., 2011. The development of the Baltic Sea basin during the last 130 ka. In: Harff, J., Björck, S., Hoth, P. (Eds.), *The Baltic Sea Basin*. Springer, Heidelberg Dordrecht Berlin New York, pp. 75–97.
- Andrén, E., Andrén, T., Sohlenius, G., 2000. The Holocene history of the south-western Baltic Sea as reflected in a sediment core from the Bornholm basin. *Boreas* 29, 233–250.
- Andrén, T., Lindeberg, G., Andrén, E., 2002. Evidence of the final drainage of the Baltic Ice Lake and the brackish phase of the Yoldia Sea in glacial varves from the Baltic Sea. *Boreas* 31, 226–238.
- Argus, D.F., Peltier, W.R., Drummond, R., Moore, A.W., 2014. The Antarctica component of postglacial rebound model ICE-6G\_C (VM5a) based upon GPS positioning, exposure age dating of ice thicknesses, and relative sea level histories. *Geophys. J. Int.* 198, 537–563. <https://doi.org/10.1093/gji/ggu140>.
- Astrup, P.M., 2019. In: *Sea-Level Change in Mesolithic Southern Scandinavia: long- and short-term effects on society and the Environment*. Jutland Archaeology Society Series 106. Aarhus University Press, pp. 1–207.
- Baranskaya, A.V., Khan, N.S., Romanenko, F.A., Roy, K., Peltier, W.R., Horton, B.P., 2018. A postglacial relative sea-level database for the Russian Arctic coast. *Quat. Sci. Rev.* 199, 188–205.
- Batchelor, C.L., Margold, M., Krapp, M., Murton, D.K., Dalton, A.S., Gibbard, P.L., Stokes, C.R., Murton, J.B., Manica, A., 2019. The configuration of Northern Hemisphere ice sheets through the Quaternary. *Nat. Commun.* 10 (1), 1–10.
- Bendixen, C., Jensen, J.B., Boldreel, L.O., Clausen, O.R., Bennike, O., Seidenkrantz, M.-S., Nyberg, J., Hübscher, C., 2017. The Holocene Great Belt connection to the southern Kattegat, Scandinavia: Ancyclus Lake drainage and early Littorina Sea transgression. *Boreas* 46, 53–68.
- Bennike, O., Andreasen, M.S., Jensen, J.B., Noe-Nyegaard, N., 2012. Early Holocene sea-level changes in Øresund, Scandinavia. *Bull. Geol. Surv. Denm. Greenl.* 26, 29–32.
- Bennike, O., Jensen, J.B., 1995. Near shore Baltic Ice Lake deposits in Fakse Bugt, southeast Denmark. *Boreas* 24, 185–195.
- Bennike, O., Jensen, J.B., 1998. Late- and postglacial shore level changes in the southwestern Baltic Sea. *Bull. Geol. Surv. Denm.* 45, 27–38.
- Bennike, O., Jensen, J.B., 2011. Postglacial relative shore level changes in Lillebelt, Denmark. *Bull. Geol. Surv. Denm. Greenl.* 23, 37–40.
- Bennike, O., Jensen, J.B., 2013. A Baltic Ice Lake lowstand of latest Allerød age in the Arkona Basin, southern Baltic Sea. *Bull. Geol. Surv. Denm. Greenl.* 28, 17–20. <https://doi.org/10.34194/geusb.v28.4710>.
- Bennike, O., Jensen, J.B., Konradi, P., Lemke, W., Heinemeier, J., 2000. Early Holocene lagoonal deposits from Kattegat, Scandinavia. *Boreas* 29, 272–286.
- Bennike, O., Jensen, J.B., Lemke, W., Kuijpers, A., Lomholt, S., 2004. Late- and postglacial history of the Great Belt, Denmark. *Boreas* 33, 18–33.
- Bennike, O., Lemke, W., 2001. Late-glacial and early postglacial finds of *Ancyclus fluviatilis* from the south-western Baltic Sea. *Geol. Fören. Stockholm Föhr.* 123, 81–84.
- Bennike, O., Pantmann, P., Aarsleff, E., 2017. Holocene development of the Arresø area, north-east Sjælland. *Bull. Geol. Surv. Denm.* 65, 25–35.
- Berglund, B., 1964. The post-glacial shore displacement in eastern Blekinge, southeastern Sweden. *Sverig. Geol. Unders.* C599, 47.
- Berglund, B., 1971. Littorina transgressions in Blekinge, South Sweden – a preliminary survey. *Geol. Fören. Stockholm Föhr.* 93, 625–652.
- Berglund, B.E., Sandgren, P., Barnekow, L., Hannon, G., Jiang, H., Skog, G., Yu, S.-Y., 2005. Early Holocene history of the Baltic Sea, as reflected in coastal sediments in Blekinge, southeastern Sweden. *Quat. Int.* 130 (1), 111–139.
- Berglund, M., 2004. Holocene shore displacement and chronology in Angermanland, eastern Sweden, the Scandinavian glacio-isostatic uplift centre. *Boreas* 33, 48–60. <https://doi.org/10.1111/j.1502-3885.2004.tb00995.x>.
- Berglund, M., 2005. The Holocene shore displacement of Gästrikland, eastern Sweden: a contribution to the knowledge of Scandinavian glacio-isostatic uplift. *J. Quat. Sci.* 20, 519–531.
- Berglund, M., 2008. Time-transgressive early Holocene vegetational succession following shore displacement: a case study from central Sweden. *Boreas* 37, 87–101.
- Berglund, M., 2010. Littorina Sea shore displacement and pollen analytical indications of forest succession during the Mid-Holocene in Gästrikland, east central Sweden. *Geol. Fören. Stockholm Föhr.* 132, 213–226.
- Berglund, M., 2012. Early Holocene in Gästrikland, east central Sweden: shore displacement and pattern of isostatic recovery. *Boreas* 41, 263–276.
- Berzins, V., Lübke, H., Berga, L., Cerina, A., L, K., Meadows, J., et al., 2016. Recurrent mesolithic–neolithic occupation at site (western Latvia) and shoreline displacement in the Baltic Sea basin. *Holocene* 26, 1319–1325. <https://doi.org/10.1177/0959683616638434>.
- Bitinas, A., Damusyte, A., Hütt, G., Jaek, I., Kabaliene, M., 2001. Application of the OSL dating to stratigraphic correlation of late Weichselian and Holocene sediments in the Lithuanian maritime region. *Quat. Sci. Rev.* 21, 767–772.
- Bitinas, A., Damusyte, A., Hütt, G., Martma, T., Ruplėnaite, G., Stancikaite, M., et al., 2000. Stratigraphic correlation of Late Weichselian and Holocene deposits in the Lithuanian coastal region. *Proc. Est. Acad. Sci. Geol.* 49 (3), 200–217.
- Bitinas, A., Damusyte, A., Stancikaite, M., Aleksa, P., 2002. Geological development of the Nemunas River delta and adjacent areas, west Lithuania. *Geol. Quat.* 46 (4), 375–389.
- Bitinas, A., Mazeika, J., Buynėvich, I.V., Damusyte, A., Molodkov, A., Grigienė, A., 2017. Constraints of radiocarbon dating in southeastern Baltic lagoons: assessing the vital effects. In: Harff, J., Furmančzyk, K., von Storch, H. (Eds.), *Coastline Changes of the Baltic Sea from South to East – Past and Future Projection*, vol. 19. Coastal Research Library, Cham: Springer, pp. 137–171.
- Bitinas, A., Zulkus, V., Mazeika, J., Petrosius, R., Kisieliene, D., 2003. Medziu liekanos Baltijos juros dugne: pirmieji tyrimu rezultatai (In Lithuanian). *Geologija* 43, 43–46.
- Björck, S., 1995. A review of the history of the Baltic Sea, 13.0–8.0 ka BP. *Quat. Int.* 27, 19–40.
- Björck, S., BACC Author Team, 2008. *The late Quaternary development of the Baltic Sea basin. In: Assessment of Climate Change for the Baltic Sea Basin*. Springer-Verlag Berlin Heidelberg, pp. 398–407.
- Christensen, C., 1982. Havniveausendringer 5500–2500 f. Kr. i Vedbekområdet, Nordøstsjælland. *Dansk Geol. Fören. Arsskrift* for 91–107, 1981.
- Christensen, C., 2014. Havniveausendringer 5500–2500 f. Kr. I Vedbek-Omradet, NØ-Sjælland – Fortsatte Geobotaniske Undersøgelser I Arene 1982–1990. *Nationalmuseets Naturvidenskabelige Undersøgelser NNU-Rapport* 2014.
- Christensen, C., Fischer, A., Mathiasen, D.R., 1997. The great sea rise in the Storebælt. In: Pedersen, L., Fischer, A., Aaby, B. (Eds.), *The Danish Storebælt since the Ice Age. A/S Storebæltforbindelsen*, Copenhagen, pp. 45–54, 323–324.
- Christensen, C., Nielsen, A.B., 2008. Dating Littorina Sea shore levels in Denmark on the basis of data from a Mesolithic coastal settlement on Skagens Odde, northern Jutland. *Pol. Geol. Inst. Spec. Pap.* 23, 27–38.
- Christiansen, C., Conradsen, K., Emelyanov, E., Trimonis, E., Heinemeier, J., Rud, N., 1993. Hydrographic changes in the southern Kattegat (Scandinavia) during the early Holocene transgression. *Boreas* 22, 349–356.
- Damusyte, A., 2011. *Post-glacial Geological History of the Lithuanian Coastal Area, Summary of Doctoral Dissertation (Doctoral Dissertation, Physical Sciences, Geology (05P) (Vilnius))*.
- Donner, J., Eronen, M., 1981. Stages of the Baltic Sea and late Quaternary shoreline displacement in Finland: excursion guide. In: University of Helsinki. Department of Geology, Division of Geology and Palaeontology. Stencil. University of Helsinki, Helsinki.
- Douglas, B.C., Peltier, W.R., 2002. The puzzle of global sea-level rise. *Phys. Today* 55, 35–40.
- Düsterhus, A., Rovere, A., Carlson, A.E., Horton, B.P., Klemann, V., Tarasov, L., et al., 2016. Palaeo-sea-level and palaeo-ice-sheet databases: problems, strategies, and perspectives. *Clim. Past* 12 (4), 911–921. <https://doi.org/10.5194/cp-12-911-2016>.
- Eberhards, G., 2006. Relief, geological structure and development of Purciems area

- (in Latvian). In: Loze, I. (Ed.), *Neolithic Dune Settlements in Northern Kurzeme*. Institute of the History of Latvia Publishers, Riga, Latvia, pp. 12–28.
- Eberhards, G., 2008. Overview of Geological and Palaeoenvironmental Research at Area of Stone Age Settlement Priedaine. Riga, Latvia.
- Ekman, M., 1996. A consistent map of the postglacial uplift of Fennoscandia. *Terra Nova* 8, 158–165.
- Ekman, M., 2009. The Changing Sea Level of the Baltic Sea during 300 Years: A Clue to Understanding the Earth. Summer Institute for Historical Geophysics, Åland Islands (Sweden), pp. 1–155.
- Ernst, T., 1974. Die Hohwachter Bucht. Morphologische Entwicklung einer Küstenlandschaft Ostholsteins. *Schr. Naturw. Verein Schl.-Holst.* 44, 47–96.
- Eronen, M., 1974. The history of the Litorina Sea and associated Holocene events (Supplement: pollen and diatom diagrams). *Soc. Scient. Fenn., Comm. Phys. Math.* 44, 79–195.
- Eronen, M., Glückert, G., Hatakka, L., Plassche, O., van de Plicht, J., Rantala, P., 2001. Rates of Holocene isostatic uplift and relative sea-level lowering of the Baltic in SW Finland based on studies of isolation contacts. *Boreas* 30, 17–30.
- Eronen, M., Glückert, G., van de Plassche, O., van der Plicht, J., Rajala, P., Rantala, P., 1993. The postglacial radiocarbon-dated shoreline data in Finland for the nordic data base of land uplift and shorelines (No. Project NKS/KAN 3, subproject 3.2.4.2, 1992–93, stencil). Swedish Nuclear Power Inspectorate (SKI) 1–40.
- Eronen, M., Glückert, G., van de Plassche, O., van der Plicht, J., Rantala, P., 1995. Land uplift in the Olkiluoto-Pyhäjärvi area, southwestern Finland, during the last 8000 years. In: Tiivistelmä: Maankohoaminen Viimeisen 8000 Vuoden Aikana Olkiluodon-Pyhäjärven Alueella Lounais-Suomessa. Voimayhtiöiden Ydinjätetoimikunta. Voimayhtiöiden ydinjätetoimikunta, Helsinki. Report YJT-95-17.
- Eronen, M., Heikkinen, O., Tikkanen, M., 1982. Holocene development and present hydrology of Lake Pyhäjärvi in Satakunta, southwestern Finland. *Fennia* 160, 195–223.
- Feldens, P., Schwarzer, K., 2012. The Ancylus Lake stage of the Baltic Sea in Fehmarn Belt: indications of a new threshold? *Continental Shelf Res.* 35, 43–52.
- Fischer, A., 1993. Stenalderbopladser på bunden af Øresund. Del 1. Det centrale Øresund. Skov- og Naturstyrelsen.
- Fischer, A., 2005. Mennesket og havet i eldre stenalder. In: Bunte, C. (Ed.), *Arkeologien Och Naturvetenskap*. Gyllenstiernska Krapperupstiftelsen, Lund, pp. 227–297.
- Garcia-Artola, A., Stephan, P., Cearreta, A., Kopp, R.E., Khan, N.S., Horton, B.P., 2018. Holocene sea-level database from the Atlantic coast of Europe. *Quat. Sci. Rev.* 196, 177–192.
- Gelumbauskaite, L., 2009. Character of sea level changes in the subsiding south-eastern Baltic Sea during Late Quaternary. *Baltica* 22 (1), 77–82.
- Girinninkas, A., Zulkus, V., 2017. Baltijos jūros krantai ir žmonės ankstyvajame holocene. (In Lithuanian). In: 10-oji Nacionalinė Jūros Mokslo Ir Technologijų Konferencija „Jūros Ir Krantu Tyrimai 2017“, 2017 Balandžio 26–28, Palangos Kurhauzo Salev. Klaipėdos universiteto leidykla, pp. 69–72.
- Glückert, G., 1976. Post-glacial shore-level displacement of the Baltic in SW Finland. *Ann. Acad. Sci. Fenn., Ser. A III* 118, 32–33.
- Glückert, G., 1978a. Das Deltakomplex von Kiikalannummi am 3. Salpausselkä in Südwestfinland. Abstract: the Kiikalannummi delta, 3rd Salpausselkä, SW Finland. Turun yliopiston maaperägeologian osaston julkaisuja. Turun yliopisto, Turku, pp. 1–26.
- Glückert, G., 1978b. Östersjöns Postglaciala Strandförskjutning Och Skogens Historia På Åland. Turun Yliopiston Maaperägeologian Osaston Julkaisuja, pp. 1–106.
- Glückert, G., Illmer, K., Kankainen, T., Rantala, P., Räsänen, M., 1992. Littoistenjärven ympäristön kasvillisuuden kehitys jääkauden jälkeen ja järven luonnollinen happamoituminen. Turun yliopiston maaperägeologian osaston julkaisuja. Turku: Turun yliopisto 1–27.
- Glückert, G., Rantala, P., Ristaniemi, O., 1993. Itämeren jääkauden jälkeinen rannansiirtyminen Pohjanmaalla. Abstract: postglacial shore-level displacement of the Baltic in Ostrobothnia. In: Turun Yliopiston Maaperägeologian Osaston Julkaisuja. Turku: Turun Yliopisto, vol. 77, pp. 5–36.
- Groß, D., Zander, A., Boethius, A., Dreibrodt, S., Grøn, O., Hansson, A., Jesseng, C., Koivisto, S., Larsson, L., Lübke, H., Nilsson, B., 2018. People, lakes and seashores: studies from the Baltic Sea basin and adjacent areas in the early and Mid-Holocene. *Quat. Sci. Rev.* 185, 27–40.
- Grudzinska, I., 2011. Reflection of Palaeoenvironmental Conditions in Lake Sediments of Different Genesis (Master's Thesis in Latvian). University of Latvia, Faculty of Geography and Earth Sciences, Department of Environmental Sciences, Riga, Latvia.
- Grudzinska, I., 2015. Diatom stratigraphy and relative sea level changes of the eastern Baltic Sea over the Holocene. In: Doctoral Thesis on Natural and Exact Sciences. Tallinn University of Technology, Tallinn, Estonia, p. 80.
- Grudzinska, I., Saarse, L., Vassiljev, J., Heinsalu, A., 2013. Mid- and Late-Holocene shoreline changes along the southern coast of the Gulf of Finland. *Bull. Geol. Soc. Finland* 85, 19–34.
- Grudzinska, I., Saarse, L., Vassiljev, J., Heinsalu, A., 2014. Biostratigraphy, shoreline changes and origin of the Limnea Sea lagoons in northern Estonia: the case study of Lake Harku. *Baltica* 27 (1), 15–24.
- Grudzinska, I., Vassiljev, J., Saarse, L., Reitalu, T., Veski, S., 2017. Past environmental change and seawater intrusion into coastal Lake Lilaste, Latvia. *J. Paleolimnol.* 57, 257–271.
- Habicht, H.-L., Rosentau, A., Joeleht, A., 2017. IS-based multiproxy coastline reconstruction of the eastern gulf of Riga, Baltic Sea, during the stone age. *Boreas* 46, 83–99.
- Haila, H., Raukas, A., 1992. Ancylus Lake. In: Raukas, A., Hyvärinen, H. (Eds.), *Geology of the Gulf of Finland*. Estonian Academy of Sciences, Tallinn, pp. 283–296.
- Haila, H., Sarmaja-Korjonen, K., Uutela, A., 1991. Development of a Litorina Bay at Epoo, near Porvoo, southern Finland. *Bull. Geol. Soc. Finland* 63 (2), 105–119.
- Hansen, J.M., 1977. Sedimentary history of the island Læsø, Denmark. *Bull. Geol. Surv. Denm.* 26, 217–236.
- Hansson, A., 2018. Submerged landscapes in the Hanö Bay. Early Holocene shoreline displacement and human environments in the southern Baltic Basin. *Lundqua Thesis* 85, 146.
- Hansson, A., Nilsson, B., Sjöström, A., Björck, S., Holmgren, S., Linderson, H., Magnell, O., Rundgren, M., Hammarlund, D., 2018. A submerged Mesolithic lagoonal landscape in the Baltic Sea southeastern Sweden – early Holocene environmental reconstruction and shore-level displacement based on a multiproxy approach. *Quat. Int.* 463, 110–123.
- Hansson, A., Björck, S., Heger, K., Holmgren, S., Linderson, H., Magnell, O., et al., 2018a. Shoreline displacement and human resource utilization in the southern Baltic Basin coastal zone during the early Holocene: new insights from a submerged Mesolithic landscape in south-eastern Sweden. *Holocene* 28, 721–737.
- Hansson, A., Boethius, A., Hammarlund, D., Lageras, P., Magnell, O., Nilsson, B., Nilsson Brunlid, A., Rundgren, M., 2019. Shoreline displacement, coastal environments and human subsistence in the Hanö Bay region during the mesolithic. *Quaternary* 2, 14.
- Hansson, A., Nilsson, B., Sjöström, A., Björck, S., Holmgren, S., Linderson, H., et al., 2018b. A submerged Mesolithic lagoonal landscape in the Baltic Sea, south-eastern Sweden – early Holocene environmental reconstruction and shore-level displacement based on a multiproxy approach. *Quat. Int.* 463, 110–123.
- Harders, R., Dehde, B., Diesing, M., Gelhart, M., Schwarzer, K., 2005. Post-glacial development of Neustadt Bay in the western Baltic Sea. *Meyniana* 57, 37–60.
- Hede, M.U., Sander, L., Clemmensen, L.B., Kroon, A., Pejrup, M., Nielsen, L., 2015. Changes in Holocene relative sea-level and coastal morphology: a study of a raised beach ridge system on Samsø, southwest Scandinavia. *Holocene* 25, 1402–1414.
- Hede, S.U., 2003. Prehistoric settlements and Holocene relative sea-level changes in north-west Sjælland, Denmark. *Bull. Geol. Surv. Denm.* 50, 141–149.
- Hedenström, A., Risberg, J., 2003. Shore displacement in northern Uppland during the last 6500 calendar years. SKB Technical Report No. 03-17. Swedish Nuclear Fuel and Waste Management Co, p. 49.
- Heinrich, C., Anders, S., Schwarzer, K., 2017. Indications of late Pleistocene and early Holocene environmental changes affecting the water levels in the eastern Fehmarn Belt and Mecklenburg bight, SW Baltic Sea. *Boreas* 47, 754–776.
- Heinsalu, A., 2000. Diatom stratigraphy and palaeoenvironment of the Yoldia Sea in northern Estonia. *Proc. Est. Acad. Sci. Geol.* 49, 218–243.
- Hijma, M., Cohen, K., 2019. Holocene sea-level database for the Rhine-Meuse Delta, The Netherlands: implications for the pre-8.2 ka sea-level jump. *Quat. Sci. Rev.* 214, 68–86.
- Hijma, M., Engelhart, S., Horton, B.P., Törnqvist, T., Hu, P., Hill, D., 2015. A protocol for a geological sea-level database. In: Shennan, I., Long, A.J., Horton, B.P. (Eds.), *Handbook of Sea-Level Research*. Wiley Blackwell, pp. 536–553. <https://doi.org/10.1002/9781118452547.ch34>.
- Hoffmann, G., Schmedemann, N., Schafmeister, M.-T., 2009. Relative sea-level curve for SE Rügen and Usedom Island (SW Baltic Sea coast, Germany) using decompressed profiles. *Z. Dtsch. Ges. Geowiss.* 160 (1), 69–78.
- Houmark-Nielsen, M., Kjær, K.H., 2003. Southwest Scandinavia, 40–15 ka BP: palaeogeography and environmental change. *J. Quat. Sci.* 18, 769–786.
- Hünicke, B., Zorita, E., Soomere, T., Madsen, K.S., Johansson, M., Suursaar, Ü., 2015. Recent change – sea level and wind waves. Second assessment of climate change for the Baltic Sea Basin. *Regional Climate Studies*. Springer, pp. 155–185.
- Hyvärinen, H., 1979. Helsingin seudun rannansiirtyminen Litorina-aikana Sipoosta tutkitun näytesarjan valossa. Summary: bakunkärsträsket: a stratigraphical site relevant to the Litorina shore displacement near Helsinki. *Terra* 91 (1), 15–20.
- Hyvärinen, H., 1982. Interpretation of stratigraphical evidence of sea-level history: a Litorina site near Helsinki, southern Finland. *Ann. Acad. Sci. Fenn., Ser. A III* 134, 139–149.
- Hyvärinen, H., 1984. The Mastogloia stage in the Baltic Sea history: diatom evidence from southern Finland. *Bull. Geol. Soc. Finland* 56 (1–2), 99–115.
- Hyvärinen, H., Raukas, A., Kessel, H., 1992. Mastogloia and Litorina seas. In: Raukas, A., Hyvärinen, H. (Eds.), *Geology of the Gulf of Finland*. Estonian Academy of Sciences, Tallinn, pp. 296–311.
- Iives, E., Liiva, A., Punning, J.-M., 1974. Radiocarbon Method and its Application in Estonian Quaternary Geology and Archaeology. Academy of Sciences of the ESSR, Tallinn.
- Jaanis, L., Jaanis, K., 1978. Ausgrabungen der frühmesolithischen Siedlung von Pulli. *Eesti Teaduste Akadeemia Toimetised* 27, 56–63.
- Jaanis, L., Liiva, A., 1973. Eesti vanima ajaloo kronoloogia ja radiosüsiniku meetod. In: Alumäe, N. (Ed.), *Eesti NSV Teaduste Akadeemia 1965–1972*, pp. 157–161.
- Jensen, J.B., Bennike, O., 2009. Geological setting as background for methane distribution in Holocene mud deposits, Arhus Bay, Denmark. *Continental Shelf Res.* 29, 775–784.
- Jensen, J.B., Bennike, O., Witkowski, A., Lemke, W., Kuijpers, A., 1997. The Baltic Ice Lake in the southwestern Baltic: sequence-, chrono- and biostratigraphy. *Boreas* 26, 217–236.
- Jensen, J.B., Bennike, O., Witkowski, A., Lemke, W., Kuijpers, A., 1999. Early Holocene history of the southwestern Baltic Sea: the Ancylus Lake stage. *Boreas* 28,

- 437–453.
- Jensen, J.B., Petersen, K.S., Konradi, P., Kuijpers, A., Bennike, O., Lemke, W., Endler, R., 2002. Neotectonics, Sea-level changes and biological evolution in the Fennoscandian border zone of the southern Kattegat Sea. *Boreas* 31, 133–150.
- Jensen, J.B., Stecher, O., 1992. Paraglacial barrier-lagoon development in the late Pleistocene Baltic Ice Lake, southwestern Baltic. *Mar. Geol.* 107, 81–101.
- Jonuks, T., 2013. An antler object from the Pärnu River – an axe, a god, or a decoy? In: Johanson, K., Tõrv, M. (Eds.), *Man, His Time, Artefacts, and Places: Collection of Articles Dedicated to Richard Indreko*. MT, Tallinn, pp. 225–246.
- Jonuks, T., 2016. A Mesolithic human figurine from River Pärnu, South-West Estonia: a century-old puzzle of idols, goddesses and ancestral symbols. *Est. J. Archaeol.* 20, 111–127.
- Jungner, H., Sonninen, E., 1983. Radiocarbon Dates II. University of Helsinki, Helsinki: University of Helsinki.
- Kakkuri, J., 1997. Postglacial deformation of the Fennoscandian crust. *Geophysica* 33, 99–109.
- Kessel, H., 1963. On the age of Holocene transgressions of the Baltic Sea in Estonia by palynological analysis. *Baltica* 1, 101–115.
- Kessel, H., 1975. Läänemere Geoloogiline Areng Hiisglatsiaalis Ja Holotseenis Eesti Territooriumil, Tallinn: ENSV TA Geoloogia Instituut (unpublished report in State Archives).
- Kessel, H., Punning, J.-M., 1969a. Sedimente des Joldiamerees in Estland. *Eesti Teaduste AkadToimetised* 18, 154–163.
- Kessel, H., Punning, J.-M., 1969b. Über das absolute Alter der Holozänen Transgressionen der Ostsee in Estland. *Eesti Teaduste AkadToimetised* 18, 141–153.
- Kessel, H., Punning, J., 1974. About the age of the Ancylus stage in Estonia. *Eesti Teaduste AkadToimetised*, Keemia, Geol. 23, 59–64.
- Khan, N.S., Horton, B.P., Engelhart, S., Rovere, A., Vacchi, M., Ashe, E.L., Törnqvist, T.E., Dutton, A., Hijma, M.P., Shennan, I., HOLSEA working group, 2019. Inception of a global atlas of sea levels since the Last Glacial Maximum. *Quat. Sci. Rev.* 220, 359–371.
- Kierulf, H.P., Steffen, H., Barletta, V.R., Lidberg, M., Johansson, J., Kristiansen, O., Tarasov, L., 2021. A GNSS velocity field for geophysical applications in Fennoscandia. *J. Geodyn.* 146, 101845. <https://doi.org/10.1016/j.jog.2021.101845>.
- Knudsen, K.L., 1978. Middle and late Weichselian marine deposits at Nørre Lyngby, northern Jutland, Denmark and their foraminiferal faunas. *Danm. Geol. Unders.* II 112, 44.
- Königsson, L., Saarse, L., Veski, S., 1998. Holocene history of vegetation and landscape on the Kõpu peninsula, Hiiumaa Island, Estonia. *Proc. Est. Acad. Sci. Geol.* 47, 3–19.
- Kriiska, A., 1995. New Neolithic settlements in Riigiküla. *Eesti Teaduste AkadToimetised* 44, 448–454.
- Kriiska, A., 1996. Stone Age settlements in the lower reaches of the Narva River, north-eastern Estonia. *PACT* 51, 359–369.
- Kriiska, A., 1999. Formation and development of the Stone Age settlement at Riigiküla, northeastern Estonia. *PACT* 57, 173–183.
- Kriiska, A., 2001. Archaeological field work on Stone Age settlement site of SW Estonia. In: *Archaeological field work in Estonia 2000*, Estonia, pp. 19–33.
- Kriiska, A., 2002. Läänemere saarte asustamine ja püsilanikkonna kujunemine. *Keskus-tagamaa-ääreala. Muinasaja Teadus* 11, 29–60.
- Kriiska, A., Lavento, M., Peets, J., 2005. New AMS Dates of the Neolithic and Bronze Age Ceramics in Estonia: Preliminary Results and Interpretations.
- Kriiska, A., Lougas, L., 1999. Late mesolithic and early Neolithic seasonal settlement at Kõpu, Hiiumaa island, Estonia. In: Miller, U., Hackens, T., Lang, V., Raukas, A., Hicks, S. (Eds.), *Environmental and Cultural History of the Eastern Baltic Region* (Pact 57), pp. 157–172 (Rixensart, Belgium).
- Kriiska, A., Lougas, L., 2009. Stone Age settlement sites on an environmentally sensitive coastal area along the lower reaches of the River Pärnu (southwestern Estonia), as indicators of changing settlement patterns, technologies and economies. In: McCarta, S., Schulting, R., Warren, G.e. a. (Eds.), *Mesolithic Horizons*. Oxbow Books, Oxford, pp. 167–175.
- Kriiska, A., Saluäär, U., Lougas, L., 2002. Archaeological excavations in Sindi-lodja. In: Tamla, Ü. (Ed.), *Archaeological Fieldwork in Estonia 2001*. Muinsuskaitseamet, Tallinn, pp. 27–40.
- Krog, H. (1979). Quaternary history of the Baltic, Denmark. In V. Gudelis & L.-K. Königsson (Eds.), *The Quaternary History of the Baltic* (pp. 207–217). Uppsala: Acta Univ. Ups., Symp. Univ. Ups. Annum Quingentesimum Celebrantis.
- Krog, H., Tauber, H., 1974. C-14 chronology of late- and post-glacial marine deposits in North Jutland. *Danm. Geol. Unders. Arbobg* for 93–105, 1973.
- Lambeck, K., Smither, C., Johnston, P., 1998. Sea-level change, glacial rebound and mantle viscosity for northern Europe. *Geophys. J. Int.* 134, 102–144. <https://doi.org/10.1046/j.1365-246x.1998.00541.x>.
- Lambeck, K., Rouby, H., Purcell, A., Sun, Y., Sambridge, M., 2014. sea Level and global ice volumes from the last glacial maximum to the Holocene. *Proc. Natl. Acad. Sci. Unit. States Am.* 111, 1529615303.
- Lambeck, K., Purcell, A., Zhao, J., Svensson, N.-O., 2010. The Scandinavian ice sheet: from MIS 4 to the end of the last glacial maximum. *Boreas* 39, 410–435.
- Lampe, R., Endtmann, E., Janke, W., Meyer, H., 2011. Relative sea-level development and isostasy along the NE German Baltic Sea coast during the past 9 ka. *E&G Quaternary Science Journal* 59 (1/2), 3–20.
- Lampe, R., Janke, W., 2004. The Holocene sea-level rise in the southern Baltic as reflected in coastal peat sequences. *Pol. Geol. Inst. Spec. Pap.* 11, 19–30.
- Leino, J., 1973. Eräiden Umpeenkasvusoiden Turvesuhteista Salon Ympäristössä. *Pro Gradu-Tutkielma Syksyllä 1973*. Maaperägeologian Laitos, Turun Yliopisto.
- Lemke, W., Jensen, J.B., Bennike, O., Witkowski, A., Kuijpers, A., 1999. No indication of a deeply incised Dana River between Arkona Basin and Mecklenburg bay. *Baltica* 12, 66–70.
- Lepland, A., Hang, T., Kihno, K., Sakson, M., Sandgren, P., 1996. Changes and environmental history in the Narva area. In: *Coastal Estonia. Recent Advances in Environmental and Cultural History*, vol. 51. PACT, Rixensart, pp. 205–216.
- Leppäranta, M., Myrberg, K., 2009. *Physical Oceanography of the Baltic Sea*. Springer, Berlin, p. 336.
- Liiva, A., Ilves, E., Punning, J., 1966. Verzeichnis der im Institut für Zoologie und Botanik der Akademie der Wissenschaften der Estnischen SSR mittels der Radiokohlenstoffmethode datierten Proben (in Russian with German summary). *Eesti Teaduste AkadToimetised*, Biol. Ser. 1, 112–122.
- Liljegren, R., 1970. Litorinasediment I Omradet Mellan Ronneby Och Karlshamn. MS.
- Lindén, M., Möller, P., Björck, S., Sandgren, P., 2006. Holocene shore displacement and deglaciation chronology in Norrbotten, Sweden. *Boreas* 35, 1–22. <https://doi.org/10.1080/03009480500359160>.
- Lougas, L., Tomek, T., 2013. Marginal effect at the coastal area of Tallinn Bay: the marine, terrestrial and avial fauna as a source of subsistence during the late Neolithic. *Muinasaja Teadus* 19, 463–485.
- Medvedev, I.P., Rabinovich, A.B., Kulikov, E.A., 2013. Tidal oscillations in the Baltic Sea. *Oceanology* 53, 526–538.
- Miettinen, A., 2002. Relative sea level changes in the eastern part of the Gulf of Finland during the last 8000 years. *Ann. Acad. Sci. Fenn.*, Ser. A III 162, 5–91.
- Miettinen, A., Eronen, M., Hyvärinen, H., 1999. Land uplift and relative sea-level changes in the Loviisa area, southeastern Finland, during the last 8000 years. In: *Tiivistelmä: Maankohoaminen Ja Merenpinnan Suhteellinen Korkeusvaihtelu Viimeisen 8000 Vuoden Aikana Loviisan Alueella Kaakkois-Suomessa*. Posiva-Report. Posivai Oy, Helsinki.
- Miettinen, A., Jansson, H., Alenius, T., Haggren, G., 2007a. Late Holocene sea-level changes along the southern coast of Finland. *Baltic Sea. Mar. Geol.* 242, 27–38.
- Miettinen, A., Savelieva, L., Subetto, D.A., Dzhinoridze, R., Arslanov, K., Hyvärinen, H., 2007b. Palaeoenvironment of the Karelian Isthmus, the easternmost part of the gulf of Finland, during the Litorina Sea stage of the Baltic Sea history. *Boreas* 36, 441–458.
- Miotk-Szpiganowicz, G., 2016. Stop 4 – coast of the Vistula lagoon (Przebrno). peatbogs and fossil soils of the Vistula Spit. In: *The 13th Colloquium on Baltic Sea Marine Geology – Abstract Volume & Field Trip Guidebook*. Polish Geological Institute – National Research Institute, Warsaw, pp. 125–129.
- Miotk-Szpiganowicz, G., Uścińowicz, S., 2013. Stanowisko 4. Rozwój torfowisk nadbrzeżnych Zalewu Wiślanego. In: *VI Polska Konferencja Paleobotaniki Czwartorzędu „Osady morskie. Iagunowe i torfowisk nadbrzeżnych jako źródło informacji o paleośrodowiskach i klimacie”*. PiG-PiB, Warszawa, pp. 106–121.
- Miotk-Szpiganowicz, G., Uścińowicz, S., Przedziecki, P., W. J., 2009. Reconstruction of the paleo-landscapes of the southern Baltic. w: M. Manders, R. Oosting. *Final Report*. In: Brouwers (Ed.), MACHU (Managing Cultural Heritage Underwater), vol. 33. Educom Publisher BV, Rotterdam, pp. 80–84.
- Mörner, N.-A., 1969. The late Quaternary history of the Kattegatt Sea and the Swedish west coast. *Sverig. Geol. Unders.* C 640, 1–487.
- Morozov, D., 2014. Paleogeological Reconstruction of Lake Systems, the Southern Edifice of Fennoscandia (Russian). Doctoral dissertation. Herzen State Pedagogical University of Russia, St. Petersburg).
- Murniece, S., Kalnina, L., Berzins, V., Grasis, N., 1999. Environmental change and prehistoric human activity in western Kurzeme, Latvia. In: Miller, U., Hackens, T., Lang, V., Raukas, A., Hicks, S. (Eds.), *Environmental and Cultural History of the Eastern Baltic Region*, Journal of the European Network of Scientific and Technical Cooperation for Cultural Heritage, vol. 57, pp. 35–69.
- Muru, M., Rosentau, A., Kriiska, A., Lougas, L., Kadakas, U., Vassiljev, J., et al., 2017. Sea level changes and Neolithic hunter-fisher-gatherers in the centre of Tallinn, southern coast of the Gulf of Finland, Baltic Sea. *Holocene* 27, 917–928. <https://doi.org/10.1177/0959683616678462>.
- Muschitiello, F., Lea, J.M., Greenwood, S.L., Nick, F.M., Brunner, L., MacLeod, A., Wohlfarth, B., 2016. Timing of the first drainage of the Baltic Ice Lake synchronous with the onset of Greenland Stadial 1. *Boreas* 45, 322–334.
- Naumann, M., Lampe, R., 2014. The evolution of a southern Baltic coastal barrier system, deduced from geostatistical based volume calculations and relative sea-level rise (Darss-Zingst-Hiddensee area/NE Germany). *Ber. Röm.-Germ. Komm* 92, 297–324, 2011.
- Nielsen, P.E., Jensen, J.B., Binderup, M., Lomholt, S., Kuijpers, A., 2004. Marine aggregates in the Danish sector of the Baltic Sea: geological setting, exploitation potential and environmental assessment. *Z. Ang. Geol. Sonderheft* 2, 87–109, 2004.
- Nirgi, T., Rosentau, A., Habicht, H.-L., Hang, T., Jonuks, T., Jõelet, A., Kihno, K., Kriiska, A., Mustasaar, M., Risberg, J., Suuroja, S., Talviste, P., Tõnisson, H., 2020. Holocene relative shore-level changes and Stone Age palaeogeography of the Pärnu Bay area, eastern Baltic Sea. *Holocene* 30, 37–52.
- Nordman, Maaria, Milne, Glen, Tarasov, Lev, et al., 2015. Reappraisal of the Angerman River decay time estimate and its application to determine uncertainty in Earth viscosity structure. *Geophys. J. Int.* 201, 811–822. <https://doi.org/10.1093/gji/ggv051>.
- Nylander, C.E., 1969. *Vegetationshistoria Och Vegetation I Södra Brakne-Hoby Socken*. MS.
- Obrochta, S.P., Andrén, T., Fazekas, S.Z., Loughheed, B.C., Snowball, I., Yokoyama, Y., Miyairi, Y., Kondo, R., Kotilainen, A.T., Hyttinen, O., Fehr, A., 2017. The undatables: quantifying uncertainty in a highly expanded Late Glacial-Holocene sediment sequence recovered from the deepest Baltic Sea basin—IODP Site



- M0063. G-cubed 18 (3), 858–871.
- Orru, M., 1992. Estonian Peat Resources. Eesti Geoloogiakeskus, Tallinn.
- Peltier, W.R., 2004. Global glacial isostasy and the surface of the ice-age earth: the ICE-5G (VM2) model and GRACE. *Annu. Rev. Earth Planet Sci.* 32, 111–149. <https://doi.org/10.1146/annurev.earth.32.082503.144359>.
- Peltier, W.R., Argus, D.F., Drummond, R., 2015. Space geodesy constrains ice age terminal deglaciation: the global ICE-6G\_C (vm5a) model. *J. Geophys. Res.* 120, 450–487. <https://doi.org/10.1002/2014JB011176>.
- Persson, C., 1979. Shore displacement during Ancylus time in the Rejmyra area, south Central Sweden. *Sverig. Geol. Unders.* C 755, 1–23.
- Persson, G., 1973. Postglacial transgressions in Bohuslän, southwestern Sweden. *Sverig. Geol. Unders.* C 684, 1–47.
- Petersen, K.S., 1976. Om Limfjordens postglaciale marine udvikling og niveauforhold, belyst ved mollusk-faunaen og c-14 dateringer. *Danm. Geol. Unders. Arbog* for 75–103, 1975.
- Petersen, K.S., 1978. Den postglaciale transgression og molluskfaunaen i Tude A-området. *Store Belt. Danm. Geol. Unders. Arbog* for 39–52, 1977.
- Petersen, K.S., 1986. The Ertebølle „køkkenmødding” and the marine development of the Limfjord, with particular reference to the molluscan fauna. *J. Dan. Archeol.* 5, 77–84.
- Petersen, K.S., 1991. Holocene coastal and faunal development of the Skagen Odde, northern Jutland, Denmark. *Quat. Int.* 9, 53–60.
- Petersen, K.S., 1993. Environmental changes recorded in the Holocene molluscan faunas from Djursland, Denmark. *Scripta Geol. Spec. Issues* 2, 359–369.
- Petersen, K.S., Rasmussen, K.L., 1995. The impact of radiocarbon datings on natural historical sciences in Denmark especially paleozoological and shoreline datings. *PACT* 49 (8), 117–130.
- Poska, A., Veski, S., 1999. Man and environment at 9500 BP. a palynological study of an Early-Mesolithic settlement site in South-West Estonia. In: *Proceedings of the Fifth EPPC (Acta Palaeobotanica)*, pp. 603–607. Retrieved from <http://www.%20diva-portal.org/smash/record.jsf?pid=diva2%3A63966&ds%20wid=7163>.
- Pujate, A., 2015. Traces of Environmental Change and Human Impact in the Sediments of Lakes along the Coast of the Gulf of Riga (In Latvian with English Summary). Doctoral dissertation, University of Latvia, Faculty of Geography and Earth Sciences, Department of Environmental Science, Riga).
- Punning, J.M., Kakum, T., Rajamäe, R., 1973. Tallinn radiocarbon dates I. *Radiocarbon* 15, 586–591.
- Punning, J.-M., Ilves, E., Liiva, A.e. a., 1971. Tartu radiocarbon dates V. *Radiocarbon* 13, 78–83.
- Punning, J.-M., Rajamäe, R., Ehrenpreis, M.e. a., 1977. Tallinn radiocarbon dates IV. *Radiocarbon* 19, 111–117.
- Rahbek, U., Rasmussen, K.L., 1994. Danske Arkæologiske 14C-Dateringer, København 1993. arkud, pp. 276–288, 1993.
- Rasmussen, K.L., 1992. Danske Arkæologiske 14C-Dateringer, København 1991. arkud, pp. 233–251, 1991.
- Rasmussen, P., 1995. Stavns fjordens alder. In: Hansen, H.H., Aaby, B. (Eds.), *Stavns Fjord – et natur- og kulturhistorisk forskningsområde på Samsø*. Carlsberg-fondet og Nationalmuseet, København, pp. 23–33.
- Raukas, A., Kimmel, K., Rajamäe, R., 1995. A new site of buried peat at Lõpe, SW Estonia. In: *Proceedings of the Estonian Academy of Sciences: Geology*, vol. 44, pp. 133–137.
- Raukas, A., Moora, T., Karukäpp, R., 1999. The development of the Baltic Sea and Stone Age settlement in the Pärnu area of southwestern Estonia. *PACT* 57, 15–34.
- Reimer, P.J., Bard, E., Bayliss, A, et al., 2013. IntCal 13 and Marine 13 radiocarbon age calibration curves 0–50 000 years cal BP. *Radiocarbon* 55, 1869–1887. [https://doi.org/10.2458/azu\\_js\\_rc.55.16947](https://doi.org/10.2458/azu_js_rc.55.16947).
- Reintam, R., Moora, T., Raukas, A., 2008. Gleysols on sandy deposits of the Litorina Sea underlain by Histosol formations of Ancylus Lake age in western Estonia. *Est. J. Earth Sci.* 57, 231–240.
- Richardt, N., 1996. Sedimentological examination of the Late Weichselian sea-level history following deglaciation of northern Denmark. In: Andrews, J.T., Austin, W.E.N., Bergsten, H., Jennings, A.E. (Eds.), *Late Quaternary Palaeoceanography of the North Atlantic Margins*, vol. 111. Geological Society Special Publication, pp. 261–273.
- Risberg, J., Sandgren, P., Andren, E., 1996. Early Holocene shore displacement and evidence of irregular isostatic uplift northwest of Lake Vänern, western Sweden. *J. Paleolimnol.* 15 (1), 47–63.
- Risberg, J., Alm, G., Goslar, T., 2005. Variable isostatic uplift patterns during the Holocene in southeast Sweden, based on high-resolution AMS radiocarbon datings of lake isolations. *Holocene* 15 (6), 847–857.
- Ristaniemi, O., 1987. Itämeren Korkein Ranta Ja Ancylusraja Sekä Muinais-Päijänne Keski-Suomessa. [the Highest Shore and Ancylus Limit of the Baltic Sea and the Ancient Lake Päijänne in Central Finland]. Publication of University of Turku. University of Turku, Turku.
- Ristaniemi, O., Glückert, G., 1988. Ancylusja litorinatransgressioit lounais-suomessa. In: Lappalainen, V., Papunen, H. (Eds.), *Tutkimuksia Geologian Alalta (Vol. Ser. C 67, Turun Yliopiston Julkaisuja)*. Turku: Turun Yliopisto, pp. 129–145.
- Robertsson, A.-M., 1991. Strandföskjutningen i Eskilstunatrakten för ca 9000 till 4000 år sedan. *Sverig. Geol. Unders. Rapp. med.* 67, 1–27.
- Rosentau, A., Bennike, O., Uścinowicz, S., Miotk-Szpiganowicz, G., 2017. The Baltic Sea basin. In: Flemming, N.C., Harff, J., Moura, D., Burgess, A., Bailey, G.N. (Eds.), *Submerged Landscapes of the European Continental Shelf: Quaternary Paleoenvironments*. Springer, Dordrecht, pp. 103–134.
- Rosentau, A., Harff, J., Oja, T., Meyer, M., 2012. Postglacial rebound and relative sea level changes in the Baltic Sea since the Litorina transgression. *Baltica* 25, 113–120.
- Rosentau, A., Muru, M., Kriiska, A., Subetto, D.A., Vassiljev, J., Hang, T., Gerasimov, D., Nordqvist, K., Ludikova, A., Lougas, L., Raig, H., Kihno, K., Aunap, R., Letyka, N., 2013. Stone age settlement and Holocene shore displacement in the Narva-Luga Klint Bay area, eastern Gulf of Finland. *Boreas* 42 (4), 912–931.
- Rosentau, A., Nirgi, T., Muru, M., Bjursäter, S., Hang, T., Preusser, F., et al., 2020. Holocene relative shore level changes and stone age hunter-gatherers in Hiiumaa island, eastern Baltic Sea. *Boreas* 49 (4), 783–798. <https://doi.org/10.1111/bo.12452>.
- Rosentau, A., Veski, S., Kriiska, A., et al., 2011. Palaeogeographic model for the SW Estonian coastal zone of the Baltic Sea. In: Harff, J., Björck, S., Hoth, P. (Eds.), *The Baltic Sea Basin (Central and Eastern European Development Studies)*. Springer, Berlin; Heidelberg, pp. 165–188.
- Saarnisto, M., 1981. Holocene emergence history and stratigraphy in the area north of the Gulf of Bothnia. *Ann. Acad. Sci. Fenn. Ser. A III* 130, 7–42.
- Saarse, L., Heinsalu, A., Veski, S., 2009. Litorina sea sediments of ancient Väana Lagoon, northwestern Estonia. *Est. J. Earth Sci.* 58 (1), 85–93.
- Saarse, L., Vassiljev, J., Miidel, A., 2003. Simulation of the Baltic Sea shorelines in Estonia and neighbouring areas. *J. Coast Res.* 19, 261–268.
- Saarse, L., Vassiljev, J., Miidel, A., Niinemets, E., 2006. Holocene buried organic sediments in Estonia. *Proc. Est. Acad. Sci. Geol.* (55), 296–320.
- Salomaa, R., 1982. Post-glacial shoreline displacement in the Lauhanvuori area, western Finland. In: *Studies on the Baltic Shorelines and Sediments Indicating Relative Sea-Level Changes : Proceedings of the Symposium of INQUA Sub-commission on Shorelines of Northwestern Europe*, vol. 134. Suomalainen tiedeakatemia, Helsinki, pp. 81–97. Lammi 13th September 1981, *Annales Academiae Scientiarum Fennicae. Series A. III. Geologica - Geographica*.
- Sander, L., Fruergaard, M., Koch, J., Johannessen, P.N., Pejrup, M., 2015. Sedimentary indications and absolute chronology of Holocene relative sea-level changes retrieved from coastal lagoon deposits on Samsø, Denmark. *Boreas* 44, 706–720.
- Sandgren, P., Subetto, D.A., Berglund, B.E., Davydova, N.N., Savelieva, L.A., 2004. Mid-Holocene Littorina Sea transgressions based on stratigraphic studies in coastal lakes of NW Russia. *Geol. Fören. Stockholm Förh.* 126, 363–380.
- Sarv, A., 1981. Geochronological subdivision of Holocene bog—lacustrine deposits in the region of Koivasoo swamp (Hiiumaa Island, Estonia) (in Russian). *Proc. Est. Acad. Sci. Geol.* 30, 173–178.
- Seppä, H., Tikkanen, M., Shemeikka, P., 2000. Late-Holocene shore displacement of the Finnish south coast : diatom, litho- and chemostratigraphic evidence from three isolation basins. *Boreas* 29 (3), 219–231.
- Sergeev, A., Sivkov, V., Zhamoida, V., Ryabchuk, D., Bitinas, A., Mazeika, J., 2015. Holocene organic-rich sediments within the Curonian Spit coast, the south-eastern Baltic Sea. *Baltica* 28, 41–50.
- Shennan, J., Bradley, S., Edwards, R., 2018. relative sea-level changes and crustal movements in Britain and Ireland since the last glacial maximum. *Quat. Sci. Rev.* 188, 143–159.
- Skaarup, J., Grøn, O., 2004. Geology and topography. In: Skaarup, J., Grøn, O. (Eds.), *Møllegabet II, a Submerged Mesolithic Settlement in Southern Denmark*, vol. 1328. *Br. Arch. Rep. Int. Ser.* pp. 4–20.
- Steffen, H., Kaufmann, G., Lampe, R., 2014. Lithosphere and upper-mantle structure of the southern Baltic Sea estimated from modelling relative sea-level data with glacial isostatic adjustment. *Solid Earth* 5, 447–459. <https://doi.org/10.5194/se-5-447-2014>.
- Svensson, N.-O., 1989. Late Weichselian and Early Holocene Shore Displacement in the Central Baltic, Based on Stratigraphical and Morphological Records from Eastern Smaland and Gotland, vol. 25. Lund University, Sweden, p. 195. LUNDQUA Thesis.
- Svensson, N.-O., 1991. Late Weichselian and early Holocene shore displacement in the central Baltic Sea. *Quat. Int.* 9, 7–26.
- Tauber, H., 1966. Copenhagen radiocarbon dates VII. *Radiocarbon* 8, 213–234.
- Tolonen, K., Tolonen, K.K., 1988. Synchronous pollen changes and traditional land use in South Finland, studied from three adjacent sites: a lake, a bog and a forest soil. In: *Lake, Mire and River Environments during the Last 15,000 Years. Proceedings of the INQUA/IGCP 158 Meeting on the Palaeohydrological Changes during the Last 15,000 Years*, Bern. A. A. Balkema, Rotterdam, pp. 83–97. June 1985.
- Trimonis, E., Gulbinskas, S., Blazauskas, N., Kuzavinis, M., 2007. Composition and formation of sand massifs in the Curonian–Sambian submarine plateau (Baltic Sea). *Geologija* 60, 39–50.
- Tuomi, L., Kahma, K.K., Pettersson, H., 2011. Wave hindcast statistics in the seasonally ice-covered Baltic Sea. *Boreal Environ. Res.* 16, 451–472.
- Tushingham, A.M., Peltier, W.R., 1992. Validation of the ICE-3G model of warm-Wisconsin deglaciation using a global data base of relative sea level histories. *J. Geophys. Res.* 97 (B3), 3285–3304.
- Tushingham, A.M., Peltier, W.R., 1993. Relative Sea Level Database. IGBP PAGES/World Data Center-A for Paleoclimatology Data Contribution Series # 93-016. NOAA/NGDC Paleoclimatology Program, Boulder CO, USA.
- Uścinowicz, S., Miotk-Szpiganowicz, G., Gaika, M., Pawlyta, J., Piotrowska, N., Pomian, I., M. W., 2013. The rise, development and destruction of the medieval port in Puck in the light of palaeoclimatic and sea level changes research. *Archeol. Pol.* 49, 87–104.
- Uścinowicz, S., Miotk-Szpiganowicz, G., Krapiec, M., Witak, M., Harff, J., Lübke, H., Tauber, F., 2011. Drowned forests in the Gulf of Gdańsk (southern Baltic) as an

- indicator of the holocene shoreline changes. In: Harff, J., Björck, S., Hoth, P. (Eds.), *The Baltic Sea Basin*. Springer-Verlag, Berlin-Heidelberg, pp. 221–234.
- Vassiljev, J., Saarse, L., Grudzinska, I., Heinsalu, A., 2015. Relative sea level changes and development of the Hiiumaa Island, Estonia, during the Holocene. *Geol. Quat.* 59, 517–530. <https://doi.org/10.7306/gq.1227>.
- Veinbergs, I., 1996. *The History of Development of the Baltic Basin in the Final Stage of the Glacial and the Post-glacial, Based on Material from Research at the Latvian Coast and Adjacent Seabed (In Latvian)*. University of Latvia, Institute of Geology.
- Veski, S., 1998. *Vegetation history, human impact and palaeo-geography of West Estonia. pollen analytical studies of lake and bog sediment (PhD thesis)*. *Striae* 38, 1–119.
- Veski, S., Heinsalu, A., Klassen, V.e. a., 2005. Early holocene coastal settlements and palaeoenvironment on the shore of the Baltic Sea at Pärnu, southwestern Estonia. *Quat. Int.* 130, 75–85.
- Vestøl, O., Ågren, J., Steffen, H., Kierulf, H., Tarasov, L., 2019. NKG2016LU: a new land uplift model for Fennoscandia and the Baltic Region. *J. Geodes.* 93, 1759–1779.
- Wessel, P., Smith, W.H.F., 1998. New, improved version of the generic mapping Tools released. *EOS Trans. AGU* 79, 579. <https://doi.org/10.1029/98EO00426>.
- Winn, K., Averdieck, F.R., Erlenkeuser, H., Werner, F., 1986. Holocene sea level rise in the western Baltic and the question of isostatic subsidence. *Meyniana* 38, 61–80.
- Walker, M., Johnsen, S., Rasmussen, S., Popp, T., Steffensen, J.P., Gibbard, P., Hoek, W., Lowe, J., Andrews, J., Björck, S., Cwynar, L., Hughen, K., Kershaw, P., Kromer, B., Litt, T., Lowe, D., Nakagawa, T., Newnham, R., Schwander, J., 2009. Formal definition and dating of the GSSP (Global Stratotype Section and Point) for the base of the Holocene using the Greenland NGRIP ice core, and selected auxiliary records. *J. Quat. Sci.* 24, 3–17.
- Wallin, J.-E., 1994. Den fasta jordbruksnäringens utveckling i Angermanalvens nedre dalgång under järnaldern och medeltiden. *Acta Antiq. Ostrob.* 3, 127–154.
- van Wirdum, F., Andrén, E., Wienholz, D., Kotthoff, U., Moros, M., Fanget, A.S., Seidenkrantz, M.S., Andrén, T., 2019. Middle to Late Holocene variations in salinity and primary productivity in the central Baltic Sea: a multiproxy study from the Landsort deep. *Frontiers in Marine Science* 6. UNSP 51.
- Wessel, P., Luis, J.F., Uieda, L., Scharroo, R., Wobbe, F., Smith, W.H.F., Tian, D., 2019. The generic mapping Tools version 6. G-cubed 20, 5556–5564. <https://doi.org/10.1029/2019GC008515>.
- Wu, P., Wang, H., Steffen, H., 2013. The role of thermal effect on mantle seismic anomalies under Laurentia and Fennoscandia from observations of Glacial Isostatic Adjustment. *Geophys. J. Int.* 192, 7–17.
- Yu, S., Berglund, B., Sandgren, P., Lambeck, K., 2007. Evidence for a rapid sea-level rise 7600 yr ago. *Geology* 35, 891–894.
- Yu, S.-Y., Andrén, E., Barnelov, L., Berglund, B., Sandgren, P., 2003. Holocene palaeoecology and shoreline displacement on the Biskopsmala peninsula, south-eastern Sweden. *Boreas* 32, 578–589. <https://doi.org/10.1080/03009480310004161>.
- Yu, S.-Y., Berglund, B., Sandgren, P., Fritz, S., 2005. Holocene palaeoecology along the Blekinge coast, SE Sweden, and implications for climate and sea-level changes. *Holocene* 15, 278–292. <https://doi.org/10.1191/0959683605h1792rp>.
- Žulkus, V., Girinninkas, A., 2012. Baltijos jūros krantai prieš 10 000 metų (“Yoldia”). *Klaipėdos universiteto leidykla* 55 (in Lithuanian).