

# Comparative performance of six planter attachments in two residue management corn production systems

V. Dadi and M. H. Raoufat\*

*Department of Farm Machinery Engineering, College of Agriculture, Shiraz University, Shiraz, Iran*

## Abstract

Field performance of six combinations of planter attachments on a conventional row-crop planter in two residue management corn production systems was evaluated. The management systems consisted of baled-out residue plots worked by a single pass of disc harrow (RMS1) or untouched residue plots worked by a single pass of chisel plow followed by a disc harrow (RMS2); both systems were planted by a row crop planter with one out of six attachments. Results revealed that both systems fell within residue cover limits defined for conservation farming. The winged chisel furrow opener preceded by a row cleaner equipped with treader wheels (WCRT) arrangement removed appreciable amounts of residues on the row for both systems, but more residues were removed for RMS2 plots. The WCRT pushed almost double amount of residue aside. In spite of higher initial residue in RMS2, chisel plowing and subsequent disc harrowing reduced more residues paving the way for planting in a more seeding depth. Higher percentage of emergence rate index was noticed for RMS2 plots. For both systems, the WCRT and chisel furrow opener preceded by a row cleaner (CR) showed the maximum and minimum quality of feed index, respectively. However this index was higher for RMS2 plots. The WCRT and CR arrangements had the minimum and the maximum multiple index values, respectively. However this index decreased significantly in RMS2 plots compared to RMS1 plots. The RMS2 treatments showed lower values of precision index, which is favorable. The results suggest that adoption of WCRT to planters in soil prepared under RMS2 is useful for a satisfactory conservation crop production system.

**Additional key words:** conservation agriculture; furrow opener; row cleaner; row-cop planter; treader wheels.

## Resumen

### Comparación del comportamiento de seis acoplamientos a una sembradora en dos sistemas de manejo de residuos en la producción de maíz

Se evaluó el comportamiento en campo de seis acoplamientos de elementos de siembra montados sobre una sembradora convencional en surcos con dos sistemas de manejo de residuos (RMS1 y RMS2) para un cultivo de maíz: RMS1 se aplicó a parcelas cuyos residuos fueron empacados mediante un único pase de grada de discos; RMS2 consistió en un pase de arado cincel sobre los residuos sin tratar, seguido de un pase de grada de discos; en ambos sistemas la sembradora llevaba uno de seis diferentes acoplamientos. El abresurcos de reja escarificadora equipada con aletas laterales precedido por un separador de residuos y ruedas acondicionadoras (WCRT) desplazó cantidades apreciables de residuos en los surcos de ambos sistemas, pero en mayor cantidad en las parcelas RMS2. El WCRT desplazó lateralmente casi el doble de la cantidad de residuos. A pesar de haber inicialmente más residuos en RMS2, el arado de cincel y el posterior pase de grada de discos redujeron la cantidad de residuos, preparando el terreno para sembrar a una mayor profundidad. En las parcelas RMS2 hubo un índice de emergencia superior. Para ambos sistemas, el WCRT y el abresurcos de cincel precedido por el separador de residuos (CR) mostraron la máxima y mínima calidad del índice de alimentación, respectivamente. Sin embargo, este índice fue más alto en las parcelas RMS2. WCRT y CR provocaron, respectivamente, los valores mínimo y máximo del índice múltiple; sin embargo, este índice disminuyó significativamente en RMS2 frente a RMS1. RMS2 presentó el menor índice de precisión, lo cual resulta ventajoso. Los resultados sugieren que la incorporación del WCRT en las sembradoras en hileras en suelos preparados con el sistema RMS2 resulta útil para la producción con agricultura de conservación.

**Palabras clave adicionales:** abridor de surcos; agricultura de conservación; ruedas de acondicionadoras; sembradora en surcos; separador de residuos.

## Introduction

One of the important concerns encountering in conservation agricultural systems is non-uniformity in seed spacings and amount of residues retained when using conventional crop production systems in fields with previous residue. Siemens & Wilkins (2006) reported that both stand establishment and seedling dry weight in residue baled-out levels are significantly higher than those for untouched residue fields. A number of studies have found that conservation tillage compared to conventional tillage could increase soil water and minimize soil erosion, and soil temperature fluctuations (Triplett & Doren, 1977; Wall & Stobbe, 1984; Dick *et al.*, 1991; Wagger & Denton, 1992).

Crop residues like wheat straw and corn stalk are considered as renewable biomass. Crop residues in a bio-refinery save greenhouse gas emission (GHG) and residue fossil energy demand (Cherubini & Ulgiati, 2009). Raoufat & Matbooei (2007) developed a star wheel row cleaner for residue management and cleaning crop residue on seed rows. They reported that the row cleaner removed 70% of wheat straw residue on the row band which resulted in a significant improvement in soil-seed contact. Straw residue with adequate amount of organic material has important function in terms of improvement in soil structure and stability (Morris *et al.*, 2010). According to Erbach (1981) and Raoufat & Mahmoodieh (2005), to overcome the seed placement problems and improving seed indices in agricultural conservation systems row-crop planters should be equipped with rolling cultures. Sanavi & Raoufat (2006) found desirable values of emergence rate and seed spacing by equipping a conventional row-crop planter with a winged chisel furrow opener preceded by a row cleaner attachment arrangement. Fallahi & Raoufat (2008) evaluated field performance of a conventional row-crop planter with three types of planter attachment (plain rolling coulter, row cleaner and a row cleaner followed by plain rolling coulter) in three tillage systems (single pass of disc harrow, three passes of disc harrow and single pass of disc harrow followed by chisel plowing). They reported

that row-crop planter equipped with row cleaner followed by rolling coulter increased quality of feed index (QFI); the improvement amounted to 37.7%. Recently a farm machinery manufacturer introduced a row cleaner equipped with aluminum treader wheels claiming that the new combination prevents the row cleaner wheels trenching within soft soil and hence improving cleaner performance residue (Martin Company Inc., 2009-2010). Treader wheels provide traction to help keep the row cleaner turning in heavy residue (Martin Company Inc., 2009-2010). According to Needham (2009) adding aluminum treader wheels to row cleaner allows the unit to be carried across softer areas of the soil surface and contours of the ground without gouging.

No previous study has been undertaken to evaluate combinations of row cleaner and furrow opener with treader wheels. Therefore the main objective of this study was to evaluate field performance of six planter attachment arrangements in two residue management systems (RMSs) at two forward speeds considering the amount of residue after planting, seeding depth, emergence rate index (ERI), quality of feed, multiple, miss and precision indices.

## Material and methods

### Description of the row-crop planter & planter attachments used in this study

A single unit row crop planter simulating a typical four row crop planter was equipped with appropriate conservation farming tools to accomplish the treatment envisaged in this study. The seed metering system was adjusted for a theoretical seed spacing of 10 cm. Before field operation row-crop planter was calibrated in the laboratory.

As mention earlier, furrow openers can play an important role in providing proper seed placement depth, especially in agricultural conservation systems. Three types of furrow opener were used: chisel, winged chisel and double disc furrow opener.

---

Abbreviations used: CR (chisel furrow opener preceded by row cleaner attachment); CRT (chisel furrow opener preceded by row cleaner equipped treader wheels attachment); DPA (number of days after planting); DR (double disc furrow opener preceded by a row cleaner attachment); DRT (double disc furrow opener preceded by row cleaner equipped treader wheels attachment); EMG (percentage of seeds planted emerged on the day); ERI (Emergence rate index); QFI (quality of feed index); RMS (residue management system); WCR (winged chisel furrow opener preceded by a row cleaner attachment); WCRT (winged chisel furrow opener preceded by a row cleaner equipped treader wheels attachment).

Chisel furrow opener used was fabricated from high-carbon steel plates 5 mm thick and with 30° rake angle. Edges sharpened winged chisel furrow opener cut residue on rows and push them aside. Winged chisel furrow opener was fabricated from high carbon steel plates 5 mm thick. The winged chisel with 30° rake angle and two 5 mm width bottom beveled wings which were downward 45°. The front blade could cut soil 25-30 mm deeper than the wings. Sharp edge winged chisel can be cutting and pushing more residue asides (Sanavi Shiri & Raoufat, 2006). Double disc furrow opener with two 350 mm diameter plain plates placed at a 30° angle to each other. Plates were made from 1.5 mm thick high-carbon steel and were sharpened to 14°. Furrow openers were bolted to the steel shank which was hitched to row-crop planter frame (Fig. 1).

In agricultural conservation systems, row cleaners clean trash and residue on the row and are believed to improve seed spacing indices significantly. Row cleaner was made of two 25 cm diameter free rotating thin wheels placed at a 45° angle against each other. The row cleaner attachment was installed in front of the furrow opener to clean rows from previous residue. Row cleaner assembly comprised of a pivot joint and spring loaded link, providing suitable floatation.

The conical treader wheels were fabricated from aluminum with larger and smaller diameters of 200 and 170 mm, respectively. The treader wheels were fabricated in conical shape to promote residue removal to the row boundaries (Fig. 1).

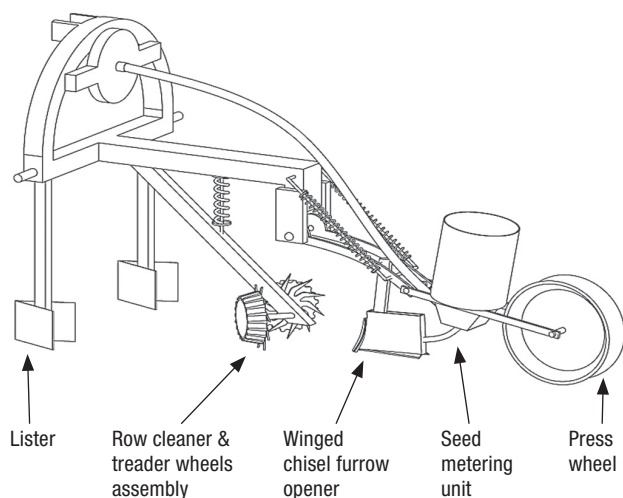

**Figure 1.** Schematic diagram of the mounted pneumatic row-crop planter equipped with row cleaner & treader wheels and winged chisel furrow opener used in this study.

## Residue management systems

The residue management systems consisted of baled-out residue plots worked by a single pass of disc harrow (RMS1) or untouched residue plots worked by a single pass of chisel plow followed by a disc harrow (RMS2); both systems were planted by a row crop planter with one out of six attachments. The average amount of irrigated wheat residue before tillage operation for untouched and baled-out residue were 5.85 and 4.09 t ha<sup>-1</sup>, however the amount of residues after tillage operations for non-baled and baled plots were measured and found to be 1.75 and 2.69 t ha<sup>-1</sup>, respectively.

The disc harrow used was an offset 24 blade 90 cm in diameter with notched discs on the front gang and plain discs on the rear gang. Its working width and depth were 2.46 m and 10 cm, respectively. The spring loaded chisel plow used (9 shank, 20° rake angle) was equipped with curved shanks. Its working width and depth were 2.5 m and 20 cm, respectively.

## Experimental design

A split-split-plot experiment arranged as a randomized complete block design was conducted with three replications. A conventional pneumatic row-crop planter equipped with one out of the attachment arrangements was used to plant in two RMSs (RMS1 and RMS2, see above) and two forward speeds. The split-level was furrow opener attachment arrangements, as chisel furrow opener preceded by row cleaner attachment (CR), chisel furrow opener preceded by row cleaner equipped treader wheels attachment (CRT), winged chisel furrow opener preceded by a row cleaner attachment (WCR) and winged chisel furrow opener preceded by a row cleaner equipped treader wheels attachment (WCRT), double disc furrow opener preceded by a row cleaner attachment (DR), and double disc furrow opener preceded by row cleaner equipped treader wheels attachment (DRT). The sub-split-level was plant forward speed in two levels (7 and 10 km h<sup>-1</sup>). The plots dimensions were 15 m × 3 m.

Field experiments were established in summer 2010 at the Agricultural Research Station, Shiraz University located in NW Shiraz, Iran (52°32' E, 36°29' N and 1810 m asl). Corn hybrid SC-704 with 1000 kernel weight of 250 g, emergence rating of 92% and purity of 98% was planted using a conventional pneumatic single seed type row-crop planter equipped with listers.

## Measurements

**Soil properties.** Soil moisture and bulk density were measured by taking 20 soil samples at 0-20 cm of depth before tillage operations. The soil samples were weighted and dried in an oven at a temperature of 105°C for 24 h. The average moisture content and mean dry bulk density were 9% (db) and 14.3 kN m<sup>-3</sup>, respectively. The soil was composed of 17.8% sand, 48% silt and 34% clay classified as clay-loam.

**Residue measurement technique.** In order to measure the quantity of wheat residue per unit area a 0.5 m × 0.5 m frame measuring system was used. Residue in frame was collected and dried in an oven at temperature of 105°C for 24 h. Then quantity of residue per unit area was calculated and found to be 0.25 m<sup>2</sup>. Quantity of residue before and after tillage operations were measured by taking 10 samples in each plot.

**Seeding depth.** In order to measure seeding depth, a special tube was developed with one edge sharpened to help pull seedlings out of the soil. The seedlings were washed and the length of the mesocotyl was measured by a digital caliper. Since nodal roots typically grow approximately 2 cm below the soil surface, an extra 2 cm was added to obtain seed placement depth (Ritchie *et al.*, 1993).

**Emergence rate index (ERI).** The ERI is an indication of how fast and uniform in time the crop emerges from the soil (Staggenborg *et al.*, 2004). Erbach (1982) suggested the use of Eq. [1] for computing % ERI:

$$ERI = \sum_{n-1}^x \frac{EMG_n - EMG_{n-1}}{DAP_n} \quad [1]$$

where  $n$  is the emergence observation,  $EMG_n$  is the percentage of seeds planted emerging on the day of the  $n^{\text{th}}$  emergence observation and  $DPA_n$  is the number of days after planting when the  $n^{\text{th}}$  emergence observation was taken. The number of plants emerged in mid-6 m length of each row were counted after 3, 4, 5, 7, 9, 12, 14, 17, 20 and 25 days after planting and stopped when no further increased in emerged counts was observed.

**Uniformity of seed spacings.** For determining uniformity of seed spacings ISO standard (1984) was adopted as suggested by Kachman & Smith (1995). The distance between seedlings  $x_{\text{ref}}$  is the theoretical spacing which is used to divide the observed spacings into five regions:  $[0, 0.5x_{\text{ref}}]$ ,  $(0.5x_{\text{ref}}, 1.5x_{\text{ref}}]$ ,  $(1.5x_{\text{ref}}, 2.5x_{\text{ref}}]$ ,  $(2.5x_{\text{ref}}, 3.5x_{\text{ref}}]$  and  $(3.5x_{\text{ref}}, \infty)$ . The five regions correspond respectively to the following classification of

regions: (1) a multiple, closer to the previous plant than the theoretical spacing; (2) a single, closer to the theoretical spacing than either the previous plant or a single skip; (3) a single skip, closer to a single skip than either the theoretical spacing or a double skip; (4) a double skip; and (5) a triple or more skips. The plant spacings which fall in the second region are considered as correct spacings. These measures are defined in the following sections:

— Multiple index is the percentage of plant spacings that are less than or equal to half the theoretical spacing. Smaller value of multiple index indicates better planter performance than larger values.

— Miss index is the percentage of plant spacings that are 1.5 times larger than the theoretical spacing. Similarly, a smaller value of miss index indicates better planter performance than larger values.

— Quality of feed index (QFI) is the percentage of plant spacings that are more than half and less than or equal to 1.5 times the theoretical spacing. Greater values QFI is a sign of better planter performance than smaller values. In other words, QFI is a measure of how often the spacings are close to the theoretical spacing (Kachman & Smith, 1995). For example a QFI of 70% means that 70% of the spacings are not classified either as multiples or skips.

— Precision is a measure of the variability in spacing between plants after accounting for variability due to both multiples and skips. Smaller value of precision indicates better performance than larger values. The theoretical upper limit for precision is 50% and this distribution spacing would indicate that the theoretical spacing was incorrectly specified and, therefore, this theoretical level is unfavorable. A practical upper limit on the value of precision is 29%. While there is a theoretical upper limit of 50% on the precision, values consistently larger than 29% should be viewed with suspicion (Kachman & Smith, 1995).

In this research, the theoretical plant spacing was considered to be 10 cm, which is a common local practice. Therefore the multiple index is the percentage of spacings that are  $\leq 5$  cm, the miss index is the percentage of spacings that are  $> 15$  cm and QFI is the percentage of spacings that are  $> 5$  cm and  $\leq 15$  cm.

## Data analyses

Analysis of variance to detect significant differences and comparison of means were performed using SPSS package.

## Results and discussion

### Surface residue after planting operation

Analyses of the variance of data on residue retained after planting operation as affected by various treatments and their interactions indicated that only interaction of RMS, attachment arrangement and forward speed significantly affected this index. No interaction was found between RMSs, attachment arrangement and forward speed.

According to McCarthy *et al.* (1999) at least 621 kg ha<sup>-1</sup> of residues equal to 30% surface coverage is needed for small grain such as wheat to establish soil conservation tillage system. In the present study, the amount of residues retained before and after tillage and after planting operations on each row for all the treatments was more than 621 kg ha<sup>-1</sup> (Table 1). It can be concluded that the treatments envisaged for the present study fall within residue cover limits defined for conservation farming practices.

Comparison of means of data on this index showed that for both RMSs, the mean values of WCRT retained the lowest amount of residue on the seed row after planting (Table 1). The winged chisel furrow opener preceded by a row cleaner equipped with treader wheels (WCRT) in RMS1 plots removed 20% of wheat residue on the row band as compared to similar plots worked with CR attachment (Table 1). Whereas, the WCRT arrangement in RMS2 plots removed 27% of wheat residue on the row band as compared to CR attachment (Table 1). The reason is that the treader wheels rotation have pushed aside residue on the row, the subsequent winged-chisel has pushed further residue asides. Comparing the overall means of amount of residue retained indicated that for both RMSs, increase in forward speed from 7 to 10 km h<sup>-1</sup> resulted in significant residue removal on the row band as seen in Table 1.

### Effects on seeding depth

Analysis of variance of the data on seeding depth indicated that RMS, attachment arrangement and forward speed have significant effects on this index. No interaction was found between tillage and RMSs, type of attachment arrangement and speed levels as far as seeding depth is concerned.

Comparison of the means of seeding depth (Table 1) indicated that regardless of type of attachment, seeding

depth increased from 4.37 to 4.93 cm as tillage operation increased in RMS2 treatments. Although RMS2 treatments were applied to a soil with higher initial residue, the chisel plowing and subsequent disc harrowing reduced the residue retained to average 950 kg ha<sup>-1</sup>, which in turn can pave the way for planting in a more seeding depth.

Comparison of the data means on seeding depths (Table 1) indicate that for both RMSs, increase in forward speed resulted in less seeding depth, not necessarily in a significant manner. The reason may be less furrow opener penetration at a higher speed level.

For both RMSs, WCRT and CR attachment resulted in the highest and the lowest seeding depth, respectively (Table 1). Comparison of data revealed that WCRT treatment performed better in RMS2. This improvement in seeding depth may be due to fewer residues retained in this RMS.

### Effects on emergence rate index (ERI)

Analysis of variance of the data on ERI indicated that RMSs, attachment arrangement and forward speeds have significant effects on this index. There was no significant interaction between RMSs, attachment arrangement and forward speed.

Higher soil temperature due to lower surface residue resulted in higher % ERI in RMS2 plots as compared to RMS1 ones; average improvement up to 14% was noticed (Table 1). Table 1 also shows that for both RMSs, WCRT and CR were associated with the highest and the lowest % ERI, respectively. Higher % ERI may be attributed to less residues retained due to rotation of row cleaner equipped with treader wheels and also sharpened edge winged chisel furrow opener which could remove further residue, resulting in a higher soil temperature (Table 1). This finding is similar to that of Wicks *et al.* (1994) who stated that higher surface residue cause further reduction in soil temperature and thus slow emergence. The higher % ERI for RMS2 plots may be due to fewer residues retained on the soil in this RMS.

### Effects on seeding indices

Data on seedling spacings were used to calculate the following four indices of spacing.

**Table 1.** The effect of forward speed, planter attachments and residue management systems (RMS) on residue retained after planting, seeding depth, emergence rate index (ERI) and seeding indices

Planter attachments <sup>1</sup>	Residue management systems <sup>2</sup>					
	RMS1			RMS2		
	V <sub>1</sub>	V <sub>2</sub>	Mean	V <sub>1</sub>	V <sub>2</sub>	Mean
Residue retained after planting (t h <sup>-1</sup> )						
CR	1.90a	1.79ab	1.80a	1.20abc	1.05abc	1.12a
CRT	1.78ab	1.46defg	1.62bc	1.02bcd	0.84cd	0.93ab
WCR	1.73abc	1.50cdef	1.61bc	0.98cde	0.86cd	0.92ab
WCRT	1.59bcde	1.28fgh	1.44c	0.89de	0.72d	0.81b
DR	1.88a	1.57bcde	1.73ab	1.06bcd	0.95bcd	1.00ab
DRT	1.68abcd	1.37efg	1.50bc	0.98cde	0.82cd	0.90ab
Mean <sup>3</sup>	1.76A	1.49B		1.02A	0.87B	
Overall mean	1.63A			0.95B		
Seeding depth (cm)						
CR	4.19ghi	3.91f	4.10a	4.69bcdefg	4.49defgh	4.59abc
CRT	4.52defgh	4.09ef	4.31ab	4.88abcde	4.86abcde	4.87bcd
WCR	4.61cdefgh	4.29cdef	4.45abc	5.11abc	4.91abcd	5.01de
WCRT	4.81abcdef	4.45abcde	4.63bcd	5.33a	5.26abc	5.29e
DR	4.37defhi	3.92f	4.14a	4.83abcdef	4.67bcdefg	4.75bcd
DRT	4.71abcdefg	4.35bcdef	4.53bcd	5.20ab	4.9abcde	5.05de
Mean <sup>3</sup>	4.55A	4.18B		5.01A	4.85A	
Overall mean	4.37A			4.93B		
ERI (% day <sup>-1</sup> )						
CR	22.12d	23.97gh	22.77d	25.40ef	30.91cde	26.44def
CRT	23.44bd	28.92cd	24.92cd	30.01abc	35.82a	28.76bd
WCR	24.42bcd	24.45fgh	25.87bcd	23.23fg	24.06bfg	30.76abc
WCRT	25.40bc	33.07ab	27.71abcd	26.41de	32.01bcd	33.36a
DR	25.30bc	28.01de	24.82c	25.22ef	30.33de	28.03cde
DRT	26.42ab	33.52a	27.66abc	30.09abc	33.16b	31.74ab
Mean <sup>3</sup>	24.29A	26.96B		26.95A	32.75B	
Overall mean	25.62A			29.85B		
Multiple index (%)						
CR	33.57f	22.23def	27.90f	27.91fg	20.96def	24.43f
CRT	24.21de	18.77cdef	21.49def	22.90def	15.62abcde	19.26de
WCR	17.92acd	16.17bcde	17.04bcde	15.08abcde	6.33a	10.71ab
WCRT	16.73acd	6.43a	11.58abc	11.16abc	6.12a	8.64a
DR	20.94cde	17.08bcde	19cde	19.85cdef	13.33abcd	16.59bcd
DRT	17.5abcd	16.16bcde	16.83bcde	13.19abcd	8.85ab	11.02ab
Mean <sup>3</sup>	21.81A†	16.14B		18.35A	11.87B	
Overall mean	18.98A			15.12B		
Miss index (%)						
CR	36.29hi	38.94i	37.61f	24.46cdef	30.15fgh	27.31d
CRT	33.98hi	35.71hi	34.84ef	23.91cdef	26.85efg	25.38d
WCR	21.89bcde	21.73bcde	21.81bc	16.59ab	24.19cdef	20.39bc
WCRT	17.92abc	26.14defg	22.03bc	13.45a	14.95ab	14.20a
DR	30.18fgh	31.74gh	30.96de	19.2abcde	24.54cdef	21.87bc
DRT	19.47abcde	17.45abc	18.46ab	15.33ab	19.83abcde	17.58ab
Mean <sup>3</sup>	26.62A	28.62A		18.82A	23.42A	
Overall mean	27.62A			21.12B		

**Table 1 (cont.).** The effect of forward speed, planter attachments and residue management systems (RMS) on residue retained after planting, seeding depth, emergence rate index (ERI) and seeding indices

Planter attachments <sup>1</sup>	Residue management systems <sup>2</sup>					
	RMS1			RMS2		
	V <sub>1</sub>	V <sub>2</sub>	Mean	V <sub>1</sub>	V <sub>2</sub>	Mean
Quality of feed index (%)						
CR	30.14k	38.83j	34.48e	47.63hi	48.89hi	48.26f
CRT	41.81ij	45.52gi	43.67d	53.19gh	57.53fg	55.36e
WCR	60.19cd	62.12bcd	61.15b	68.33cd	69.48bc	68.91c
WCRT	65.35abc	67.43ab	66.39a	75.39ab	78.93a	77.16a
DR	48.89fg	51.18fg	50.03c	60.95ef	62.13de	61.54d
DRT	63.03bcd	66.39abcd	64.71ab	71.48bc	71.32bc	71.40b
Mean <sup>3</sup>	51.57A	55.24A		62.83A	64.71A	
Overall mean	53.41A			63.77B		
Precision (%)						
CR	31.79f	37.70f	34.74d	18.83e	26.65gh	22.47d
CRT	29.95ef	36.99f	33.47d	17.99e	24.97fg	21.48d
WCR	18.83c	28.98de	23.91c	13.45bcd	17.47e	15.46bc
WCRT	12.41ab	15.95a	14.18a	8.09a	10.12ab	9.11a
DR	26.78de	36.01f	31.40d	16.68de	22.38f	19.53cd
DRT	17.33a	24.39bc	20.86b	11.13ab	15.30cde	13.22ab
Mean <sup>3</sup>	22.85A	30B		14.36A	19.48B	
Overall mean	26.42A			15.92B		

<sup>1</sup> CR, chisel furrow opener preceded by row cleaner; CRT, chisel furrow opener preceded by row cleaner equipped with treader wheels; WCR, winged chisel furrow opener preceded by a row cleaner; WCRT, winged chisel furrow opener preceded by a row cleaner equipped with treader wheels; DR, double disc furrow opener preceded by row cleaner; DRT, double disc furrow opener preceded by row cleaner equipped with treader wheels. <sup>2</sup> RMS1: baled residue and merely a single pass of disc harrowing; RMS2: untouched residue and a single pass of chisel plowing followed by disc harrowing. Forward speed: V<sub>1</sub>, 7 km h<sup>-1</sup>; V<sub>2</sub>, 10 km h<sup>-1</sup>. For each parameter, means followed by the same letters are not significantly different at  $p < 0.05$ . Means within each row followed by the same capital letters are not significantly different at  $p < 0.05$ .

### Effects on multiple index

Analysis of variance of data on multiple index indicated that tillage and RMSs, attachment arrangement and forward speed have significant effects on this index. No interaction was found between RMSs, attachment arrangement and forward speed.

Comparison of the data means indicated that multiple index decreased in RMS2 plots as compared to RMS1 plots from 18.9% to 15.1%. That is for the plots worked under RMS2, only 15.1% of the plants were viewed as “dropped at the same time” as the previous plants (Table 1).

Further analysis indicated that increase in forward speed from 7 to 10 km h<sup>-1</sup>, reduced % multiple index for both RMSs, which is desirable. In both RMSs, significant differences in % multiple index were noticed among attachment arrangements and WCRT and CR

arrangements had the lowest and the highest multiple index values, respectively (Table 1).

### Effects on miss index

Analyses of variance of data on miss index as affected by various treatments and their interactions indicated that only interaction of RMSs and attachment arrangement affected this index in a significant manner. Comparison of means of data on miss index indicated lower mean for RMS2 plots compared to those for RMS1 plots (Table 1). Fewer residues in RMS2 plots as a result of more tillage operations and less press wheel slippage are the possible causes of this improvement. Significant difference was also noticed on values of miss index for forward speed levels. Increasing forward speed from 7 to 10 km h<sup>-1</sup>, resulted in increase in miss index for both

systems which is undesirable (Table 1). The high levels of the miss index could be due to a number of factors including the failure of the planter to drop the seed or the failure of the seed to germinate or produce a seedling. Other data indicated that plots with WCRT treatments had the least % miss index for both systems.

#### Effects on quality of feed index (QFI)

Analysis of variance of data indicated that the type of RMS had significant effects on QFI. Mean comparison of overall % QFI indicated that RMS2 treatments resulted in higher % of this index as compared to RMS1 treatments (Fig. 2a). The increase amounts to 16%, which is considerable. The reason may be more tilling operations in RMS2 plots resulting in less surface residue and as a result less wheel slippage. Comparison of the means of data also indicated that RMSs and attachment arrangements studied have significant effects on % QFI (Fig. 2b). Mean comparison of data on QFI for both RMS1 and RMS2 plots revealed that WCRT and CR arrangements have the maximum and minimum values of QFI for both systems, respectively (Table 1). The reasons for high values of QFI in WCRT plots are inclusion of rotation treader wheels which push residue on the row aside; furthermore, sharp edges winged-chisel also helps push more residue asides. Fewer residue on the row results in lower slippage in the planter press wheel which in turn results in higher % of QFI. The average QFI for the RMS2 plots were above 60%, indicating that more than two-third of the spacings

was not classified as multiples or skips, whereas the average QFI for the RMS1 treatments was 53.4% (Table 1).

QFI increased for both RMSs when forward speed increased from 7 to 10 km h<sup>-1</sup>, although this increase was not significant (Table 1).

#### Effects on precision of plants spacing

Analyses of the variance of data on precision index as affected by various treatments and their interactions indicated that only interaction of RMSs and attachment arrangement significantly affected this index. No interaction was found between RMSs, attachment arrangements and forward speed levels.

Comparison of the means of data indicated that reduction in precision values up to 40% was noticed in RMS2 plots as compared to RMS1 ones, which is desirable (Table 1). The reason may be more tillage operations in RMS2 plots, less press wheel slippage, and hence lower standard deviation of the seed spacings.

Table 1 shows that significant differences were found among the values of precision index at different speed levels. Lower values of % precision were found at lower forward speed, this was true for both systems, which is desirable. The lower values of precision index may be attributed to fewer residues retained on plots prepared by RMS2.

Other comparison indicated that WCRT has the lowest value for precision for both RMSs. Further comparison indicated that WCRT and CR arrangement have the lowest and the highest precision indices for RMS1

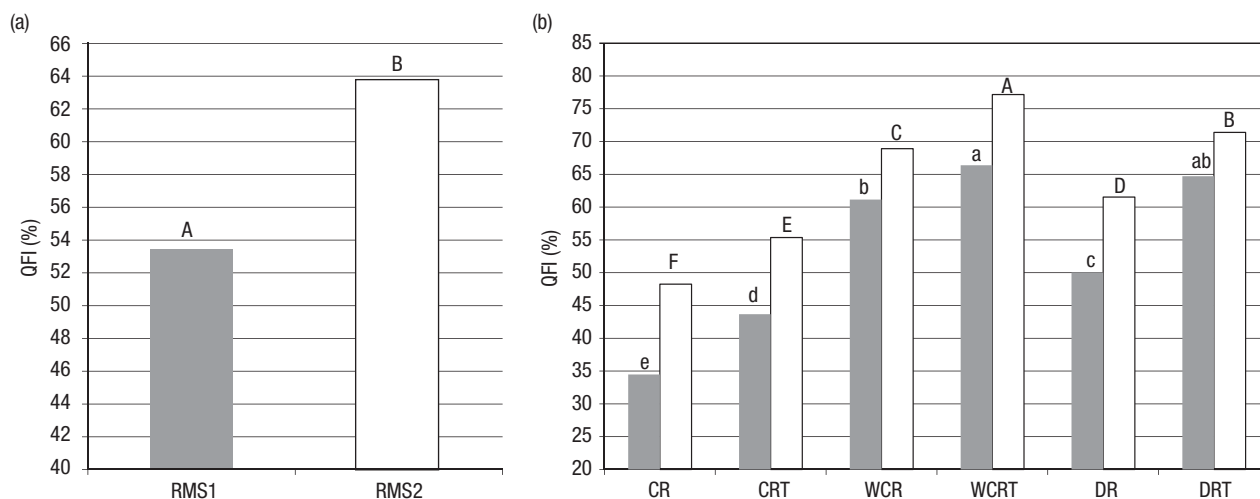

**Figure 2.** Overall (a) and mean (b) of various planter attachments of per cent quality of feed index (QFI) for the two residue management systems (RMS) experienced (see Table 1). Columns with same lower or upper case letters are not statistically different at  $p = 0.05$ . Grey histograms: RMS1. White histograms: RMS2.



and RMS2 plots, respectively (Table 1). The range of the precision index observed for the RMS2 treatments was roughly 12-32%, where similar data for RMS2 treatment were 9-22%, indicating that planter performance was close to the recommended value of 29% (Kachman & Smith, 1995). Therefore it can be concluded that in this study, the spacings were spread uniformly within the target range, however, RMS2 treatments showed lower values of this index, which is favorable.

The study showed that both RMSs included in the present study fell within residue cover limits defined for establishing conservation farming practices and the WCRT arrangement successfully removes appreciable amounts of residue on the row for both systems, as expected more residues have been removed for RMS2 plots. Other results show that as the forward speed increases more residues are removed. In spite of higher initial residue level in RMS2 treatments, chisel plowing and subsequent disc harrowing reduced more residues paving the way for planting in a more seeding depth. For both RMSs, increases in forward speed resulted in less seeding depth. Generally QFI was higher for RMS2 plots. The WCRT and CR arrangements showed the desirable and the worst for both multiple and QFI indices, respectively. Increasing forward speed resulted in higher miss index for both systems, which is undesirable.

As final conclusions, the study suggests that addition of WCRT attachment arrangement to conventional planters in soil prepared under RMS2 is useful for a satisfactory soil conservation crop production system.

## Acknowledgement

The authors wish to thank Research Council of Shiraz University, Shiraz, Iran, for providing necessary funds and research facilities required for this investigation.

## References

- Cherubini F, Ulgiati S, 2009. Crop residue as raw materials for bio-refinery systems, a LCA case study. *Appl Energ* 87: 47-57.
- Dick WA, McCoy EL, Edwards WM, Lal R, 1991. Continuous application of no tillage to Ohio soils. *Agron J* 83: 65-73.
- Erbach DC, 1981. Planting for corn production with conservation. In: *Crop production with conservation in the 1980s*. ASAE Publ 7-81. St. Joseph MI, USA, pp: 50-56.
- Erbach DC, 1982. Tillage for continuous corn and corn-soybean rotation. *T ASAE* 25: 906-911.
- Fallahi S, Raoufat MH, 2008. Row-crop planter attachments in a conservation tillage system: A comparative study. *Soil Till Res* 98: 27-34.
- ISO, 1984. Sowing equipment-Test methods. Part 1. Single seed drills (precision drills) [7256/1]. International Organization for Standardization, Geneva, Switzerland.
- Kachman SD, Smith JA, 1995. Alternative measure of accuracy in plant spacing for planter using single seed metering. *T ASAE* 38: 379-387.
- Martin Company, 2009. Martin-Till™ Planting System. Available in [http://flatrockprecision.com/yahoo\\_site\\_admin/assets/docs/Martin-Till\\_Row\\_Cleaners\\_2009-10.3960215.pdf](http://flatrockprecision.com/yahoo_site_admin/assets/docs/Martin-Till_Row_Cleaners_2009-10.3960215.pdf). [16 December 2010].
- McCarthy JR, Pfoest DL, Currence HD, 1999. Conservation tillage and residue management to reduce soil erosion. *Agr Publ G1650*, Univ Extens, Univ of Missouri, Columbia, MO, USA.
- Morris NL, Miller PCH, Orson JH, Froud-Williams RJ, 2010. The adoption of non-investigation tillage systems in the United Kingdom and the agronomic impact on soil, crops and the environment-A review. *Soil Till Res* 108: 1-15.
- Needham Ag Technologies, 2009. LLC-4911. Wheat Manage Publ, Calhoun, KY, USA. Available in [www.needhamag.com](http://www.needhamag.com). [8 October 2009].
- Raoufat MH, Mahmoodieh RA, 2005. Stand establishment response of maize to seedbed residue, seed drill coulters and primary tillage systems. *Biosyst Eng* 90: 261-269.
- Raoufat MH, Matbooei A, 2007. Row cleaners enhance reduced tillage planting of corn in Iran. *Soil Till Res* 93: 152-161.
- Ritchie W, Hanway JJ, Benson GO, 1993. How a corn plant develops. CES special report No. 48, Iowa Stat Univ, Ames, IA, USA. 21 pp.
- Sanavi Shiri N, Raoufat MH, 2006. Comparative performance of four planter furrow opener and row cleaner arrangements in a conservation tillage corn production system. *Iran Agr Res* 25(1): 53-66.
- Siemens MC, Wilkins DE, 2006. Effect of residue management methods on no-till drill performance. *Appl Eng Agr* 22(1): 51-60.
- Staggenborg SA, Taylor RK, Maddux LD, 2004. Effect of planter speed and seed firmer on corn stand establishment. *T ASAE* 20(5): 573-580.
- Triplett GB, Doren DM, 1977. Agriculture without tillage. *Sci Am* 236: 28-33.
- Wagger MG, Denton HP, 1992. Crop and tillage rotations: grain yield, residue cover, and soil water. *Soil Sci Soc Am J* 56: 1233-1237.
- Wall DA, Stobbe EH, 1984. The effect of tillage on soil temperature and corn (*Zea mays* L.) growth in Manitoba. *Can J Plant Sci* 64: 59-67.
- Wicks GA, Cruchfield A, Burnside O, 1994. Influence of wheat (*Triticum aestivum*) straw mulch on metolachlor corn (*Zea mays*) growth and yield. *Weed Sci* 1: 141-147.