



Investigating the Swelling Pressure of Compacted Crushed-Callovo-Oxfordian Claystone

Chaosheng Tang, Anh Minh Tang, Yu-Jun Cui, Pierre Delage, Christian
Schroeder, Emmanuel De Laure

► To cite this version:

Chaosheng Tang, Anh Minh Tang, Yu-Jun Cui, Pierre Delage, Christian Schroeder, et al.. Investigating the Swelling Pressure of Compacted Crushed-Callovo-Oxfordian Claystone. *Physics and Chemistry of The Earth*, Elsevier, 2011, 36 (17-18), pp.1857-1866. <10.1016/j.pce.2011.10.001>. <hal-00655750>

HAL Id: hal-00655750

<https://hal-enpc.archives-ouvertes.fr/hal-00655750>

Submitted on 2 Jan 2012

HAL is a multi-disciplinary open access archive for the deposit and dissemination of scientific research documents, whether they are published or not. The documents may come from teaching and research institutions in France or abroad, or from public or private research centers.

L'archive ouverte pluridisciplinaire **HAL**, est destinée au dépôt et à la diffusion de documents scientifiques de niveau recherche, publiés ou non, émanant des établissements d'enseignement et de recherche français ou étrangers, des laboratoires publics ou privés.

1 **Investigating the Swelling Pressure of**
2 **Compacted Crushed-Callovo-Oxfordian Claystone**

3 C. S. Tang ^{1,2}, A. M. Tang ², Y. J. Cui ², P. Delage ², C. Schroeder ³, E. De Laure ²

4
5 ¹ *School of Earth Sciences and Engineering, Nanjing University, Hankou Road 22, Nanjing, China*
6 (tangchaosheng@nju.edu.cn)

7 ² *Ecole des ponts - ParisTech, U.R. Navier/CERMES, 6-8 av. Blaise Pascal, Cité Descartes,*
8 *77455 MARNE-LA-VALLEE, France* (tang@cermes.enpc.fr; yujun.cui@enpc.fr;
9 delage@cermes.enpc.fr; delaware@cermes.enpc.fr)

10 ³ *ANDRA, 92298 Châtenay-Malabry Cedex, France* (Christian.Schroeder@andra.fr)

11
12
13
14
15
16
17
18
19
20
21
22
23 Corresponding author:

24
25 Prof. Yu-Jun CUI
26 Ecole des Ponts ParisTech
27 6-8 av. Blaise Pascal, Cité Descartes, Champs-sur-Marne
28 77455 Marne-la-Vallée cedex 2
29 France

30
31 Email : yujun.cui@enpc.fr
32

1 **Abstract**

2 This paper presents an experimental study on the swelling pressure of heavily
3 compacted crushed Callovo-Oxfordian (Cox) claystone at a dry unit mass $\rho_d =$
4 2.0 Mg/m^3 using four different methods: constant-volume, swell-reload, zero-swell
5 and adjusted constant-volume method. Results show that the swelling pressure varies
6 in the range of 1-5 MPa and depends significantly on the test method. From the
7 constant-volume tests, it is observed that the swelling behaviour during wetting is a
8 function of the suction and depends on both the hydration paths and wetting
9 conditions (e.g. vapour-wetting or liquid-wetting). The swelling pressure decreases
10 significantly with saturation time. To identify the microstructure changes of
11 specimens before and after wetting, mercury intrusion porosimetry (MIP) and
12 scanning electron microscopy (SEM) tests were performed. It is observed that, after
13 wetting, the large inter-aggregate pores observed in the as-compacted specimen are no
14 longer apparent; the whole pattern is characterized by a general swell of hydrated clay
15 particles, rendering the soil more homogeneous. Results from MIP indicated that
16 wetting caused a significant reduction of the entrance diameter of the dominant
17 inter-aggregate pores from 2.1 to 0.5 μm whereas intra-aggregate pores were not
18 significantly influenced.

19
20 **Keywords:** crushed Callovo-Oxfordian claystone; swelling pressure; hydration path;
21 microstructure; suction; laboratory tests.

22 23 24 25 **1. Introduction**

26 Deep clay or claystone formations are considered as potential host rock for
27 radioactive waste disposal in many countries such as Belgium, Germany, France,
28 Japan and Switzerland. In order to ensure the overall safety of the storage system, it is
29 of prime importance to develop a good understanding of the clay properties involved
30 for different time scales: i.e. during construction of the repository as well as its
31 long-term isolation performance (Landais and Aranyossy 2007). In addition to the
32 coupled thermo-hydro-mechanical behaviour of the host rock, the engineering
33 properties of backfilling/sealing materials are also an important issue to investigate
34 because these materials play a critical role in reducing migration of water, gas and
35 radionuclides to an acceptable low level.

36 In the past decades, bentonite has been widely studied as backfilling and sealing
37 material because of its low permeability, adequate self-sealing potential and high
38 water retention capacity (Marcial et al. 2002, Lloret et al., 2003; Tang and Cui, 2005;
39 Hoffman et al., 2007; Tang et al., 2008a and 2008b; etc.).

40 The use of crushed excavated COx claystone as a possible backfilling/sealing
41 material to isolate the waste canisters from the concrete retainment and the access
42 gallery has been considered as a possible alternative by the French Radioactive Waste
43 Management Agency (ANDRA) in the Underground Research Laboratory (URL)
44 excavated at a depth of 445-490 m in Callovo-oxfordian (COx) claystone at Bure

1 (Eastern France, Lebon and Mouroux, 1999), The main advantages of this option are:
2 (i) recycling excavated COx claystone as sealing material reduces the negative
3 environmental impact; (ii) replacing commercial bentonite by excavated COx
4 claystone reduces financial costs; (iii) there is no problem of mineralogical and
5 physico-chemical incompatibility between the host rock and the backfilling/sealing
6 material.

7 It is expected that once the backfilling/sealing material is installed, pore water from
8 the host rock will infiltrate the compacted claystone, thereby causing it to expand and
9 develop swelling pressure under nearly constant volume conditions. This swelling
10 pressure should be high enough to ensure sealing efficiency. Also, the swelling
11 pressure of the hydrated compacted claystone should not exceed the in-situ principal
12 minor stress (about 7 MPa - after Wileveau et al., 2007) so as to ensure satisfactory
13 mechanical stability. It is therefore important to study in detail the swelling properties
14 of the compacted crushed claystone. Since the pre-compacted backfilling/sealing
15 blocks will be subjected to hydromechanical conditions once installed, the study of the
16 swelling behaviour must be conducted under different boundary conditions. In this
17 investigation, four methods, namely a constant-volume method carried out in a
18 specifically designed new cell, a swelling-reloading method, a zero-swell and an
19 adjusted constant-volume method were respectively employed to evaluate the
20 swelling pressure of highly compacted crushed COx claystone in the laboratory.
21 Different hydro mechanical boundary conditions were applied to the specimens to
22 simulate the possible in-situ confinement and wetting process. In addition, long-term
23 tests were carried out to study time effects (Delage et al. 2006). The microstructure
24 changes of the specimens before and after wetting were also analyzed by performing
25 mercury intrusion porosimetry (MIP) and scanning electron microscopy (SEM) tests.

26 **2. Material**

28 The Callovo-Oxfordian (COx) claystone from the Bure site considered here contains
29 40-45% clay minerals (illite–smectite interstratified minerals being the dominant clay
30 minerals), 30% carbonates and 25-30% quartz and feldspar. The in-situ water content
31 is 2.8-8.7 %, the wet unit mass is 2.32-2.61 Mg/m³ and the specific gravity is 2.70
32 (Fouché et al. 2004).

33 COx claystone blocks obtained during excavation were air-dried and crushed to
34 powder at an initial water content of 2.8%. The grain size distribution of the powder
35 determined by dry sieving is presented in Fig.1. In order to obtain a higher water
36 content, a quantity of powder was put in a hermetic chamber where the relative
37 humidity was maintained at 91.3% at a temperature of 20°C (corresponding to a
38 suction of 12.6 MPa) by allowing vapour circulation of saturated ZnSO₄.7H₂O
39 solution (Delage et al. 1998). Once equilibrium was reached, the powder water
40 content was found to be 6.4%.

41 **3. Experimental methods and test program**

43 To determine the soil swelling pressure in the laboratory, the COx powder was first
44 compacted statically to a dry unit mass of 2.0 Mg/cm³ in an oedometer cell. The

1 swelling pressure of the compacted CO_x sample was then measured using four
2 methods: constant-volume, swell-reload, zero-swell and adjusted constant-volume
3 method respectively. Details of each method are presented below and the test
4 program is summarized in Table 1.

5 6 *3.1. Constant-volume method*

7 Traditionally, constant volume tests are performed based on the strain-controlled
8 technique (Azam et al. 2000; Tripathy et al. 2004; Hoffmann et al. 2007). There are
9 two strain-controlled techniques for constant volume conditions. The first consists in
10 applying a small incremental load on the specimen in the oedometer cell and to
11 prevent, when the specimen is wetted, any vertical expansion by progressively loading
12 the sample. Once no more expansion is observed upon wetting, the final total load
13 applied is defined as the swelling pressure of the soil (Al-Mhaidib 1998; Al-Shamrani
14 and Dhowian 2003; Thompson et al. 2006; Villar and Lloret 2008). The second
15 method consists in preventing any vertical movement by using a rigid reaction frame
16 and in measuring the swelling pressure with a force transducer (Lloret et al. 2003;
17 Aiban 2006; Hoffmann et al. 2007; Tang et al. 2008). In reality, it is difficult to
18 maintain a strictly constant volume condition - the measured swelling pressure is
19 influenced by many factors. In the former strain-controlled technique, each
20 incremental load corresponds to a soil compression, giving rise to changes in soil
21 microstructure that affect the swelling pressure. The swelling pressure determined is
22 therefore very sensitive to the load increment and the loading rate. Moreover, in order
23 to bring the specimen back to its initial volume, it is necessary to overcome the
24 friction between soil specimen and oedometer ring; that results in over-estimation of
25 the swelling pressure. In the latter constant volume technique, Tang et al. (2008)
26 found that the “constant volume” condition depends significantly on the stiffness of
27 the load cell and of the whole device. The corresponding swelling pressure error can
28 reach 1-2 MPa. Pejon and Zuquette (2006) pointed out that very small changes in
29 specimen height (e.g. a strain of 0.5%) would lead to significant swelling pressure
30 changes (e.g. 45-60%). Thus, the measurement of swelling pressure by the methods
31 mentioned above should be regarded as indirect measurements only. Up to now,
32 owing to difficulties related to testing devices, data on direct measurement of the
33 swelling pressure under constant volume conditions are scarce. For this reason, a new
34 constant volume cell has been developed that allows the swelling pressure to be
35 measured without any strain adjustment and any effect of the stiffness of the testing
36 device.

37 38 *3.1.1. View of the cell*

39 A schematic view of the new constant volume cell developed is presented in Fig. 2.
40 The pressure sensor was used to measure the swelling pressure. It was fixed inside the
41 upper part of the cell and put into direct contact with the top surface of the specimen.
42 The cylindrical soil specimen (70 mm in diameter and 10 mm in height) was placed
43 inside the middle part of the cell. A porous stone was placed at the bottom and in
44 contact with the soil specimen. Two inlets in the lower part of the cell ensured the

1 circulation of liquid water or relative humidity-controlled vapour for suction control.
2 Two outlets ensured the flow of water/vapour from the top surface of the soil
3 specimen.

4 5 *3.1.2. Detail about the pressure sensor*

6 As mentioned above, most constant-volume tests use common compression load cells
7 for the measurement of soil swelling pressure (Imbert and Villar 2006; Pejon and
8 Zuquette 2006; Thompson et al. 2006). These load cells present significant drawback
9 related to the induced strain by the soil swelling, especially when highly expansive
10 soils are tested (Pejon and Zuquette 2006; Tang et al. 2008). This strain leads to a
11 significant underestimation of the measured swelling pressure.

12 In this study, a BER-A-58S pressure sensor was used in the constant volume cell
13 (Fig. 3a). The working pressure is 5 MPa; the diameter of the working surface is
14 73 mm. The main difference from a standard pressure sensor (Fig. 3b) is that a void
15 space filled with mercury was machined below the diaphragm. Mercury is used so as
16 to minimize the deformation under external pressure. In the case of a standard
17 pressure sensor (Fig. 3b), obviously, much larger diaphragm deformation can be
18 expected.

19 20 *3.1.3. Test procedure*

21 In the constant volume test, the air-dried CO_x powder was statically compacted in an
22 oedometer cell to a dry unit mass of 2.0 Mg/cm³ (70 mm in diameter and a 10 mm in
23 height). After compaction, the soil specimen was taken out of the oedometer cell and
24 introduced into the constant volume cell. The three parts of the cell (top, middle and
25 bottom) were then mounted together using screws (Fig. 2).

26 The experimental setup is shown in Fig. 4. A pump was used to ensure the relative
27 humidity-controlled vapour circulation at the bottom of soil specimen for suction
28 control. During the test, changes in vertical stress were recorded automatically by a
29 data logging system. Room temperature was maintained at 20 ± 0.5 °C.

30 Five specimens were compacted and subjected to different suctions ($s = 57, 38, 9$
31 and 0 MPa, see also Table 1) by using the vapour equilibrium technique (Tang and
32 Cui 2005). To apply zero suction, distilled water was injected under a constant
33 pressure of 15 kPa from the bottom inlet of the cell to saturate the specimen. The
34 hydration path for each test was chosen as follows.

35 In test T1, an initial suction of 57 MPa was first applied, followed by 38 MPa,
36 9 MPa and 0 MPa suctions. Note that to study possible aging effects in the swelling
37 behaviour, the changes in swelling pressure at 0 MPa suction were monitored for
38 more than one year.

39 Test T2 was intended to evaluate the repeatability of the employed technique. After
40 stabilization of the swelling pressure under an initial suction of 57 MPa, a subsequent
41 wetting at 38 MPa suction was conducted.

42 In test T3, an initial suction of 38 MPa was applied, followed by a full saturation
43 using distilled water.

1 In test T4, a 9 MPa initial suction was applied. When equilibrium was reached, zero
2 suction was imposed by using distilled water. In test T5, the soil specimen was
3 directly wetted using distilled water.

4 5 *3.2. Swell-reload method*

6 Test T6 was performed according to the swelling-reloading method (Table 1). The
7 air-dried CO_x powder was statically compacted to a dry unit mass of 2.0 Mg/cm³ in
8 an oedometer cell (diameter 38 mm, height 10 mm). After compaction, the oedometer
9 cell was placed on a high-pressure oedometer frame (see Marcial et al. 2002 for more
10 detail) and the specimen was allowed to swell freely until stabilization under a
11 constant vertical stress of 0.1 MPa. It was then loaded in steps (24 hour interval
12 between each step) to bring the void ratio back to the initial value. The corresponding
13 vertical stress is the swelling pressure.

14 15 *3.3. Zero-swell method*

16 As in test T6, the soil specimen was compacted at a dry unit mass of 2.0 Mg/cm³ in
17 the oedometer cell (Test T7). It was then wetted on a high-pressure oedometer frame
18 under a vertical stress of 0.1 MPa using distilled water. Once the specimen started to
19 swell, the vertical load was increased so as to prevent any vertical swelling. During
20 this process, the maximum swell allowed was 20 μm - corresponding to a vertical
21 strain of 0.1%). Once the swelling was complete, the total applied load was recorded
22 and defined as the swelling pressure of the soil. Note that this method has been widely
23 employed internationally in determining the soil swelling pressure (Al-Mhaidib 1998;
24 Al-Shamrani and Dhowian 2003).

25 26 *3.4. Adjusted constant-volume method*

27 A triaxial press (Fig. 5) was used to apply the adjusted constant-volume method. The
28 experimental set-up is mainly composed of a piston, a load cell and an oedometer cell
29 mounted on an adjustable steel loading frame. The pressure applied to the specimen
30 was controlled by adjusting the level of the displacement shaft. The air-dried CO_x
31 powder was statically compacted to a dry unit mass of 2.0 Mg/cm³ and unloaded to
32 different axial stress levels. At a given initial stress level, distilled water was injected
33 by using a volume/pressure controller that was connected to the oedometer. During
34 this process, the “constant-volume” condition was ensured by fixing the displacement
35 shaft and, if necessary, manually adjusting it according to the monitoring of the
36 displacement transducer (electronic digital micrometer). The resulted swelling
37 pressure was measured using a load cell of 5 kN capacity. Three tests were performed
38 following this method (T8, T9 and T10; Table 1). Tests T8 and T9 were performed on
39 air-dried specimens ($w=2.8\%$), test T10 on a wetted specimen ($w=6.4\%$). Note test T8
40 was replicated with two specimens (T8-1 and T8-2) wetted under an initial axial stress
41 of 0.5 MPa. T9 and T10 were wetted under a higher initial axial stress of 7 MPa.

42 43 *3.5. Microstructure investigation*

1 Microstructural changes of the specimens before and after wetting under constant
2 volume conditions were observed by performing MIP and SEM tests. Freeze-drying
3 technique was employed to dehydrate the soil samples with minimum disturbance (see
4 Delage et al., 2006 for more details). Two samples were tested: one at the
5 ‘as-compacted’ state and another after wetting under an initial axial stress of 0.5 MPa,
6 obtained from test T8-2.

8 **4. Results**

9 *4.1 Results from constant-volume tests*

10 The results from the constant-volume tests using the new constant-volume cell (Fig.
11 2) under controlled suction are presented in Fig. 6. It can be seen during the
12 progressive wetting by applying successively the suctions of 57, 39, 9 and 0 MPa (test
13 T1, Fig. 6a), the swelling pressure increased to 0.17, 0.30, 0.81 and 1 MPa,
14 respectively. Note that the time needed to reach the equilibrium was about 15 days at
15 $s = 57$ MPa, 22 days at $s = 39$ MPa and 30 days at $s = 9$ MPa.

16 The results of tests T1 and T2 wetted under the same suctions (57 and 39 MPa) are
17 presented in Fig 6b. The two curves are quite similar, indicating a good repeatability
18 of the test and validating the test procedure.

19 The results from tests T3 and T4 are presented in Fig. 6c. In test T3, at 39 MPa
20 suction, the swelling pressure is about 0.24 MPa. At saturation, the swelling pressure
21 increased up to 1 MPa. In test T4, the swelling pressure measured by wetting directly
22 at 9 MPa suction is about 0.54 MPa. It is interesting to note that when zero suction
23 was applied, the same swelling pressure (1 MPa) was obtained as in test T3.

24 Fig. 6d shows the swelling pressure changes when directly hydrating under zero
25 suction (test T5). A final value of 0.82 MPa was measured.

26 Note that in tests T1 to T5, when zero suction was applied by injecting distilled
27 water, the swelling pressure increased quickly to a peak value followed by a slight
28 decrease and reached finally a plateau of stabilization. This phenomenon was not
29 observed under controlled-suction conditions.

30 Table 2 summarizes the swelling pressures of some typical bentonite-based
31 backfilling materials after saturation at different dry densities. The values were also
32 determined by the “constant-volume” method. It should be noted that the
33 “constant-volume” was not performed in a constant volume cell as developed in the
34 present investigation, but following the traditional procedure described previously. As
35 expected, the swelling pressures (Table 2) are generally much higher than those of
36 crushed COx arigillite (0.8-1.1 MPa, Fig. 6), even though the dry densities of these
37 bentonite-based backfilling materials are lower than 2.0 Mg/m^3 of crushed COx
38 arigillite. This can be explained by the high smectite fraction in bentonite-based
39 backfilling materials.

41 *4.2. Results from swell-reload and zero-swell tests*

42 Fig. 7 shows the results from the swelling-reloading test (T6) and the zero-swell test
43 (T7). Under a low vertical stress of 0.1 MPa, a quick free swell occurred in test T6,
44 stabilizing at 6.8% after a 98-hour period of saturation (see Fig. 7a). Additional

1 loadings induced a progressive compression of the soil specimen as shown by the
2 stress-strain curve shown in Fig. 7b. It can be seen that a stress of about 2.2 MPa was
3 required to bring the specimen back to its initial void ratio. This value is a measure of
4 the swelling pressure. It is seen to be much higher than the value determined from the
5 constant-volume test (0.82 MPa, T5).

6 The curve showing vertical strain changes of the zero-swell test (T7) is clearly
7 divided into two parts, one with a constant value equal to zero and the other with
8 increase in vertical strain (Fig. 7a). Deeper examination shows that the first part does
9 not correspond strictly to a zero value. A variation of less than 0.1% was recorded that
10 was the maximum value allowed during the test. Fig. 7b shows that the maximum
11 stress applied to maintain the constant volume is about 1 MPa, further loading
12 resulting in sample compression. The value of 1 MPa is by definition the swelling
13 pressure determined by the zero-swell test (T7). Comparison between the two
14 compression curves at high stresses (vertical stress higher than 4 MPa) shows that the
15 behaviour in tests T6 and T7 is the same (Fig. 7b).

16 4.3. Results from adjusted constant-volume test

17 Fig. 8 shows the changes in vertical stress and in void ratio in tests T8-1, T8-2, T9 and
18 T10. In test T8-1, the specimen was wetted under a low initial vertical stress of
19 0.5 MPa. A large change in void ratio was observed (e increased from 0.358 to 0.394
20 after 60 h, corresponding to a volumetric strain of 2.65%, Fig 8a). Only a slight
21 increase in vertical stress σ_v was observed during this period, from 0.67 to 0.87 MPa.
22 The “constant-volume” conditions were then adjusted by moving the displacement
23 shaft and reducing e as a consequence to its initial value. At equilibrium, e was equal
24 to 0.352 and σ_v to 3.5 MPa. The large change in void ratio observed can be explained
25 by the existence of a possible small gap between the piston and the load cell (**Erreur !**
26 **Source du renvoi introuvable.**5) that could not be avoided under low stress. A
27 similar procedure was applied in test T8-2 but with more care paid to the system
28 before flooding in order to minimise any similar gap. The results obtained show a
29 slight change in void ratio corresponding to a volumetric strain lower than 0.15% (Fig.
30 8 a). By contrast, σ_v increased quickly and stabilized at a value of 4.2 MPa after 70
31 hours. Note that the values of swelling pressure identified in tests T8-1 and T8-2 are
32 about twice that obtained by the swelling-reloading method (T6) and four times that
33 obtained by the constant-volume method (T5) and zero-swell method (T7).

34 In tests T9 (Fig. 8b) and T10 (Fig. 8c), the soil specimens were wetted under the
35 same initial high vertical stress of 7.0 MPa from different initial water contents (T9,
36 $w = 2.8\%$; T10, $w = 6.4\%$). The evolution of the vertical stress σ_v with hydration time
37 is similar: σ_v decreases first and tends to stabilization. In test T9, σ_v stabilized at
38 5.3 MPa, a slightly higher value than that of test T10 (3.8 MPa). During the whole
39 hydration period, e remained almost constant in both tests T9 and T10 (Fig. 8b and
40 Fig.8c respectively), indicating that the “constant volume” conditions were
41 satisfactory ensured.

42 4.4. Microstructure observation

1 For further analysis of hydration and swelling behaviour, microstructure changes
2 before and after wetting were investigated based on the SEM and MIP tests. Two
3 specimens were studied: an as-compacted specimen at $\rho_d = 2.0 \text{ Mg/m}^3$, and a
4 specimen from test T8-2 (after wetting under an initial vertical stress of 0.5 MPa in
5 constrained-volume condition). The results are shown in Figs. 9 and 10. In the
6 as-compacted specimen (Fig. 9a), large aggregates can be clearly observed, together
7 with large inter-aggregate pores of several micrometers in diameter. By contrast, for
8 the specimen wetted under constrained-volume condition, a quite different overall
9 image is observed (Fig. 9b). Indeed, although the dry unit mass is the same
10 (2.0 Mg/m^3), aggregates are no longer evident and the picture is characterized by a
11 general swell of the hydrated clay particles, rendering the global microstructure more
12 homogeneous. Moreover, the large pores observed in the as-compacted specimen
13 disappeared. Most inter-aggregate pores are less than $3 \mu\text{m}$ in diameter. This is
14 obviously the consequence of (i) swelling of clay particles, (ii) sub-division of
15 aggregates and (iii) the filling of inter-aggregate pores (Ye et al. 2009).

16 The pore size distribution curves exhibit a typical bimodal porosity in both
17 specimens (Fig. 10a). This phenomenon is consistent with other works carried out on
18 compacted soils (Ahmed et al. 1974, Delage et al. 1996, Delage et al., 2007; Tarantino
19 and De Col, 2008). Comparison between the curves of the two specimens shows that
20 wetting decreases the modal size of inter-aggregate pores from 2.1 to $0.5 \mu\text{m}$, in
21 agreement with the SEM observation (Fig. 9). Changes in intra-aggregate pores (< 0.1
22 μm diameter) are found to be insignificant. This is probably due to the
23 constrained-volume condition. The variations of intruded mercury void ratio (ratio of
24 intruded mercury volume with respect to solid volume) are evidence of the same
25 phenomenon (Fig. 10b). During wetting, the population of inter-aggregate pores of the
26 as-compacted sample defined by the inflection point on the curve at $2.1 \mu\text{m}$ was
27 displaced leftwards with an inter-aggregate pore population of inter-aggregate pores
28 defined by an inflection point at $0.5 \mu\text{m}$.

30 **5. Discussions**

31 *5.1. Effect of suction and hydration path*

32 Saiyouri et al. (1998, 2000, 2004) studied two compacted smectites (FoCa and MX80)
33 and suggested, following Mooney et al. (1952) and others, that the hydration of clay
34 minerals was governed by the discrete and progressive placement of water molecule
35 layers along the clay sheets within the clay particle. The number of water molecule
36 layers varies from zero in the dry state to four in the fully hydrated state. As
37 described also in Delage (2007), the swelling behaviour of bentonites is related to two
38 combined processes: i) the progressive absorption of successive layers of water
39 molecules in the interlayer spaces inside the particles enlarges the interlayer distance;
40 ii) the sub-division of particles into thinner ones leads to larger inter-particles pores
41 inside the aggregates. Chipera et al. (1997) and Likos (2004) also found that the
42 absorbed water layers in the interlayer space increase with ambient relative humidity
43 RH increase. In this investigation, specimens T1 to T5 were wetted by decreasing
44 suction in the constant-volume cell. The expansion of soil volume was constrained

1 and the swelling behaviour hence resulted in an increase in swelling pressure.
2 According to the results shown in Fig. 6, the stabilized swelling pressure is a function
3 of the levels of applied suction: the lower the suction the higher the swelling pressure.
4 This is mainly because the decrease of suction gives rise to an increase in absorbed
5 water layers along clay sheets and a decrease in the number of stacked clay sheets.
6 When suction was decreased from 57 to 9 MPa, the corresponding RH was increased
7 from 66 to 93.7 % at 20 °C temperature. According to Chipera et al. (1997), the
8 maximum absorbed water layer in the tested COx claystone may reach 2 layers.

9 Table 3 summarizes the swelling pressure values obtained in the different tests and
10 at different suctions. It is interesting to note that, whatever the suction value, the
11 measured swelling pressure in test T1 is always higher than that of T3, T4 and T5. In
12 addition, the values from tests T3 and T4 at zero suction are also higher than that from
13 test T5. These observations show that the swelling behaviour under the constant
14 volume condition is hydration path-dependent. A progressive hydration in steps from
15 a given suction value to lower ones would result in a higher swelling pressure when
16 compared to a direct hydration path to the final suction. A possible reason for this
17 could be that the soil hydration would be more homogenous when suction is
18 progressively decreased in steps.

19 The results presented in Fig. 6 show that the time needed for the swelling pressure
20 stabilization is also hydration path-dependent with a shorter time required to reach
21 stabilization with the direct path than with the step path. This behaviour may be due to
22 the distinct rates of water vapour migration that intervene within the soil according to
23 the wetting paths followed. The rate of water vapour migration is governed by the
24 suction gradient between the soil specimen and the bottom of the cell where the
25 suction was imposed; it increases with increasing suction gradient (Push 1982). When
26 the compacted air-dried COx claystone specimens (initial suction estimated at 100
27 MPa according to the ambient relative humidity comprised between 55 and 60% and
28 by neglecting any effect due to compaction or density changes) were gradually wetted
29 by increasing the relative humidity, water vapour was absorbed and moved inside the
30 specimen under the suction gradients. Normally, water vapour was firstly absorbed in
31 small inter-particle or inter-clay sheets pores where the suction potential was
32 relatively high. But when wetting continued, more and more water was absorbed by
33 soil specimen, the corresponding suction gradient gradually decreased and finally
34 reached equilibrium. During this process, the rate of vapour migration also decreased
35 progressively to zero. For test T1, the specimen was wetted in steps, the suction
36 gradient in each step was much lower than that in the case of direct path as tests T3
37 and T4 and the corresponding water vapour migration rate in test T1 was therefore
38 slower than that in tests T3 and T4.

39 The different swelling behaviours observed before and after water flooding in Fig.
40 6 may be attributed to the different hydration process involved in vapour-wetting and
41 **in** liquid-wetting. In the hydration process of vapour-wetting described above, the
42 water vapour was initially absorbed in intra-aggregate pores. By contrast, during
43 water-wetting, water firstly entered in the inter-aggregate pores. As a result,
44 aggregates begun to expand and sub-divide, leading to a sudden increase in swelling

1 pressure. Meanwhile, the wetting process weakened the aggregates mechanically,
2 resulting in the deformation and rearrangement of the aggregates. This explains the
3 drop of the measured swelling pressure. The SEM and MIP results shown in Figs. 9
4 and 10 confirm this explanation: the size of inter-aggregate pores decreased and the
5 soil microstructure became more homogenous after hydration.

6 Unlike the evolution pattern identified in this study for the swelling pressure, the
7 results obtained by Push (1982), Komine and Ogata (1994) and Imbert and Villar
8 (2006), show a pattern in which the swelling pressure first increases quickly up to a
9 peak, then decreases towards a minimum to increase again and finally reach a
10 constant value . This difference may be due to the different mineral compositions of
11 the soils tested. In the tests of Push (1982), Komine and Ogata (1994) and Imbert and
12 Villar (2006), bentonite or bentonite mixtures containing high proportions of
13 montmorillonite were used. In such materials, the swelling behaviour due to hydration
14 finally prevails over the collapse of the inter-aggregates pores, leading to a swelling
15 pressure increase after a short-term decrease. For the COx claystone tested here
16 illite–smectite interstratified mineral was the dominant clay mineral. As hydration
17 proceeds, the further swelling of clay particles is apparently not strong enough to
18 compensate for the fabric collapse and does not result in a second increase in swelling
19 pressure. This also explains the constant decrease of swelling pressure with hydration
20 time after the peak (Fig. 6).

21 22 *5.2. Effect of the test method*

23 The experimental results obtained in this study clearly show that swelling pressure
24 measurements are strongly test dependent. The swelling-reloading method gave
25 higher values than the constant-volume method and the zero-swell method. This is
26 consistent with observations made by other researchers. For instance, Tisot and
27 Aboushook (1983) and Thompson et al. (2006) reported that the swelling pressure
28 measured by the zero-swell method was about 1/3 of that by the swelling-reloading
29 method. Results reported by Al-Shamrani and Dhowian (2003) also indicated that the
30 swelling pressure measured by the swelling-reloading method was higher than that
31 obtained with the zero-swell method. The reason is that, in the swelling-reloading
32 method (T6), the specimen was allowed to swell by absorbing water under a relative
33 low load of 0.1 MPa. In constant-volume (T1 to T5) and zero-swell method (T7), the
34 specimens were not allowed to swell, so that hydration of clay particles was therefore
35 constrained. In the former case, an overall hydration can occur, giving rise to a high
36 swelling pressure value. By contrast, in the latter case, hydration could be more
37 heterogeneous, resulting in a lower swelling pressure. In addition, the difference in the
38 observed swelling pressures can be also due to the structure modification occurring
39 during the free swell phase, as well as to the friction developed between specimen and
40 oedometer cell during the re-loading phase. Nagaraj et al. (2009) attributed the
41 variations of the measured swelling pressure to the heterogeneous moisture
42 distribution over the thickness of the specimen. By introducing several vertical sand
43 drains in the specimen, they found that the differences in the swelling pressure by the
44 swelling-reloading method and the zero-swell method were reduced; both the swell

1 and swelling pressure of the tested specimens have been improved. They therefore
2 concluded that the measured swelling pressure value through a one-dimensional
3 oedometer test may not be an intrinsic property of the soil. Since the results from tests
4 T6 and T7 shown in Fig. 7 are similar during the compression in saturated state, this
5 suggests that the effect of swelling on the later compression is not significant.

6 When comparing the results of the constant-volume method (Fig. 6) and the
7 zero-swell method (T7 in Fig. 7 b), it is observed that the measured swelling pressures
8 are close, about 1 MPa. The swelling pressure measured by the constant-volume cell
9 developed by the authors is therefore consistent with the value obtained by the
10 standard method, confirming the validity of the developed constant-volume cell for
11 swelling pressure measurement.

12 When comparing the results from tests T6 (swell-reload method, Fig. 7) and T8
13 (adjusted constant-volume method, Fig. 8a), it is observed that the swelling pressure
14 from test T8 is higher than that from test T6. Actually, the main difference between
15 test T6 and test T8 is the loading procedure. In test T6, loading was performed after
16 the specimen was hydrated completely with the clay particles mechanically much
17 weakened. Nevertheless, in test T8, loading was performed during wetting where the
18 specimen was not saturated. Therefore, higher compaction energy should be applied
19 to overcome the specimen skeleton strength. In addition, the higher swelling pressure
20 obtained by the adjusted constant-volume tests can be also linked to the rapid loading
21 generated during wetting. The time was therefore insufficient for water drainage or
22 redistribution.

23 24 *5.3. Effect of the initial vertical loading*

25 Results shown in Fig. 8 indicate that the swelling behaviour of compacted crushed
26 COx claystone depends on the initial applied vertical stress. Indeed, wetting induced
27 an increase of σ_v when the initial vertical stress was low (0.5 MPa, Fig. 8a) and a
28 decrease of σ_v when the initial vertical stress was high (7 MPa, Figs. 8b, c). The
29 changes in swelling pressure of compacted expansive soils upon wetting were also
30 studied by Komine and Ogata (1999) and Lloret et al. (2003) with similar conclusions.
31 The observed phenomenon can be explained based on the double-structure model
32 described by Gens and Alonso (1992), Alonso et al. (1999), Sanchez et al. (2005) and
33 Tang and Cui (2009). On one hand, wetting increases the interlayer distance between
34 clay sheets, resulting in clay aggregates swelling. On the other hand, this weakens the
35 resistance of the macrostructure. When the soil is wetted in a constant volume
36 condition under low initial stress, the first mechanism prevails over the second and an
37 increase in swelling pressure is observed. On the contrary, when the soil is wetted
38 under a high initial stress, the second mechanism prevails: wetting induces collapse of
39 macro-pores and thus decreases the swelling pressure. To some extent, the
40 wetting-induced collapse of macro-pores was also evidenced by the MIP tests: the
41 results in Fig. 10b shows a decrease of the size of the macro-pores family after
42 wetting.

43 44 **Conclusion**

1 An experimental investigation on the swelling pressure of highly compacted crushed
2 COx claystone (initial dry unit mass $\rho_d = 2.0 \text{ Mg/m}^3$) under different boundary
3 conditions was conducted by four test methods. The microstructure of the material
4 before and after wetting was also studied using MIP and SEM techniques. The
5 following conclusions can be drawn:

- 6 (1) The swelling pressure of the tested COx claystone strongly depends on the test
7 method employed and varies from 1 to 5 MPa. The swelling behaviour was
8 found to be hydration path and hydration process dependent.
- 9 (2) The swelling pressure measured using the constant-volume cell developed by
10 the authors shows good agreement with that obtained by the conventional
11 standard zero-swell method. In addition, the cell is quite convenient to study the
12 long-term swelling behaviour of the soil since no load adjustment is necessary.
- 13 (3) Wetting under a volume-constrained condition decreased the size of the
14 dominant inter-aggregate pores, from 2.1 to 0.5 μm , while that of the
15 intra-aggregate pores space was not significantly influenced.

16 From a practical point of view, this investigation highlights that choosing an
17 appropriate swelling testing technique to simulate the field conditions is essential for
18 design. Moreover, when crushing the COx claystone, different procedures may be
19 used, producing powders with different grain size distribution. As a result, the
20 compressibility, swelling pressure and hydro-mechanical behaviour would be
21 different. This effect of grain size distribution needs to be investigated in detail in
22 order to define a specific protocol for the preparation of COx claystone powder that
23 can play an optimal role in repository.

24 **Acknowledgements**

25 The authors wish to acknowledge ANDRA (the French Radioactive Waste
26 Management Agency) for its financial support. The views expressed in this paper are
27 those of the authors and do not engage ANDRA in any matter.
28
29

30 **References**

- 31 Ahmed, S., Lovell, C.W., Diamond, S., 1974. Pore sizes and strength of compacted clay. ASCE
32 Journal of the Geotechnical Engineering Division 100, 407-425.
- 33 Al-Mhaidib, A.I., 1998. Swelling behaviour of expansive shales from the middle region of Saudi
34 Arabia. Geotechnical and Geological Engineering 16, 291-307.
- 35 Alonso, E.E., Vaunat, J., Gens, A., 1999. Modelling the mechanical behaviour of expansive clays.
36 Engineering Geology 54(1-2), 173-183.
- 37 Al-Shamrani, M.A., Dhowian, A.W., 2003. Experimental study of lateral restraint effects on the
38 potential heave of expansive soils. Engineering Geology 69, 63-81.
- 39 Aiban, S.A., 2006. Compressibility and swelling characteristics of Al-Khobar Palygorskite, eastern
40 Saudi Arabia. Engineering Geology 87, 205-219.
- 41 Azam, S., Abduljawwad, S.N., Al-Shayea, N.A., Al-Amoudi, O.S.B., 2000. Effects of calcium
42 sulphate on swelling potential of an expansive clay. Geotechnical Testing Journal 23, 389-403.

- 1 Chipera, S.J., Carey, J.W., Bish, D.L., 1997. Controlled-humidity XRD analyses: Application to
2 the study of smectite expansion/contraction. In *Advances in X-Ray Analysis*, Vol. 39, J.V.
3 Gilfrich et al., Eds., 713-721.
- 4 Delage, P., 2007. Microstructure features in the behaviour of engineered barriers for nuclear waste
5 disposal. In *Experimental Unsaturated Soils Mechanics*, Proc Int. Conf. on Mechanics of
6 Unsaturated Soils, 11-32, T. Schanz ed., Weimar, Germany, Springer.
- 7 Delage, P., Audiguier, M., Cui, Y.J., Howat, M.D., 1996. Microstructure of a compacted silt.
8 *Canadian Geotechnical Journal* 33 (1), 150-158.
- 9 Delage, P., Howat, M., Cui, Y.J., 1998. The relationship between suction and swelling properties
10 in a heavily compacted unsaturated clay. *Engineering Geology* 50 (1-2), 31-48.
- 11 Delage, P., Marcial, D., Cui, Y.J., Ruiz, X., 2006. Ageing effects in a compacted bentonite:
12 a microstructure approach. *Géotechnique* 56, 291-304.
- 13 Dueck, A., 2008. Laboratory results from hydro-mechanical tests on a water unsaturated bentonite.
14 *Engineering Geology*, 97: 15-24.
- 15 Fouché, O., Wright, H., Le Cléac'h, J.M., Pellenard, P., 2004. Fabric control on strain and rupture of
16 heterogeneous shale samples by using a non-conventional mechanical test. *Applied Clay Science*
17 26, 367-387.
- 18 Gens, A., Alonso, E.E., 1992. A framework for the behaviour of unsaturated expansive clays.
19 *Canadian Geotechnical Journal* 29, 1013-1032.
- 20 Nagaraj, H.B., Mohammed Munnas, M., Sridharan, A., 2009. Critical evaluation of determining
21 swelling pressure by swell-load method and constant volume method. *Geotechnical Testing*
22 *Journal* 32(4), 305-314.
- 23 Hoffmann, C., Alonso, E.E., Romero, E., 2007. Hydro-mechanical behaviour of bentonite pellet
24 mixtures. *Physics and Chemistry of the Earth* 32, 832-849.
- 25 Imbert, C., Villar, M.V., 2006. Hydro-mechanical response of a bentonite pellets/powder mixture
26 upon infiltration. *Applied Clay Science* 32, 197-209.
- 27 Komine, H., Ogata, N., 1994. Experimental study on swelling characteristics of compacted
28 bentonite. *Canadian Geotechnical Journal* 31, 478-490.
- 29 Landais, P., Aranyossy, J.F., 2007. Clays in natural & engineered barriers for radioactive waste
30 confinement. *Physics and Chemistry of the earth* 32, 1.
- 31 Lebon, P. Mouroux, B., 1999. Knowledge of the three French underground laboratory sites.
32 *Engineering Geology* 52(3-4), 251-256.
- 33 Likos, W., 2004. Measurement of crystalline swelling in expansive clay. *Geotechnical testing*
34 *Journal* 27, 1-7.
- 35 Lloret, A., Villar, M.V., Sanchez, M., Gens, A., Pintado, X., Alonso, E.E., 2003. Mechanical
36 behaviour of heavily compacted bentonite under high suction changes. *Géotechnique* 53(1),
37 27-40.
- 38 Marcial, D., Delage, P., Cui, Y.J., 2002. On the high stress compression of bentonites. *Canadian*
39 *Geotechnical Journal* 39 (4), 812-820.
- 40 Maugis P., Imbert, C., 2007. Confined wetting of FoCa clay powder/pellet mixtures:
41 Experimentation and numerical modeling. *Physics and Chemistry of the Earth*, 32, 795-808.
- 42 Mooney, R.W., Keenan, A.C., Wood, L.A., 1952. Adsorption of water vapour by montmorillonite.
43 II. Effect of exchangeable ions and lattice swelling as measured from X-ray diffraction. *J. Amer.*
44 *Chem. Soc.* 74, 1371-1374.

1 Pejon, O.J., Zuquette, L.V., 2006. Effects of strain on the swelling pressure of mudrocks.
2 International Journal of Rock Mechanics and Mining Sciences 43, 817-825.

3 Push, P., 1982. Mineral-water interactions and their influence on the physical behaviour of highly
4 compacted Na bentonite. Canadian Geotechnical Journal 19, 381-387.

5 Sanchez, M., Gens, A., Guimaraes, L.N., Olivella, S., 2005. A double structure generalized
6 plasticity model for expansive materials. International Journal for Numerical and Analytical
7 Methods in Geomechanics 29(8), 751-787.

8 Saiyouri, N., Hicher, P.Y., Tessier, D., 1998. Microstructural analysis of highly compacted clay
9 swelling. Proc. 2nd Int. Conf. on Unsaturated soils, Beijing: Academic publishers, Vol. 1,
10 119-124.

11 Saiyouri, N., Hicher, P.Y., Tessier, D., 2000. Microstructural approach and transfer water modeling
12 in highly compacted unsaturated swelling clays. Mech. Cohesive Frictional Mater 5, 41-60.

13 Saiyouri, N., Tessier, D., Hicher, P.Y., 2004. Experimental study of swelling in unsaturated
14 compacted clays. Clay Minerals 39, 469-479.

15 Tang, A. M., Cui, Y. J., 2005. Controlling suction by the vapour equilibrium technique at different
16 temperatures and its application in determining the water retention properties of MX80 clay. Can.
17 Geotech. J. 42 (1), 287-296.

18 Tang, A.M., Cui, Y.J., Barnel, N., 2008a. Thermo-mechanical behaviour of a compacted
19 unsaturated swelling clay. Géotechnique 58(1), 45-54.

20 Tang, A.M., Cui, Y.J., Le, T.T., 2008b. A study on the thermal conductivity of compacted
21 bentonites. Applied Clay Sciences 41, 181-189.

22 Tang, C.S., Tang, A.M., Cui, Y.J., Delage, P., Barnichon, J.D., Shi, B., 2008. On the
23 hydro-mechanical behaviour of a compacted crushed argillite. Proc. Int. Workshop on
24 Unsaturated Soils IWUS 08, Trento, in press.

25 Tang A.M., Cui Y.J. 2009. Modelling the thermo-mechanical behaviour of compacted expansive
26 clays. Géotechnique 59 (3), 185-195.

27 Tarantino, A., De Col, E., 2008. Compacted behaviour of clay. Géotechnique 58(3), 199-213.

28 Thompson, R.W., Perko, H.A., Rethamel, W.D., 2006. Comparison of constant volume swell
29 pressure and oedometer load-back pressure. Unsaturated Soils 2006, 1787-1798.

30 Tisot, J.P., Aboushook, M., 1983. Triaxial study of swelling characteristics. Proceedings in the 7th
31 Asian Regional Conference on Soil Mechanics and Foundation Engineering, Haifa, Vol. 1,
32 94-97.

33 Tripathy, S., Sridharan, A., Schanz, T., 2004. Swelling pressures of compacted bentonites from
34 diffuse double layer theory. Canadian Geotechnical Journal 41, 437-450.

35 Wileveau, Y., Cornet, F.H., Desroches, J. Blumling, P. 2007. Complete in situ stress determination
36 in an argillite sedimentary formation. Physics and Chemistry of the Earth 32(8-14), 866-878.

37 Villar, M.V., Lloret, A., 2008. Influence of dry density and water content on the swelling of a
38 compacted bentonite. Applied Clay Science 39, 38-49.

39 Ye W.M., Cui Y.J., Qian L.X., Chen B. 2009. An experimental study of the water transfer through
40 compacted GMZ bentonite. Engineering Geology 108, 169-176.

41 Ye, W.M., Chen, Y.G., Chen, B., Wang, Q., Wang, J., 2010, Advances on the knowledge of the
42 buffer/backfill properties of heavily-compacted GMZ bentonite, Eng. Geol. (2010),
43 doi:10.1016/j.enggeo.2010.06.002.

44

1 **List of Tables**

2

3 Table 1. Tests program

4 Table 2. The swelling pressures of some typical bentonite-based backfilling materials

5 Table 3. The swelling pressures at different suctions

6

7

8

9 **List of Figures**

10

11 Fig. 1. Grain size distribution of the crushed COx claystone powder

12 Fig. 2. Schematic view of the developed constant-volume cell

13 Fig. 3. Schematic view of the pressure sensors: (a) BER-A-58S pressure sensor; (b)
14 standard pressure sensor

15 Fig. 4. Schematic view of the experimental setup using the constant-volume cell

16 Fig. 5. Schematic view of the swelling test using a triaxial press

17 Fig. 6. Swelling pressure evolution during wetting at different suctions

18 Fig. 7. Results from the swell-reload and zero-swell tests; (a) changes in vertical swell
19 with time and (b) change in void ratio with applied vertical stress

20 Fig. 8. Results from the adjusted constant-volume test; (a) tests T8-1 and T8-2; (b)
21 test T9; (c) test T10.

22 Fig. 9. SEM pictures, (a) as-compacted specimen at a dry unit mass of 2.0 Mg/cm^3
23 and (b) specimen wetted under constrained-volume condition

24 Fig. 10. Pore size distribution curves of as-compacted and wetted specimens

25

26

Tables

Table 1. Tests program

Test method	Test No.	Initial water content/%	Apparatus	Specimen size/mm	Wetting condition
Constant-volume	T1	2.8	Fig. 4	H = 10, D = 70	Suction controlled: $s = 57, 38, 9,$ and 0 MPa
	T2	2.8	Fig. 4	H = 10, D = 70	Suction controlled: $s = 57$ and 38 MPa
	T3	2.8	Fig. 4	H = 10, D = 70	Suction controlled: $s = 38$ and 0 MPa
	T4	2.8	Fig. 4	H = 10, D = 70	Suction controlled: $s = 9$ and 0 MPa
	T5	2.8	Fig. 4	H = 10, D = 70	Suction controlled: $s = 0$ MPa
Swell-reload	T6	2.8	Fig. 5	H = 10, D = 38	Injecting distilled water
Zero-swell	T7	2.8	Fig. 5	H = 20, D = 50	Injecting distilled water
Adjusted constant-volume	T8-1	2.8	Fig. 6	H = 20, D = 50	Injecting distilled water
	T8-2				
	T9	2.8	Fig. 6	H = 20, D = 50	Injecting distilled water
	T10	6.4	Fig. 6	H = 20, D = 50	Injecting distilled water

Table 2. The swelling pressures of some typical bentonite-based backfilling materials

Materials	Methods	Dry unit mass, Mg/m ³	Swelling pressure, MPa	References
FoCa bentonite/pellet	Constant-volume	1.6	3.0-3.5	Maugis and Imbert (2007)
FEBEX bentonite/pellet	Constant-volume	1.5	2.3-3.0	Hoffmann et al. (2007)
FEBEX bentonite	Constant-volume	1.7	9.0-13.0	Villar and Lloret (2008)
MX80 bentonite	Constant-volume	1.6	5.1-5.8	Dueck (2008)
GMZ bentonite	Constant-volume	1.7	4.0-4.5	Ye et al. (2010)

Table 3. The swelling pressures at different suctions

Test No.	$s = 57$ MPa	$s = 39$ MPa	$s = 9$ MPa	$s = 0$ MPa
----------	--------------	--------------	-------------	-------------

T1	0.17 MPa	0.31 MPa	0.81 MPa	1.08 MPa
T2	0.17 MPa	0.33 MPa	/	/
T3	/	0.24 MPa	/	0.99 MPa
T4	/	/	0.54 MPa	0.97 MPa
T5	/	/	/	0.82 MPa

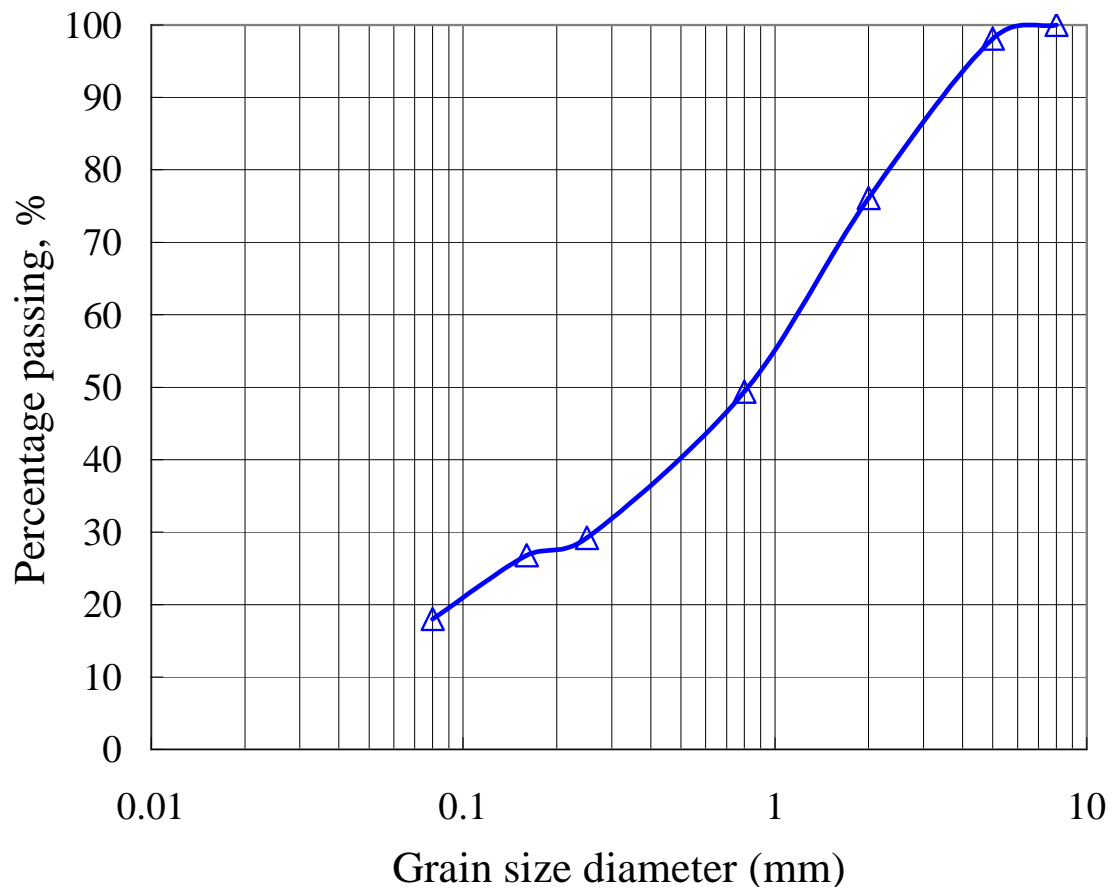

Fig. 1. Grain size distribution of the crushed COx claystone powder

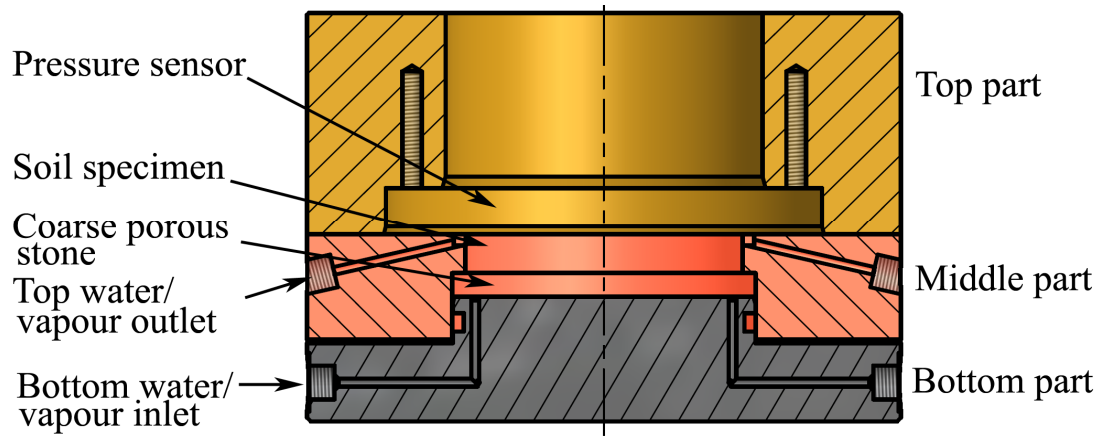

Fig. 2. Schematic view of the developed constant-volume cell

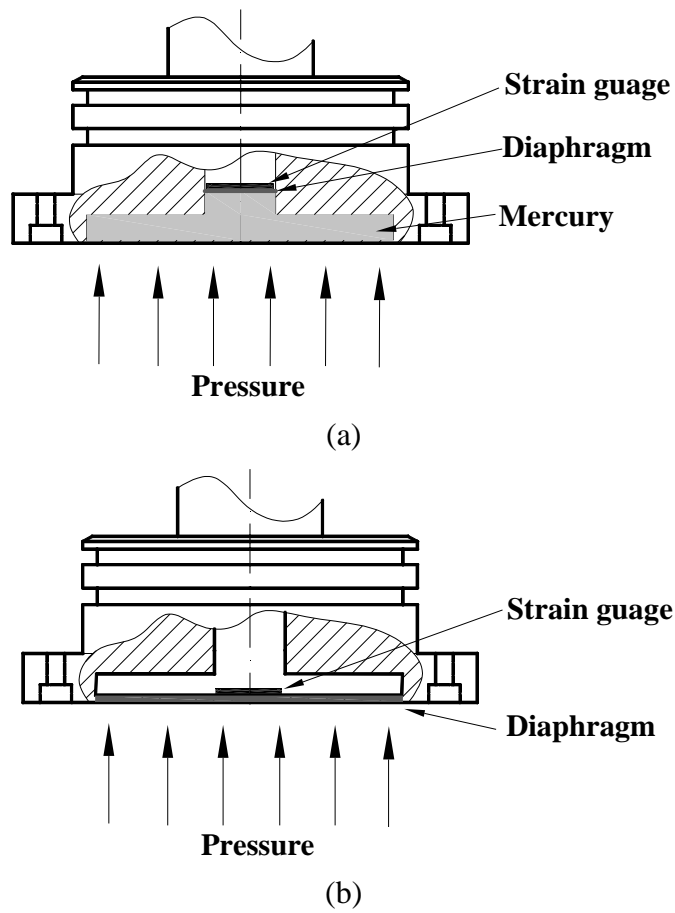

Fig. 3. Schematic view of the pressure sensors: (a) BER-A-58S pressure sensor; (b) standard pressure sensor

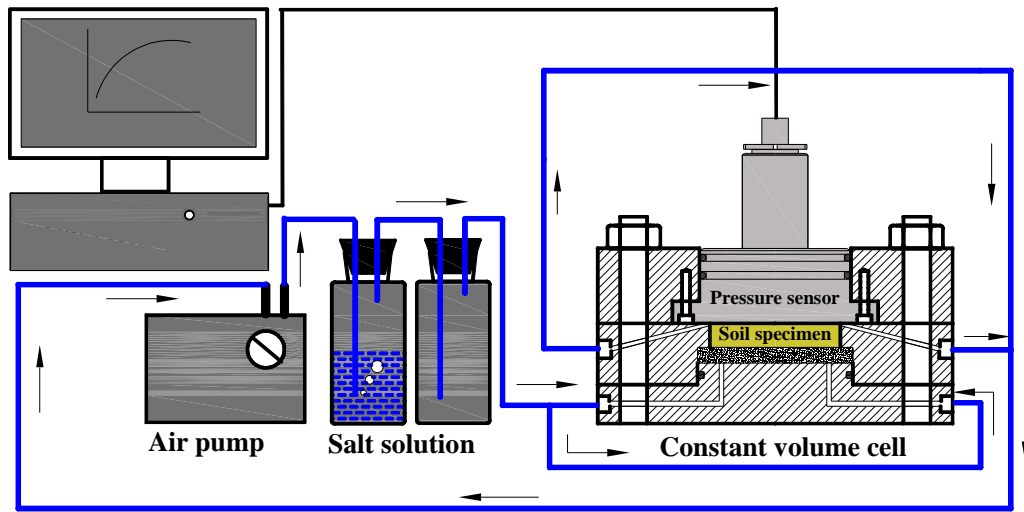

Fig. 4. Schematic view of the experimental setup using the constant-volume cell

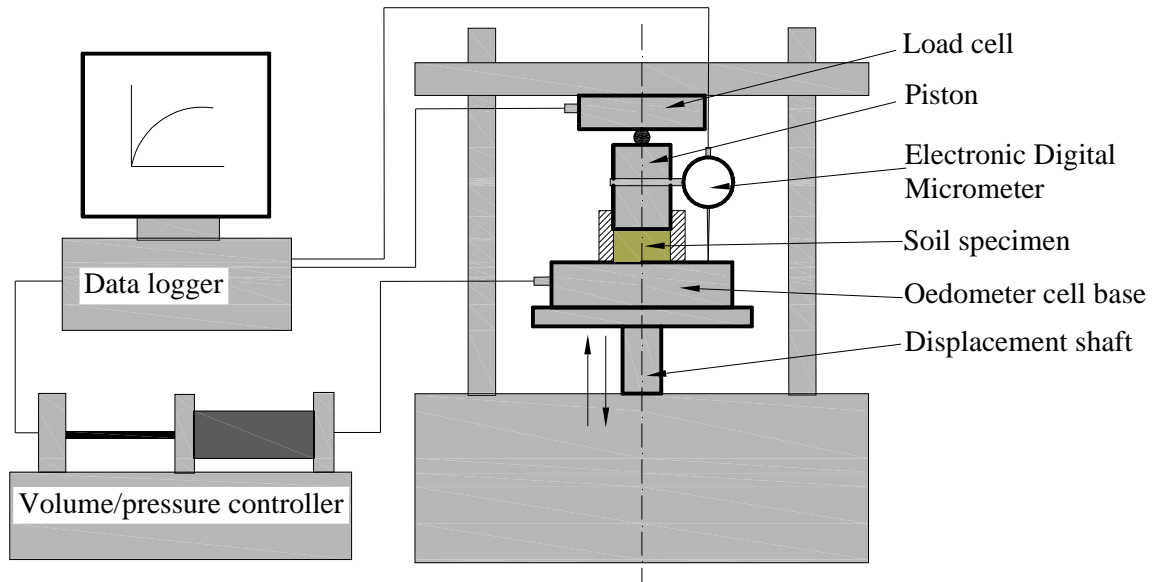
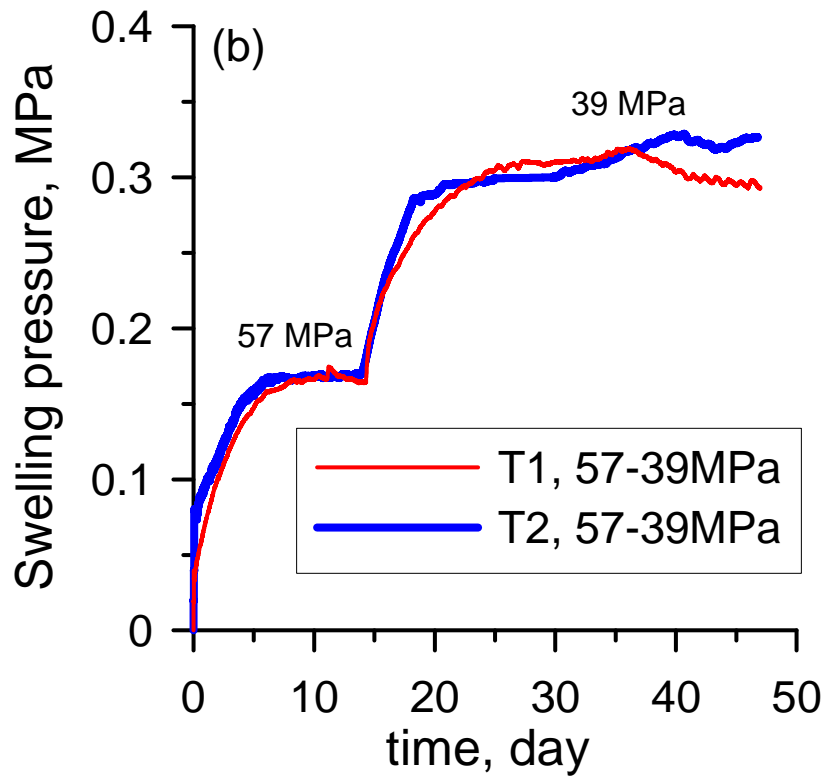
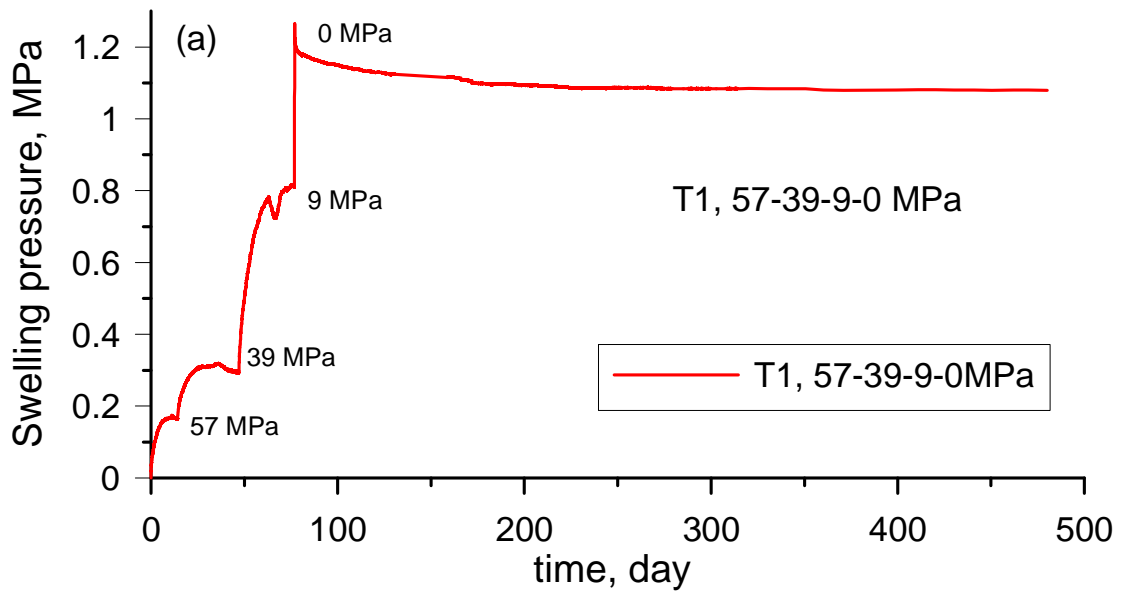

Fig. 5. Schematic view of the swelling test using a triaxial press



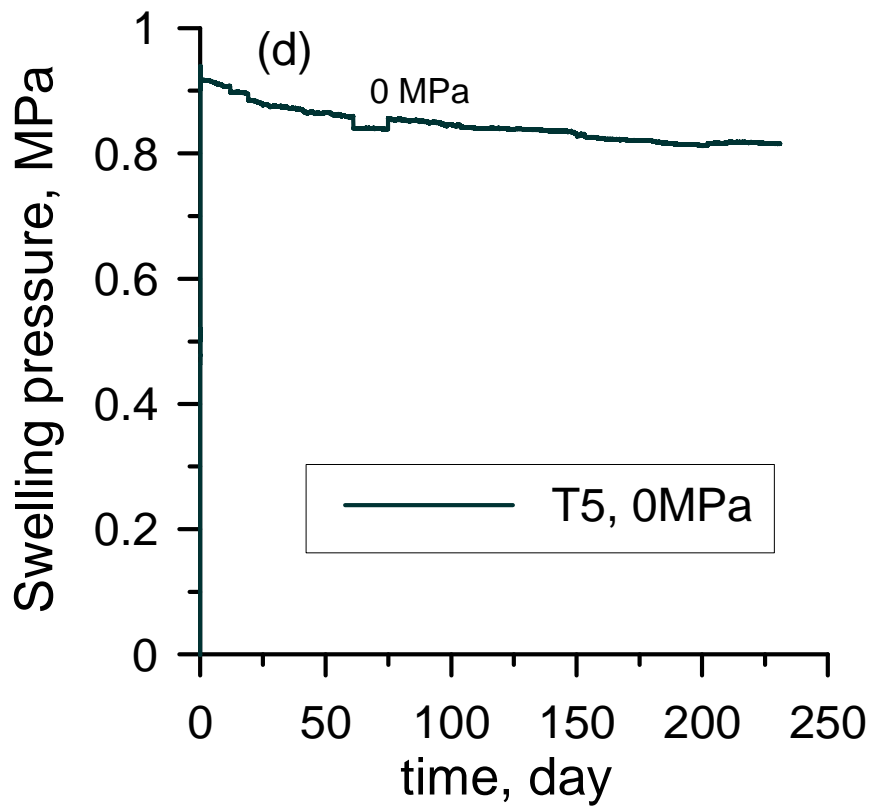
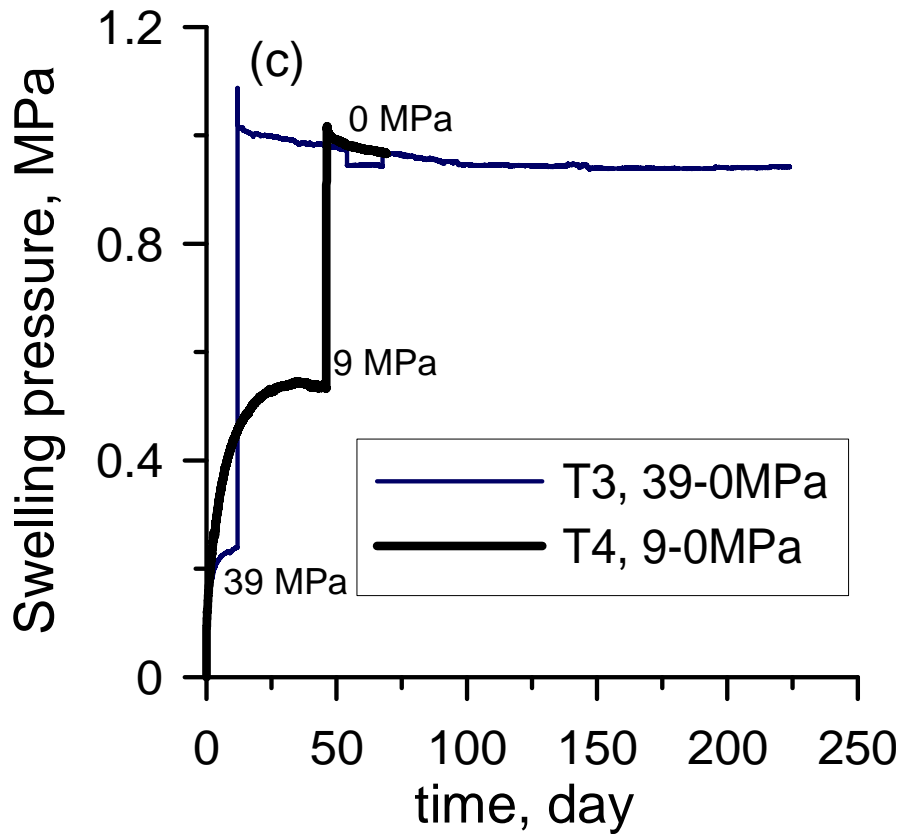

Fig. 6. Swelling pressure evolution during wetting at different suctions

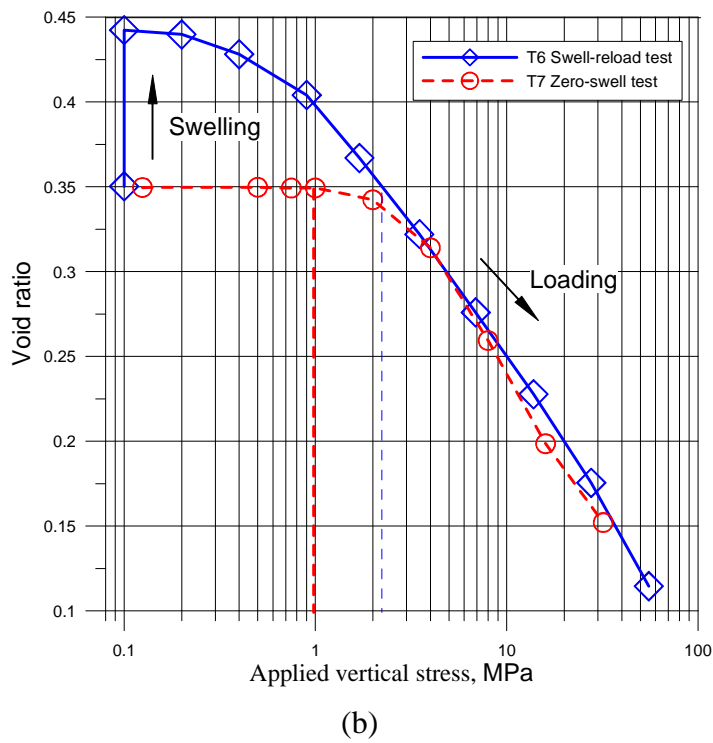
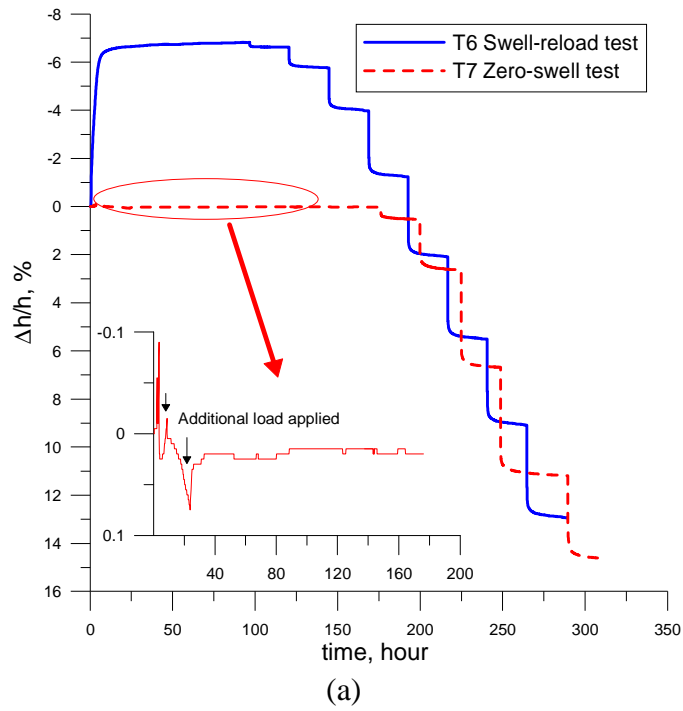

Fig. 7. Results from the swell-reload and zero-swell tests; (a) changes in vertical swell with time and (b) change in void ratio with applied vertical stress

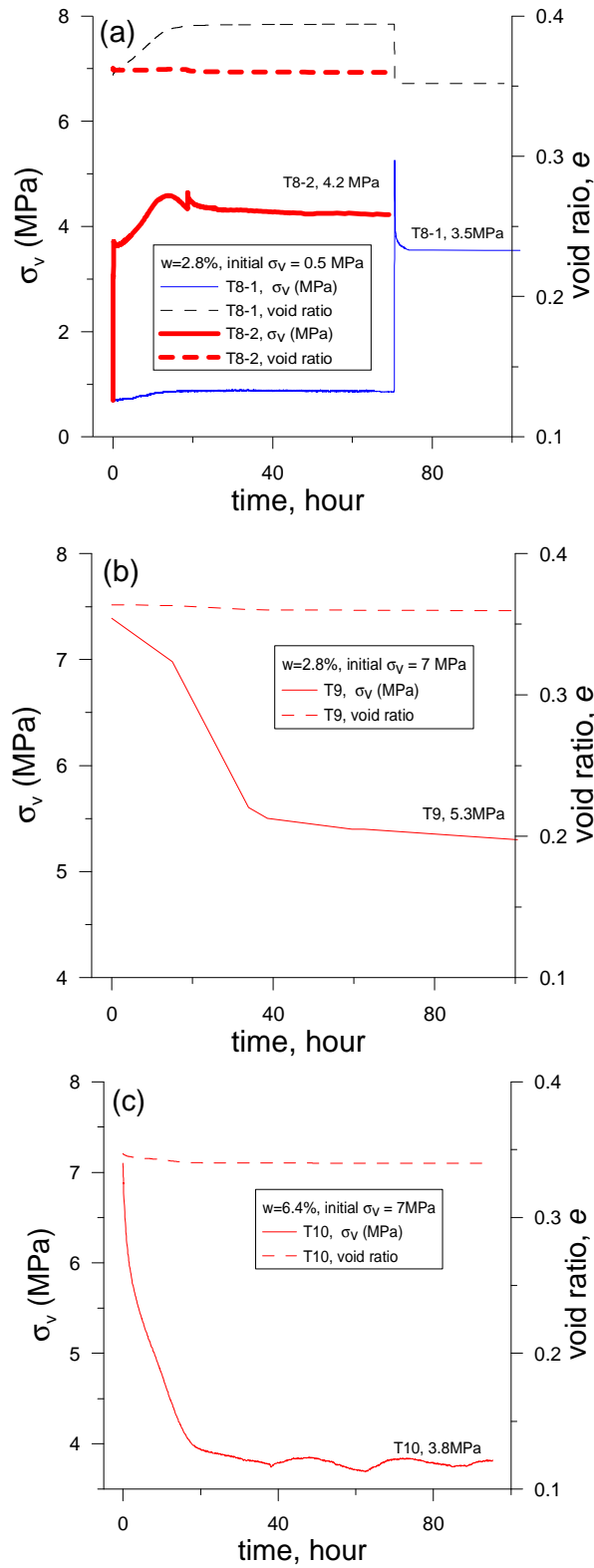

Fig. 8. Results from the adjusted constant-volume test; (a) tests T8-1 and T8-2; (b) test T9; (c) test T10.

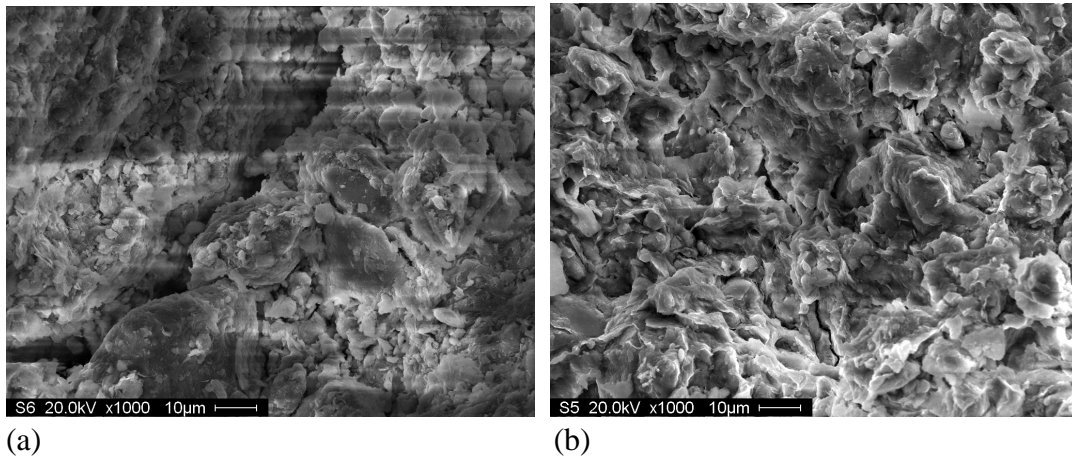
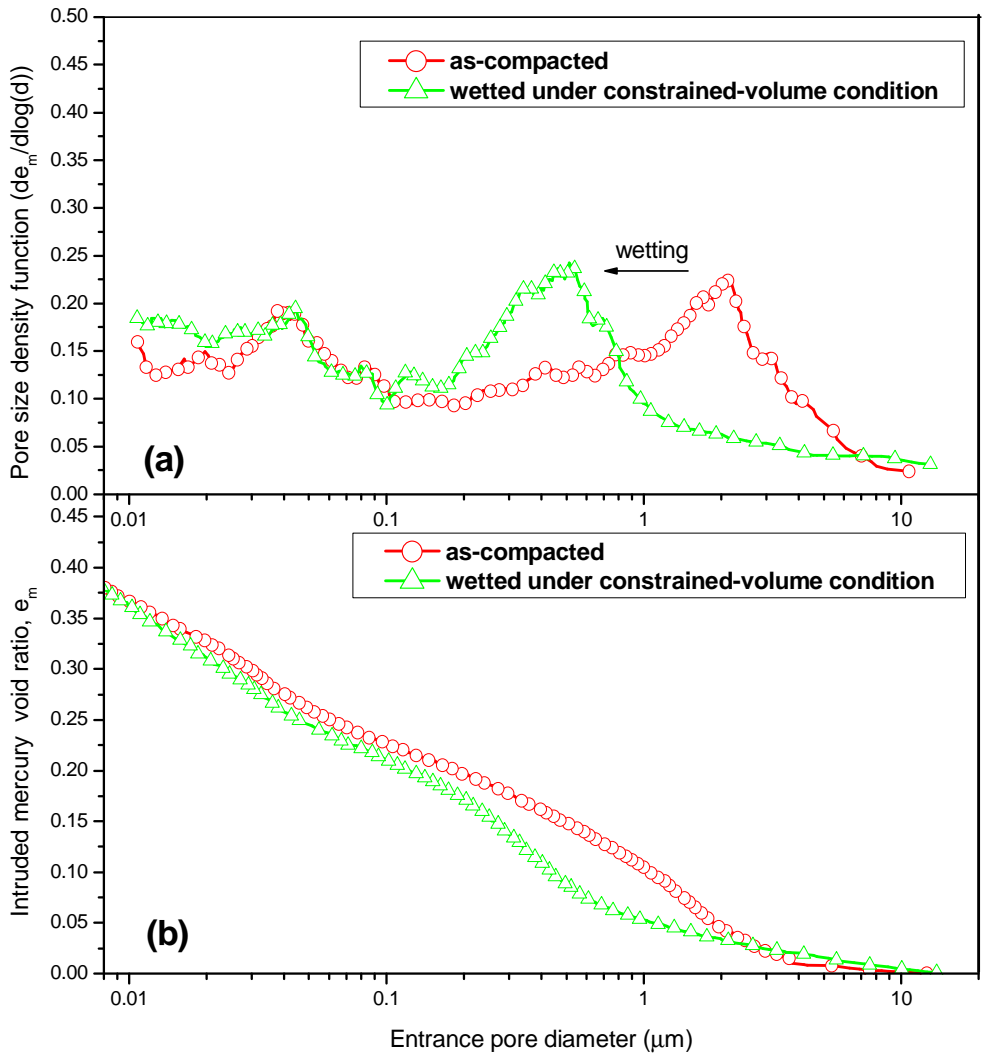

Fig. 9. SEM pictures, (a) as-compacted specimen at a dry unit mass of 2.0 Mg/cm^3 and (b) specimen wetted under constrained-volume condition

1
2



3
4

Fig. 10. Pore size distribution curves of as-compacted and wetted specimens