

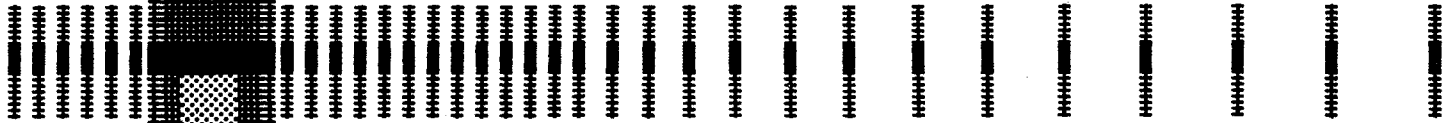

**NUMERICAL ESTIMATES OF POTENTIAL FOR
GROUNDWATER CONTAMINATION FROM LAND
BURIAL OF MUNICIPAL WASTES IN ILLINOIS**

Bruce R. Hensel, Richard C. Berg, and Robert A. Griffin



1990
ENVIRONMENTAL GEOLOGY 134
HWRIC RR 035

Department of Energy and Natural Resources
ILLINOIS STATE GEOLOGICAL SURVEY
HAZARDOUS WASTE RESEARCH AND INFORMATION CENTER

NUMERICAL ESTIMATES OF POTENTIAL FOR GROUNDWATER CONTAMINATION FROM LAND BURIAL OF MUNICIPAL WASTES IN ILLINOIS

Bruce R. Hensel, Richard C. Berg, and Robert A. Griffin

Illinois State Geological Survey

Final Report

Hazardous Waste Research and Information Center
Department of Energy and Natural Resources
Jacqueline Peden, Project Officer
ENR Contract No. HWR 87033

and

Illinois Pollution Control Board
Richard DiMambro and Harish Rao, Project Officers
Contract No. HBG2327

**1990
Environmental Geology 134
HWRIC RR 035**

Illinois State Geological Survey
615 East Peabody Drive
Champaign, Illinois 61820

Hazardous Waste Research and Information Center
One East Hazelwood Drive
Champaign, Illinois 61820

ACKNOWLEDGMENTS

The authors gratefully acknowledge the partial support of this project by the Illinois Pollution Control Board and IPCB Project Officers Richard DiMambro and Harish Rao, and the Illinois Hazardous Waste Research and Information Center and its project officer, Jacqueline Peden. The authors especially thank Thomas Prickett, T.A. Prickett and Associates, for his assistance with parts of this research.

The research programs of the Illinois Pollution Control Board (IPCB) and the Hazardous Waste Research and Information Center (HWRIC) funded this project through contract numbers HBG2327 and HWR87033. This report, part of HWRIC's Research Report Series, was subject to HWRIC's external peer review. It was also reviewed by the IPCB. Mention of trade names or commercial products does not constitute endorsement.

CONTENTS

ACKNOWLEDGMENTS	ii
TABLES	iii
FIGURES	iv
EXECUTIVE SUMMARY	vii
INTRODUCTION	1
Background	1
Project Objectives	1
Approach and Limitations	1
DESCRIPTION OF GEOLOGIC SEQUENCES	2
Background	2
Sequence Descriptions	2
METHODS OF STUDY	4
Approach	4
Numerical Models	5
Data Collection and Preparation	11
Major Assumptions	14
RESULTS	17
Hydrogeological Scenarios	17
Ranking of Hydrogeological Scenarios	40
SUMMARY AND CONCLUSIONS	45
REFERENCES	49
APPENDICES	51
Appendix A: Tabulated Raw Data from the PLASM/Random Walk Modeling	51
Appendix B: Plots	63

TABLES

1 Description and ranking value of hydrogeological scenarios	viii
2 Hydrogeological scenarios for which contaminants from a simulated landfill do not migrate past given compliance distances within 100 years	ix
3 Hydraulic conductivity (from Berg, Kempton, and Cartwright, 1984) and porosity (from Walton, 1985) values input to PLASM and Random Walk	12
4 Retardation factors input to Random Walk model	15
5 Summary of scenarios modeled for each geologic sequence	16
6 Maximum extent of contaminant migration for all scenarios, as calculated by PLASM/Random Walk model	17
7 Comparison of PLASM/Random Walk results to PLUME and MOC results for chloride, A1 scenario, 10-foot liner design	21
8 Comparison of PLASM/Random Walk results to PLUME and MOC results for chloride, A2 scenario, 10-foot liner design	23
9 Comparison of maximum contaminant concentrations 100 feet downgradient of the source area for the A2 and A2b scenarios	25
10 Comparison of PLASM/Random Walk results to PLUME and MOC results for chloride, A4 scenario, 10-foot liner design	27
11 Comparison of confining layer thickness for the 10-foot and 3-foot landfill liner designs of the C1, C2b, C4, and C5 scenarios	29
12 Comparison of PLASM/Random Walk results to PLUME and MOC results for chloride, C1 scenario, 10-foot liner design	31
13 Comparison of PLASM/Random Walk results to PLUME and MOC results for chloride, C2 scenario, 10-foot liner design	33
14 Comparison of PLASM/Random Walk results to PLUME and MOC results for chloride, C2b scenario, 10-foot liner design	33

15 Comparison of PLASM/Random Walk results to MOC results for chloride, C4 scenario, 10-foot liner design	35
16 Comparison of PLASM/Random Walk results to PLUME and MOC results for chloride, C5b scenario, 10-foot liner design	38
17 Comparison of PLASM/Random Walk results to PLUME and MOC results for chloride, D scenario, 10-foot liner design	38
18 Comparison of PLASM/Random Walk results to PLUME and MOC results for chloride, E scenario, 10-foot liner design	39
19 Comparison of PLASM/Random Walk results to PLUME and MOC results for chloride, F scenario, 10-foot liner design	39
20 Comparison of PLASM/Random Walk results to MOC results for chloride, G scenario, 10-foot liner design	40
21 Migration Ratings	42
22 Mobility and Combined Ratings	43
23 Rankings of the hydrogeological scenarios (10-foot landfill liner design) based on concentration of methylene chloride and trichloroethylene at the IPCB-proposed 100-foot compliance distance	45
24 Hydrogeological scenarios for which contaminants from a simulated landfill do not migrate past given compliance distances within 100 years	46

FIGURES

1 Diagrams of geologic sequences	xii
2 Plan (A) and cross-sectional (B) views of the grid used for PLASM/Random Walk simulations	8
3 Schematic cross sections of the 10-foot (A) and 3-foot (B) landfill liner designs	9
4 Sensitivity of PLASM/Random Walk simulations to length of time steps	10
5 Cross-sectional view of the grid used for the MOC simulations	11
6 Maximum extent of contaminant migration predicted for the A1 scenario by PLASM/Random Walk	18
7 Maximum concentrations of contaminants 100 feet from the source area of the A1 scenario predicted PLASM/Random Walk	18
8 Maximum extent of contaminant migration predicted for the A2 scenario by PLASM/Random Walk	20
9 Maximum concentrations of contaminants 100 feet from the source area of the A2 scenario predicted by PLASM/Random Walk	20
10 Maximum extent of contaminant migration predicted for the A2b scenario by PLASM/Random Walk	22
11 Maximum concentrations of contaminants 100 feet from the source area of the A2b scenario predicted by PLASM/Random Walk	22
12 Steady-state head distribution predicted for the A4 scenario by PLASM	24
13 Maximum extent of contaminant migration predicted for the A4 scenario by PLASM/Random Walk	24
14 Maximum extent of contaminant migration predicted for the A4b scenario by PLASM/Random Walk	26
15 Maximum concentrations of contaminants 100 feet from the landfill source area of the A4b scenario predicted by PLASM/Random Walk	26
16 Maximum extent of contaminant migration predicted for the B scenario by PLASM/Random Walk	28
17 Maximum concentrations of contaminants 100 feet from the landfill source area of the B scenario predicted by PLASM/Random Walk	28
18 Maximum extent of contaminant migration predicted for the C1 scenario by PLASM/Random Walk	30
19 Maximum concentrations of contaminants 100 feet from the landfill source area of the C1 scenario predicted by PLASM/Random Walk	30

20	Maximum extent of contaminant migration predicted for the C2 scenario by PLASM/Random Walk	32
21	Maximum concentrations of contaminants 100 feet from the landfill source area of the C2 scenario predicted by PLASM/Random Walk	32
22	Maximum extent of contaminant migration predicted for the C2b scenario by PLASM/Random Walk	34
23	Maximum concentrations of contaminants 100 feet from the landfill source area of the C2b scenario predicted by PLASM/Random Walk	34
24	Maximum extent of contaminant migration predicted for the C4 scenario by PLASM/Random Walk	36
25	Chloride plume in layer 3 (cemented sandstone aquifer) of the C4 scenario, as predicted by PLASM/Random Walk	36
26	Steady-state head distribution predicted for the C5 scenario by PLASM	37

EXECUTIVE SUMMARY

The Illinois Pollution Control Board (IPCB) has proposed new regulations to reduce the likelihood of groundwater contamination at waste disposal sites. The regulatory requirements would set new design and performance standards for solid, nonhazardous waste disposal facilities. One such performance standard is a compliance distance of 100 feet around all sanitary landfills. Applicants for new permits must demonstrate that the proposed waste disposal site will not cause degradation of groundwater beyond this compliance distance for a minimum of 100 years.

This report quantitatively assesses the potential for groundwater contamination from land burial of municipal wastes in hydrogeologic situations common to Illinois. These ratings can be used for preliminary, regional feasibility assessments of site suitability for land burial of municipal wastes. The research also evaluates the appropriateness of IPCB's proposed compliance distance of 100 feet surrounding a landfill as a regulatory requirement for maximum leachate migration during a 100-year period.

Sixteen hydrogeological scenarios were quantitatively ranked according to their potential for groundwater contamination. The conceptual models for these scenarios were based on geologic sequences in Illinois mapped by Berg, Kempton, and Cartwright (1984). The transport of six constituents [chloride, cadmium, chemical oxygen demand (COD), methylene chloride, trichloroethylene (TCE), and xylene] commonly found in municipal landfill leachate was mathematically simulated. Simulations for these 16 scenarios were performed using the Prickett Lonquist Aquifer Simulation Model (PLASM; Prickett and Lonquist, 1971) and the Random Walk contaminant transport model (Prickett, Naymik, and Lonquist, 1981). The six chemical constituents exhibit a broad range of characteristics, with mobilities ranging from conservative (nonadsorbed, nondegraded, i.e., constituents for which movement is coincidental with groundwater) to very low, and toxicities ranging from highly toxic to nontoxic. Two landfill designs were incorporated into the conceptual models: a 10-foot-thick bottom liner with leachate head 10 feet above the liner and a 3-foot-thick bottom liner with a leachate collection system. The leachate collection system was simulated by setting head in the landfill at 1 foot. A constant initial concentration for each contaminant was used in all scenarios. These procedures allowed comparison of contaminant migration rates for the hydrogeological scenarios without introducing a bias related to the landfill design or its initial contaminant concentrations.

The input parameters related to hydrogeologic and contaminant transport were obtained primarily from published sources. Some parameters, such as retardation factors, were calculated using common values cited in published sources. When a range of values was published for one parameter, the value that would cause the greatest migration or highest concentration was selected. Model predictions of contaminant migration were verified by comparing them with similar output from two different models.

Major assumptions pertaining to the hydrogeological scenarios and the hypothetical landfill used for the model were that:

- 1) water table was at the base of the landfill;
- 2) bottom of the landfill liner (trench) was 20 feet below ground surface;
- 3) no pumping wells or other man-caused effects, other than the landfill, would influence the groundwater flow system;
- 4) hydrogeologic parameters within specified geologic materials were constant;
- 5) fluid density and viscosity were independent of solute concentration;
- 6) decay and biodegradation of the modeled contaminants were negligible.

The assumptions used in this assessment were for a worst-case scenario of seepage through the liner (see page 14). This assessment may be used only for comparison of relative migration for hydrogeologic conditions that meet those assumptions. For example, the assumption of the water table at the base of the liner was used for scenarios with the 3-foot liner design. The more typical case in Illinois probably would be a water table above the bottom liner, in which case groundwater flow would be into the landfill and contaminant migration probably would be very limited.

Table 1 Description and ranking value of hydrogeologic scenarios.

Designation	Geologic description	Relative ranking	
A1	20 feet of sand overlying 30 feet of highly permeable, fractured limestone or dolomite ($K=10^{-3}$ cm/s)	(10)	1000
		(3)	1000
		(T)	1000
C1	35 feet of clayey diamicton overlying highly permeable, fractured limestone or dolomite ($K=10^{-3}$ cm/s)	(10)	396
		(3)	918
		(T)	657
A2b	50 feet of highly permeable unconsolidated sand ($K=10^{-3}$ cm/s)	(10)	492
		(3)	646
		(T)	569
A2	20 feet of clayey diamicton overlying 30 feet of unconsolidated sand ($K=10^{-3}$ cm/s)	(10)	485
		(3)	629
		(T)	557
C2b	35 feet of silty diamicton overlying 15 feet of unconsolidated sand ($K=10^{-3}$ cm/s)	(10)	335
		(3)	643
		(T)	489
C2	30 feet of clayey diamicton overlying a continuous sand lens 10 feet thick ($K=10^{-3}$ cm/s)	(10)	282
		(3)	528
		(T)	405
B	20 feet of unconsolidated sand ($K=10^{-3}$ cm/s) overlying clayey/diamicton or other material of low hydraulic conductivity	(10)	349
		(3)	-a-
		(T)	349
A4b	20 feet of clayey diamicton overlying 30 feet of moderately permeable sandstone ($K=10^{-4}$ cm/s)	(10)	70
		(3)	131
		(T)	100
A4	20 feet of clayey diamicton overlying 30 feet of cemented sandstone ($K=10^{-5}$ cm/s)	(10)	9.2
		(3)	9.7
		(T)	9.4
C4	35 feet of clayey diamicton overlying 15 feet of cemented sandstone ($K=10^{-5}$ cm/s)	(10)	1.8
		(3)	11.2
		(T)	6.5
C5b	35 feet of silt ($K=10^{-5}$ cm/s) overlying 15 feet of clayey diamicton	(10)	6.22
		(3)	0.42
		(T)	3.32
D	50 feet of sandy diamicton ($K=10^{-6}$ cm/s)	(10)	3.83
		(3)	2.36
		(T)	3.10
C5	50 feet of clayey diamicton with a discontinuous sand lens ($K=10^{-3}$ cm/s) 15 feet thick, 35 feet below ground surface	(10)	2.81
		(3)	-a-
		(T)	2.81
G	35 feet of clayey diamicton ($K=10^{-7}$ cm/s) overlying 15 feet of nonfractured, low-permeability shale, limestone, or dolomite	(10)	0.06
		(3)	0.07
		(T)	0.06

Table 1 continued

Designation	Geologic description	Relative ranking	
		(10)	(3)
E	50 feet of clayey diamicton (K=10 ⁻⁷ cm/s)	(10)	0.014
		(3)	0.000
		(T)	0.007
F	20 feet of clayey diamicton (K=10 ⁻⁷ cm/s) overlying 30 feet of nonfractured, low-permeability shale, limestone, or dolomite	(10)	0.000
		(3)	0.000
		(T)	0.000

(10) rating for 10-foot landfill liner design

(3) rating for 3-foot liner design

(T) total rating

-a- simulations not conducted for B and C5 scenarios with 3-foot liner design (see pages 27 and 35)

K hydraulic conductivity value

Table 2 Hydrogeological scenarios for which contaminants from a simulated landfill do not migrate past given compliance distances within 100 years.

	Compliance distance (feet)							
	50	100	150	200	300	400	500	1000
Scenarios	C5b	C5b	A4	A4	A4	A4	A4	A4
in	D	D	C4	C4	C4	C4	C4	A4b
compliance	E	E	C5	C5	C5	C5	C5	B
after 100	F	F	C5b	C5b	C5b	C5b	C5b	C4
years of	G	G	D	D	D	D	D	C5
simulation			E	E	E	E	E	C5b
			F	F	F	F	F	D
			G	G	G	G	G	E
								F
								G

The ranking of the 16 hydrogeological scenarios on their potential for groundwater contamination from land burial of wastes was based on the extent and rate of migration predicted by the PLASM/Random Walk model. The ranking values indicate the relative potential migration for the hydrogeological scenarios, but they may not correspond to actual migration distances for a specific contaminant. Ranking values ranged from 0 to 1000, with the maximum value representing the hydrogeological scenario with the highest predicted potential for contaminant migration. Table 1 is a brief description of each modeled scenario and its ranking value. The highest hydraulic conductivity value (K) used in the modeling is included for each designated scenario.

Based on the numerical approximations of contaminant transport for the 16 modeled hydrogeological scenarios, and subject to the assumptions inherent to those models, the following results and conclusions are presented:

1) Table 2 lists the scenarios for which predicted migration did not exceed a specified compliance distance during the 100-year simulation. Compliance distances ranged from 50 to 1000 feet. For example, predicted migration of all six contaminants modeled for the C5b, D, E, F, and G scenarios was less than 50 feet in 100 years. Migration at these scenarios, therefore, did not exceed a compliance distance of 50 feet or more. All other scenarios modeled for this exercise had migration in excess of a 50-foot compliance distance. The listing of scenarios for various compliance distances in table 2 is based on the contaminant with the greatest predicted migration for either landfill design. For example, predicted migration for all contaminants simulated for both

designs of the C5b scenario was less than 50 feet. If predicted migration for one contaminant in that scenario had been 125 feet, rather than 25 feet, even if only for one of the two designs, the C5b scenario would not have been listed for compliance distances of 50 and 100 feet. Rather, it would have been listed for compliance distances greater than 150 feet.

Predicted migration for the C5b, D, E, F, and G scenarios did not exceed the IPCB-proposed compliance distance of 100 feet during the 100-year simulations. These scenarios also would have been in compliance if the distance were 50 rather than 100 feet. None of these scenarios contained layers representing continuous aquifers. If the compliance distance was expanded to 150 feet, it is predicted that the A4 and C4 as well as C5 and C5b scenarios would also be in compliance after 100 years. The hydraulic conductivity modeled for the A4 and C4 scenarios was 10^{-4} cm/s. Sandstone aquifers with such hydraulic conductivity are often considered to be low-yield aquifers. If initial landfill siting is based on the probability of contaminants migrating beyond the compliance distance, it would be possible, given a 150- to 500-foot compliance distance, to site a landfill over a low-yield aquifer similar to those represented in the A4 and C4 scenarios.

These results indicate that a 100-foot compliance distance may be more protective of low-yield aquifers, such as those modeled for the A4 and C4 scenarios; however, it can be more restrictive in terms of where a landfill could be sited.

2) Predicted migration rates generally were slightly higher for simulations incorporating the 3-foot-thick landfill liner with a leachate collection system than for simulations incorporating the liner 10 feet thick, because the leakance values used to represent the 3-foot liner were greater than those of the 10-foot liner (see page 12).

Concentrations of relatively mobile contaminants in the layers beneath the source area generally were lower for simulations incorporating the 3-foot liner design than for simulations incorporating the 10-foot design. These lower concentrations were due to the lower initial mass of contaminants used to simulate the effects of the leachate collection system in the 3-foot design. Relatively immobile contaminants were subject to greater attenuation in simulations using the 10-foot liner design; thus concentrations in the lower layers were sometimes lower than those predicted with the simulations using the 3-foot liner design.

3) Berg, Kempton, and Cartwright (1984) ranked the potential for groundwater contamination for hypothetical landfills in 18 geologic sequences, based on the hydrogeologic and attenuative properties of the upper 50 feet of geologic materials (fig. 1). The ratings in this report (table 22) are based on mathematically generated predictions of contaminant migration for hydrogeological scenarios typical to Illinois. The predicted migration rates (table 6) show that several sequences mapped by Berg, Kempton, and Cartwright as having a moderate potential for groundwater contamination may be subject to as much or more contaminant migration as those sequences they mapped as having high potential for contamination. Predicted contaminant migration, however, was minimal for those sequences they mapped as having low potential for groundwater contamination.

4) Based on the predicted migration rates of chloride, cadmium, COD, methylene chloride, TCE, and xylene, and given the assumptions and initial conditions of the conceptual and mathematical models used for this study, the following conclusions may be drawn regarding the suitability of certain geologic sequences as sites for sanitary landfill disposal facilities:

- Siting a municipal waste disposal facility would be difficult without exposing the aquifer to a high potential for contamination in an area where a continuous aquifer has a hydraulic conductivity greater than 1×10^{-4} cm/s and is within 35 feet of the ground surface. The predicted migration of all modeled chemical constituents, except cadmium, was extensive for hydrogeological scenarios representative of these areas. This conclusion does not imply that an aquifer overlain by a thicker confining layer will have a low probability of contamination, since such a scenario was not tested.

- Siting a municipal waste disposal facility may be possible without posing a high potential for contamination in areas that contain 1) cemented sandstone that may be overlain by as much as 35 feet of clay-rich diamicton; 2) thick deposits of silty and/or clayey diamicton with discontinuous sand lenses; and 3) thick deposits of sandy loam diamicton, silt-rich loess, or silt-rich lacustrine materials. This conclusion assumes that 1) the landfill is carefully designed to minimize leakage and 2) underlying materials have no pathways of preferential flow (i.e., joints, fractures) that would allow rapid migration of contaminants. Predicted migration of contaminants with conservative to high mobility was limited for hydrogeological scenarios representative of these areas. Little migration was predicted for contaminants with moderate to low mobility.
- The lowest potential for groundwater resource contamination will occur in areas where the uppermost 50 feet of geologic material contains no aquifers and consists of clay-rich diamicton or low-permeability, nonfractured bedrock. Materials such as these generally are not considered to be aquifers, and hydraulic conductivity is typically less than 1×10^{-7} cm/s. The contaminant transport model did not predict appreciable contaminant migration for such areas during the simulated 100-year span.

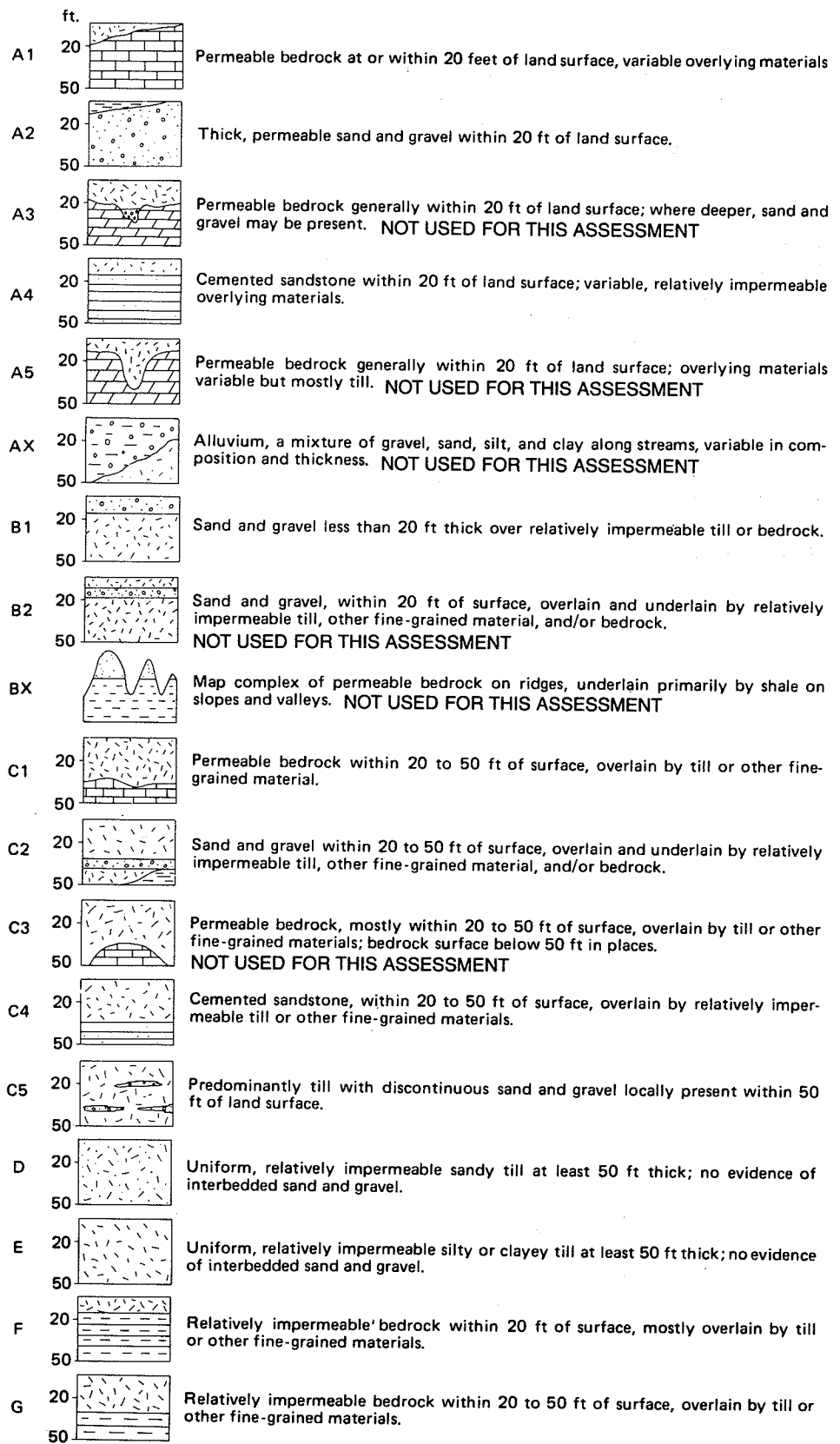

Figure 1 Diagrams of geologic sequences mapped by Berg, Kempton, and Cartwright (1984).

INTRODUCTION

Background

Much effort has been directed toward improving the technical and regulatory aspects of landfill siting in the past two decades. Hughes (1972) presented early technical work on hydrogeologic siting and landfill designs. He recognized the importance of certain hydrogeologic parameters, such as the position of the water table and the hydraulic conductivity of surrounding materials, on the potential for groundwater contamination from a landfill. Cartwright and Sherman (1969) concluded that landfills should be located in materials with low hydraulic conductivity to minimize the movement of leachate. They recommended that such materials underlying the landfill have a minimum thickness of 30 feet. They also presented a map of Illinois, based on the criterion of 30 feet of material having low hydraulic conductivity, that indicated areas where geologic conditions were potentially suitable for waste disposal. Cartwright et al. (1981) noted that the attenuative, as well as the hydrogeologic, properties of the surrounding materials need to be considered when siting a landfill. Berg, Kempton, and Cartwright (1984) mapped the uppermost 50 feet of geologic materials in Illinois and qualitatively ranked the various sequences of these materials for their potential groundwater contamination from land burial of municipal wastes. Their ranking was based on hydrogeologic and attenuative properties.

An example of evolving regulatory requirements designed to reduce the likelihood of groundwater contamination at waste disposal sites is the regulations recently proposed by the Illinois Pollution Control Board (IPCB); these update the regulatory permit requirements and operating standards for owners and operators of solid, nonhazardous waste disposal facilities (Illinois Pollution Control Board, 1988). These proposed regulations contain a combination of design and performance standards. One proposed performance standard is a compliance distance of 100 feet surrounding the waste disposal cell. Applicants for new permits must demonstrate that the proposed waste disposal site will not cause degradation of groundwater beyond this compliance distance for a minimum of 100 years.

Project Objectives

This research set out to quantitatively assess the potential for groundwater contamination from land burial of municipal wastes in hydrogeologic situations common to Illinois. This assessment is an outgrowth of research conducted by Berg, Kempton, and Cartwright (1984). They ranked the potential for groundwater contamination by qualitatively evaluating geologic materials within 50 feet of land surface.

This evaluation uses a numerical approach to quantitatively rate the geologic sequences mapped in the 1984 report. The results of this assessment will provide guidance to help determine whether IPCB's proposed compliance distance of 100 feet is an appropriate regulatory criterion for maximum leachate migration.

Approach and Limitations

The approach used for this project was to numerically simulate contaminant migration for conceptual models of hydrogeological scenarios common to Illinois. The conceptual models were based on geologic mapping by Berg, Kempton, and Cartwright (1984). Sixteen hydrogeological scenarios were modeled incorporating two standardized landfill designs: a 10-foot bottom liner and a 3-foot bottom liner with a leachate collection system. Migration was simulated for six contaminants commonly found in municipal landfill leachate. They are chloride, cadmium, chemical oxygen demand (COD), methylene chloride, trichloroethylene (TCE), and xylene. Migration rates were tabulated at 5-year intervals for the first 50 years and 10-year intervals for the second 50 years for a total simulation time of 100 years. The migration data were used to quantitatively rank 16 hydrogeological scenarios for potential groundwater contamination resulting from land burial of municipal wastes.

The migration rates and corresponding ranking values presented in this report are for generalized hydrogeologic conditions similar to those of the conceptual models, and were subject to the assumptions inherent to the conceptual and mathematical models. They indicate the potential mag-

nitude of contaminant migration that can occur for given hydrogeological situations under the assumptions used for this modeling. These rating values can be used for a regional or preliminary assessment of the susceptibility of a hydrogeologic sequence to potential groundwater contamination from land burial of municipal wastes. The data presented in this report are not applicable to any specific site because of the generalizations (homogenous, isotropic aquifer, etc.) that are required to formulate a "typical" hydrogeologic sequence. Field investigations will always be necessary for assessing the potential for groundwater contamination at a waste disposal site.

DESCRIPTION OF GEOLOGIC SEQUENCES

Background

Berg, Kempton, and Cartwright (1984) mapped the upper 50 feet of geologic materials throughout Illinois. They differentiated and ranked 18 sequences of geologic materials on their potential to restrict the movement of contaminants in groundwater (fig. 1) from generalized hydrogeologic and attenuative properties.

For this study, 12 of these 18 sequences were modeled, with two variations for four of the modeled sequences; therefore, 16 geologic sequences were modeled. The six sequences not modeled were either closely comparable to other modeled sequences, uncommon, or too complex for application to the numerical models used in this project. The sequences that were modeled comprise an estimated 85 to 95 percent of the state's land surface.

The six sequences mapped by Berg, Kempton, and Cartwright (1984) that were not modeled are A3, A5, AX, B2, BX, and C3. Sequences A3, A5, and C3 comprise very small areas within restricted portions of the state; furthermore, A3 and A5 are similar to A1, and C3 is similar to C1. Sequence B2, fairly extensive in south-central Illinois, was not modeled because of its similarity to B1 (both contain sand and gravel in the upper 20 feet, underlain by fine-grained materials). Sequences BX and AX were not modeled because they were too complex for application to the mathematical model. Sequence BX generally consists of permeable deposits that overlie less permeable deposits. It occurs principally in areas of steeply sloping topography in southwestern Illinois. Sequence AX consists of alluvial deposits of variable thicknesses. These alluvial deposits, a mixture of fine- and coarse-grained materials, are highly variable, which makes it extremely difficult to set up a generalized model for the AX sequence. Because coarse-textured materials are common in alluvial deposits, much of sequence AX can be included, conceptually, with sequence A2.

Sequence Descriptions

The following descriptions are based on those of Berg, Kempton, and Cartwright (1984). Table 5 (see page 16) briefly describes how each sequence was generalized for the model.

Sequence A1

Sequence A1 is characterized by bedrock with high hydraulic conductivity (such as sandstone or weathered, jointed, fractured dolomite or limestone) that is within 20 feet of ground surface. The bedrock is primarily Ordovician, Silurian, and/or Mississippian age. Quaternary-age diamicton, loess, and lacustrine materials may overlie the bedrock. Hydraulic conductivities in the bedrock materials are usually greater than 1×10^{-4} cm/s. Hydraulic conductivities in the Quaternary materials are commonly less than 1×10^{-4} cm/s. Sequence A1 occurs primarily in the driftless and thin drift regions of northwestern and north-central Illinois and in upland areas adjacent to the Mississippi and lower Illinois Rivers.

Sequence A2

Sequence A2 is composed of unconsolidated sands and gravels at or near the ground surface and is commonly greater than 50 feet thick. These deposits are primarily Wisconsinan age, but the sequence also includes the Pearl Formation of Illinoian age, the Mounds Gravel of Tertiary age, and sand and gravel of Cretaceous age. Hydraulic conductivities average about 1×10^{-3} cm/s or higher.

Wisconsinan sands and gravels primarily occur within and adjacent to the valleys of major Illinois rivers. Thick Illinoian sands and gravels occur in central-southern Illinois; Tertiary and Cretaceous sands and gravels occur in extreme southern Illinois.

Sequence A4

Sequence A4 contains cemented sandstone within 20 feet of the surface. This sandstone is Pennsylvanian age. Overlying the bedrock is less than 20 feet of diamicton, loess, or lacustrine materials of Illinoian age. Hydraulic conductivities for the sandstone range from 1×10^{-4} to 1×10^{-7} cm/s, and typically average 1×10^{-4} to 1×10^{-5} cm/s. Hydraulic conductivities of the overlying materials are as low as 1×10^{-7} cm/s. Sequence A4 occurs only in southern Illinois.

Sequence B1

Sequence B1 contains less than 20 feet of sand and gravel at the ground surface. Underlying this deposit is fine-grained diamicton or bedrock of low hydraulic conductivity. This sequence occurs mainly in the Wisconsinan till plain as the Batavia and Wasco Members of the Henry Formation, but it is also present in the Illinoian till plain as the Pearl Formation, Hagarstown Member. Hydraulic conductivity of the sand and gravel is generally 1×10^{-3} cm/s or greater; hydraulic conductivity of the underlying diamicton or bedrock may average 1×10^{-7} cm/s or lower. This sequence is predominant in portions of east-central and northeastern Illinois.

Sequence C1

Sequence C1 consists of sandstone or fractured and jointed dolomite and limestone between 20 and 50 feet below ground surface. This bedrock is of Ordovician, Silurian, or Mississippian age. Diamicton or other fine-grained material, primarily Wisconsinan age, overlies the bedrock. Hydraulic conductivities in the bedrock average 1×10^{-4} to 1×10^{-3} cm/s; those in the overlying unconsolidated deposits typically average 1×10^{-7} cm/s. Sequence C1 is mainly in northeastern and west-central Illinois.

Sequence C2

Sequence C2 is characterized by a continuous sand and gravel layer (generally 3 to 10 feet thick) between 20 and 50 feet below ground surface. The sand and gravel is overlain by diamicton or other fine-grained material and underlain by diamicton or bedrock of low hydraulic conductivity. The age of the glacial deposits may be Wisconsinan or pre-Wisconsinan. Some C2 sequences contain sand and gravel beds in loosely compacted Cretaceous and Tertiary deposits. Hydraulic conductivities of the sand and gravel average 1×10^{-3} cm/s; underlying and overlying materials commonly have hydraulic conductivities of about 1×10^{-7} cm/s. Sequence C2 is present throughout central Illinois, and to a lesser extent in extreme southern and northeastern Illinois.

Sequence C4

Sequence C4 consists of cemented sandstone, 20 to 50 feet below ground surface. The sandstone is Pennsylvanian age. Overlying the bedrock is diamicton, lacustrine materials, or loess, most of which is Illinoian. Hydraulic conductivities in the cemented sandstone average 1×10^{-4} to 1×10^{-5} cm/s; those in the overlying unconsolidated materials typically average 1×10^{-7} cm/s. This sequence occurs in southern Illinois.

Sequence C5

Sequence C5 is mapped for both upland and lowland settings. The upland setting consists of locally occurring sand and gravel within 50 feet of the surface and overlain principally by diamicton and loess. The lowland setting consists of lacustrine materials greater than 20 feet thick. These deposits may be Wisconsinan or Illinoian age. Hydraulic conductivities for the sand and gravel in the upland setting average 1×10^{-3} cm/s; accompanying fine-grained glacial deposits average 1×10^{-7} cm/s. In the lowland setting, the hydraulic conductivities of lacustrine materials range from 1×10^{-4} to 1×10^{-6} cm/s and average about 1×10^{-5} cm/s. The underlying materials have conductivities of 1×10^{-7} cm/s. Sequence C5 primarily occurs in southern Illinois.

Sequence D

Sequence D consists of uniform sandy/gravelly diamicton or other fine-grained material greater than 50 feet thick. No distinct deposits of sand and gravel are identified in areas containing this

sequence. The diamicton is typically Illinoian age. Hydraulic conductivities range from 1×10^{-7} to 1×10^{-5} cm/s. This sequence primarily occurs in north-central Illinois.

Sequence E

Sequence E is delineated by 50 feet or more of uniform silty or clayey diamicton or other fine-grained material. Sand and gravel is not identified in areas containing this sequence. The diamicton is Wisconsinan or Illinoian age. Hydraulic conductivities are 1×10^{-7} cm/s or lower. Sequence E occurs in a wide band through central Illinois. It is the most widespread sequence mapped by Berg, Kempton, and Cartwright (1984).

Sequence F

Sequence F contains dense, slightly fractured, shale or limestone within 20 feet of the ground surface. The bedrock is Ordovician or Pennsylvanian age. Overlying the bedrock is less than 20 feet of diamicton, loess, or lacustrine materials, all Wisconsinan or Illinoian age. Hydraulic conductivities for the bedrock are low to very low, range from 1×10^{-7} to 1×10^{-11} cm/s, and average 1×10^{-9} cm/s. The overlying unconsolidated materials average about 1×10^{-7} cm/s. Sequence F occurs in north-central, northwestern, and southern Illinois.

Sequence G

Sequence G consists of shale or nonfractured massive limestone (similar to sequence F) that first occurs between 20 and 50 feet below ground surface. Bedrock materials are either Ordovician or Pennsylvanian age. Overlying the bedrock are diamicton, loess, or lacustrine materials, all Wisconsinan or Illinoian age. Hydraulic conductivities for the bedrock materials range from 1×10^{-7} to 1×10^{-11} cm/s and average approximately 1×10^{-9} cm/s. Hydraulic conductivities in the overlying unconsolidated materials may average 1×10^{-7} cm/s. Sequence G occurs in north-central and southern Illinois.

METHODS OF STUDY

Approach

The classical approach often used in a groundwater modeling project involves 1) model selection, 2) data collection, 3) data preparation for the model, 4) history matching, and 5) predictive simulation (Mercer and Faust, 1980a). The classical approach is intended for modeling a field site with data collected at that site. This project is intended to aid the development of management and regulatory decisions; therefore, it used generalized data for hypothetical settings, and required a modified approach involving 1) model selection, 2) data collection, 3) data preparation for the model, 4) predictive simulation, and 5) model verification.

The first step in each approach is the same. A model must be selected that is applicable to the problem, but it must not be too simple nor too complex for the scenario to be simulated. Models considered for this project were 1) analytical (where an exact solution is obtained for simplified scenarios) and 2) numerical (where an approximate solution is obtained for complex scenarios).

In the classical approach, data are collected in the field and entered into the model. Where field data are inadequate, estimates based on previously published results and experience are used. For this modified approach, the best estimates for all the model input parameters are based on previously published values and experience.

History matching in the classical approach is a means of verifying the results generated by the model. This matching requires that model output, often in the form of hydraulic head, be compared with field-measured data. Obviously, field data on head distribution did not exist for the hypothetical geologic sequences modeled in this project. Output from the numerical model used in this study, therefore, was compared with output from an analytical model (for which an exact, rather than approximate, solution to the contaminant transport equation is obtained), as well as with output from another numerical model. This method of model verification is suggested by Beljin (1985).

The predictive phases of each approach are similar. For the classical approach, certain site conditions (such as a sources of sinks and/or barriers) may be altered spatially or temporally to determine the effectiveness of certain options (such as remedial actions). For this modified approach,

hydrogeologic conditions (hydraulic conductivity, porosity, etc.) were altered, while holding the landfill design and contaminant concentrations constant. This procedure allowed predicted contaminant migration for different scenarios to be compared, and accounted for the various combinations of hydrogeologic conditions discussed in this report.

Numerical Models

Model Selection

Model selection was based on two criteria. First, a code was needed that could compute hydraulic head for multiple-layer scenarios having a range of hydrogeologic characteristics. This code flexibility was necessary because many geologic sequences described in this report contain more than one type of geologic material. A quasi three-dimensional version of the Prickett Lonquist Aquifer Simulation Model (PLASM; Prickett and Lonquist, 1971) satisfied this criterion. Second, the transport of six contaminants was to be simulated through eight types of geologic material, which required a code that would allow for material-dependent values of retardation and porosity. The Random Walk contaminant transport code (Prickett, Naymik, and Lonquist, 1981) satisfied this second criterion. Therefore, PLASM and Random Walk codes were coupled as the primary model for this study. The USGS Method of Characteristics (MOC) model (Konikow and Bredehoeft, 1978) and PLUME, an analytical model (Bumb et al., 1984), were used to verify the PLASM/Random Walk results. PLUME and MOC were chosen because they are well-documented, tested, and readily available.

Model Descriptions

PLASM and Random Walk solute transport model The PLASM/Random Walk model consists of two codes coupled to create one groundwater flow/contaminant transport model. The PLASM code (Prickett and Lonquist, 1971) can simulate steady or transient groundwater flow in up to three dimensions for heterogeneous, anisotropic aquifers under confined, leaky confined, or unconfined conditions. PLASM computes head distribution by using an iterative, alternating-direction, implicit method to solve a set of finite difference equations. The version used for this project is a quasi-three-dimensional version (multiple, two-dimensional layers interconnected by leakage terms), modified to operate on desk top computers (Prickett and Associates, 1984, 1987).

The Random Walk code (Prickett, Naymik, and Lonquist, 1981) simulates contaminant transport three dimensionally. It utilizes a particle-in-a-cell technique for the convective component of the solute transport equation and a random-walk technique for the dispersive component. The version of the code used for this project (Prickett and Associates, 1984, 1987) also includes layer-dependent retardation and porosity terms.

The PLASM and Random Walk codes have been tested and proven valid (Prickett and Lonquist, 1971; Prickett et al., 1981). Assumptions inherent to the codes are

- continuous saturated aquifer
- single-phase flow
- slightly compressible fluid
- negligible thermal and density gradients
- major components of flow parallel to grid axis
- small drawdown compared to thickness of aquifer (horizontal flow in aquifer layers)
- no horizontal flow component for vertical leakage through confining bed
- negligible change in storage in confining bed
- dispersion a random process in porous media
- negligible decay and biodegradation
- fluid density and viscosity independent of solute concentration
- hydrogeologic properties not affected by contaminants.

USGS Method of Characteristics model (MOC) The MOC code (Konikow and Bredehoeft, 1978) simulates groundwater flow and contaminant transport in one or two dimensions for a heterogenous, anisotropic aquifer under steady or transient, confined conditions. An alternating-direction implicit procedure is used to solve a finite difference approximation to the groundwater flow equation. The solute transport equation is solved by the method of characteristics. A particle tracking technique solves the convective term of the solute transport equation. Dispersion, fluid sources and sinks, and divergence of velocity effects on contaminant transport are solved using a two-step explicit procedure to solve a finite difference equation. This code has been tested and proven valid (Konikow and Bredehoeft, 1978). Assumptions inherent to the MOC code are

- continuous saturated aquifer
- single-phase flow
- slightly compressible fluid
- negligible thermal and density gradients
- major components of flow parallel to grid axis
- no component of flow perpendicular to the grid plane
- pumping wells fully penetrating
- dispersion a random process in porous media
- nonreactive solute
- fluid density and viscosity independent of solute concentration
- hydrogeologic properties not affected by contaminants.

The version of the MOC code used for this project (International Ground Water Modeling Center, 1987) includes subroutines that simulate the effects of retardation and decay on contaminant transport.

Analytical model (PLUME) PLUME (version 2.0, In-Situ, Inc., Laramie, Wyoming; Bumb et al., 1984) is a two-dimensional, solute transport code that gives an analytical solution to a two-dimensional advection-dispersion equation. The advection-dispersion equation, in general form, was given by Bumb et al. (1984) and Sternberg (1985). The details of the application of the second-order differential equation used in PLUME were summarized previously by Bumb et al. (1984) and Griffin and Roy (1986). Assumptions inherent to the PLUME code are

- continuous saturated aquifer
- horizontal flow
- steady state single-phase flow
- negligible thermal and density gradients
- major components of flow parallel to grid axis
- aquifer physically and chemically homogeneous and isotropic with constant hydraulic gradient
- dispersion a random process in porous media
- fluid density and viscosity independent of solute concentration
- adsorption a linear function of concentration
- no cosolvent or competitive interactions of contaminants.

Model Configuration

For the PLASM/Random Walk and MOC models, all input data are discretized on a grid. Input data representing the flow system and the contaminants to be modeled are entered for each node of the grid. The program calculates head and concentration values at those nodes. For example, if a grid with 20 rows and 20 columns of nodes is defined, the program will calculate the hydraulic head and contaminant concentration at each node (400 head and 400 concentration computations). These computations will be based on the input parameters and boundary conditions.

For this project, the boundary conditions were specified so that the same grid was applicable to all the geologic sequences except the B sequence. This procedure negated potential grid bias on groundwater flow and contaminant transport, with the one exception.

PLASM/Random Walk model configuration A grid, 50 x 50 nodes horizontally, was established with three layers. Node spacing varied, ranging from 1000 feet at the boundaries to 25 feet downgradient of the nodes representing the landfill (fig. 2). The change in spacing between any two nodes was never greater than a factor of two, a limit recommended by Prickett and Associates (1985) to maintain numerical stability. Total grid dimensions were 8000 x 8000 feet horizontally and 40 or 50 feet (depending on scenario) vertically. The grid was stepped to simulate a change in land surface elevation. If the grid had not been stepped, it would not have been possible to contain the water table within the upper layer. This grid was used for all scenarios except for scenario B.

The B scenario had a similar grid, 50 x 50 x 3 node, 8000 x 8000 x 50 feet, but node spacing ranged from 10 to 1000 feet. This different node spacing is explained in the section on scenario B, page 27.

Two conceptual landfill designs, each 350 x 400 feet, were used in the simulation (fig. 3). The first design featured a bottom liner 10 feet thick. Head buildup within the landfill was set at 10 feet. The liner was simulated by a leakance parameter between layers 1 and 2. The head buildup was simulated by a set of constant head nodes with head set 10 feet above the bottom liner. The second landfill design featured a 3-foot bottom liner with a leachate collection system. The thinner liner of the second design was simulated by using a higher leakance parameter than that of the 10-foot design (see leakance, page 12). The effects of the leachate collection system were simulated by setting heads for all interior landfill nodes 1 foot above the bottom liner. This head value was used because the proposed IPCB regulations require new municipal landfills to be designed so that leachate heads of less than 1 foot can be maintained.

Figure 2 shows the grid boundaries. Constant head boundaries were established at the upgradient and downgradient edges of the grid. Zero-flux boundaries were established lateral to groundwater flow and at the base of the lowest layer. For initial conditions, head at the interior nodes was set at a value intermediate to the values at the constant head boundaries.

The PLASM/Random Walk model was run in two stages. First, the PLASM model was run until steady-state heads were achieved. For the PLASM code, steady state is approximated by running very long time steps. Frind and Matanga (1985) state that for long-term transport problems, the assumption of steady state becomes acceptable. The steady-state head values were then input to a Random Walk preprocessor, and groundwater velocities were calculated. Second, the Random Walk model simulated contaminant transport from the PLASM-derived velocities using steps of 5 years for the first 50 years and 10 years for the last 50 years. Total simulation time was 100 years. Sensitivity tests showed the choice of time step had little effect on the results (fig. 4).

The PLASM/Random Walk model tabulated migration distances and average concentrations for each time step, and reported migration distances to the nearest node. Because of this artifact, which is inherent to the code, the tabular and graphical results sometimes will appear disproportionate. Random Walk calculated concentration data at each node, based on the number of particles (mass of contaminants) and volume of fluid represented by that point. No smoothing routine was used.

For this analysis, concentrations were averaged and tabulated for the line of nodes 100 feet directly downgradient of the landfill nodes. This 100-foot distance was chosen to coincide with IPCB's proposed compliance distance.

MOC configuration The MOC code computes head and contaminant concentration for two-dimensional groundwater flow. In this study, the MOC code was set to solve for cross-sectional rather than for plan view, flow, and transport. The grid used for the MOC simulations was 20 nodes horizontally by 12 nodes vertically. The model required node spacing to be constant in any single dimension. Horizontal node spacing values of 50, 100, 250, and 500 feet were used

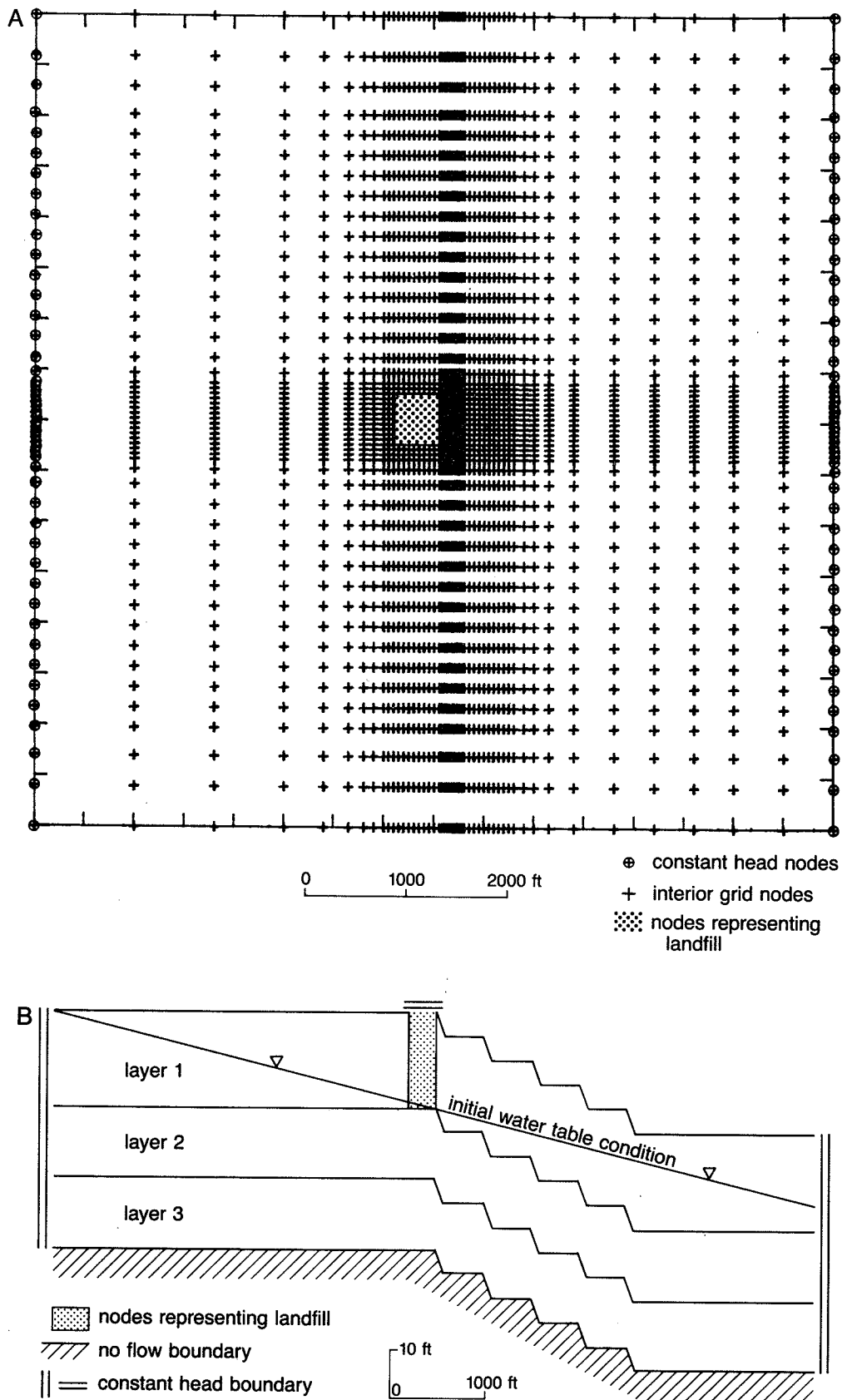

Figure 2 Plan (A) and cross-sectional (B) views of the grid used for PLASM/Random Walk simulations.

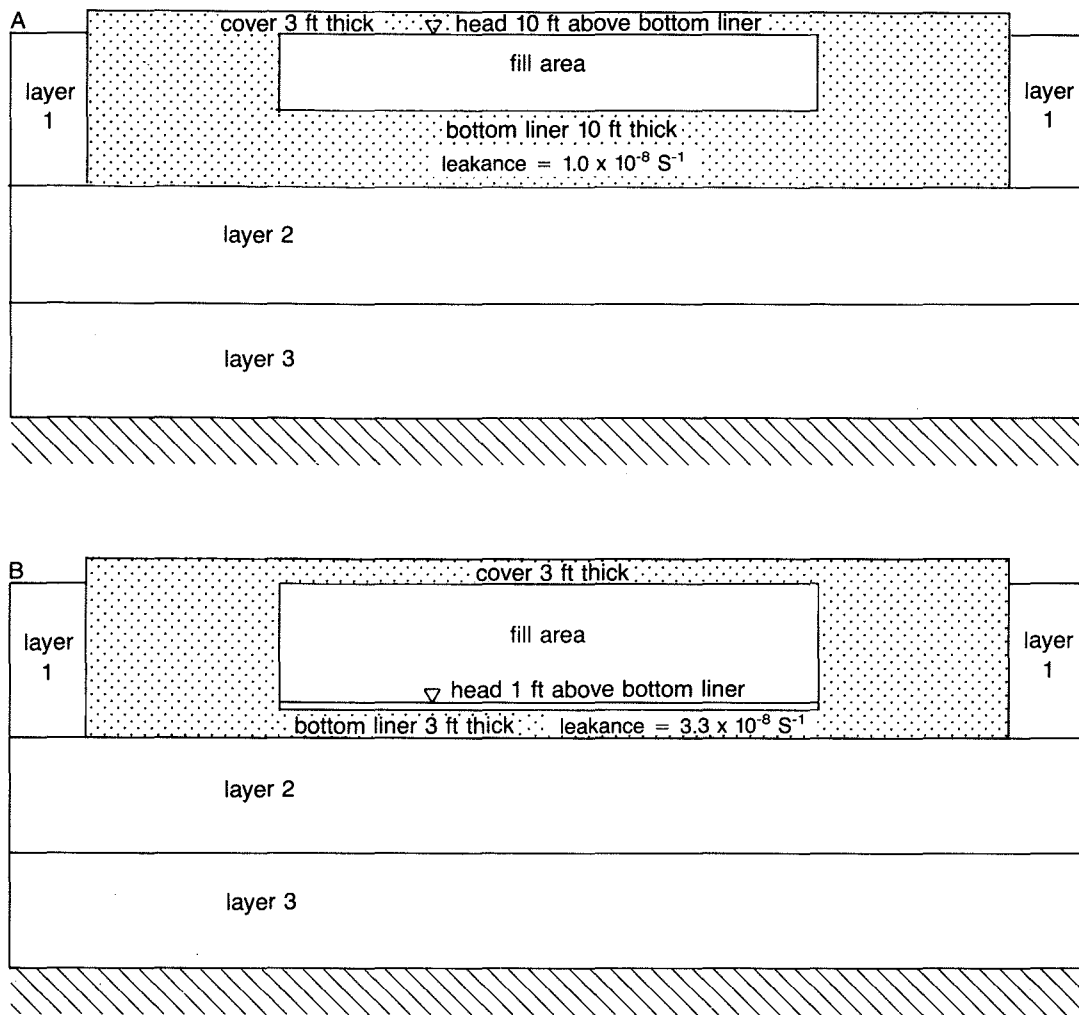

Figure 3 Schematic cross sections of the 10-foot (A) and 3-foot (B) landfill liner designs. A leachate collection system is approximated for 3-foot liner design by setting head at 1 foot (rather than 10 feet) above the bottom liner.

depending on the anticipated migration distance. When large migration distances required horizontal spacing of 250 or 500 feet, a second run was conducted using a horizontal node spacing of 100 feet. This second run provided data on migration close to the landfill source area during the early stages of the simulation. Vertical node spacing was set at 5 feet, and total vertical thickness was 50 feet. The width was set at a value of 1 length-unit.

The waste disposal cell was simulated by a set of nodes representing an area 400 feet long by 10 feet deep, the same dimensions used in the PLASM/Random Walk simulation. The bottom liner was simulated with two rows of nodes, representing 10 feet vertically and having a hydraulic conductivity of 1×10^{-7} cm/s. Only the landfill design with a 10-foot bottom liner was simulated. Total trench depth was 20 feet.

The upgradient and downgradient edges of the grid were programmed as constant head boundaries, and set to values that would cause gradients similar to those of the PLASM/Random Walk model. All other boundaries were zero-flux. Initial head was set intermediate to the constant head boundaries. Figure 5 shows the grid used for this model.

The groundwater flow routine of the model was set to calculate steady-state head. The transport routine was then executed with simulated time steps of 10 years. Total simulation time for the model was 100 years.

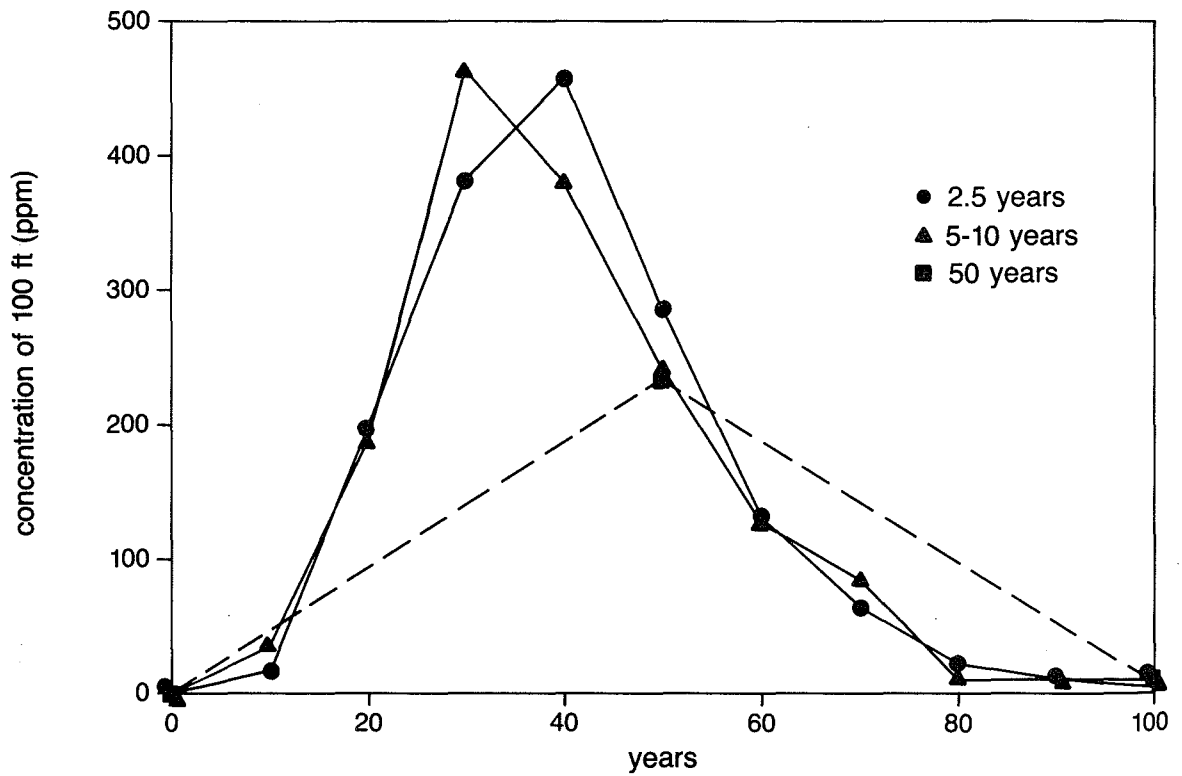
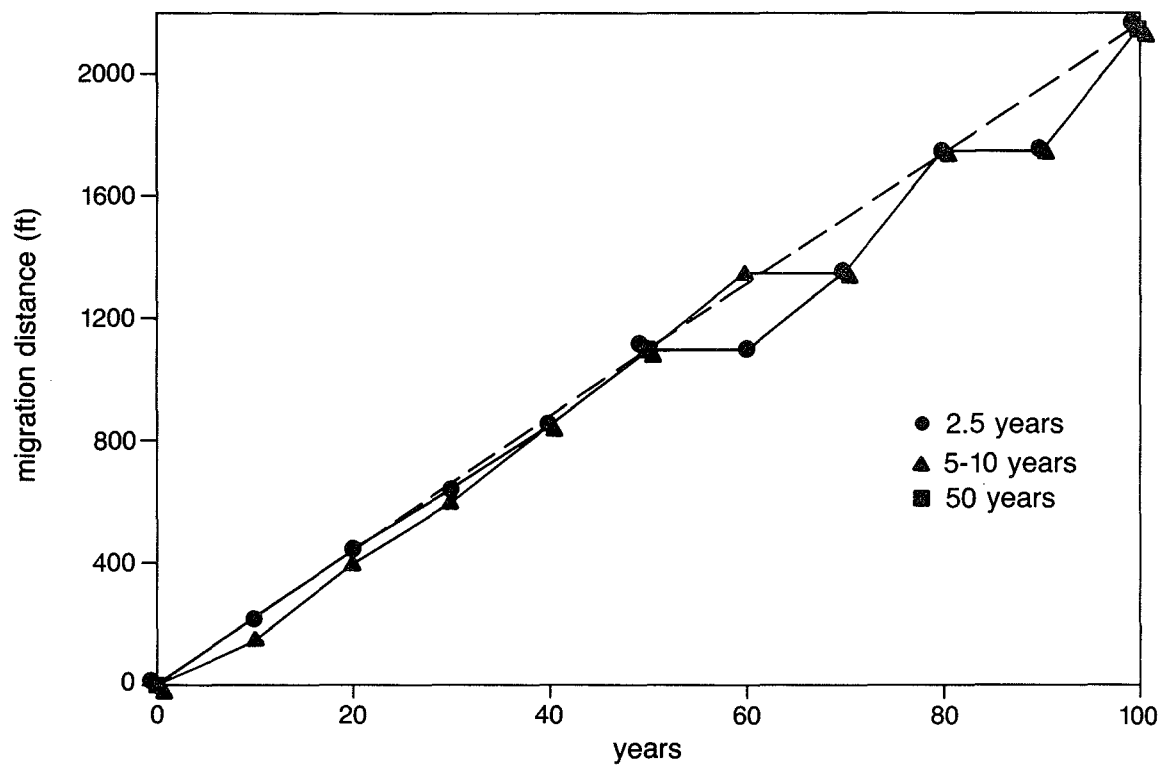

Figure 4 Sensitivity of PLASM/Random Walk simulations to length of time steps. Plots show average chloride concentration 100 feet downgradient of the source area and maximum plume extent for the A2 scenario. Time steps are 10 steps of 5 years and 5 steps of 10 years (100 simulated years), 40 steps of 2.5 years, and 2 steps of 50 years. All except the 50-year time-step data are plotted at 10-year intervals.

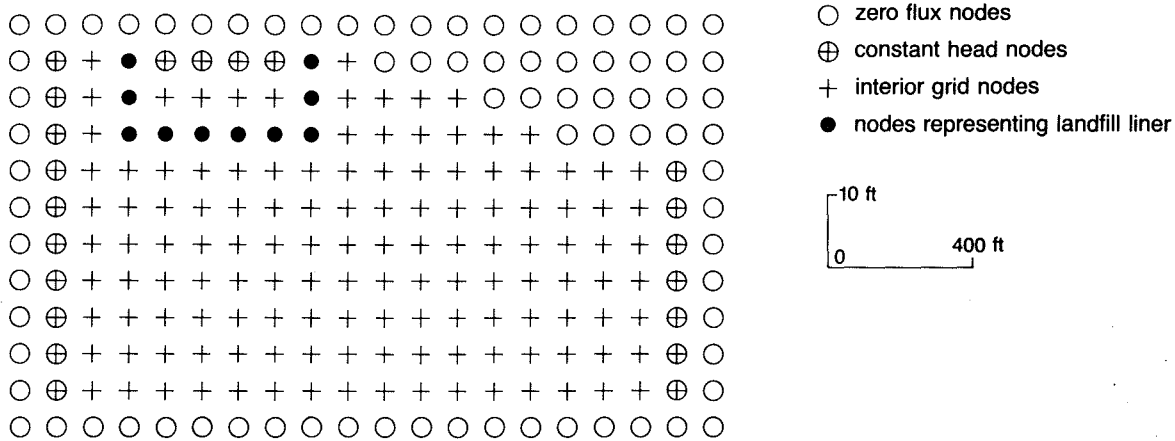

Figure 5 Cross-sectional view of the grid used for the MOC simulations.

PLUME configuration PLUME was used to solve analytically contaminant migration in simple, single-layer cases. This solution provided verification of the PLASM/Random Walk results. Verification tests were conducted for chloride migration and the 10-foot landfill liner design.

PLUME does not solve for hydraulic head; it incorporates a user-specified groundwater velocity value in the advection-dispersion equation. This velocity is equal to the product of the hydraulic conductivity and the hydraulic gradient, divided by the porosity of the media being modeled. The velocity values used for PLUME simulations were calculated from the gradient, hydraulic conductivity, and porosity values used in the PLASM/Random Walk and MOC simulations.

Landfill designs could not be incorporated into the PLUME model, so the flux of contaminants to the groundwater flow system was calculated at rates approximating those predicted by the numerical models. For the A1, A2, and A4 scenarios, the mass flux rates decreased with an approximate 6-year half-life for a time span of 50 years. The mass flux rate for the C5b, D, E, and F scenarios decayed linearly to zero during a 100-year period. A direct input of mass was used for PLUME simulations rather than allowing mass to breach the simulated liner as in the PLASM/Random Walk and MOC simulations. Assumptions, therefore, were made that 1) no attenuation of contaminants occurs in the landfill or liner, 2) contaminants instantaneously enter the groundwater flow system, and 3) the water table was at or above the base of the liner.

Data Collection and Preparation

Most of the input data used in the model simulations are from published sources. Because a range of values was usually listed for each parameter, it was often necessary to choose a value considered typical or average. If information on what a typical or average value might be was not available, an environmentally conservative value was chosen (i.e., the value from the range that would generate the greatest transport of contaminants).

Computational Parameters

Time Steady-state conditions are approximated with the PLASM code by assigning long time steps. For these simulations, eight time steps of 500,000 days were used. Simulated time for the Random Walk simulations was 100 years (using data generated by PLASM during its eighth time step). MOC and PLUME did not require long time steps for steady-state approximations and were set for 100-year simulations.

Error value The error value is a test of model convergence. The project used an error value of 50 with PLASM. This value, obtained empirically, was considered to be conservative (so that more iterations than necessary were performed). If the change in head was equal for every node on the grid, an error value of 50 on a grid with 50 X 50 X 3 nodes would equate to a head change of 0.0067 feet per node. The error value for MOC was .01 (.00005 ft/node). PLUME uses an analytical solution that does not require an error value.

Table 3 Hydraulic conductivity (from Berg, Kempton, and Cartwright, 1984) and porosity (from Walton, 1965) values input to PLASM and Random Walk.

Geologic material	Hydraulic conductivity (cm/s)	Porosity
Fractured limestone/dolomite	1×10^{-3}	0.15
Sand or highly permeable sandstone	1×10^{-3}	0.30
Sandstone	1×10^{-4}	0.25
Cemented sandstone	1×10^{-5}	0.25
Silt	1×10^{-5}	0.45
Silty-clay or sandy loam	1×10^{-6}	0.30
Clay	1×10^{-7}	0.30
Shale	1×10^{-9}	0.05

Physical Flow Parameters

Hydraulic conductivity The hydraulic conductivity values listed in table 3 are typical for geologic materials commonly found in Illinois, and are based on the assumption that flow is through continuous porous media. This assumption may not be appropriate for a limestone or dolomite aquifer where flow is primarily through fractures, joints, and bedding planes. For this exercise, the fractures are assumed to be spaced such that, on a large scale, the fractured aquifer approximates a continuous porous media. This assumption is supported by Mercer and Faust (1980b).

Storativity The PLASM code required that a non-zero value for storage coefficient be entered. The storage coefficients used were 0.23 for unconfined sand and 0.14 for unconfined limestone. These are typical values according to Todd (1980). The storage coefficient for all confined and confining materials was 1×10^{-4} to 1×10^{-5} . This range is typical for confined materials (Freeze and Cherry, 1979). Sensitivity analyses showed transport of contaminants predicted by the PLASM/Random Walk model configured for this exercise to be insensitive to the storage coefficient. The storativity value used for MOC was 0.0. This storativity value causes the program to solve a steady-state head distribution.

Recharge/withdrawal The assumption was made that the volume of recharge to the groundwater flow system was negligible compared to the volume of water in the system. It was also assumed that no water supply wells, nor the cone of depression from such wells, existed within the area of the hypothetical landfill. These steady-state simulations, therefore, did not include recharge and withdrawal.

Leakance The leakance term is used in PLASM to calculate flow between layers. With the PLASM code, leakance proved to be an extremely sensitive parameter, greatly affected by the vertical head differential between layers. Therefore, a value of zero was entered everywhere except for beneath the landfill nodes. This simplification resulted in no vertical flow of groundwater at non-landfill nodes during the PLASM modeling. Despite this restriction, the model predicted realistic head values in each layer because groundwater flow was controlled by the constant head boundaries. Random Walk requires vertical gradients for particle movements between layers, so leakance values between layers 1 and 2 and layers 2 and 3 were entered. These values were calculated for non-landfill nodes according to the following equation (modified from Prickett and Associates, 1987):

$$L = \frac{2}{\frac{b_1}{K'_1} + \frac{b_2}{K'_2}}$$

where:

- L = leakage between the layers (units = 1/T)
- b₁ = thickness of layer 1 (L)
- b₂ = thickness of layer 2 (L)
- K'₁ = vertical hydraulic conductivity of layer 1 (L/T)
- K'₂ = vertical hydraulic conductivity of layer 2 (L/T).

The vertical hydraulic conductivity of layers representing clays and shales was assumed to be equal to the horizontal hydraulic conductivity (based on Freeze and Cherry, 1979). The vertical hydraulic conductivity of layers representing aquifers was set to equal 0.01 of the horizontal hydraulic conductivity. This assumption is reasonable on a large scale for many indurated and non-indurated clastic aquifers that may be stratified (Davis, 1969). This assumption may not be valid for cases where flow is predominantly through vertical fractures.

The leakage values for the landfill liners were constants (see fig. 3), which were dependent on the thickness and vertical hydraulic conductivity of the simulated liners (Prickett and Associates, 1987):

$$L = K' / b'$$

where:

- L = leakage of the simulated liner
- K' = vertical hydraulic conductivity of the confining layer (1×10^{-7} cm/s)
- b' = thickness of the confining layer (3 or 10 ft, 0.9 or 3 m).

Initial head Values for head were entered at the constant head boundaries such that the horizontal hydraulic gradient (units = L/L) was 0.005. This value falls within the range of horizontal gradients typical to Illinois (0.01 to 0.001, Cartwright, 1987). Head differentials between layers for PLASM simulations resulted in vertical gradients of 0.5 to 0.67 in confining layers and 0.0 to less than 0.1 in aquifers. The 0.67 value is slightly higher than the upper value of 0.5 commonly observed in fine-grained glacial tills and cited by Freeze and Cherry (1979, p.151). The slight vertical gradient used for aquifers is consistent with the assumption of primarily horizontal flow.

Physical Transport Parameters

Velocity Random Walk and MOC calculate velocity from the hydraulic conductivity, porosity, and hydraulic gradient at each node. PLUME calculates a global velocity from the hydraulic conductivity and porosity of the materials being modeled (table 3), and a gradient of 0.005.

Porosity Table 3 lists the porosity values used in the model; they are from ranges compiled by Walton (1985). The porosity values for the sand, silt, clay, and sandstones are from the low end of the published ranges because a low porosity value causes a larger estimate of contaminant migration. The porosity value for shale, which was modeled as an aquitard, was set at 0.05, the middle of the published range for this type of material. Porosity for fractured carbonate aquifer rocks was assumed to be 0.15. This estimate is supported by data compiled by Schmoker, Kryshtinik, and Halley (1985), which show carbonate porosity values to be typically between 0.07 and 0.178. The relatively high porosity of 0.15 reflects the assumption that the fractured carbonate rocks that make up the aquifer are weathered, as is the case in northern Illinois.

Porosity values input to this model were for total, rather than effective, porosity. Effective porosity is preferable, especially in clay, but no reliable data on effective porosity exist. A sensitivity test has shown that for a scenario consisting of only clay, the use of an assumed effective porosity of .10 rather than the total porosity of .30 increased chloride migration from 25 to 75 feet. For scenarios with sand aquifers, the change from total to effective porosity was insignificant because the effective porosity of sand is very close to its total porosity.

Dispersivity Walton (1985) gives a formula for estimating longitudinal dispersivity (10 percent of plume migration). The models used for this simulation allow only one dispersivity value; therefore, a dispersivity value of 10 feet was selected. According to Walton's (1985) formula, a dispersivity

value of 10 feet would represent dispersion 100 feet from the source area. This distance was of interest because it coincides with IPCB's proposed landfill compliance distance of 100 feet.

Transverse and vertical dispersivity were set at 1 foot. These values are higher than those recommended by Walton (1985). Sensitivity tests showed that the predicted maximum extent of migration was insensitive to dispersivity values between 0.1 and 5 feet (transverse) and 5 and 50 feet (longitudinal), although concentration and plume width were slightly affected.

Chemical Transport Parameters

Contaminants Transport of six contaminants was simulated for each modeled sequence of geologic materials. The contaminants were chloride, cadmium, COD (chemical oxygen demand), methylene chloride, trichloroethylene, and xylene. They represent a range in mobility and toxicity characteristics, and are commonly found in significant concentrations in leachate from municipal waste disposal cells (based on Ham, 1986).

Initial concentration The initial concentrations for the six contaminants are from data compiled by Ham (1986), who listed the ranges of many constituents commonly found in leachates of municipal landfills. Values selected for this project are from the high end of those ranges. All simulations in this project used the following initial contaminant concentrations (ppm):

Cl	Cd	COD	Methylene chloride	TCE	Xylene
3000	0.4	90000	20	0.6	0.15

Retardation factors These values were calculated according to the method outlined by Griffin and Roy (1986, 1987) and using the equations:

$$K_d = K_{oc} * f_{oc}$$

and:

$$R = 1 + [(D_b * K_d) / n]$$

where:

- K_d = partition coefficient
- K_{oc} = soil-water adsorption constant
- f_{oc} = organic carbon fraction
- D_b = bulk density
- n = porosity
- R = retardation coefficient

Table 4a lists retardation coefficients, and table 4b lists the data used to compute the values.

Major Assumptions

Assumptions are necessary for numerical modeling of groundwater flow. Assumptions allow generalization of complex hydrogeologic conditions into a format that can be approximated by a numerical model. In addition to the assumptions inherent to the models used in this project, several assumptions were necessary when formulating the conceptual models. Because these assumptions are common to all scenarios, the relative results of the modeling are not affected.

Assumptions Related to the Conceptual Landfill

The landfill was assumed to occupy about 3.2 acres. Records in the Illinois landfill inventory (Dixon et al., 1986) show that more than 50 percent of the landfills in Illinois are less than 10 acres; median size is approximately 8 acres. The area (350 x 400 feet) used for these simulations approximated the size of a common disposal cell that might be found in Illinois. The area of the

Table 4a Retardation factors input to Random Walk model.

Geologic material	Retardation factor						
	Cl	Cd	COD	Methylene chloride	TCE	Xylene	set
Fractured limestone or dolomite	1.00	81.7	1.16	1.20	3.45	5.74	1
Sand	1.00	62.0	1.31	1.23	2.41	5.47	2
Sandstone	1.00	80.2	1.40	1.30	2.81	7.99	3
Cemented sandstone	1.00	80.2	1.40	1.30	2.81	7.99	3
Silt	1.00	33.4	1.16	1.12	1.74	3.86	4
Silty-clay	1.00	607.0	1.61	1.76	5.61	18.80	5
Clay	1.00	607.0	1.61	1.76	5.61	18.80	5
Shale	1.00	4941.0	5.94	7.18	38.50	146.00	6

Table 4b Data sets used to compute retardation factors.

set	n	D _b	f _{oc}	K _{oc}					
				Cl	Cd	COD	M-Cl	TCE	Xyl.
1	.15	2.42	.005	0	1000	2.0	2.5	30.4	58.8
2	.30	1.86	.0015	0	6667	33.3	25	152	588
3	.25	1.98	.0015	0	6667	33.3	25	152	588
4	.45	1.46	.0015	0	6667	33.3	25	152	588
5	.30	1.82	.005	0	20000	20	25	152	588
6	.05	2.47	.005	0	20000	20	25	152	588

landfill should not affect the extent of downgradient migration predicted by the models, but only the width and concentration of the plume.

The bottom of the landfill liner (trench depth) was assumed to be 20 feet below ground surface. This assumption is supported by Berg, Kempton, and Stecyk (1984) and Berg, Kempton, and Cartwright (1984), who also used 20 feet as a typical trench depth in Illinois.

Boundary conditions were set such that the initial water table was at the base of the landfill (fig. 2). In field situations, the water table does not necessarily occur at that depth; it is a highly site-specific parameter. Placement of a water table at the base of the landfill is an environmentally conservative assumption because it enhances migration. If the water table was higher than the fluid level in the landfill, the gradient could be inward, and few, if any, contaminants would escape. If the water table was positioned below the base of the landfill, contaminant transport would occur as a wetting front through the unsaturated zone, a process that would delay the migration of contaminants to the underlying saturated materials.

Assumptions Related to Hydrogeologic Parameters

The hydrogeology of the geologic sequences was simplified to allow development of conceptual models that could be represented by the mathematical models. The hydraulic conductivity of the materials modeled in this exercise can vary by orders of magnitude with respect to location and/or direction. Likewise the porosity, dispersivity, retardation, hydraulic gradient, and other factors affecting groundwater flow and contaminant transport can vary. The values used for these simulations were chosen because they represent typical values of hydrogeologic parameters found in Illinois. Field studies of the mapped areas generally will yield different hydrogeologic parameters than those used here.

Table 5 Summary of scenarios modeled for each geologic sequence. Hydrogeologic properties used for simulated geologic units are listed on page 6.

Geologic sequences		Hydrogeological scenarios	
Sequence designation	Geologic description	Scenario designation	Simulated hydrogeologic units
A1	Highly permeable bedrock within 20 feet of ground surface	A1	20 feet of sand overlying 30 feet of highly fractured limestone
A2	Highly permeable sands and gravels at or near ground surface	A2	20 feet of clay overlying 30 feet of sand
		A2b	50 feet of sand
A4	Cemented sandstone within 20 feet of ground surface	A4	20 feet of clay overlying 30 feet of cemented sandstone
		A4b	20 feet of clay overlying 30 feet of sandstone
B1	Surficial sand and gravel, less than 20 feet thick, underlain by material of low hydraulic conductivity	B	20 feet of sand overlying 30 feet of clay
C1	Highly permeable bedrock, 20 to 50 feet below ground surface, overlain by fine-grained materials	C1	35 feet of clay overlying 15 feet of fractured limestone
C2	Continuous sand and gravel 20 to 50 feet below ground surface, overlain by fine-grained materials	C2	30 feet of clay overlying 10 feet of sand
		C2b	35 feet of silty clay overlying 15 feet of sand
C4	Cemented sandstone overlain by 20 to 50 feet of fine-grained materials	C4	35 feet of clay overlying 15 feet of cemented sandstone
C5	Upland: locally occurring sand and gravel within 50 feet of ground surface, overlain by fine-grained materials	C5	50 feet of clay with discontinuous sand lens 15 feet thick and 35 feet below ground surface
	Lowland: lacustrine deposits greater than 20 feet thick	C5b	35 feet of silt overlying 15 feet of clay
D	Greater than 50 feet of sandy diamicton	D	50 feet of sandy loam
E	Greater than 50 feet of silty or clayey diamicton	E	50 feet of clay
F	Shale within 20 feet of ground surface overlain by fine-grained materials	F	20 feet of clay overlying 30 feet of shale
G	Shale or dense limestone overlain by 20 to 50 feet of fine-grained materials.	G	35 feet of clay overlying 15 feet of shale

Table 6 Maximum extent of contaminant migration for all scenarios, as calculated by the PLASM/Random Walk model. Maximum extent is determined from the model output by the node-point of non-zero concentration farthest from the source area. Simulation time is 100 years. Distance is downgradient from the set of nodes representing the landfill.

a. 10-foot liner design - no leachate collection, 10 feet of head in landfill (distance in feet)

	Chloride	Cadmium	COD	Methylene chloride	Trichloro-ethylene	Xylene
A1	3950	0.0	3450	2950	1100	550
A2	2150	0.0	1350	1750	750	100
A2b	2150	0.0	1750	1750	700	75
A4	100	0.0	75	25	0.0	0.0
A4b	350	0.0	250	300	100	0.0
B	425	50	425	675	375	325
C1	2550	0.0	2150	1750	50	0.0
C2	1750	0.0	1350	1350	175	0.0
C2b	2150	0.0	1350	1350	300	0.0
C4	25	0.0	1	1	0.0	0.0
C5	100	0.0	0.0	0.0	0.0	0.0
C5b	25	0.0	25	25	1	1
D	25	0.0	25	1	0.0	0.0
E	1	0.0	0.0	0.0	0.0	0.0
F	0.0	0.0	0.0	0.0	0.0	0.0
G	1	0.0	0.0	0.0	0.0	0.0

b. 3-foot liner design - leachate collection, 1 foot of head in landfill (distance in feet)

	Chloride	Cadmium	COD	Methylene chloride	Trichloro-ethylene	Xylene
A1	3950	25	3450	3450	1350	850
A2	2550	1	2150	1750	1100	550
A2b	2150	0.0	1750	1750	1100	500
A4	100	0.0	50	50	1	1
A4b	550	0.0	400	450	200	75
C1	2950	0.0	2950	2550	1350	750
C2	1750	0.0	1350	1350	1100	450
C2b	2550	0.0	1750	2150	1100	450
C4	125	0.0	75	75	1	0.0
C5b	1	0.0	1	1	1	1
D	25	0.0	1	0.0	0.0	0.0
E	0.0	0.0	0.0	0.0	0.0	0.0
F	0.0	0.0	0.0	0.0	0.0	0.0
G	1	0.0	0.0	0.0	0.0	0.0

Note: B and C5 hydrogeological scenarios were not simulated with the 3-foot landfill design.

RESULTS

Hydrogeological Scenarios

The hydrogeological scenarios discussed in this section are based on hypothetical models of the hydrogeologic sequences presented earlier. Table 5 summarizes these hydrogeological scenarios and corresponding geologic descriptions. Table 6 summarizes the maximum extent of contaminant migration predicted by the PLASM/Random Walk model for the modeled hydrogeological scenarios. Appendix A is a complete listing of contaminant migration and concentration predicted 100 feet downgradient from the source. Representative head and plots of

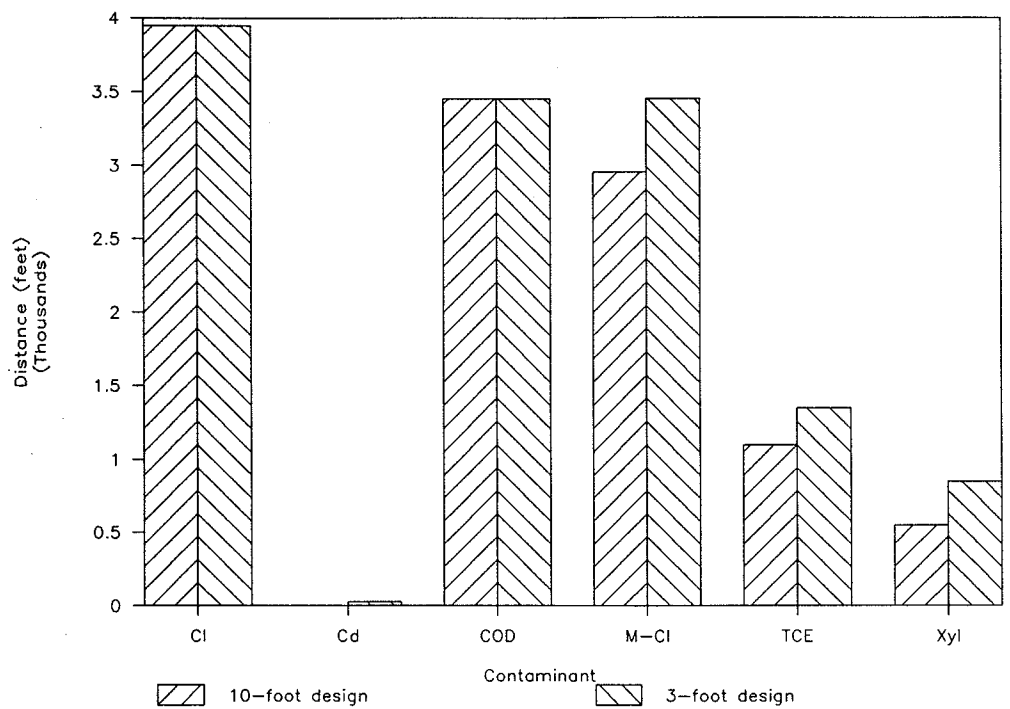

Figure 6 Maximum extent of contaminant migration predicted for the A1 scenario by PLASM/Random Walk (simulated time = 100 years).

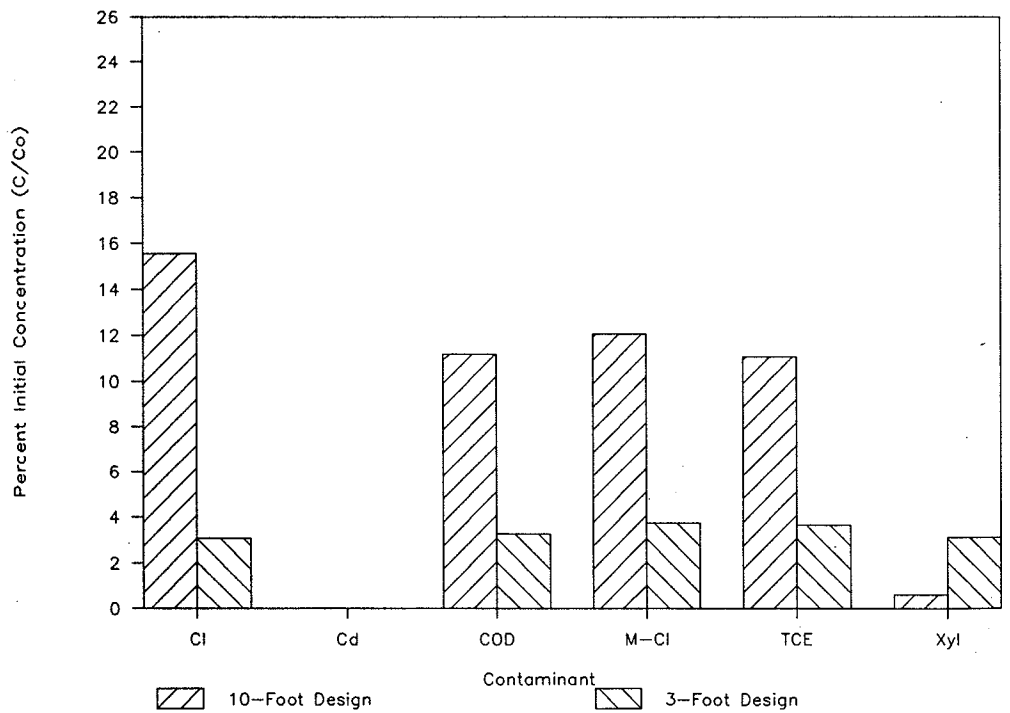

Figure 7 Maximum concentrations of contaminants 100 feet from the source area of the A1 scenario predicted by PLASM/Random Walk (at any time during 100-year simulation).

concentration distribution for the individual scenarios are shown in Appendix B. A complete set of head and distribution plots is on open file at the Illinois State Geological Survey.

A1 Scenario

The conceptual model for the A1 scenario was 20 feet of unconsolidated sand overlying 30 feet of highly fractured limestone or dolomite (table 5). The sand and the highly fractured carbonate unit represent aquifers. The A1 sequence as mapped by Berg, Kempton, and Cartwright (1984) could also represent a highly permeable sandstone; however, the hydrogeologic parameters for such a sandstone would be more similar to those used with the A2 scenario. Fractured carbonate bedrock was used for the conceptual model of this scenario because its relatively low porosity (0.15) differentiates it from the higher porosity (0.30) sands and sandstones of the A2 scenario.

For this and the following scenarios, the hydrogeologic conditions were discretized for the PLASM/Random Walk grids in three layers. The first 20 feet of simulated hydrogeology (table 5) and the nodes representing the landfill (particle source area) were discretized for the uppermost layer. The hydrogeologic parameters of the 30 feet of materials underlying the landfill nodes were discretized for the lower two layers of the grid.

Head distributions for the A1 scenario are presented in appendix B. These figures show that little mounding of groundwater occurs for this scenario.

The PLASM/Random Walk simulation predicted extensive migration for all contaminants except cadmium (fig. 6). The maximum extent of migration predicted for this scenario was 3,950 feet for chloride. Predicted migration for all contaminants, except cadmium, was past IPCB's proposed 100-foot compliance distance after 15 years. Predicted migration distances were high for this scenario because 1) the relatively high hydraulic conductivity and low porosity values representing the fractured carbonate resulted in relatively high groundwater velocity; 2) the source was situated directly on the aquifer; thus there was no confining layer, other than the liner, where contaminants could be attenuated; and 3) retardation factors for the fractured carbonate rock were lower than for materials such as clay and shale.

Figure 7 shows the highest concentrations predicted 100 feet downgradient of the source area, as a percentage of initial concentration for each contaminant. Concentrations predicted for this scenario were generally high because a large flux of simulated contaminants entered the aquifer during a short time, and dilution, which is dependant on porosity, was low. Concentrations predicted for the 3-foot liner design were generally lower than those predicted for the 10-foot design because the initial input of mass to the 3-foot design was less, simulating the effects of that design's leachate collection system (see page 7). For xylene, however, greater retardation during particle movement through the thicker 10-foot liner reduced overall particle migration such that concentrations predicted for the 3-foot liner design were higher.

The PLASM/Random Walk predictions of concentration and migration for this scenario were tested with PLUME and MOC. Table 7 shows the results of this comparison. Only chloride migration for the 10-foot liner design was tested. Limitations of the MOC and PLUME models (see page 6) precluded testing of other contaminants or testing for the 3-foot liner design.

Migration distances predicted by the three models were within 150 feet after 100 years of simulation. The concentrations predicted by PLUME probably differ due to the way contaminant loading to the aquifer was estimated (for example, no attenuation in the liner was assumed for PLUME simulations, see page 11).

It would be very difficult to site a landfill in an area with hydrogeologic conditions similar to those approximated in this scenario without adversely affecting the aquifer. If introduced to the aquifer, all but the least mobile contaminants could migrate more than 100 feet from the landfill. The potential for groundwater contamination resulting from land disposal of wastes at sites with hydrogeologic sequences similar to those modeled for the A1 scenario may be very high relative to the other modeled scenarios.

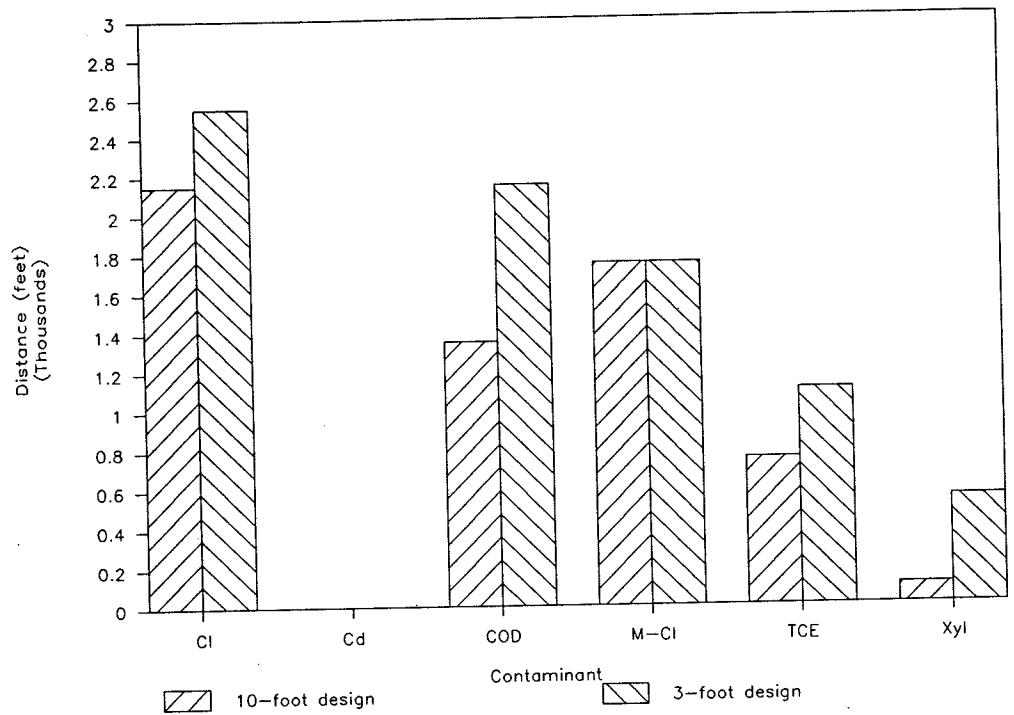

Figure 8 Maximum extent of contaminant migration predicted for the A2 scenario by PLASM/Random Walk (simulated time = 100 years).

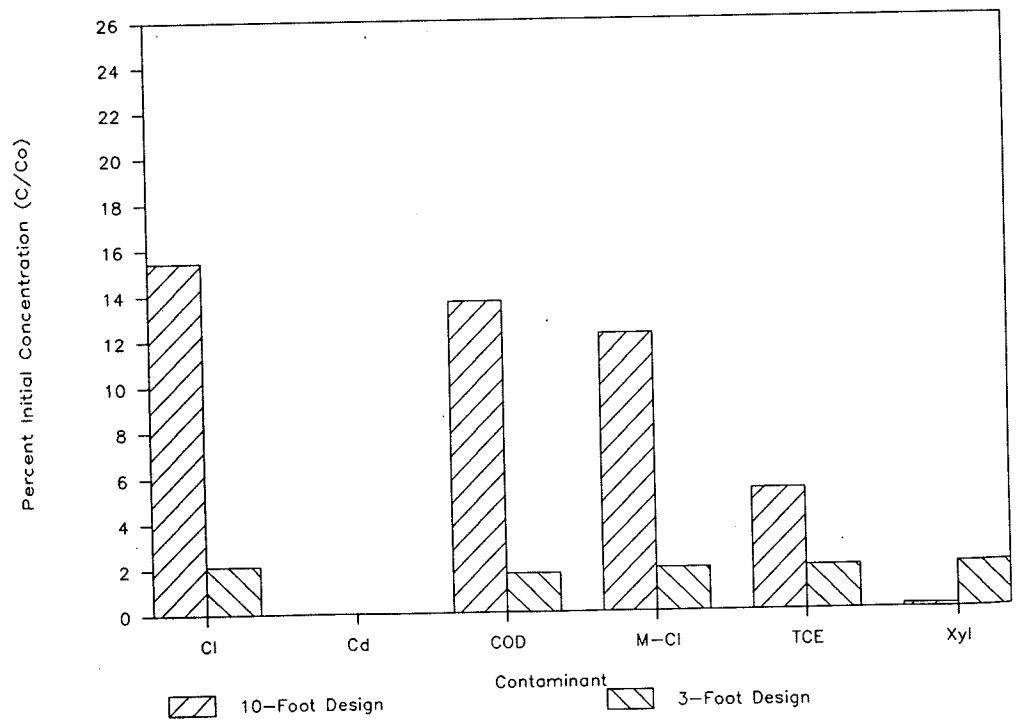

Figure 9 Maximum concentrations of contaminants 100 feet from the source area of the A2 scenario predicted by PLASM/Random Walk (at any time during 100-year simulation).

Table 7 Comparison of PLASM/Random Walk results to PLUME and MOC results for chloride, A1 scenario, 10-foot liner design. Horizontal node spacing was 100 feet for MOCa and 500 feet for MOCb simulations.

Time (years)	Chloride plume extent (feet)				Chloride concentration 100 feet from source area (ppm)		
	PLASM	PLUME	MOCa	MOCb	PLASM	PLUME	MOCa
10	300		450	500	71	910	322
20	750		850	1000	300	720	564
30	1100		***	1500	469	250	401
40	1750		***	2000	313	75	244
50	2150		***	2500	130	25	140
60	2550		***	2500	76	10	75
70	2950		***	3000	36	5	43
80	2950		***	3500	14	1	24
90	3450		***	3500	14	0	13
100	3950	3850	***	4000	0	0	7

*** migration past grid boundary (1100 feet from simulated landfill)

A2 Scenario

The conceptual model used for the A2 scenario was 20 feet of clay-rich diamicton overlying 30 feet of sand or highly permeable sandstone. The sand or highly permeable sandstone represented an aquifer. This conceptual model differed from the sequence mapped by Berg, Kempton, and Cartwright (1984); therefore, a second variation (A2b) of the scenario was run.

The aquifer simulated for the A2 scenario was highly transmissive. Thus, leakage from the nodes simulating the landfill was quickly conveyed downgradient in the aquifer, and no mounding was predicted beneath the landfill. Predicted migration of all contaminants, except cadmium, was up to and past the proposed 100-foot compliance distance by the end of the 100-year simulation (fig. 8). Chloride, COD, methylene chloride, and trichloroethylene migrated past the proposed 100-foot compliance distance within 30 years. The migration rates predicted for this scenario by the PLASM/Random Walk model were high due to 1) high groundwater velocity resulting from the relatively high hydraulic conductivity used to represent the sand aquifer; 2) the placement of source nodes (representing the landfill) directly above the aquifer, which caused no confining layer where contaminants could be attenuated; and 3) low retardation factors for the sand.

Predicted concentrations (fig. 9) for this scenario generally were slightly lower than those for other scenarios with similar plume extent. The lower concentrations were due to the relatively thick (30 feet compared to 10 or 15 feet at the C scenarios) aquifer modeled for this scenario, relatively high porosity (0.30 compared with 0.15 at the A1 and C-1 scenarios), and rapid particle migration that prevented a buildup of particles in any one location. As with the A1 scenario, the predicted concentrations of all contaminants, except xylene, for the landfill design incorporating a leachate collection system were lower than for the design without a leachate collection system. The PLASM/Random Walk predictions of chloride concentration and migration for the 10-foot liner design of this scenario were tested with PLUME and MOC. Table 8 shows the test results.

Migration rates predicted by the three models compare favorably. Concentrations were more comparable than for the A1 scenario, especially between the two numerical models. All three models predicted maximum concentrations (100 feet from the source area) would occur 20 to 30 years after the simulation has begun. By 80 years, predicted concentrations are quite low.

It would be very difficult to locate a landfill at a site such as modeled for the A2 scenario without greatly risking aquifer degradation. This risk is attributed to the high advection rate in the aquifer and the lack of a confining layer between the aquifer and the landfill. If introduced to the aquifer, all but the least mobile contaminants could migrate past IPCB's proposed 100-foot compliance distance within 100 years. The potential for groundwater contamination resulting from land burial of wastes at sites with hydrogeologic sequences similar to the A2 scenario may be high relative to the other scenarios.

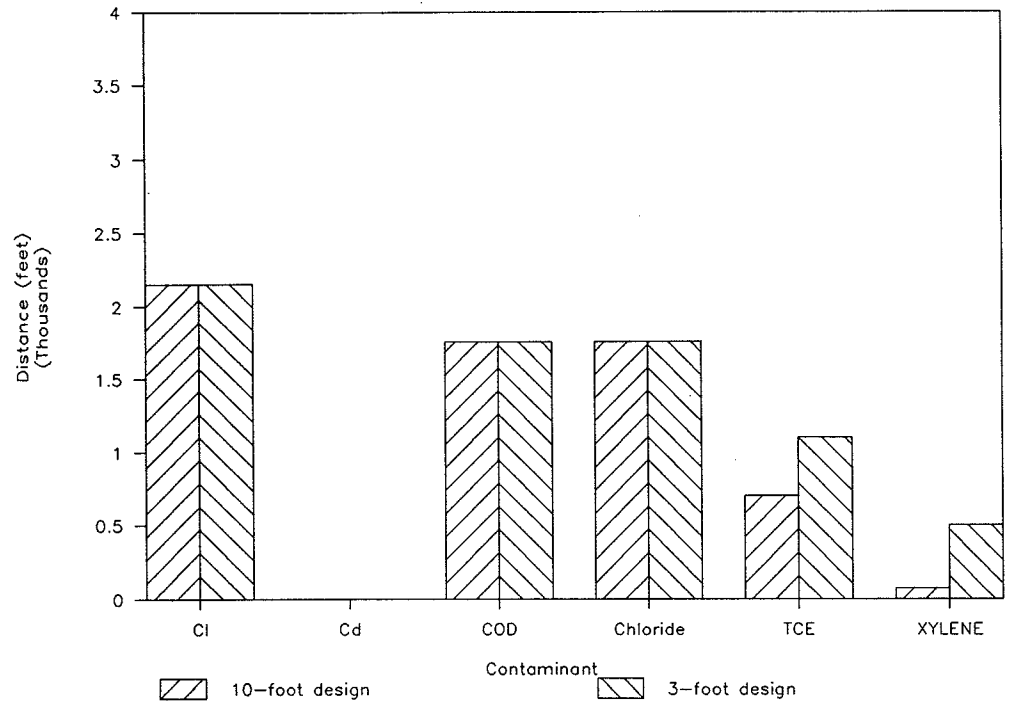

Figure 10 Maximum extent of contaminant migration predicted for the A2b scenario by PLASM/Random Walk (simulated time = 100 years).

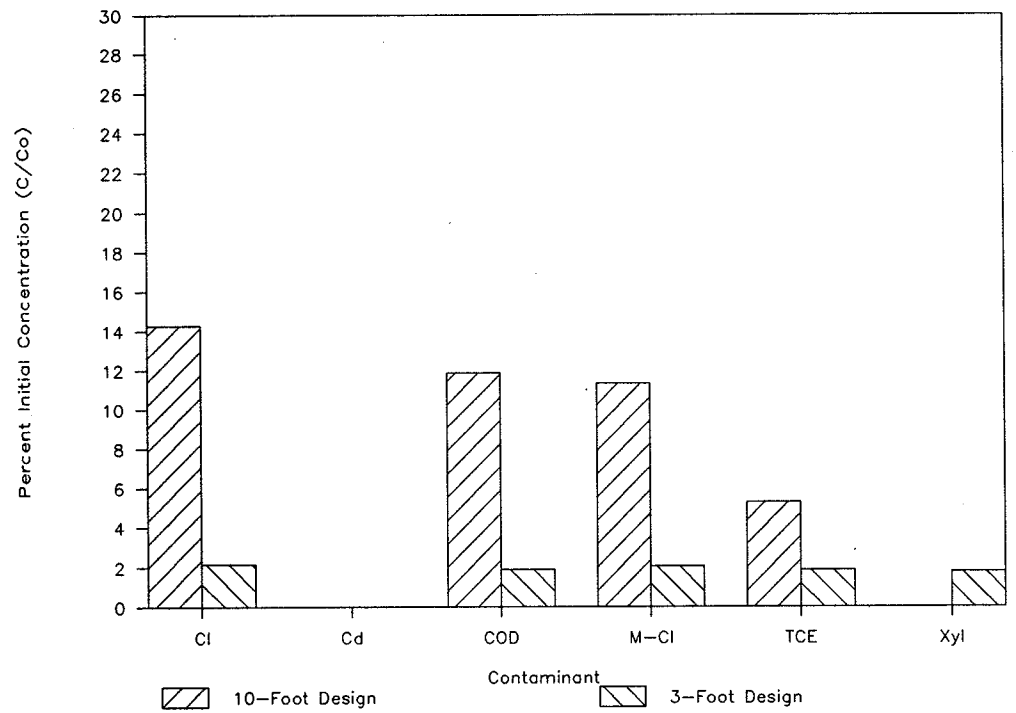

Figure 11 Maximum concentrations of contaminants 100 feet from the source area of the A2b scenario predicted by PLASM/Random Walk (at any time during 100-year simulation).

Table 8 Comparison of PLASM/Random Walk results to PLUME and MOC results for chloride, A2 scenario, 10-foot liner design. Horizontal node spacing was 100 feet for MOCa and 250 feet for MOCb simulations.

Time (years)	Chloride plume extent (feet)				Chloride concentration 100 feet from source area (ppm)		
	PLASM	PLUME	MOCa	MOCb	PLASM	PLUME	MOCa
10	150		250	250	18	180	226
20	400		550	500	188	680	467
30	600		750	750	463	650	462
40	850		950	1000	380	315	331
50	1100		***	1250	241	130	208
60	1350		***	1500	127	35	122
70	1350		***	1500	85	10	65
80	1750		***	1750	11	5	36
90	1750		***	2000	11	1	19
100	2150	2000	***	2250	4	0	10

*** migration past grid boundary (1100 feet from simulated landfill)

A2b Scenario

The conceptual model for the A2b scenario was 50 feet of sand or highly permeable sandstone, all of which represents an aquifer. This hydrogeological scenario more closely approximated the geologic sequence mapped by Berg, Kempton, and Cartwright (1984; table 5) than the A2 scenario.

Migration distances predicted for this scenario (fig. 10) were slightly higher than those for the A2 scenario, but predicted concentrations 100 feet from the source area (fig. 11) were similar (table 9). The difference in migration rates between the A2 and A2b scenarios resulted from the low hydraulic conductivity and high retardation values used to represent the clay unit of the A2 scenario. Those parameters caused a slight "drag" effect for the few particles that entered the clay layer. This effect did not occur in the A2b scenario because there was no layer of low hydraulic conductivity.

The results for the A2b scenario were very similar to those of the A2 scenario because much of the particle migration occurred in the lower two layers where hydrogeologic parameters were identical. Very few particles migrated in the uppermost layer, which represented clay-rich diamicton in the A2 scenario and sand in the A2b scenario.

The results of this simulation suggest that clay-rich surficial materials will not have a significant effect on leachate migration from landfill trenches deeper than these materials are thick. The potential for groundwater contamination resulting from land disposal of wastes at sites with hydrogeologic conditions similar to those modeled for the A2b scenario are expected to be high.

A4 Scenario

The conceptual model used for the A4 scenario is 20 feet of clay-rich diamicton overlying 30 feet of cemented sandstone. The hydraulic conductivity of the cemented sandstone may be typical of a low-yield aquifer. As with the preceding scenarios, the landfill was situated directly on the aquifer; however, the hydraulic conductivity of the simulated aquifer was lower than for the preceding scenarios.

A groundwater mound occurred in the layers below the simulated landfill for this scenario (fig. 12) because the aquifer was only moderately transmissive. Predicted contaminant migration for this scenario was not extensive (fig. 13). Advection rates were low because the hydraulic conductivity used to represent the cemented sandstone was relatively low compared to the A1 and A2 scenarios.

Only chloride was predicted to migrate to the proposed 100-foot compliance distance; however, the center of mass of the chloride plume was still beneath the source nodes. If the simulation had

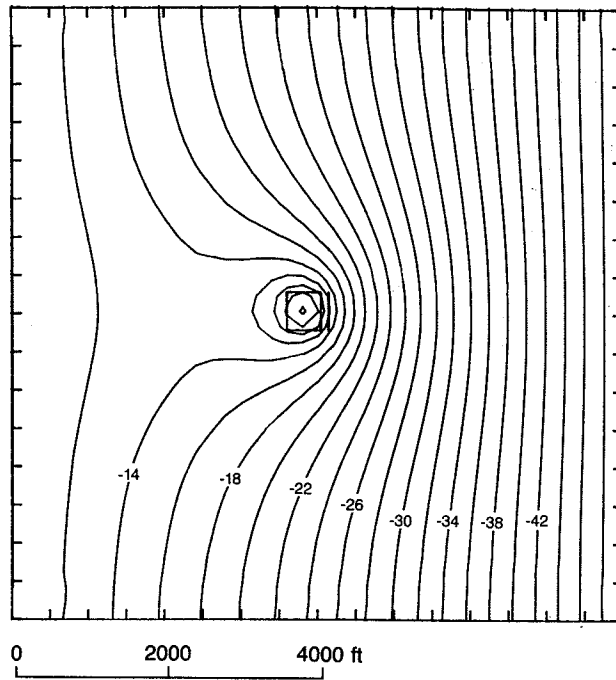

Figure 12 Steady-state head distribution predicted for the A4 scenario by PLASM. Note mound beneath landfill area.

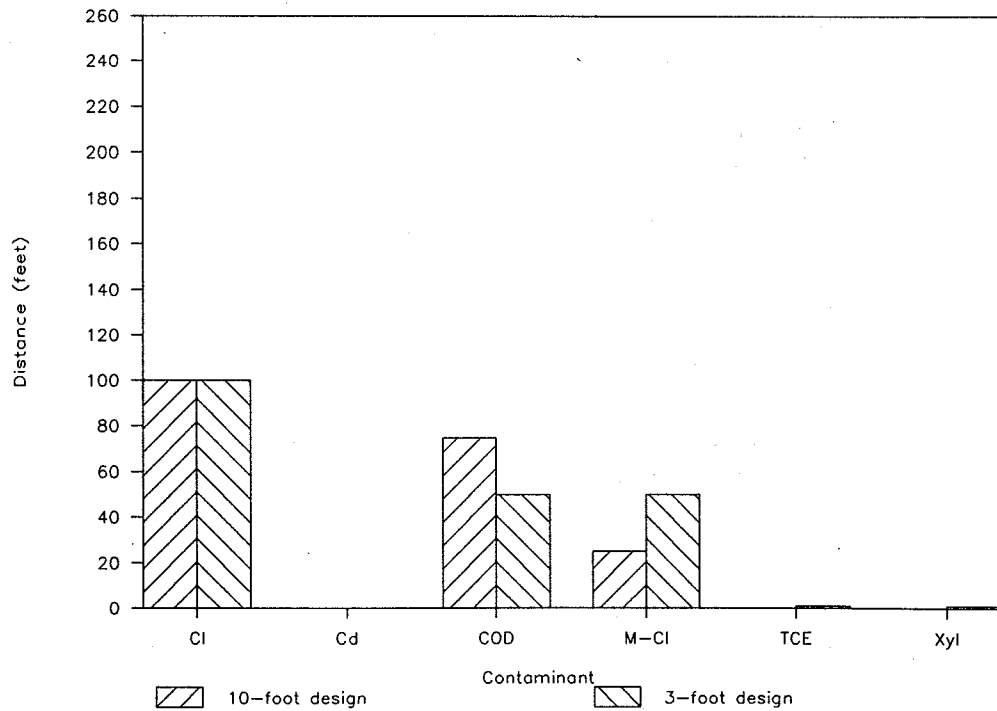

Figure 13 Maximum extent of contaminant migration predicted for the A4 scenario by PLASM/Random Walk (simulation time = 100 years).

Table 9 Comparison of maximum contaminant concentrations 100 feet downgradient of the source area for the A2 and A2b scenarios. Note the similarities in predicted concentrations and migration distances for the two scenarios.

Contaminant	10-foot liner design		3-foot liner design	
	Maximum concentration (ppm)	Maximum extent (feet)	Maximum concentration (ppm)	Maximum extent (feet)
	A2-A2b	A2-A2b	A2-A2b	A2-A2b
Chloride	463-427	2150-2150	62.9-64.8	2550-2150
Cadmium	(a)-(a)	0-0	(a)-(a)	1-0
COD	12,294-10,686	1350-1750	1,526-1,694	2150-1750
Methylene chloride	2.44-2.27	1750-1750	0.380-0.411	1750-1750
Trichloroethylene	0.0322-0.0317	750-700	0.0115-0.0112	1100-1100
Xylene	0.000224-(a)	100-75	0.00297-0.00267	550-500

(a) Predicted migration does not reach the 100-foot compliance distance within the 100-year simulation period.

been conducted for more than 100 years, concentrations of chloride and other contaminants at the proposed 100-foot compliance distance probably would have been higher.

The PLASM/Random Walk predictions of chloride concentration and migration for the 10-foot liner design of this scenario were tested with both PLUME and MOC. Table 10 shows the results.

Migration distances predicted by the three models vary by less than a factor of three. PLUME results, however, showed no contaminants at the proposed 100-foot compliance distance during simulation. These results indicate that the A4 scenario represents a borderline situation where minor differences in hydrogeologic conditions may determine whether or not contaminants can migrate past the proposed compliance distance.

Predicted contaminant migration for the A4 scenario was minimal during the simulated 100-year interval. It is possible, however, that a release of contaminants at a site such as modeled here could eventually degrade water quality in the aquifer at the proposed compliance distance. The relatively low hydraulic conductivity of the cemented sandstone limits migration of contaminants; however, the absence of a clay-rich confining layer increases the probability of contaminant release into the aquifer. High concentrations of contaminants were recorded below the source area during this simulation. The potential for groundwater contamination resulting from land burial of wastes at sites with hydrogeologic conditions similar to the A4 scenario may be moderate.

A4b Scenario

This simulation evaluated the potential for groundwater contamination for a sandstone aquifer with higher hydraulic conductivity than that of the A4 scenario. The conceptual model used for the A4b scenario was 20 feet of clay-rich diamicton overlying 30 feet of sandstone (hydraulic conductivity one order of magnitude greater than the cemented sandstone of the A4 scenario).

Groundwater mounding, similar to the A4 scenario, occurred in this scenario. In the simulation, particles representing chloride, COD, methylene chloride, and trichloroethylene migrated past the proposed 100-foot compliance distance during the 100-year interval of the model (fig. 14). This migration was possible because 1) the sandstone aquifer of the scenario was represented by layers with moderately high hydraulic conductivity, 2) the source area was situated directly over the aquifer nodes, so there was no confining layer where contaminants could be attenuated; and 3) retardation factors for the sandstone were lower than those for materials such as clay and shale.

Figure 15 lists the maximum concentrations predicted for each contaminant. The concentrations predicted for the landfill design with a leachate collection system generally were lower than those

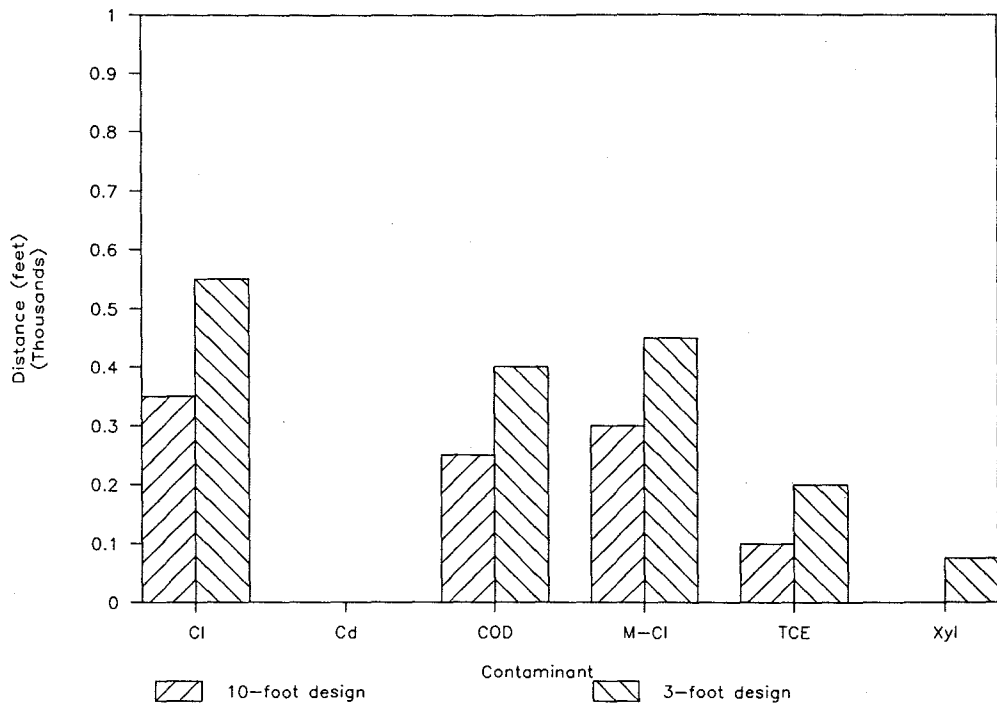

Figure 14 Maximum extent of contaminant migration predicted for the A4b scenario by PLASM/Random Walk (simulated time = 100 years).

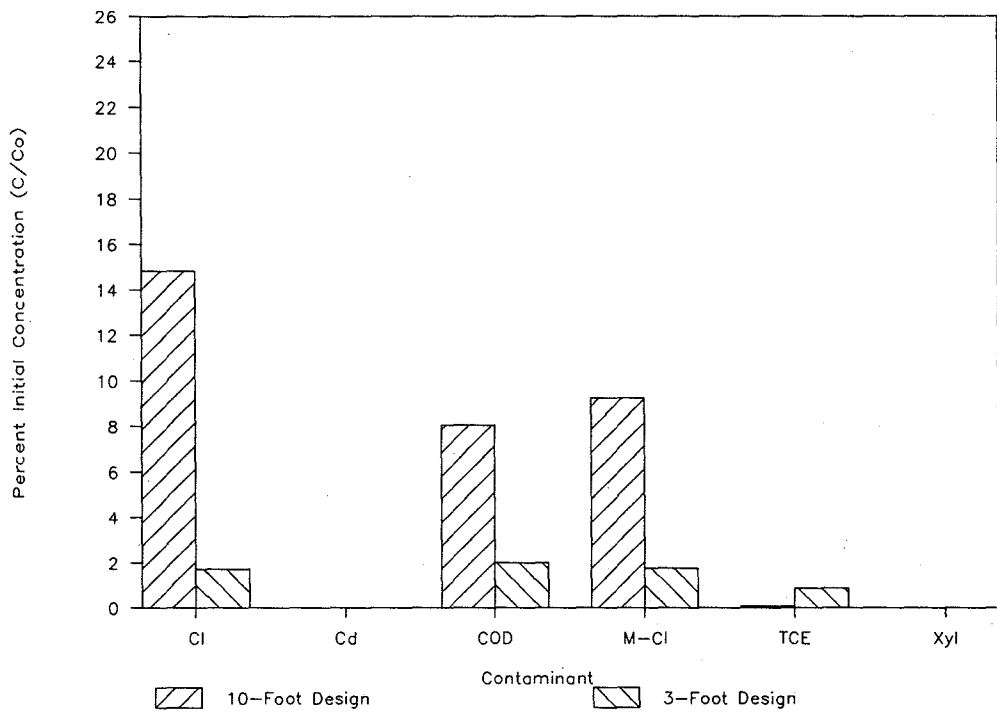

Figure 15 Maximum concentrations of contaminants 100 feet from the landfill source area of the A4b scenario predicted by PLASM/Random Walk (at any time during 100-year simulation).

Table 10 Comparison of PLASM/Random Walk results to PLUME and MOC results for chloride, A4 scenario, 10-foot liner design. Node spacing for MOC is 50 feet.

Time (years)	Chloride plume extent (feet)			Chloride concentration 100 feet from source area (ppm)		
	PLASM	PLUME	MOC	PLASM	PLUME	MOC
10	0		0	0	0	0
20	0		1	0	0	0
30	1		1	0	0	0
40	25		50	0	0	0
50	50		50	0	0	0
60	50		100	0	0	3
70	75		100	0	0	7
80	75		100	0	0	8
90	100		100	2.7	0	12
100	100	65	150	10.7	0	27

predicted for the design without a leachate collection system. For trichloroethylene, however, greater retardation during particle movement through the thicker 10-foot liner (of the design without leachate collection) reduced overall particle migration such that concentrations predicted for the design with the leachate collection system (and 3-foot liner) were higher.

The results of the A4b scenario indicate greater particle migration than for the A4 scenario because the hydraulic conductivity of the aquifer of the A4b scenario is greater. Predicted migration of chloride, COD, methylene chloride, and trichloroethylene was more than 100 feet from the edge of the simulated landfill. Predicted migration of xylene was as much as 75 feet and with time, will reach the proposed compliance distance of 100 feet. Other parameters, such as an increased gradient, could also cause greater migration than predicted for the A4 scenario. Potential for groundwater contamination may be moderate to high for an area with hydrogeologic conditions similar to the A4b scenario.

B Scenario

The conceptual model for the B scenario is 20 feet of unconsolidated sand overlying clay-rich diamicton or bedrock of low hydraulic conductivity. The sand unit represents an aquifer. Because this scenario has an aquifer overlying low permeability materials, rather than vice versa, a different grid (see page 7) was needed to account for lateral, rather than downward, leakage through the liner.

A 3-foot liner design was not modeled for this scenario because a solution (convergence) could not be attained with the redesigned PLASM grid.

Predicted flow in the sand aquifer was not greatly affected by leakage from the source area. A significant groundwater mound, however, occurred in the underlying clay units. The low hydraulic conductivity of these units did not allow for dispersal of head caused by seepage through the bottom liner.

Predicted migration for chloride, COD, methylene chloride, trichloroethylene, and xylene was beyond IPCB's proposed 100-foot compliance distance (fig. 16) during the simulation. These migration distances were affected by downward movement of particles to the layers representing clay-rich diamicton or low-permeability bedrock. Those particles exhibited very little migration in the lower layers because the hydraulic conductivity values were low and retardation values were high. This phenomenon was more pronounced with increased distance from the source nodes. If the particles had not moved in the lower layers, the migration distances probably would have been similar to the A2 and A2b scenarios because 1) the sand unit of this scenario was represented by high hydraulic conductivity, 2) the source area was situated directly in the aquifer; thus there was no confining zone of clay-rich materials where contaminants could be attenuated, and 3) retardation factors for the sand were lower than for materials such as clay and shale. Figure 17

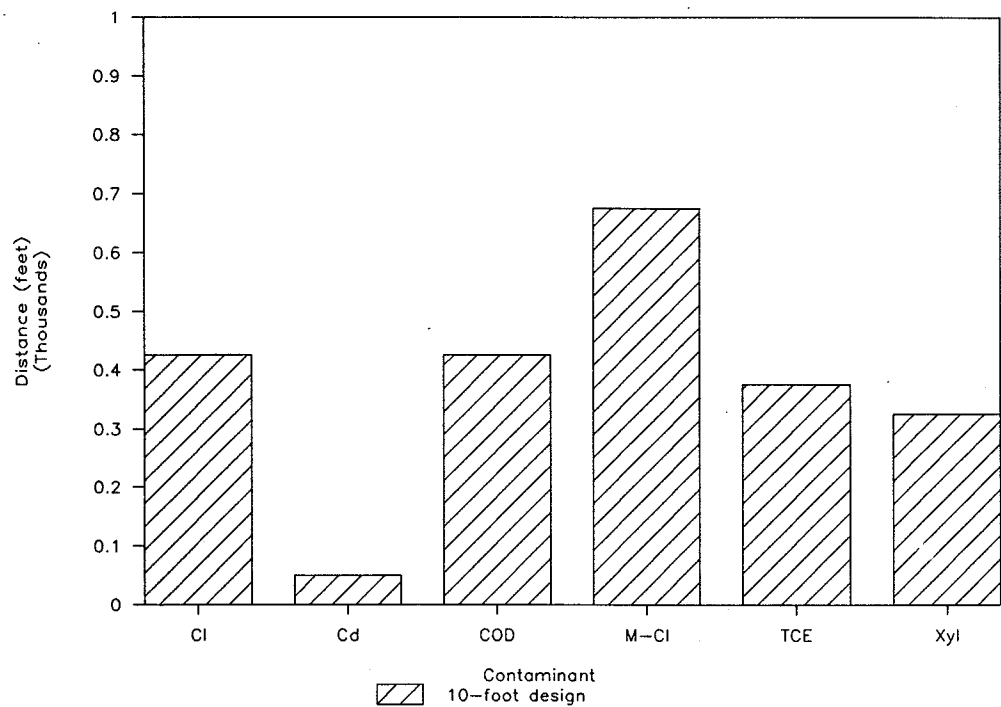

Figure 16 Maximum extent of contaminant migration predicted for the B scenario by PLASM/Random Walk (simulated time = 100 years).

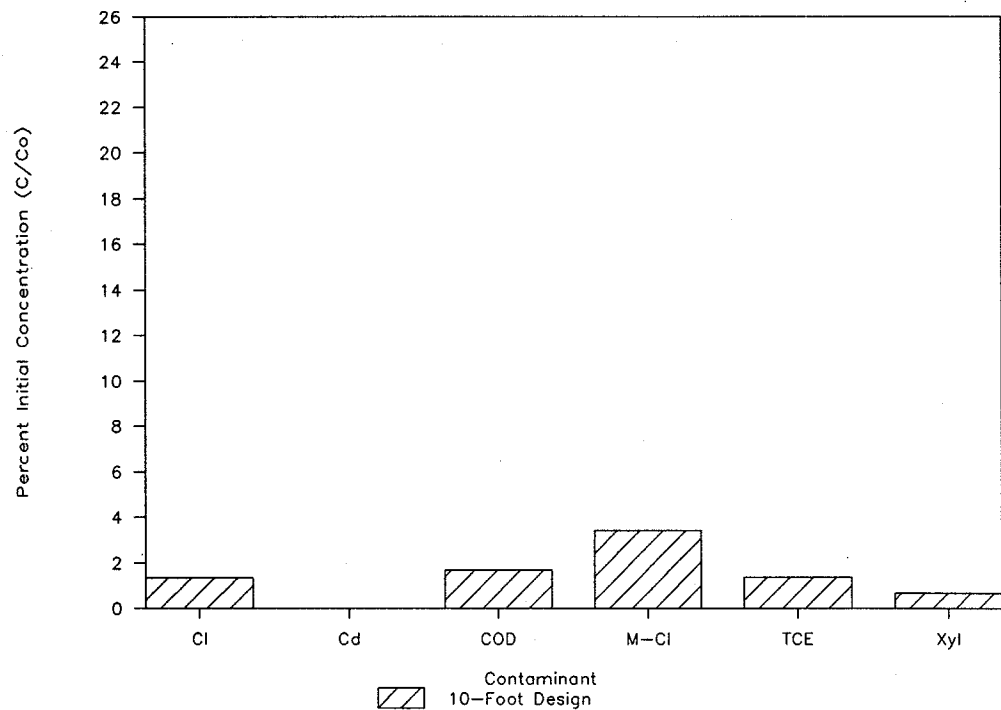

Figure 17 Maximum concentrations of contaminants 100 feet from the landfill source area of the B scenario predicted by PLASM/Random Walk (at any time during 100-year simulation).

Table 11 Comparison of confining layer thickness for the 10-foot and 3-foot landfill liner designs of the C1, C2b, C4, and C5 scenarios.

Design	10-foot liner no leachate collection	3-foot liner leachate collection
Liner thickness (feet)	10	3
Thickness of confining layer (feet)	+15	+15
Total thickness of confining layer	25	18

shows the predicted contaminant concentrations 100 feet from the source area for the sand aquifer.

The results of this simulation indicate that migration of contaminants past IPCB's proposed 100-foot compliance distance is possible for a landfill site similar to the B scenario. Because of loss of particles to the lower layers, predicted migration rates and concentrations 100 feet from the source area were not as high as for other scenarios with equally transmissive aquifers. Based on these results, potential for groundwater contamination may be high to moderate from land disposal site in a hydrogeologic sequence similar to the B scenario.

C1 Scenario

The conceptual model for the C1 scenario was 35 feet of clay-rich diamicton overlying 15 feet of highly fractured limestone or dolomite. This model was similar to that of the A1 scenario, but its diamicton unit was thicker; thus there was a confining layer between the landfill and the aquifer.

Predicted contaminant migration of chloride, COD, and methylene chloride (all highly mobile) was extensive for the 10-foot landfill liner design (fig. 18). For the 3-foot design, predicted migration of the highly mobile contaminants, as well as TCE and xylene (moderate to low mobility), was extensive (fig. 18). For all contaminants, the predicted extent of migration was less for the simulations incorporating the 10-foot liner design. This difference was due to the longer travel time of the particle through the simulated 10-foot liner and underlying confining layer (table 11).

Overall, migration rates predicted for the C1 scenario were high because 1) the lower layer, representing a fractured carbonate aquifer, had high hydraulic conductivity and low porosity, and 2) retardation factors for the fractured limestone were lower than for materials such as clay and shale. Figure 19 shows the peak concentrations predicted for contaminants 100 feet from the source area.

The PLASM/Random Walk predictions of chloride concentration and migration for the 10-foot liner design were tested with MOC. Table 12 shows the test results. The PLUME model was not used for this test because it cannot solve for layered hydrogeologic units.

According to the results of the PLASM/Random Walk and MOC simulations, leakage from a land disposal site with hydrogeologic conditions similar to those modeled for the C1 scenario could degrade groundwater quality. Less mobile contaminants would likely be subject to attenuation in the confining layer; however, contaminants of high mobility could possibly seep through to the underlying aquifer where the high hydraulic conductivity would allow rapid migration. The potential for groundwater contamination resulting from land disposal of wastes at sites with hydrogeologic sequences similar to the C1 scenario may be high to moderate, depending on the mobility of the contaminants.

C2 Scenario

The conceptual model used for the C2 scenario was 30 feet of clay-rich diamicton overlying 10 feet of sand or highly permeable sandstone. The sand/sandstone aquifer was separated from the landfill by a 10-foot-thick confining layer.

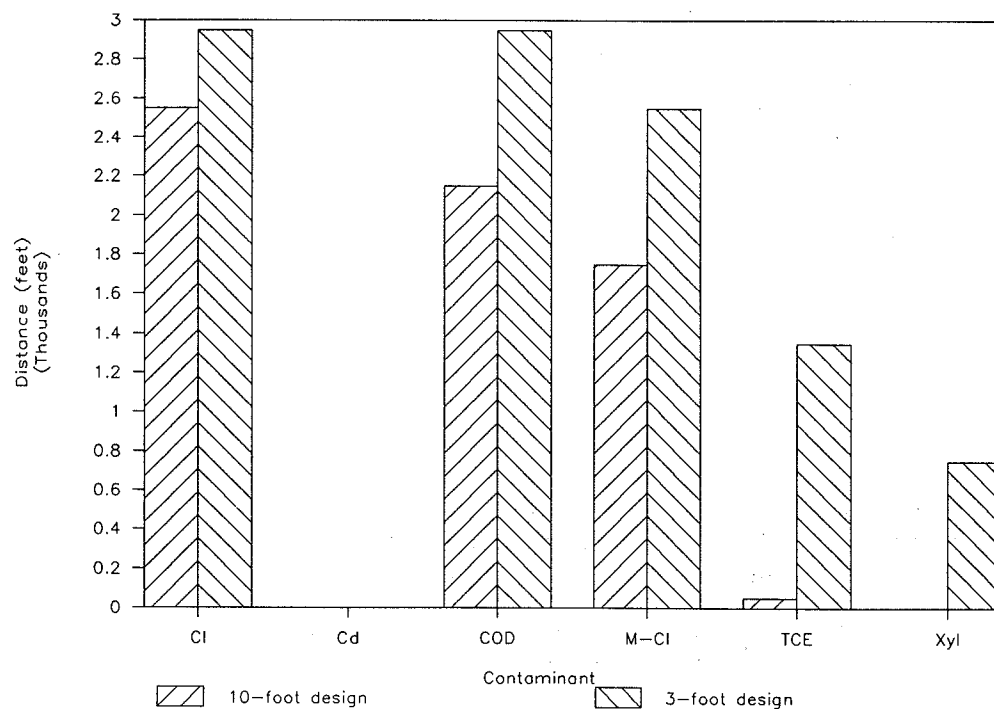

Figure 18 Maximum extent of contaminant migration predicted for the C1 scenario by PLASM/Random Walk (simulated time = 100 years).

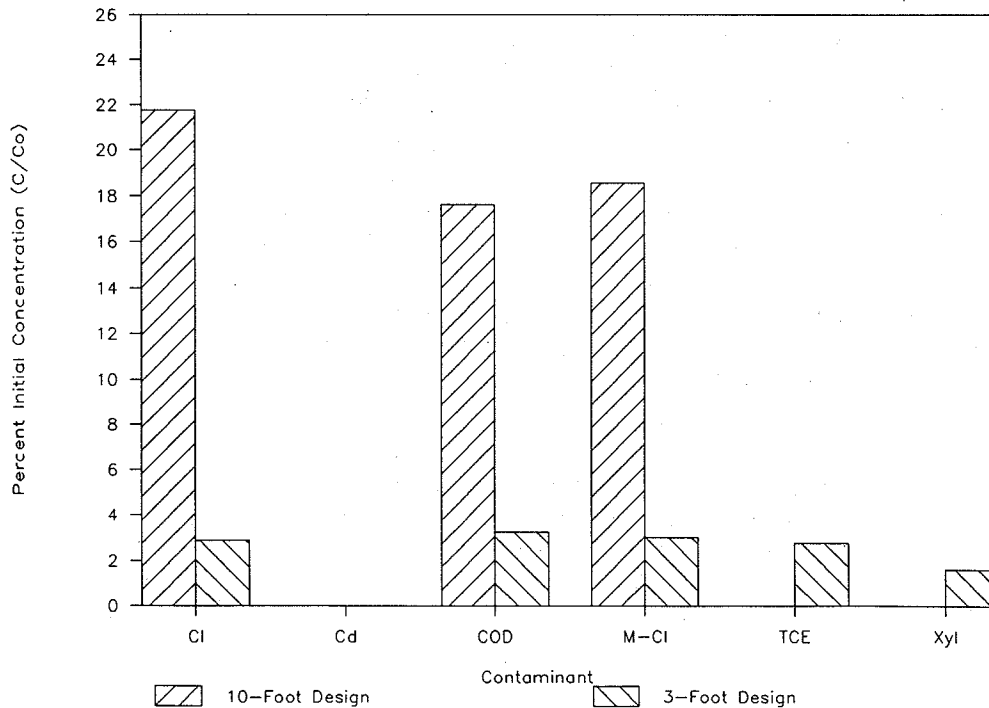

Figure 19 Maximum concentrations of contaminants 100 feet from the landfill source area of the C1 scenario predicted by PLASM/Random Walk (at any time during 100-year simulation).

Table 12 Comparison of PLASM/Random Walk results to PLUME and MOC results for chloride, C1 scenario, 10-foot liner design. Horizontal node spacing was 100 feet for MOCa and 500 feet for MOCb simulations.

Time (years)	Chloride plume extent (feet)			Chloride concentration 100 feet from source area (ppm)	
	PLASM	MOCa	MOCb	PLASM	MOCa
10	100	50	0	4	10
20	400	450	500	18	117
30	650	750	1000	215	295
40	1100	***	1000	653	397
50	1350	***	1500	537	429
60	1350	***	1500	617	398
70	1750	***	2000	492	356
80	2150	***	2000	322	302
90	2150	***	2500	304	251
100	2550	***	3000	188	206

*** migration past grid boundary (1100 feet from simulated landfill)

Predicted particle migration of this scenario was more extensive for the 3-foot design than for the 10-foot design (fig. 20). This difference was due to greater travel time for particles through the thicker liner simulated with the 10-foot design (table 11). The difference was most notable for the moderate to low mobility contaminants (trichloroethylene and xylene). Overall, extensive migration was predicted for this scenario because 1) the thickness of the confining layer (between the landfill nodes and the aquifer) was not sufficient to prevent particles from reaching the aquifer, 2) the sand aquifer was represented by a layer of relatively high hydraulic conductivity, and 3) retardation values for the sand were low. Figure 21 shows predicted contaminant concentrations 100 feet from the source area in the sand aquifer.

The PLASM/Random Walk predictions of chloride concentration and migration for the 10-foot liner design of the C2 scenario were tested with MOC. Table 13 shows the results of that test.

Retardation in the confining layer of the C2 scenario limited the migration of the less mobile contaminants; however, the highly mobile contaminants of this scenario were not significantly retarded (example: chloride particles reached the sand layer during the first 5-year time step for both the A2 and C2 scenarios, see appendix A). A site with hydrogeologic characteristics similar to the C2 scenario may have a high to moderate potential for groundwater contamination from land burial of wastes.

C2b Scenario

The conceptual model for the C2b scenario was 35 feet of sandy diamicton overlying 15 feet of sand or sandstone with high hydraulic conductivity. The confining layer of this scenario was thicker (35 feet of sandy diamicton - 20 feet for landfill excavation = 15 feet of confining material), but more permeable than that of the C2 scenario.

Predicted contaminant migration for the C2b scenario (fig. 22) was more extensive than for the C2 scenario because the simulated confining layer had higher hydraulic conductivity, which caused particles to reach the aquifer more quickly (the hydraulic conductivity of the confining layer was one order of magnitude higher than for the C2 scenario). This difference of one order of magnitude more than compensated for the increased travel time through the thicker 15-foot confining layer of the C2b scenario (as opposed to the 10-foot confining layer used for the C2 scenario). Figure 23 shows the predicted contaminant concentrations.

The PLASM/Random Walk predictions of chloride concentration and migration for the 10-foot design of the C2b scenario were tested with MOC. Table 14 shows the results.

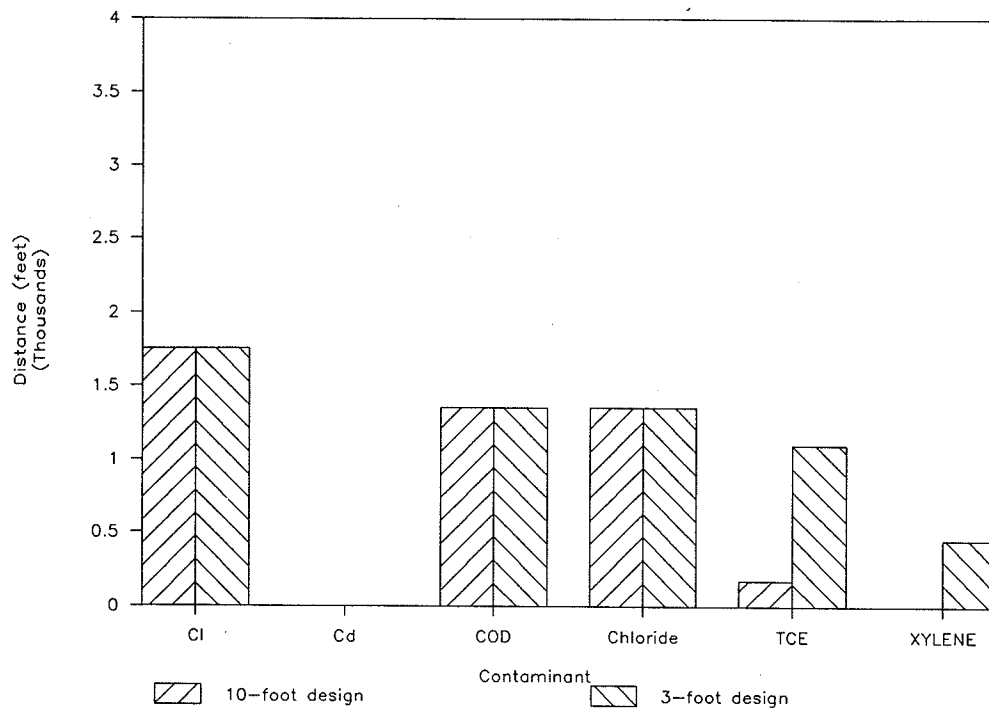

Figure 20 Maximum extent of contaminant migration predicted for the C2 scenario by PLASM/Random Walk (simulated time = 100 years).

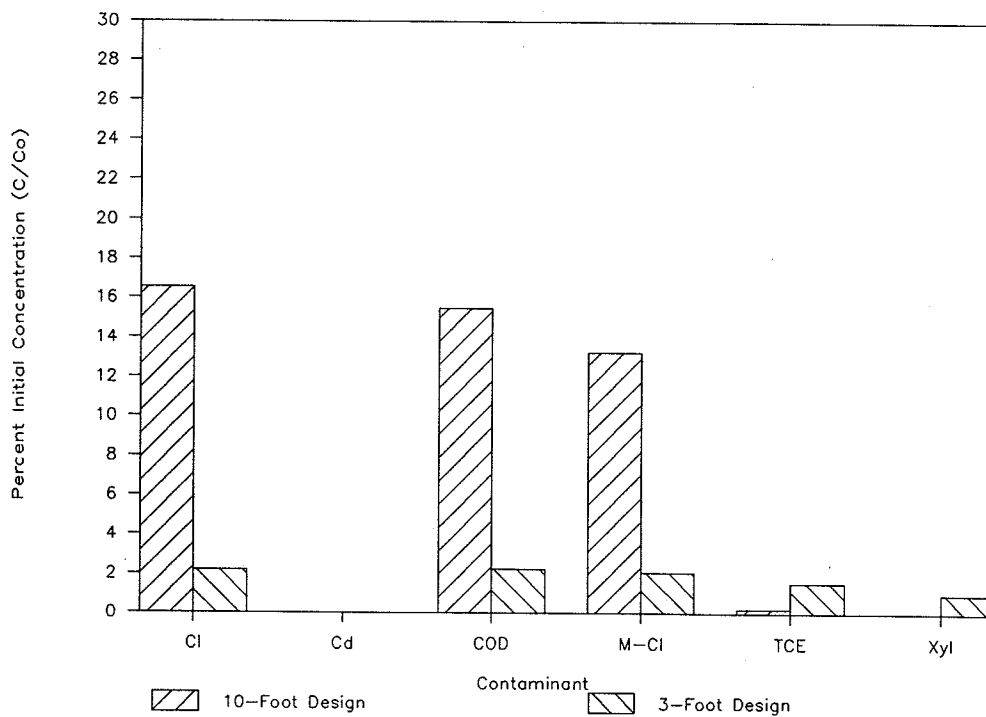

Figure 21 Maximum concentrations of contaminants 100 feet from the landfill source area of the C2 scenario predicted by PLASM/Random Walk (at any time during 100-year simulation).

Table 13 Comparison of PLASM/Random Walk results to PLUME and MOC results for chloride, C2 scenario, 10-foot liner design. Horizontal node spacing was 100 feet for MOCa and 250 feet for MOCb simulations.

Time (years)	Chloride plume extent (feet)			Chloride concentration 100 feet from source area (ppm)	
	PLASM	MOCa	MOCb	PLASM	MOCa
10	25	50	0	0	0
20	300	350	500	13	150
30	450	550	500	114	313
40	650	750	750	215	568
50	850	850	1000	436	608
60	950	1050	1250	469	591
70	1100	***	1250	496	548
80	1350	***	1500	382	479
90	1750	***	1750	335	410
100	1750	***	2000	262	348

*** migration past grid boundary (1100 feet from simulated landfill)

Table 14 Comparison of PLASM/Random Walk results to PLUME and MOC results for chloride, C2b scenario, 10-foot liner design. Horizontal node spacing was 100 feet for MOCa and 250 feet for MOCb simulations.

Time (years)	Chloride plume extent (feet)			Chloride concentration 100 feet from source area (ppm)	
	PLASM	MOCa	MOCb	PLASM	MOCa
10	100	150	0	13	51
20	350	350	250	152	337
30	650	650	750	402	502
40	850	850	750	680	513
50	1100	1050	1000	827	446
60	1100	***	1250	532	365
70	1350	***	1500	268	277
80	1750	***	1750	89	211
90	1750	***	2000	27	159
100	2150	***	2000	0	118

*** migration past grid boundary (100 feet from simulated landfill)

The results of the C2b scenario show that the hydraulic conductivity of the confining layer is at least as important as its thickness. For the C2 scenario, a confining layer 10 feet thick with hydraulic conductivity of 1×10^{-7} cm/s was simulated; for this scenario the confining layer was 15 feet thick and hydraulic conductivity, 1×10^{-6} cm/s. The migration distances of contaminants for the C2b scenario were greater than those for the C2 scenario, even though the thickness of the confining layer was greater. From the extensive migration predicted for the C2b scenario, the conclusion is that an area with similar hydrogeologic characteristics may have a high to moderate potential for groundwater contamination resulting from land burial of wastes.

C4 Scenario

The conceptual model used for the C4 scenario was 35 feet of clay-rich diamicton overlying 15 feet of cemented sandstone. This model was similar to that of the A4 scenario; however, a confining layer, 15 feet in thickness, separated the landfill from the low-yield aquifer.

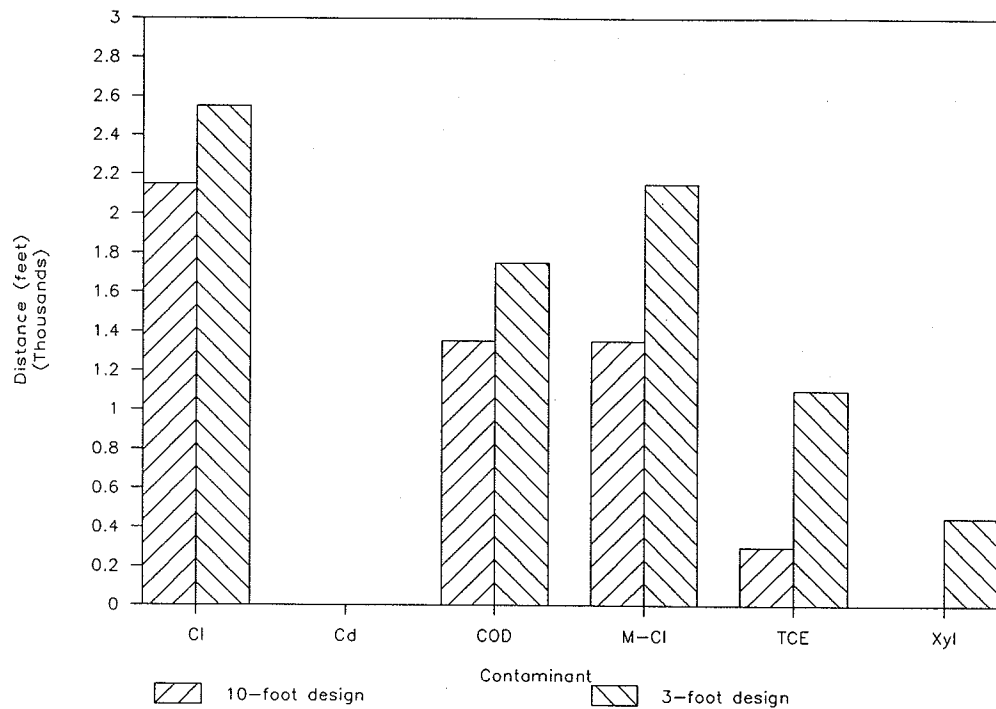

Figure 22 Maximum extent of contaminant migration predicted for the C2b scenario by PLASM/Random Walk (simulated time = 100 years).

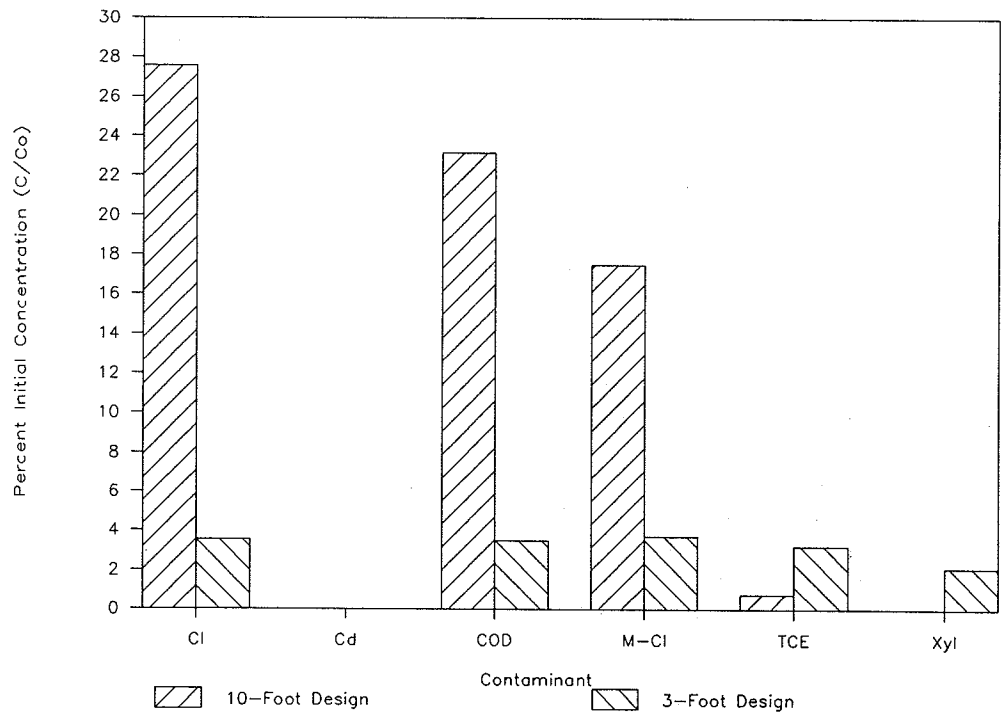

Figure 23 Maximum concentrations of contaminants 100 feet from the landfill source area of the C2b scenario predicted by PLASM/Random Walk (at any time during 100-year simulation).

Table 15 Comparison of PLASM/Random Walk results to MOC results for chloride, C4 scenario, 10-foot liner design.

Time (years)	Chloride plume extent (feet)		Chloride concentration 100 feet from source area (ppm)	
	PLASM	MOC	PLASM	MOC
10	0	0	0	0
20	0	0	0	0
30	0	0	0	0
40	0	1	0	0
50	1	1	0	0
60	25	1	0	0
70	25	1	0	0
80	25	50	0	0
90	25	50	0	0
100	25	50	0	0

Only chloride, modeled for the 3-foot liner design, had predicted migration beyond the proposed 100-foot compliance distance (fig. 24). The chloride concentration 100 feet from the landfill was slightly more than 2 ppm (parts per million) after 100 years (see appendix A). Little migration was predicted for this scenario because 1) the hydraulic conductivity of the confining layer was sufficiently low to delay particle entry to the aquifer and 2) the moderate hydraulic conductivity used for the aquifer restricted particle transport. However, as in the A4b scenario, an increase in hydraulic conductivity by one order of magnitude would probably allow the contaminants with highest mobility (chloride, COD, and methylene chloride) to migrate past the proposed 100-foot compliance distance. Figure 25 shows the chloride plume in the simulated aquifer (layer 3 of the model). Note that the center of mass is still beneath the source area. With time it is likely that these contaminants could reach the IPCB-proposed compliance distance 100 feet from the edge of the source area.

The PLASM/Random Walk predictions of chloride concentration and migration for the 10-foot liner design of this scenario were tested with MOC. Table 15 shows the results.

Little contamination was predicted at the proposed compliance distance for this scenario, despite the conservative conditions of the water table at the base of the simulated landfill and strong vertical gradients through the confining layer. Contamination, however, was predicted in the aquifer (lowermost layer) directly below the source area, and some particle migration beyond the boundary of the source area occurred. Therefore, it is likely that contaminants will eventually reach the IPCB-proposed compliance distance. Furthermore, if the simulated hydrogeology were less restrictive to particle migration (such as higher hydraulic conductivity, as used for the A4b scenario), the highly mobile particles (representing chloride, COD, and methylene chloride) probably would have migrated past the proposed 100-foot compliance distance during the 100-year simulation period. The potential for groundwater contamination due to land disposal of wastes at a site such as represented by the C4 scenario appears to be moderate.

C5 Scenario

The C5 scenario was the most complex sequence attempted during these simulations. Only results from the 10-foot liner design of this scenario are presented. Acceptable convergence could not be reached when modeling this scenario with a 3-foot liner design. The conceptual model was 50 feet of diamicton with discontinuous sand lenses. The sand lens may represent an aquifer of limited areal extent. The uppermost layers of the PLASM/Random Walk grid were set to represent the clay unit and particle source area (landfill); layer 3 represented clay with a discontinuous sand lens.

Figure 26 shows the steady-state hydraulic head for layer 3. Mounding is apparent beneath the source area at nodes representing clay; however, no mounding was predicted at the nodes repre-

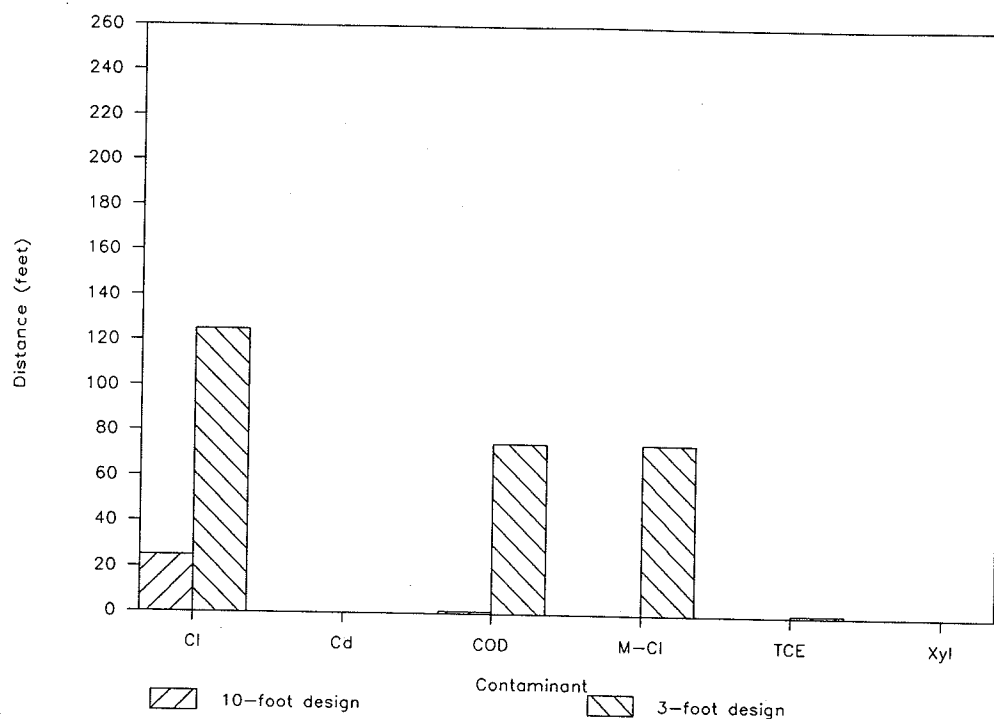

Figure 24 Maximum extent of contaminant migration predicted for the C4 scenario by PLASM/Random Walk (simulated time = 100 years).

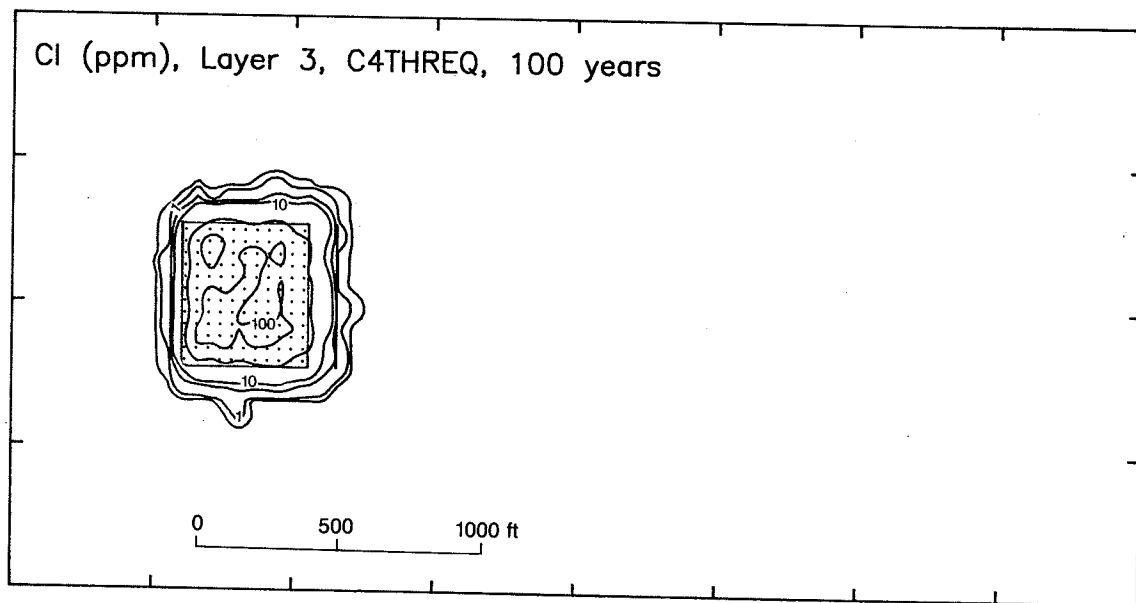

Figure 25 Chloride plume in layer 3 (cemented sandstone aquifer) of the C4 scenario, as predicted by PLASM/Random Walk. Note that center of mass is beneath landfill area.

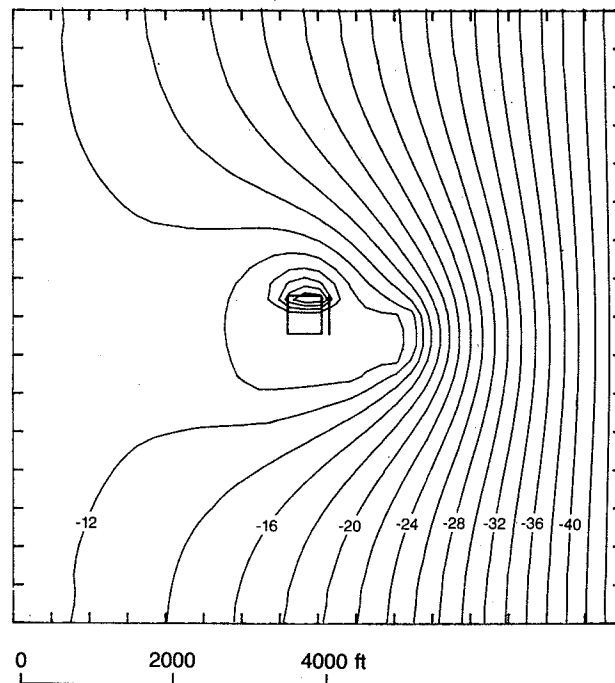

Figure 26 Steady-state head distribution predicted for the C5 scenario by PLASM. Note mound beneath portion of landfill overlying materials with low hydraulic conductivity. Simulated sand lens (high hydraulic conductivity) is shown by area of no gradient in lower center of plot.

senting the sand lens. There was little change of hydraulic head throughout the sand lens; thus horizontal gradients are low.

Predicted migration for chloride in the sand lens was 100 feet in 100 years; none of the other contaminants had observable particle migration. Little contaminant migration occurred for this scenario because the gradient in the sand lens was low, and the hydraulic conductivity of the clay-rich materials around the sand lens was low.

The C5 scenario could not be tested with PLUME or MOC. The hydrogeology of this scenario was too complex to be simulated with those codes.

The simulation results for the C5 scenario indicated that it was possible for contaminants at such a site to migrate to the IPCB-proposed compliance distance in 100 years. The extent of the migration will depend on many factors, including 1) the extent and continuity of the sand lenses, 2) the depth of the sand lenses, 3) the hydrogeologic properties of the sand lenses, 4) the hydrogeologic properties of the surrounding materials, and 5) the effects of man on the hydraulic head of the aquifer. If a pumping well had been introduced to the sand lens, a gradient could have been created and contaminant migration would have been more extensive. The potential for contamination of groundwater due to land disposal of wastes at a site with hydrogeological characteristics similar to the C5 scenario may be low to moderate. With changed conditions, such as an extensive sand lens at the base of the landfill or hydraulic connection between the sand lens and a groundwater sink (i.e., well, lake, river), it is conceivable that this potential would be increased.

C5b Scenario

The conceptual model for the C5b scenario was 35 feet of silt overlying 15 feet of clay-rich diamicton. The silt unit may represent a very low-yield aquifer.

Particles did not migrate more than 25 feet in the simulation. Little migration was predicted by the PLASM/Random Walk model for this scenario because 1) the hydraulic conductivity of the silt was low, particularly in comparison to the sandy aquifers described previously, and 2) the

Table 16 Comparison of PLASM/Random Walk results to PLUME and MOC results for chloride, C5b scenario, 10-foot liner design.

Time (years)	Chloride plume extent (feet)		
	PLASM	PLUME	MOC
10	0		1
20	1		1
30	1		1
40	1		1
50	25		50
60	25		50
70	25		50
80	25		50
90	25		50
100	25	60	50

Table 17 Comparison of PLASM/Random Walk results to PLUME and MOC results for chloride, D scenario, 10-foot liner design.

Time (years)	Chloride plume extent (feet)		
	PLASM	PLUME	MOC
10	0		1
20	1		1
30	1		1
40	1		1
50	25		1
60	25		1
70	25		50
80	25		50
90	25		50
100	25	20	50

porosity of the silt was high. These two factors caused relatively low advection rates and, hence, limited migration.

The PLASM/Random Walk predictions of chloride migration for the 10-foot liner design of this scenario were tested with PLUME and MOC. Table 16 shows the results.

No contamination was predicted at the IPCB-proposed 100-foot compliance distance during the simulated 100-year interval. Contamination was predicted in the silt unit, however, and particles migrated past the boundary of the source. It is likely that with very long simulation times (greater than 100 years), contamination could reach the proposed compliance distance. The potential for groundwater contamination resulting from land disposal of wastes at a site with hydrogeology similar to that modeled for the C5b scenario is predicted to be low to moderate.

D Scenario

The conceptual model for the D scenario was 50 feet of sandy loam. No aquifer was present; however, water is obtained from such materials by use of large-diameter cistern wells in some areas of Illinois.

The predicted maximum extent of particle migration was 25 feet. The PLASM/Random Walk model predicted little migration for this scenario because the hydraulic conductivity of the sandy loam material was relatively low.

The PLASM/Random Walk predictions of chloride migration for the 10-foot liner design of this scenario were tested with PLUME and MOC. Table 17 shows the test results.

No contamination was predicted at the proposed 100-foot compliance distance during the 100-year simulation. Contamination was predicted in the material below the source area (landfill), and migration beyond the boundary of the source did occur. Therefore, it is possible that contamination could eventually reach the proposed compliance distance. Migration at a site that might appear to be similar to this scenario could also be enhanced by non-homogeneities such as thin sand seams or macropores through the diamicton. The potential for groundwater contamination resulting from land disposal of wastes at sites with hydrogeologic characteristics similar to those modeled for the D scenario may be low to moderate.

E Scenario

The conceptual model for the E scenario was 50 feet of clay-rich diamicton or other fine-grained material. No aquifer was present.

Essentially no particle migration occurred for this scenario. Only chloride, for the 10-foot liner design, migrated to the boundary of the source area. All other contaminants remained in or

Table 18 Comparison of PLASM/Random Walk results to PLUME and MOC results for chloride, E scenario, 10-foot liner design.

Time (years)	Chloride plume extent (feet)		
	PLASM	PLUME	MOC
10	0		1
20	0		1
30	0		1
40	0		1
50	0		1
60	0		1
70	0		1
80	0		1
90	0		1
100	1	0	1

Table 19 Comparison of PLASM/Random Walk results to PLUME and MOC results for chloride, F scenario, 10-foot liner design.

Time (years)	Chloride plume extent (feet)		
	PLASM	PLUME	MOC
10	0		1
20	0		1
30	0		1
40	0		1
50	0		1
60	0		1
70	0		1
80	0		1
90	0		1
100	0	0	1

beneath the source area. The low migration rates predicted for this scenario were caused by low hydraulic conductivity representative of clay-rich units.

The PLASM/Random Walk predictions of chloride migration for the 10-foot liner design of this scenario were tested with PLUME and MOC. Table 18 shows the test results.

No contamination was predicted at the proposed 100-foot compliance distance for this scenario. A few particles entered the layers beneath the source area. The potential for groundwater contamination resulting from land disposal of wastes for sites with hydrogeology similar to that of the E scenario was predicted to be low.

F Scenario

The model for the F scenario was 20 feet of clay-rich diamicton overlying nonfractured shale, limestone, or dolomite. The model did not have an aquifer.

No horizontal particle migration occurred for this scenario. Few particles migrated through the liner nodes to the nodes representing the underlying shale unit; however, the extremely low hydraulic conductivity used to represent the shale effectively prevented any appreciable migration.

The PLASM/Random Walk predictions of chloride migration for the 10-foot liner design of this scenario were tested against PLUME and MOC. Table 19 shows the test results.

Predicted migration for this scenario was lower than for any other scenario. No contamination was predicted at the proposed 100-foot compliance distance, and few particles entered the layers beneath the source area. The potential for groundwater contamination resulting from land disposal of wastes at sites with hydrogeologic characteristics similar to the F scenario was predicted to be low.

G Scenario

The model for the G scenario was 35 feet of clay-rich diamicton overlying nonfractured shale, limestone, or dolomite. No aquifer was included in this conceptual model.

Very limited particle migration was predicted. Some particles migrated through the liner nodes to the underlying nodes representing diamicton and shale. A few particles representing chloride in the diamicton migrated as far as the boundary of the source area; however, the extremely low hydraulic conductivity used to represent the shale and diamicton prevented any significant migration.

The PLASM/Random Walk predictions of chloride migration for the 10-foot liner design of this scenario were tested with MOC. Table 20 shows the results.

Table 20 Comparison of PLASM/Random Walk results to PLUME and MOC results for chloride, G scenario, 10-foot liner design.

Time (years)	Chloride plume extent (feet)	
	PLASM	MOC
10	0	1
20	0	1
30	0	1
40	0	1
50	0	1
60	0	1
70	1	1
80	1	1
90	1	1
100	1	1

No contamination was predicted at the proposed 100-foot compliance distance and few particles entered the layers beneath the source area. The potential for groundwater contamination resulting from land disposal of wastes for a site with hydrogeologic characteristics similar to those modeled for the G scenario should be low.

Ranking of Hydrogeological Scenarios

Approach

Several methods could be used to numerically rank the potential for contamination of groundwater due to land burial of wastes for the hydrogeological scenarios described in this study. One method would be to combine the concentration and migration data at specified distances from the waste disposal cell. These data could be compared to toxicity data to rate relative risk for a set of particular compounds at a particular distance. This approach, however, would be subject to arbitrary inputs such as which contaminants to evaluate and the distance of evaluation. An example of this approach is discussed on page 44. This report used a less subjective approach whereby the ranking value was based on predicted rates of contaminant migration.

Data Manipulation

Table 6 lists the maximum extent of predicted migration for each contaminant of each scenario. The data were derived from model output for concentration at each node point. Thus the maximum extent of predicted migration was the node point farthest from the landfill that had a concentration greater than 0.0. All particles in the model were assigned to the nearest node point when the final output was tabulated; therefore some scenarios have predicted migrations listed in table 6 that are slightly higher than they should be, and some scenarios have predicted migrations that are lower than they should be. To account for this rounding, Migration Ratings (MIG) were computed. The MIG uses the model output from all previous time steps to adjust the final extent of migration. Thus, if previous time steps indicate that migration for a particular contaminant of a scenario should be greater than that reported in table 6, the MIG will be adjusted higher; if previous time steps indicate that the value in table 6 should be lower, the MIG will be lower. Appendix A lists the maximum migration extent for each contaminant at the end of each time step. To calculate the Migration Rating, the following formula was used:

$$\text{MIG} = ((X_0 + X_5 + \dots + X_{50})/11) + ((X_{50} + X_{60} + \dots + X_{100})/6)$$

where:

MIG = Migration Rating

X_n = Maximum plume extent at the end of time step n

(n = 0, 5, 10, 15, ..., 45, 50, 60, ..., 90, 100)

11 = Number of 5-year time steps + 1

6 = Number of 10-year time steps + 1

Table 21 lists the calculated Migration Ratings. Comparison of table 21 with table 6 shows that the Migration Ratings accurately reflect the maximum extent of migration predicted and that the ratings give greater definition to the maximum extent of migration because migration distance data were used from all time steps, rather than only from the last time step.

These Migration Ratings were used to rank each hydrogeological scenario according to its relative potential for groundwater contamination due to land disposal of wastes. Because the six contaminants modeled for this study are only a small sample of those that may be found in contaminated groundwater, generalized categories based on mobility were used in the rating. These categories of mobility were

- conservative contaminants (chloride), which are nonadsorbed and non-degraded, and move at approximately the same velocity as groundwater
- high-mobility contaminants (methylene chloride and COD), which are subject to slight adsorption in low-clay materials and moderate adsorption in clay-rich materials
- moderate- to low-mobility contaminants (cadmium, trichloroethylene, and xylene), which are moderately adsorbed in low-clay materials and highly adsorbed in clay-rich materials.

The three categories have equal impact in the Combined Rating. By using three mobility categories, the rankings presented in this report reflect the potential migration for different possible components in a contaminant plume.

Mobility Ratings (MR) were compiled for each scenario by 1) averaging the Migration Ratings (MIG) of all contaminants grouped into each mobility category (conservative, high, low), 2) dividing by the highest Migration Rating for that category, and 3) multiplying by 1000.

MR (conservative) = MIG chloride

MR (high mobility) = (MIG COD + MIG methylene chloride)/2

MR (low mobility) = (MIG TCE + MIG xylene + MIG cadmium)/3

MR = Mobility Rating

MIG = Migration Rating

This normalization allows for a comparison of relative migration of contaminants from different categories of mobility. Tables 22a and 22b list the normalized Mobility Ratings. The Combined Rating is an average of the three Mobility Ratings. The Total Ranking (table 22c) is the average of the Combined Ratings for the two landfill designs (tables 22a and 22b).

Discussion of Results

The rankings presented in table 22c indicate the relative potential for contamination of groundwater resources, resulting from land burial of wastes, for each hydrogeological scenario modeled for this study. These rankings are based on the migration rates for contaminants in groundwater that have conservative, high, or moderate to low mobility. For descriptive purposes, the hydrogeological scenarios are grouped according to their ranking values.

Group one (total ranking greater than 100) consists of the A1, A2, A2b, A4b, B, C1, C2, and C2b scenarios. This group contains all scenarios having a continuous aquifer that is within 35 feet of ground surface and has a hydraulic conductivity of 1×10^{-4} cm/s or higher. These hydrogeological scenarios represent sand and gravel, porous sandstone, and fractured carbonate aquifers that may or may not be overlain by a thin deposit of clay-rich diamicton. Conservative and highly mobile contaminants may migrate great distances at sites with hydrogeologic conditions similar to

Table 21 Migration Ratings (MIG), calculated from the PLASM/Random Walk model predictions of plume extent at the end of each time step. A rating of 100 corresponds to a constant migration rate of 1 foot per year.
a. 10-foot liner design - no leachate collection

	Chloride	Cadmium	COD	Methylene chloride	Trichloro-ethylene	Xylene
A1	4010	0.0	3360	3200	1080	470
A2	2090	0.0	1550	1570	675	37.7
A2b	2250	0.0	1670	1730	598	12.8
A4	84.4	0.0	38.2	5.18	0.0	0.0
A4b	362	0.0	275	287	50.4	0.0
B	720	31.4	608	897	573	38
C1	2470	0.0	1870	1860	8.67	0.0
C2	1660	0.0	1230	1230	87.5	0.0
C2b	2040	0.0	1390	1370	117	0.0
C4	21.3	0.0	0.333	0.333	0.0	0.0
C5	33.8	0.0	0.0	0.0	0.0	0.0
C5b	32.2	0.0	27.8	32.2	1.45	0.833
D	34.4	0.0	17.6	1.55	0.0	0.0
E	0.167	0.0	0.0	0.0	0.0	0.0
F	0.0	0.0	0.0	0.0	0.0	0.0
G	0.667	0.0	0.0	0.0	0.0	0.0

b. 3-foot liner design - leachate collection

	Chloride	Cadmium	COD	Methylene chloride	Trichloro-ethylene	Xylene
A1	3960	9.36	3490	3300	1380	823
A2	2420	0.924	2020	1910	1050	500
A2b	2450	0.0	2000	2000	1130	490
A4	71.7	0.0	36.0	34.0	1.36	0.500
A4b	583	0.0	442	440	195	65.2
C1	3480	0.0	3130	3120	1360	756
C2	2030	0.0	1560	1600	1010	444
C2b	2630	0.0	1890	2060	1070	447
C4	82.2	0.0	42.4	42.4	0.833	0.0
C5b	1.55	0.0	1.36	1.45	0.833	0.167
D	27.8	0.0	0.500	0.0	0.0	0.0
E	0.0	0.0	0.0	0.0	0.0	0.0
F	0.0	0.0	0.0	0.0	0.0	0.0
G	0.833	0.0	0.0	0.0	0.0	0.0

Note: B and C5 scenarios were not simulated with the 3-foot liner.

those modeled for these scenarios; however, migration of contaminants with low mobility may be limited, especially at sites with confining layers. Many highly toxic contaminants, such as methylene chloride, are highly mobile for all scenarios in this group. Potential for contamination of groundwater resources due to land burial of municipal wastes at areas with geologic conditions similar to these scenarios is predicted to be moderate to high.

Group two (total ranking between 1.0 and 10) consists of the A4, C4, C5, C5b, and D hydrogeological scenarios. These scenarios represent 1) cemented sandstone that may be overlain by as much as 35 feet of clay-rich diamicton, 2) thick deposits of silty and or clayey diamicton with discontinuous sand lenses, and 3) thick deposits of sandy loam diamicton, silty loess, or silty lacustrine materials. Units made up of these materials are not commonly considered high-yield aquifers; however, small, domestic water supplies might be obtained from such materials. Maximum migration predicted for conservative contaminants in these scenarios was slightly greater

Table 22 Mobility and Combined Ratings for all hydrogeological scenarios incorporating a 10-foot liner design with no leachate collection (22a), and a 3-foot liner design with a leachate collection system (22b). Listed according to rank from highest to lowest. Values indicate relative rating and cannot be used for direct estimate of contaminant migration distance.

a. 10-foot liner design - no leachate collection

Geological scenario	Normalized mobility ratings			Combined rating
	Conservative	High	Moderate to low	
A1	1000	1000	1000	1000
A2b	562	519	394	492
A2	521	476	459	485
C1	615	568	5.58	396
B	180	229	637	349
C2b	510	421	75.2	335
C2	413	375	56.4	282
A4b	90.3	85.7	32.4	69.5
A4	21.1	6.61	0.0	9.22
C5b	8.03	9.15	1.47	6.22
D	8.58	2.91	0.0	3.83
C5	8.43	0.0	0.0	2.8
C4	5.31	0.102	0.0	1.80
G	0.166	0.0	0.0	0.055
E	0.042	0.0	0.0	0.014
F	0.0	0.0	0.0	0.000

b. 3-foot liner design - leachate collection system

Geological scenario	Normalized mobility ratings			Combined rating
	Conservative	High	Moderate to low	
A1	1000	1000	1000	1000
C1	878	921	957	918
A2b	618	588	731	646
C2b	664	582	684	643
A2	611	577	699	629
C2	458	494	632	528
A4b	147	130	117	131
C4	20.7	12.5	0.376	11.2
A4	18.1	10.3	0.841	9.74
D	7.02	0.074	0.0	2.36
C5b	0.390	0.415	0.451	0.419
G	0.210	0.0	0.0	0.070
E	0.0	0.0	0.0	0.000
F	0.0	0.0	0.0	0.000

Note: B and C5 scenarios were not simulated with the 3-foot landfill liner design.

Table 22 continued

c. total ranking values for both landfill designs for all scenarios (average of the Combined Ratings from tables 22a and 22b)

Geologic scenario	Total ranking values	Group
A1	1000	one
C1	657	one
A2b	569	one
A2	557	one
C2b	489	one
C2	405	one
B	349(a)	one
A4b	100	one
A4	9.48	two
C4	6.50	two
C5b	3.32(a)	two
D	3.10	two
C5	2.81	two
G	0.063	three
E	0.007	three
F	0.000	three

(a) Total ranking value for the B and C5 scenarios is the Combined Rating for the 10-foot landfill liner design only.

than 100 feet. Highly mobile contaminants migrated slightly less than 100 feet. Contaminants with low mobility generally did not migrate beyond the boundary of the source areas (although they were present in the layers beneath the source areas) during the 100-year time frame of these models. Potential for contamination of groundwater resources due to land burial of municipal wastes is predicted to be low to moderate for areas with geologic conditions similar to those of these scenarios. Some of these hydrogeological scenarios, particularly A4 and C4, may represent borderline situations between high and low potential for groundwater contamination. In these cases, a hydrogeologic parameter different from the one modeled, but still typical for the scenario (such as increased hydraulic conductivity, see page 25), may result in a moderate to high potential for contamination.

Group three (total ranking less than 1.0) consists of the E, F, and G scenarios. These scenarios contained no materials that would be considered aquifers, although it is possible that some of these materials could yield water to large-diameter cistern wells. These scenarios represent clay-rich materials or low permeability bedrock such as nonfractured limestone, dolomite, or shale. No contaminants migrated beyond the boundaries of the source areas for these scenarios, and only limited amounts of contaminants were observed in the layers directly beneath the source areas. Potential for contamination of groundwater resources due to land burial of municipal wastes was predicted to be low in areas with geologic conditions similar to those of these scenarios.

Alternative ranking system

The hydrogeological scenarios also were ranked according to the concentration of a particular contaminant (C) at a given distance. In such a case, the maximum concentration of the contaminant during a specified period can be compared to its maximum permissible concentration (MPC) in drinking water. Table 23 lists such a ranking system for methylene chloride and trichloroethylene. The ratio of C/MPC is used to rank potential for contamination.

Given the conservative initial concentrations used for this modeling, this alternative ranking system indicates a high potential for concentrations of methylene chloride and trichloroethylene to exceed the MPC at the IPCB-proposed compliance distance for landfills sited in areas with hydrogeology similar to that modeled for the A1, A2, A2b, B, and C2b scenarios. For the A4b, C1,

Table 23 Rankings of the hydrogeological scenarios (10-foot landfill liner design) based on concentration of methylene chloride and trichloroethylene at the IPCB-proposed 100-foot compliance distance.

Geologic scenario	Methylene chloride			Trichloroethylene		
	C/Co(max)	ppm ⁽¹⁾	C/MPC ⁽³⁾	C/Co(max)	ppm ⁽²⁾	C/MPC ⁽⁴⁾
A1	0.121	2.42	12700	0.111	0.0667	24.7
A2	0.122	2.44	12800	0.0537	0.0322	12.3
A2b	0.114	2.27	11900	0.0528	0.0317	11.7
A4	0.0		0.0	0.0		0.0
A4b	0.0925	1.85	9740	0.00083	0.00050	0.185
B	0.0341	0.682	3590	0.0137	0.00822	3.04
C1	0.186	3.71	19500	0.0		0.0
C2	0.133	2.65	13900	0.00223	0.00134	0.496
C2b	0.175	3.50	18400	0.00745	0.00447	1.66
C4	0.0		0.0	0.0		0.0
C5	0.0		0.0	0.0		0.0
C5b	0.0		0.0	0.0		0.0
D	0.0		0.0	0.0		0.0
E	0.0		0.0	0.0		0.0
F	0.0		0.0	0.0		0.0
G	0.0		0.0	0.0		0.0

Note: C/Co is the ratio of calculated concentration 100 feet from the source area (C) to initial concentration in the source area (Co); C/MPC is the ratio of calculated concentration (C) to maximum permissible concentration (MPC). C/MPC greater than 1.0 indicates calculated concentrations at the 100-foot compliance distance in excess of the MPC (**bold**).

(1) Maximum concentration (in ppm) of methylene chloride is 100 feet from the source area compliance line, assuming an initial concentration of 20.0 ppm.

(2) Maximum concentration (in ppm) of trichloroethylene is 100 feet from the source area, assuming an initial concentration of 0.150 ppm.

(3) MPC for methylene chloride is 1.9×10^{-4} ppm (George, 1987).

(4) MPC for trichloroethylene is 2.7×10^{-3} ppm (George, 1987).

and C2 scenarios, methylene chloride concentrations may exceed the MPC at the compliance distance, but trichloroethylene concentrations will probably not exceed the MPC within 100 years.

The data in table 23 can also be used in a reverse calculation to determine the amount of contaminant that could be permitted in a landfill without exceeding the MPC at some point downgradient (after the method of Griffin and Roy, 1986). In the C1 scenario, for example, C/Co for methylene chloride 100 feet from the source area is 0.186; MPC is 0.19 ppb (parts per billion). The initial concentration of methylene chloride in the landfill for this scenario, therefore, would have to be less than 1.02 ppb ($0.19/0.186 = 1.02$) to avoid exceeding the MPC at the 100-foot compliance distance. Because trichloroethylene did not migrate to that distance during the 100-year interval of the modeling, the initial concentration of that contaminant is not an issue for this scenario. Thus, for a landfill sited in an area similar to that represented by the C1 hydrogeological scenario, methylene chloride would be a critical contaminant, and should be carefully monitored.

SUMMARY AND CONCLUSIONS

The results of this project are based on numerical approximations of contaminant transport for the 16 modeled hydrogeological scenarios, and subject to the assumptions inherent to those models.

The assumptions used in this assessment were for a worst-case scenario of seepage through the liner. This assessment may be used only for comparison of relative migration for hydrogeologic conditions similar to those assumptions. For example, the assumption of the water table at the base of the liner was used to cause contaminant migration for scenarios with the 3-foot liner design. The more typical case in Illinois may be a water table above the bottom liner, in which

Table 24 Hydrogeological scenarios for which contaminants from a simulated landfill do not migrate past given compliance distances within 100 years. Based on migration distances listed in table 6.

	Compliance distance (feet)							
	50	100	150	200	300	400	500	1000
Scenarios in compliance after 100 years of simulation	C5b	C5b	A4	A4	A4	A4	A4	A4
	D	D	C4	C4	C4	C4	C4	A4b
	E	E	C5	C5	C5	C5	C5	B
	F	F	C5b	C5b	C5b	C5b	C5b	C4
	G	G	D	D	D	D	D	C5
			E	E	E	E	E	C5b
			F	F	F	F	F	D
		G	G	G	G	G	E	
							F	
							G	

case groundwater flow would be into the landfill, and contaminant migration probably would be very limited.

The Illinois Pollution Control Board has proposed that the compliance distance around all new sanitary landfills be set at 100 feet. Migration of contaminants may not occur outside of this distance during a 100-year span. Table 24 lists the scenarios for which predicted migration did not exceed specified compliance distances during the 100-year simulation. These compliance distances ranged from 50 to 1000 feet, and include the IPCB recommendation of 100 feet.

For example, predicted migration of all six contaminants modeled for the C5b, D, E, F, and G scenarios was less than 50 feet in 100 years. Migration at these scenarios, therefore, does not exceed a compliance distance of 50 feet or more. All other scenarios modeled for this exercise had predicted migration in excess of a 100-foot compliance distance. The listing of scenarios for the compliance distances in table 24 is based on the contaminant with the greatest predicted migration for either landfill design. For example, predicted migration for all contaminants simulated for both designs of the C5b scenario was less than 50 feet. If predicted migration for one contaminant in this scenario had been 125 feet, rather than 25 feet, even if only for one of the two designs, the C5b scenario would not have been listed for compliance distances greater than 50 feet. Rather, it would have been listed for compliance distances greater than 150 feet. These results indicate that a compliance distance of 100 feet or less may limit areas where landfills can be sited; whereas a compliance distance of 150 to 500 feet will allow more tolerance in site selection.

Predicted migration for the C5b, D, E, F, and G scenarios did not exceed the IPCB-proposed compliance distance of 100 feet during the 100-year simulations. These scenarios also would have been in compliance if the distance were 50 rather than 100 feet. None of these scenarios contained layers representing continuous aquifers. If the compliance distance was expanded to 150 feet, predictions indicate that the A4, C4, C5, and C5b scenarios also would be in compliance after 100 years. The A4 and C4 scenarios contained continuous, low-yield aquifers.

If initial landfill siting is based on the probability of contaminants migrating beyond the compliance distance, it would be possible, given a 150- to 500-foot compliance distance, to site a landfill over a low-yield aquifer similar to those represented in the A4 and C4 scenarios. This situation would be less likely with a compliance distance of 100 feet. These results indicate that the 100-foot compliance distance proposed by the IPCB would be more protective of groundwater in aquifers than a larger compliance distance.

Two landfill designs were incorporated into the simulations: a 10-foot-thick landfill liner without leachate collection and a 3-foot-thick liner with a leachate collection system. Simulations incorporating the 3-foot liner design generally had slightly higher migration rates because the leakance

values used to represent the 3-foot liner were greater than those of the 10-foot liner (see page 12).

Concentrations of relatively mobile contaminants in the layers beneath the source area generally were lower for simulations incorporating the 3-foot design than for those with the 10-foot design. These lower concentrations were due to the lower initial mass of contaminants used to simulate the effects of the leachate collection system in the 3-foot design. Relatively immobile contaminants were subject to greater attenuation while migrating through the 10-foot liner. Therefore, concentrations of relatively immobile contaminants simulated with the 10-foot liner design were often lower than concentrations of the same contaminants simulated with the 3-foot liner design.

The confining layer used in the C scenarios did not stop particles representing mobile contaminants from reaching the underlying layer of high hydraulic conductivity. The overall effect of this confining layer was increased vertical dispersion of contaminants, which delayed migration to the underlying layer. Low mobility contaminants, particularly xylene, were completely attenuated within this confining layer for some of the C scenarios.

Berg, Kempton, and Cartwright (1984) ranked the potential for groundwater contamination for hypothetical landfills at 18 geologic sequences based on the hydrogeologic and attenuative properties of the upper 50 feet of geologic materials (fig. 1). They gave greatest weight to the hydrogeologic properties of the confining materials overlying the aquifer. The modeling performed for this research project suggests that the hydrogeologic properties of the aquifer are at least equally important when assessing potential for contamination, particularly because many landfill trenches penetrate the confining layer, leaving only 10 to 20 feet of material between the landfill and the aquifer.

The predicted migration distances (table 6) indicate that several sequences, mapped by Berg, Kempton, and Cartwright as having moderate potential for groundwater contamination, may be subject to as much or more contaminant migration as those sequences they mapped as having high potential for contamination. This model, however, predicted minimal contaminant migration for those sequences they mapped as having low potential for groundwater contamination, thereby validating their assessments of areas having a low potential for groundwater contamination resulting from land burial of municipal wastes.

Based on the migration distances predicted for chloride, cadmium, COD, methylene chloride, TCE, and xylene, and the assumptions and initial conditions of the mathematical and conceptual models used for this study, the following conclusions were made regarding the suitability of certain geologic sequences as sites for sanitary landfill disposal facilities:

- Siting a municipal waste disposal facility would be difficult without posing a high potential for contamination in areas where a continuous aquifer has hydraulic conductivity greater than 1×10^{-4} cm/s and is within 35 feet of the ground surface. Predicted migration of all modeled chemical constituents, except cadmium, was extensive for hydrogeological scenarios representing these areas. For example, predicted migration of methylene chloride was greater than 500 feet for scenarios with these simulated hydrogeologic conditions. This conclusion does not imply that an aquifer overlain by thicker confining layers will have a low probability of contamination, since such a scenario was not tested.
- Siting a municipal waste disposal facility may be possible without posing a high potential for contamination in areas that contain 1) cemented sandstone that may be overlain by as much as 35 feet of clay-rich diamicton, 2) thick deposits of silty and/or clayey diamicton with discontinuous sand lenses, and 3) thick deposits of sandy loam diamicton, silt-rich loess, or silt-rich lacustrine materials. This conclusion assumes 1) the landfill is carefully designed to minimize leakage, and 2) underlying materials have no pathways of preferential flow (i.e., joints, fractures) that would allow rapid migration of contaminants. Predicted migration of contaminants with conservative to high mobility was

limited for hydrogeological scenarios representing these areas. Little migration was predicted for contaminants with moderate to low mobility.

- The lowest potential for groundwater resource contamination will occur in areas where the uppermost 50 feet of geologic material contains no aquifers and consists of clay-rich diamicton or low-permeability, nonfractured bedrock. Such materials generally are not considered aquifers, and hydraulic conductivity is typically less than 1×10^{-7} cm/s. Mathematical modeling of contaminant transport for such areas predicted no appreciable contaminant migration during a simulated 100-year span.

REFERENCES

- Beljin, M.S., 1985, Analytical Modeling of Solute Transport: GWMI 85-31, International Groundwater Modeling Center, Holcomb Research Institute, Indianapolis, IN, 13 p.
- Berg, R.C., J.P. Kempton, and K. Cartwright, 1984, Potential for contamination of shallow aquifers in Illinois: Illinois State Geological Survey Circular 532, Champaign, IL, 30 p.
- Berg, R.C., J.P. Kempton, and A.N. Stecyk, 1984, Geology for planning in Boone and Winnebago Counties: Illinois State Geological Survey Circular 531, Champaign, IL, 69 p.
- Bumb, A.C., C.R. Mckee, J.M. Reverand, J.C. Halepaska, J.I. Drever, and S.C. Wey, 1984, Contaminants in groundwater--Assessment of containment and restoration options: Conference on management of uncontrolled hazardous waste sites, Hazardous Materials Control Research Institute, Washington D.C.
- Cartwright, K., 1987, Personal communication, Principal Hydrogeologist, Illinois State Geological Survey, Champaign, Illinois.
- Cartwright, K., R.H. Gilkeson, R.A. Griffin, T.M. Johnson, D.E. Lindorff, and P.B. DuMontelle, 1981, Hydrogeologic considerations in hazardous--waste disposal in Illinois: Illinois State Geological Survey Environmental Geology Notes 94, 20 p.
- Cartwright, K., and F.B. Sherman, 1969, Evaluating sanitary landfill sites in Illinois: Illinois State Geological Survey Environmental Geology Notes 27, 15 p.
- Davis, S.N., 1969, Porosity and permeability of natural materials: in DeWiest, R. J. M., ed, Flow Through Porus Media, Academic Press, New York, NY, pp. 54-86.
- Dixon, W.G., B.R. Hensel, E. Mehnert, D.F. Brutcher, and D.A. Keefer, 1986, The development of the Illinois statewide inventory of land-based disposal sites: Hazardous Waste Research and Information Center RR 10, Savoy, IL, 72 p.
- Freeze, R.A., and J.A. Cherry, 1979, Groundwater: Prentice-Hall, Inc. Englewood Cliffs, NJ, 604 p.
- Frind, E.O., and G.B. Matanga, 1985, The dual formulation of flow for contaminant transport modeling, 1. review of theory and accuracy aspects: Water Resources Research, V20, No. 2, pp. 159-169
- George, W.J., 1987, Written communication, unpublished data: Department of Pharmacology, Tulane University, New Orleans, LA.
- Griffin, R.A., and W.R. Roy, 1986, Feasibility of land disposal of organic solvents, preliminary assessment: Environmental Institute for Waste Management Studies, Report No. 10, University of Alabama, Tuscaloosa, AL, 57 p.
- Griffin, R.A., and W.R. Roy, 1987, The feasibility and limitation of land disposal of organic solvents: Environmental Institute of Waste Management Studies, Report No. 19, University of Alabama, Tuscaloosa, AL, 47 p.
- Ham, R.K., 1986, The generation and characteristics of leachate and gas from sanitary landfills: Testimony presented to the Illinois Pollution Control Board, January 17, 1986, 38 p.
- Hughes, G.M., 1972, Hydrogeologic considerations in the siting and design of landfills: Illinois State Geological Survey Environmental Geology Notes 51, 22 p.
- Illinois Pollution Control Board, 1988, Recommendations for a nonhazardous waste disposal program in Illinois and a background report to accompany proposed regulations for solid waste disposal facilities: R84-17 Docket D, unpublished report, scientific/technical section, PCB, Chicago, IL, 70 p.
- International Ground Water Modeling Center, 1987, MOC(ADI) Version 2.4: Holcomb Research Institute, Butler University, Indianapolis, IN, mathematical model code.
- Konikow, L.F., and J.D. Bredehoeft, 1978, Computer Model of Two-Dimensional Solute Transport and Dispersion in Ground Water: United States Geological Survey, Techniques of Water-Resources Investigations, Book 7, Ch C2, Reston, VA, 90 p.
- Mercer, J.W., and C.R. Faust, 1980a, Groundwater Modeling--An Overview: Groundwater, V. 18, No. 2, pp. 108-115.
- Mercer, J.W., and C.R. Faust, 1980b, Groundwater Modeling--Mathematical Models: Groundwater, V. 18, No. 3, pp. 212-227.

- Prickett, T.A., and Associates, 1984, Prickett Lonquist aquifer simulation model in three dimensions (PLASM3D) attached to Prickett, Naymik, Lonquist random walk mass transport model in three dimensions (DRAND3d): Short Course Notes, Champaign, IL, 4 p. plus appendices.
- Prickett, T.A., and Associates, 1985, Selected PLASM and random walk groundwater models for the IBM-PC desktop computer: Short Course Notes, Champaign, IL, 130 p.
- Prickett, T.A., and Associates, 1987, PLASM and DRAND3d updates of April 2, 1987: Champaign, IL, mathematical model codes.
- Prickett, T.A., and C.G. Lonquist, 1971, Selected digital computer techniques for groundwater resource evaluation: Illinois State Water Survey Bulletin 55, Champaign, IL, 62 p.
- Prickett, T.A., T.G. Naymik, and C.G. Lonquist, 1981, A "random-walk" solute transport model for selected groundwater quality evaluations: Illinois State Water Survey Bulletin 65, Champaign, IL, 103 p.
- Schmoker, J.W., K.B. Krystinik, and R.B. Halley, 1985, Selected characteristics of limestone and dolomite reservoirs in the United States: The American Association of Petroleum Geologists Bulletin, V. 69, No. 5, pp. 733-741.
- Sternberg, Y.M., 1985, Mathematical models of contaminant transport in groundwater: Environmental Institute for Waste Management Studies, Open File Report No. 4, University of Alabama, Tuscaloosa, AL, 22 p.
- Todd, D.K., 1980, Groundwater hydrology-second edition: John Wiley & Sons, Inc. New York, NY, 535 p.
- Walton, W.C., 1985, Practical aspects of groundwater modeling-second edition: National Water Well Association, Worthington, OH, 588 p.

APPENDICES

Appendix A: Tabulated Raw Data from the PLASM/Random Walk Modeling

The data presented in this appendix were tabulated directly from the output files generated by the Random Walk transport code. Two sets of data are presented: migration distance vs. simulated time, and concentration at the proposed 100-foot compliance distance vs. time. There is one table for each contaminant and each landfill design (total of 12 tables).

Chloride, 10-foot liner design.

Chloride

YEARS	DISTANCE FROM THE EDGE OF THE LANDFILL (feet)															
	0	5	10	15	20	25	30	35	40	45	50	60	70	80	90	100
A1	0	25	300	550	750	950	1100	1350	1750	2150	2150	2550	2950	2950	3450	3950
A2	0	75	150	300	400	500	600	700	850	950	1100	1350	1350	1750	1750	2150
A2B	0	50	200	300	400	500	650	750	950	1100	1100	1350	1750	1750	2150	2150
A4	0	0	0	0	0	1	1	1	25	25	50	50	75	75	100	100
A4B	0	0	50	50	75	75	125	125	150	175	175	200	250	300	350	350
B	0	0	150	225	325	425	425	425	425	425	425	425	425	425	425	425
C1	0	1	100	200	400	550	650	950	1100	1100	1350	1350	1750	2150	2150	2550
C2	0	1	25	125	300	350	450	500	650	750	850	950	1100	1350	1750	1750
C2B	0	1	100	300	350	550	650	750	850	950	1100	1100	1350	1750	1750	2150
C4	0	0	0	0	0	0	1	0	0	1	1	25	25	25	25	25
C5	0	0	0	0	0	0	0	0	0	0	1	1	25	25	50	100
C5B	0	0	0	0	1	1	1	1	25	25	25	25	25	25	25	25
D	0	0	0	0	1	1	1	25	25	25	25	25	25	25	25	25
E	0	0	0	0	0	0	0	0	0	0	0	0	0	0	0	1
F	0	0	0	0	0	0	0	0	0	0	0	0	0	0	0	0
G	0	0	0	0	0	0	0	0	0	0	0	0	1	1	1	1

Chloride

YEARS	AVERAGE CONCENTRATION AT 100 FOOT COMPLIANCE LINE (ppm)															
	0	5	10	15	20	25	30	35	40	45	50	60	70	80	90	100
A1	0	0	121	156	322	385	467	421	313	227	130	76	36	13	13	0
A2	0	0	35.7	105	188	351	463	425	380	306	241	127	85	11.2	11.2	4.47
A2B	0	0	26.8	78.2	179	306	347	428	378	363	261	114	60	26.8	15.7	0
A4	0	0	0	0	0	0	0	0	0	0	0	0	0	0	2.69	10.7
A4B	0	0	0	0	0	0	8.05	37.5	56.5	83.4	140	206	225	325	417	445
B	0	0	0	40.8	20.6	40.8	20.7	0	20.6	10.2	0	0	0	0	20.4	10.2
C1	0	0	0	26.8	17.9	62.6	215	358	653	545	537	617	492	322	304	188
C2	0	0	0	13.4	13.4	46.9	114	228	215	369	436	469	496	382	335	262
C2B	0	0	13.4	44.7	152	210	402	635	680	635	827	532	268	89.4	26.8	0
C4	0	0	0	0	0	0	0	0	0	0	0	0	0	0	0	0
C5	0	0	0	0	0	0	0	0	0	0	0	0	0	0	0	6.71
C5B	0	0	0	0	0	0	0	0	0	0	0	0	0	0	0	0
D	0	0	0	0	0	0	0	0	0	0	0	0	0	0	0	0
E	0	0	0	0	0	0	0	0	0	0	0	0	0	0	0	0
F	0	0	0	0	0	0	0	0	0	0	0	0	0	0	0	0
G	0	0	0	0	0	0	0	0	0	0	0	0	0	0	0	0

Chloride, 3-foot liner design.

Chloride

YEARS	DISTANCE FROM THE EDGE OF THE LANDFILL (feet)															
	0	5	10	15	20	25	30	35	40	45	50	60	70	80	90	100
A1	0	0	350	500	700	950	1100	1350	1750	1750	2150	2550	2950	2950	3450	3950
A2	0	25	200	350	500	600	750	850	950	1100	1350	1350	1750	1750	2150	2550
A2B	0	25	175	350	500	650	750	950	1100	1100	1350	1350	1750	2150	2150	2550
A4	0	0	0	0	1	1	1	1	1	25	25	50	50	75	100	100
A4B	0	1	50	75	150	150	175	200	250	300	300	350	450	450	500	550
C1	0	50	400	600	850	1100	1350	1350	1750	1750	1750	2150	2550	2550	2950	2950
C2	0	25	200	400	500	650	850	850	950	950	1100	1350	1350	1750	1750	2150
C2B	0	1	200	350	500	700	850	1100	1100	1350	1350	1750	1750	2150	2150	2550
C4	0	0	0	0	1	1	1	1	25	25	25	50	75	75	100	125
C5B	0	0	0	0	0	1	1	1	1	1	1	1	1	1	1	1
D	0	0	0	0	1	1	1	1	1	1	1	1	1	1	1	1
E	0	0	0	0	0	0	0	0	0	0	25	25	25	25	25	25
F	0	0	0	0	0	0	0	0	0	0	0	0	0	0	0	0
G	0	0	0	0	0	0	0	0	0	0	0	1	1	1	1	1

Chloride

YEARS	AVERAGE CONCENTRATION AT 100 FOOT COMPLIANCE LINE (ppm)															
	0	5	10	15	20	25	30	35	40	45	50	60	70	80	90	100
A1	0	0	50.1	92	78	40.7	19.2	10.3	5.37	6.26	0.313	0.894	0.447	0	0	0
A2	0	0	15.9	58.2	62.9	50.8	28.9	19.9	8.93	4.48	2.01	0.67	0.447	0.447	0.447	0.224
A2B	0	0	17.7	46.1	64.8	53.9	37.6	14.3	8.29	4.25	2.01	0.447	0.224	0	0	0
A4	0	0	0	0	0	0	0	0	0	0	0	0	0	0	0.268	0.536
A4B	0	0	0	0	1.61	3.76	9.9	24.7	31.9	36.5	49.4	51	42.7	46.1	44	30.3
C1	0	0	86.7	81.4	83.2	51.9	30.4	34.9	38.5	36.7	30.4	20.6	14.3	10.7	3.58	2.68
C2	0	0	32.2	57.7	65.7	59	65.7	65.1	61.7	47.6	40.2	38.9	21.5	20.8	8.72	4.02
C2B	0	0	25.9	104	106	96.6	87.2	51.9	25.9	13	5.37	0.894	0	0	0	0
C4	0	0	0	0	0	0	0	0	0	0	0	0	0	0	0	0
C5B	0	0	0	0	0	0	0	0	0	0	0	0	0	0	0.537	2.15
D	0	0	0	0	0	0	0	0	0	0	0	0	0	0	0	0
E	0	0	0	0	0	0	0	0	0	0	0	0	0	0	0	0
F	0	0	0	0	0	0	0	0	0	0	0	0	0	0	0	0
G	0	0	0	0	0	0	0	0	0	0	0	0	0	0	0	0

Cadmium, 10-foot liner design.

Cadmium

YEARS	DISTANCE FROM THE EDGE OF THE LANDFILL (feet)															
	0	5	10	15	20	25	30	35	40	45	50	60	70	80	90	100
A1	0	0	0	0	0	0	0	0	0	0	0	0	0	0	0	0
A2	0	0	0	0	0	0	0	0	0	0	0	0	0	0	0	0
A2B	0	0	0	0	0	0	0	0	0	0	0	0	0	0	0	0
A4	0	0	0	0	0	0	0	0	0	0	0	0	0	0	0	0
A4B	0	0	0	0	0	0	0	0	0	0	0	0	0	0	0	0
B	0	0	0	0	0	0	25	25	10	10	0	25	25	25	25	50
C1	0	0	0	0	0	0	0	0	0	0	0	0	0	0	0	0
C2	0	0	0	0	0	0	0	0	0	0	0	0	0	0	0	0
C2B	0	0	0	0	0	0	0	0	0	0	0	0	0	0	0	0
C4	0	0	0	0	0	0	0	0	0	0	0	0	0	0	0	0
C5	0	0	0	0	0	0	0	0	0	0	0	0	0	0	0	0
C5B	0	0	0	0	0	0	0	0	0	0	0	0	0	0	0	0
D	0	0	0	0	0	0	0	0	0	0	0	0	0	0	0	0
E	0	0	0	0	0	0	0	0	0	0	0	0	0	0	0	0
F	0	0	0	0	0	0	0	0	0	0	0	0	0	0	0	0
G	0	0	0	0	0	0	0	0	0	0	0	0	0	0	0	0

Cadmium

YEARS	AVERAGE CONCENTRATION AT 100 FOOT COMPLIANCE LINE (ppm)															
	0	5	10	15	20	25	30	35	40	45	50	60	70	80	90	100
A1	0	0	0	0	0	0	0	0	0	0	0	0	0	0	0	0
A2	0	0	0	0	0	0	0	0	0	0	0	0	0	0	0	0
A2B	0	0	0	0	0	0	0	0	0	0	0	0	0	0	0	0
A4	0	0	0	0	0	0	0	0	0	0	0	0	0	0	0	0
A4B	0	0	0	0	0	0	0	0	0	0	0	0	0	0	0	0
B	0	0	0	0	0	0	0	0	0	0	0	0	0	0	0	0
C1	0	0	0	0	0	0	0	0	0	0	0	0	0	0	0	0
C2	0	0	0	0	0	0	0	0	0	0	0	0	0	0	0	0
C2B	0	0	0	0	0	0	0	0	0	0	0	0	0	0	0	0
C4	0	0	0	0	0	0	0	0	0	0	0	0	0	0	0	0
C5	0	0	0	0	0	0	0	0	0	0	0	0	0	0	0	0
C5B	0	0	0	0	0	0	0	0	0	0	0	0	0	0	0	0
D	0	0	0	0	0	0	0	0	0	0	0	0	0	0	0	0
E	0	0	0	0	0	0	0	0	0	0	0	0	0	0	0	0
F	0	0	0	0	0	0	0	0	0	0	0	0	0	0	0	0
G	0	0	0	0	0	0	0	0	0	0	0	0	0	0	0	0

Cadmium, 3-foot liner design.

Cadmium

YEARS	DISTANCE FROM THE EDGE OF THE LANDFILL (feet)															
	0	5	10	15	20	25	30	35	40	45	50	60	70	80	90	100
A1	0	0	0	0	0	0	0	1	1	1	1	1	1	1	1	1
A2	0	0	0	0	0	0	0	0	0	0	0	0	0	0	0	0
A2B	0	0	0	0	0	0	0	0	0	0	0	0	0	0	0	0
A4	0	0	0	0	0	0	0	0	0	0	0	0	0	0	0	0
A4B	0	0	0	0	0	0	0	0	0	0	0	0	0	0	0	0
C1	0	0	0	0	0	0	0	0	0	0	0	0	0	0	0	0
C2	0	0	0	0	0	0	0	0	0	0	0	0	0	0	0	0
C2B	0	0	0	0	0	0	0	0	0	0	0	0	0	0	0	0
C4	0	0	0	0	0	0	0	0	0	0	0	0	0	0	0	0
C5B	0	0	0	0	0	0	0	0	0	0	0	0	0	0	0	0
D	0	0	0	0	0	0	0	0	0	0	0	0	0	0	0	0
E	0	0	0	0	0	0	0	0	0	0	0	0	0	0	0	0
F	0	0	0	0	0	0	0	0	0	0	0	0	0	0	0	0
G	0	0	0	0	0	0	0	0	0	0	0	0	0	0	0	0

Cadmium

YEARS	AVERAGE CONCENTRATION AT 100 FOOT COMPLIANCE LINE (ppm)															
	0	5	10	15	20	25	30	35	40	45	50	60	70	80	90	100
A1	0	0	0	0	0	0	0	0	0	0	0	0	0	0	0	0
A2	0	0	0	0	0	0	0	0	0	0	0	0	0	0	0	0
A2B	0	0	0	0	0	0	0	0	0	0	0	0	0	0	0	0
A4	0	0	0	0	0	0	0	0	0	0	0	0	0	0	0	0
A4B	0	0	0	0	0	0	0	0	0	0	0	0	0	0	0	0
C1	0	0	0	0	0	0	0	0	0	0	0	0	0	0	0	0
C2	0	0	0	0	0	0	0	0	0	0	0	0	0	0	0	0
C2B	0	0	0	0	0	0	0	0	0	0	0	0	0	0	0	0
C4	0	0	0	0	0	0	0	0	0	0	0	0	0	0	0	0
C5B	0	0	0	0	0	0	0	0	0	0	0	0	0	0	0	0
D	0	0	0	0	0	0	0	0	0	0	0	0	0	0	0	0
E	0	0	0	0	0	0	0	0	0	0	0	0	0	0	0	0
F	0	0	0	0	0	0	0	0	0	0	0	0	0	0	0	0
G	0	0	0	0	0	0	0	0	0	0	0	0	0	0	0	0

COD, 10-foot liner design.

COD

YEARS	DISTANCE FROM THE EDGE OF THE LANDFILL (feet)															
	0	5	10	15	20	25	30	35	40	45	50	60	70	80	90	100
A1	0	1	200	500	650	850	950	1100	1350	1350	1750	2150	2550	2550	2950	3450
A2	0	1	100	200	300	400	500	550	650	750	850	950	1100	1350	1350	1350
A2B	0	1	100	200	250	350	450	600	650	750	850	1100	1350	1350	1350	1750
A4	0	0	0	0	0	0	1	1	0	1	1	1	25	50	75	75
A4B	0	0	25	50	75	75	100	100	125	125	150	175	200	200	225	250
B	0	0	175	175	225	225	275	325	325	325	325	325	425	425	425	425
C1	0	0	0	75	300	450	550	700	850	850	950	1100	1350	1350	1750	2150
C2	0	0	0	125	225	300	400	450	550	650	650	750	750	950	1100	1350
C2B	0	0	50	150	175	300	400	500	550	650	700	850	1100	1100	1350	1350
C4	0	0	0	0	0	0	0	0	0	0	0	0	0	1	0	1
C5	0	0	0	0	0	0	0	0	0	0	0	0	0	0	0	0
C5B	0	0	0	0	1	1	1	1	1	1	25	25	25	25	25	25
D	0	0	0	0	0	1	1	1	1	1	1	1	25	25	25	25
E	0	0	0	0	0	0	0	0	0	0	0	0	0	0	0	0
F	0	0	0	0	0	0	0	0	0	0	0	0	0	0	0	0
G	0	0	0	0	0	0	0	0	0	0	0	0	0	0	0	0

COD

YEARS	AVERAGE CONCENTRATION AT 100 FOOT COMPLIANCE LINE (ppm)															
	0	5	10	15	20	25	30	35	40	45	50	60	70	80	90	100
A1	0	0	1613	3360	5914	7258	7930	10081	9812	8737	7125	6049	4570	1882	1075	807
A2	0	0	202	874	1950	4240	5920	7550	7420	10900	12300	9300	7200	4570	3290	1340
A2B	0	0	67	1076	2084	3294	5377	6654	9543	10686	10350	8737	8133	4167	3697	1882
A4	0	0	0	0	0	0	0	0	0	0	0	0	0	0	0	0
A4B	0	0	0	0	0	0	80.5	403	323	0	323	1291	1855	3065	5482	7259
B	0	0	307	0	299	0	1514	601	1223	618	311	307	0	0	618	0
C1	0	0	0	0	1075	538	538	1882	4301	2688	5377	9678	15861	13441	14517	14248
C2	0	0	0	0	403	202	807	1411	2218	3428	3428	9678	9073	10485	13912	13106
C2B	0	0	0	269	1479	2554	5377	6586	7931	10619	12904	14383	20835	20163	12500	10216
C4	0	0	0	0	0	0	0	0	0	0	0	0	0	0	0	0
C5	0	0	0	0	0	0	0	0	0	0	0	0	0	0	0	0
C5B	0	0	0	0	0	0	0	0	0	0	0	0	0	0	0	0
D	0	0	0	0	0	0	0	0	0	0	0	0	0	0	0	0
E	0	0	0	0	0	0	0	0	0	0	0	0	0	0	0	0
F	0	0	0	0	0	0	0	0	0	0	0	0	0	0	0	0
G	0	0	0	0	0	0	0	0	0	0	0	0	0	0	0	0

COD, 3-foot liner design.

COD

YEARS	DISTANCE FROM THE EDGE OF THE LANDFILL (feet)															
	0	5	10	15	20	25	30	35	40	45	50	60	70	80	90	100
A1	0	0	200	450	650	850	1100	1350	1350	1750	1750	2150	2550	2950	2950	3450
A2	0	0	125	250	400	500	600	700	750	850	950	1350	1350	1750	1750	2150
A2B	0	0	150	225	350	500	550	700	850	950	1100	1350	1350	1750	1750	2150
A4	0	0	0	0	0	0	1	1	1	1	25	25	25	50	25	50
A4B	0	0	1	25	50	100	100	150	200	225	250	300	350	350	400	400
C1	0	0	200	400	600	850	1100	1350	1350	1750	1750	2150	2550	2550	2950	2950
C2	0	0	125	300	400	450	600	700	700	750	850	950	1100	1100	1350	1350
C2B	0	0	125	200	350	450	600	650	750	850	950	1100	1350	1750	1750	2150
C4	0	0	0	0	0	1	1	1	1	1	1	1	1	1	1	1
C5B	0	0	0	0	0	0	0	0	0	0	0	1	1	0	1	0
D	0	0	0	0	0	0	0	0	0	0	0	0	0	0	0	0
E	0	0	0	0	0	0	0	0	0	0	0	0	0	0	0	0
F	0	0	0	0	0	0	0	0	0	0	0	0	0	0	0	0
G	0	0	0	0	0	0	0	0	0	0	0	0	0	0	0	0

COD

YEARS	AVERAGE CONCENTRATION AT 100 FOOT COMPLIANCE LINE (ppm)															
	0	5	10	15	20	25	30	35	40	45	50	60	70	80	90	100
A1	0	0	1129	2939	2272	1842	1035	592	417	175	80.9	80.7	0	13.5	13.5	13.5
A2	0	0	53.8	740	1519	1526	1506	1331	901	565	296	128	53.8	6.7	26.9	20.2
A2B	0	0	0	733	1559	1694	1593	1358	988	659	498	80.5	20.2	13.5	0	0
A4	0	0	0	0	0	0	0	0	0	0	0	0	0	0	0	0
A4B	0	0	0	0	0	8.05	40.4	80.5	210	540	686	1137	1484	1782	1484	1347
C1	0	0	1586	2930	2097	2043	1801	1210	1505	1102	860	1129	833	618	484	484
C2	0	0	161	988	1976	1835	2016	1815	1593	1593	1270	1230	1149	1069	625	585
C2B	0	0	26.9	1384	2635	2930	3145	2756	2352	1815	1250	309	202	94.1	67.2	0
C4	0	0	0	0	0	0	0	0	0	0	0	0	0	0	0	0
C5B	0	0	0	0	0	0	0	0	0	0	0	0	0	0	0	0
D	0	0	0	0	0	0	0	0	0	0	0	0	0	0	0	0
E	0	0	0	0	0	0	0	0	0	0	0	0	0	0	0	0
F	0	0	0	0	0	0	0	0	0	0	0	0	0	0	0	0
G	0	0	0	0	0	0	0	0	0	0	0	0	0	0	0	0

Methylene chloride, 10-foot liner design.

Methylene Chloride

YEARS	DISTANCE FROM THE EDGE OF THE LANDFILL (feet)															
	0	5	10	15	20	25	30	35	40	45	50	60	70	80	90	100
A1	0	1	200	500	600	850	950	1100	1350	1350	1750	2150	2150	2550	2950	2950
A2	0	1	150	200	300	350	450	550	550	700	750	950	1100	1350	1350	1750
A2B	0	1	100	175	250	400	500	650	700	750	850	950	1350	1350	1750	1750
A4	0	0	0	0	0	0	0	1	0	0	1	1	1	1	1	25
A4B	0	0	1	50	50	50	100	100	125	150	150	175	200	225	250	300
B	0	0	175	200	200	275	325	375	475	575	575	575	575	575	675	675
C1	0	0	1	125	250	450	550	700	700	850	950	1100	1350	1750	1750	1750
C2	0	0	0	50	100	175	250	350	550	550	700	850	950	950	1100	1350
C2B	0	0	1	125	200	300	400	450	500	600	700	850	1100	1100	1350	1350
C4	0	0	0	0	0	0	0	0	0	0	0	0	1	1	0	0
C5	0	0	0	0	0	0	0	0	0	0	0	0	0	0	0	0
C5B	0	0	0	0	1	1	1	1	25	25	25	25	25	25	25	25
D	0	0	0	0	0	1	1	1	1	1	1	1	1	1	1	1
E	0	0	0	0	0	0	0	0	0	0	0	0	0	0	0	0
F	0	0	0	0	0	0	0	0	0	0	0	0	0	0	0	0
G	0	0	0	0	0	0	0	0	0	0	0	0	0	0	0	0

Methylene Chloride

YEARS	AVERAGE CONCENTRATION AT 100 FOOT COMPLIANCE LINE (ppm)															
	0	5	10	15	20	25	30	35	40	45	50	60	70	80	90	100
A1	0	0	0.179	0.595	0.929	1.43	1.58	2.42	2.33	2.33	1.35	1.35	1.31	1.08	0.418	0.239
A2	0	0	0	0.18	0.448	0.94	1.39	1.64	1.61	2.33	2.44	2.29	1.55	1.03	0.84	0.269
A2B	0	0	0.015	0.135	0.55	0.78	1.13	1.51	2.14	2.27	2.21	1.93	1.65	1.24	0.78	0.75
A4	0	0	0	0	0	0	0	0	0	0	0	0	0	0	0	0
A4B	0	0	0	0	0	0	0.018	0.054	0.09	0.018	0.054	0.144	0.323	0.646	0.95	1.85
B	0	0	0	0.137	0.067	0.272	0.206	0.133	0.682	0	0.137	0.207	0.204	0.135	0.068	0
C1	0	0	0	0	0.0598	0.179	0.299	0.478	0.299	0.658	1.32	1.73	2.57	3.23	3.71	3.29
C2	0	0	0	0	0.135	0.0449	0.269	0.179	0.359	0.404	0.807	1.21	1.66	2.33	2.65	2.42
C2B	0	0	0	0.0598	0.329	0.538	0.867	0.807	1.405	1.974	1.914	2.751	3.319	3.499	3.259	1.914
C4	0	0	0	0	0	0	0	0	0	0	0	0	0	0	0	0
C5	0	0	0	0	0	0	0	0	0	0	0	0	0	0	0	0
C5B	0	0	0	0	0	0	0	0	0	0	0	0	0	0	0	0
D	0	0	0	0	0	0	0	0	0	0	0	0	0	0	0	0
E	0	0	0	0	0	0	0	0	0	0	0	0	0	0	0	0
F	0	0	0	0	0	0	0	0	0	0	0	0	0	0	0	0
G	0	0	0	0	0	0	0	0	0	0	0	0	0	0	0	0

Methylene chloride, 3-foot liner design.

Methylene Chloride

YEARS	DISTANCE FROM THE EDGE OF THE LANDFILL (feet)															
	0	5	10	15	20	25	30	35	40	45	50	60	70	80	90	100
A1	0	0	200	450	650	850	1100	1100	1350	1350	1750	2150	2150	2550	2950	3450
A2	0	0	125	225	400	500	600	700	750	850	950	1100	1350	1750	1750	1750
A2B	0	0	125	250	400	500	600	700	850	850	1100	1350	1350	1750	1750	1750
A4	0	0	0	0	0	0	1	1	1	1	1	25	25	50	50	50
A4B	0	0	1	50	75	125	150	150	175	200	200	225	350	400	400	450
C1	0	0	200	450	650	850	1100	1100	1350	1750	1750	2150	2150	2550	2550	2550
C2	0	0	125	225	400	450	500	600	700	750	850	1100	1100	1350	1350	1350
C2B	0	0	125	250	350	450	600	700	850	950	1100	1350	1350	1750	1750	2150
C4	0	0	0	0	0	1	1	1	1	1	1	25	50	50	50	75
C5B	0	0	0	0	0	0	1	1	1	1	1	1	1	1	1	1
D	0	0	0	0	0	0	0	0	0	0	0	0	0	0	0	0
E	0	0	0	0	0	0	0	0	0	0	0	0	0	0	0	0
F	0	0	0	0	0	0	0	0	0	0	0	0	0	0	0	0
G	0	0	0	0	0	0	0	0	0	0	0	0	0	0	0	0

Methylene Chloride

YEARS	AVERAGE CONCENTRATION AT 100 FOOT COMPLIANCE LINE (ppm)															
	0	5	10	15	20	25	30	35	40	45	50	60	70	80	90	100
A1	0	0	0.206	0.66	0.622	0.422	0.242	0.146	0.75	0.419	0.479	0.006	0.00598	0.0119	0.00899	0
A2	0	0	0.00899	0.2	0.34	0.371	0.38	0.262	0.194	0.133	0.0809	0.0209	0.012	0.00299	0.00299	0.00598
A2B	0	0	0.00598	0.155	0.335	0.411	0.361	0.295	0.202	0.161	0.066	0.0134	0	0.0015	0.0015	0
A4	0	0	0	0	0	0	0	0	0	0	0	0	0	0	0	0
A4B	0	0	0	0	0	0.0054	0.0072	0.0484	0.0824	0.122	0.206	0.256	0.334	0.35	0.334	0.326
C1	0	0	0.269	0.604	0.532	0.443	0.353	0.395	0.323	0.281	0.197	0.203	0.161	0.167	0.114	0.0538
C2	0	0	0.0359	0.242	0.274	0.377	0.417	0.413	0.39	0.314	0.301	0.215	0.265	0.224	0.179	0.166
C2B	0	0	0.0179	0.314	0.607	0.742	0.607	0.7	0.478	0.32	0.164	0.0777	0.0239	0.0209	0	0.0299
C4	0	0	0	0	0	0	0	0	0	0	0	0	0	0	0	0
C5B	0	0	0	0	0	0	0	0	0	0	0	0	0	0	0	0
D	0	0	0	0	0	0	0	0	0	0	0	0	0	0	0	0
E	0	0	0	0	0	0	0	0	0	0	0	0	0	0	0	0
F	0	0	0	0	0	0	0	0	0	0	0	0	0	0	0	0
G	0	0	0	0	0	0	0	0	0	0	0	0	0	0	0	0

Trichloroethylene, 10-foot liner design.

TCE

YEARS	DISTANCE FROM THE EDGE OF THE LANDFILL (feet)															
	0	5	10	15	20	25	30	35	40	45	50	60	70	80	90	100
A1	0	0	25	75	100	200	300	350	400	500	500	650	850	950	1100	1100
A2	0	0	1	25	75	125	150	200	200	250	350	400	500	600	700	750
A2B	0	0	0	0	1	25	75	125	200	200	225	400	500	600	700	750
A4	0	0	0	0	0	0	0	0	0	0	0	0	0	0	0	0
A4B	0	0	0	0	0	0	0	0	0	0	0	0	0	0	0	0
B	0	0	150	175	175	200	275	325	325	375	375	375	375	375	375	375
C1	0	0	0	0	0	0	0	0	0	0	0	0	0	0	0	0
C2	0	0	0	0	0	0	0	0	0	0	0	0	0	1	1	50
C2B	0	0	0	0	0	0	0	0	0	0	0	0	50	125	175	175
C4	0	0	0	0	0	0	0	0	0	0	0	25	75	100	200	300
C5	0	0	0	0	0	0	0	0	0	0	0	0	0	0	0	0
C5B	0	0	0	0	0	1	1	1	1	0	0	0	0	0	0	0
D	0	0	0	0	0	0	0	0	0	0	0	0	0	1	1	1
E	0	0	0	0	0	0	0	0	0	0	0	0	0	0	0	0
F	0	0	0	0	0	0	0	0	0	0	0	0	0	0	0	0
G	0	0	0	0	0	0	0	0	0	0	0	0	0	0	0	0

TCE

YEARS	AVERAGE CONCENTRATION AT 100 FOOT COMPLIANCE LINE (ppm)															
	0	5	10	15	20	25	30	35	40	45	50	60	70	80	90	100
A1	0	0	0	0	0.00179	0.00358	0.00504	0.0098	0.0099	0.0161	0.0268	0.0322	0.0411	0.0488	0.0606	0.0664
A2	0	0	0	0	0	0	0.00134	0.00223	0.000895	0.0058	0.00537	0.00895	0.0165	0.0259	0.0277	0.0322
A2B	0	0	0	0	0	0	0	0.00134	0.00134	0.00313	0.00224	0.0085	0.0143	0.0246	0.025	0.0317
A4	0	0	0	0	0	0	0	0	0	0	0	0	0	0	0	0
A4B	0	0	0	0	0	0	0	0	0	0	0	0	0	0	0	0
B	0	0	0	0.006	0.002	0.0041	0.004	0.002	0.0082	0.0059	0.0041	0.0082	0.0082	0.004	0.0062	0.0062
C1	0	0	0	0	0	0	0	0	0	0	0	0	0	0	0	0
C2	0	0	0	0	0	0	0	0	0	0	0	0	0	0	0	0
C2B	0	0	0	0	0	0	0	0	0	0	0	0	0	0	0	0.00134
C4	0	0	0	0	0	0	0	0	0	0	0	0	0	0.000894	0.00447	0.00179
C5	0	0	0	0	0	0	0	0	0	0	0	0	0	0	0	0
C5B	0	0	0	0	0	0	0	0	0	0	0	0	0	0	0	0
D	0	0	0	0	0	0	0	0	0	0	0	0	0	0	0	0
E	0	0	0	0	0	0	0	0	0	0	0	0	0	0	0	0
F	0	0	0	0	0	0	0	0	0	0	0	0	0	0	0	0
G	0	0	0	0	0	0	0	0	0	0	0	0	0	0	0	0

Trichloroethylene, 3-foot liner design.

TCE

YEARS	DISTANCE FROM THE EDGE OF THE LANDFILL (feet)															
	0	5	10	15	20	25	30	35	40	45	50	60	70	80	90	100
A1	0	0	50	175	250	350	450	500	550	650	700	850	950	1100	1350	1350
A2	0	0	50	125	175	225	300	350	450	500	550	650	700	850	950	1100
A2B	0	0	50	125	175	300	400	450	500	550	600	700	850	850	950	1100
A4	0	0	0	0	0	0	1	1	0	1	1	1	1	1	1	1
A4B	0	0	1	1	25	25	50	50	75	75	100	125	150	175	200	200
C1	0	0	50	175	250	400	450	500	600	650	750	850	950	1100	1100	1350
C2	0	0	25	150	200	250	300	350	400	500	550	600	650	750	950	1100
C2B	0	0	50	125	175	225	300	350	400	500	550	600	650	750	950	1100
C4	0	0	0	0	0	0	0	0	0	0	0	1	1	1	1	1
C5B	0	0	0	0	0	0	0	0	0	0	0	1	1	1	1	1
D	0	0	0	0	0	0	0	0	0	0	0	1	1	1	1	1
E	0	0	0	0	0	0	0	0	0	0	0	0	0	0	0	0
F	0	0	0	0	0	0	0	0	0	0	0	0	0	0	0	0
G	0	0	0	0	0	0	0	0	0	0	0	0	0	0	0	0

TCE

YEARS	AVERAGE CONCENTRATION AT 100 FOOT COMPLIANCE LINE (ppm)															
	0	5	10	15	20	25	30	35	40	45	50	60	70	80	90	100
A1	0	0	0	0.00134	0.00779	0.0127	0.0188	0.0216	0.0219	0.0207	0.0192	0.0142	0.00903	0.00599	0.00456	0.00223
A2	0	0	0	0.000089	0.00219	0.00537	0.00729	0.0112	0.0114	0.0115	0.0103	0.01	0.00662	0.00528	0.00246	0.00107
A2B	0	0	0	0.000134	0.00214	0.0051	0.00769	0.00935	0.0104	0.0112	0.011	0.0099	0.0072	0.00474	0.0021	0.00183
A4	0	0	0	0	0	0	0	0	0	0	0	0	0	0	0	0
A4B	0	0	0	0	0	0	0	0	0	0	0	0	0	0	0	0
C1	0	0	0	0.00215	0.00697	0.0111	0.0141	0.0166	0.0166	0.015	0.0114	0.0107	0.00876	0.00697	0.00644	0.00751
C2	0	0	0	0.000134	0.00309	0.00604	0.00926	0.00818	0.00604	0.00805	0.00697	0.00845	0.00899	0.00657	0.00711	0.00537
C2B	0	0	0	0.000179	0.00349	0.00823	0.0115	0.0143	0.0192	0.0192	0.0177	0.0177	0.0135	0.0109	0.00617	0.00349
C4	0	0	0	0	0	0	0	0	0	0	0	0	0	0	0	0
C5B	0	0	0	0	0	0	0	0	0	0	0	0	0	0	0	0
D	0	0	0	0	0	0	0	0	0	0	0	0	0	0	0	0
E	0	0	0	0	0	0	0	0	0	0	0	0	0	0	0	0
F	0	0	0	0	0	0	0	0	0	0	0	0	0	0	0	0
G	0	0	0	0	0	0	0	0	0	0	0	0	0	0	0	0

Xylene, 10-foot liner design.

Xylene

YEARS	DISTANCE FROM THE EDGE OF THE LANDFILL (feet)															
	0	5	10	15	20	25	30	35	40	45	50	60	70	80	90	100
A1	0	0	0	0	1	25	75	125	150	225	225	300	400	400	500	550
A2	0	0	0	0	0	0	0	0	0	0	0	0	1	50	75	100
A2B	0	0	0	0	0	0	0	0	0	0	0	0	1	1	1	75
A4	0	0	0	0	0	0	0	0	0	0	0	0	0	0	0	0
A4B	0	0	0	0	0	0	0	0	0	0	0	0	0	0	0	0
B	0	0	50	125	125	150	150	175	175	175	175	225	225	325	325	325
C1	0	0	0	0	0	0	0	0	0	0	0	0	0	0	0	0
C2	0	0	0	0	0	0	0	0	0	0	0	0	0	0	0	0
C2B	0	0	0	0	0	0	0	0	0	0	0	0	0	0	0	0
C4	0	0	0	0	0	0	0	0	0	0	0	0	0	0	0	0
C5	0	0	0	0	0	0	0	0	0	0	0	0	0	0	0	0
C5B	0	0	0	0	0	0	0	0	0	0	0	1	1	1	1	1
D	0	0	0	0	0	0	0	0	0	0	0	0	0	0	0	0
E	0	0	0	0	0	0	0	0	0	0	0	0	0	0	0	0
F	0	0	0	0	0	0	0	0	0	0	0	0	0	0	0	0
G	0	0	0	0	0	0	0	0	0	0	0	0	0	0	0	0

Xylene

YEARS	AVERAGE CONCENTRATION AT 100 FOOT COMPLIANCE LINE (ppm)															
	0	5	10	15	20	25	30	35	40	45	50	60	70	80	90	100
A1	0	0	0	0	0	0	0	0	0.000224	0.000224	0	0.000448	0	0.000448	0.000895	0.000448
A2	0	0	0	0	0	0	0	0	0	0	0	0	0	0	0	0.000224
A2B	0	0	0	0	0	0	0	0	0	0	0	0	0	0	0	0
A4	0	0	0	0	0	0	0	0	0	0	0	0	0	0	0	0
A4B	0	0	0	0	0	0	0	0	0	0	0	0	0	0	0	0
B	0	0	0	0	0	0.00099	0.00052	0.001	0	0.00051	0	0	0.00052	0	0.0005	0.00051
C1	0	0	0	0	0	0	0	0	0	0	0	0	0	0	0	0
C2	0	0	0	0	0	0	0	0	0	0	0	0	0	0	0	0
C2B	0	0	0	0	0	0	0	0	0	0	0	0	0	0	0	0
C4	0	0	0	0	0	0	0	0	0	0	0	0	0	0	0	0
C5	0	0	0	0	0	0	0	0	0	0	0	0	0	0	0	0
C5B	0	0	0	0	0	0	0	0	0	0	0	0	0	0	0	0
D	0	0	0	0	0	0	0	0	0	0	0	0	0	0	0	0
E	0	0	0	0	0	0	0	0	0	0	0	0	0	0	0	0
F	0	0	0	0	0	0	0	0	0	0	0	0	0	0	0	0
G	0	0	0	0	0	0	0	0	0	0	0	0	0	0	0	0

Xylene, 3-foot liner design.

Xylene

YEARS	DISTANCE FROM THE EDGE OF THE LANDFILL (feet)															
	0	5	10	15	20	25	30	35	40	45	50	60	70	80	90	100
A1	0	0	25	100	125	175	250	300	350	400	450	500	600	650	700	850
A2	0	0	1	25	75	75	125	150	175	225	250	300	400	400	500	550
A2B	0	0	1	25	75	75	125	150	175	225	250	350	350	400	500	500
A4	0	0	0	0	0	0	0	0	0	0	0	0	0	1	1	1
A4B	0	0	0	0	0	1	1	1	1	1	25	50	75	75	75	75
C1	0	0	0	75	100	150	225	250	300	350	450	450	550	600	700	750
C2	0	0	1	25	75	100	125	150	175	200	225	300	300	400	400	450
C2B	0	0	1	25	50	75	100	125	175	175	250	250	350	400	450	450
C4	0	0	0	0	0	0	0	0	0	0	0	0	0	0	0	0
C5B	0	0	0	0	0	0	0	0	0	0	0	0	0	0	0	1
D	0	0	0	0	0	0	0	0	0	0	0	0	0	0	0	0
E	0	0	0	0	0	0	0	0	0	0	0	0	0	0	0	0
F	0	0	0	0	0	0	0	0	0	0	0	0	0	0	0	0
G	0	0	0	0	0	0	0	0	0	0	0	0	0	0	0	0

Xylene

YEARS	AVERAGE CONCENTRATION AT 100 FOOT COMPLIANCE LINE (ppm)															
	0	5	10	15	20	25	30	35	40	45	50	60	70	80	90	100
A1	0	0	0	0.000022	0.000112	0.000805	0.00121	0.0024	0.00316	0.00379	0.00426	0.00441	0.00466	0.00468	0.00414	0.00273
A2	0	0	0	0	0	0	0.000078	0.000213	0.000493	0.000896	0.00115	0.00179	0.00227	0.00234	0.00253	0.00297
A2B	0	0	0	0	0	0	0.000078	0.000202	0.000458	0.000964	0.00114	0.00184	0.00242	0.00256	0.00264	0.00267
A4	0	0	0	0	0	0	0	0	0	0	0	0	0	0	0	0
A4B	0	0	0	0	0	0	0	0	0	0	0	0	0	0	0	0
C1	0	0	0	0	0.000134	0.000313	0.0013	0.00152	0.00184	0.00206	0.00201	0.00242	0.0021	0.00179	0.00219	0.00161
C2	0	0	0	0	0	0	0.000168	0.000403	0.000772	0.000907	0.00114	0.00134	0.00144	0.00138	0.00121	0.00101
C2B	0	0	0	0	0	0	0.000112	0.000112	0.000381	0.00094	0.00179	0.00213	0.00251	0.00278	0.00316	0.00313
C4	0	0	0	0	0	0	0	0	0	0	0	0	0	0	0	0
C5B	0	0	0	0	0	0	0	0	0	0	0	0	0	0	0	0
D	0	0	0	0	0	0	0	0	0	0	0	0	0	0	0	0
E	0	0	0	0	0	0	0	0	0	0	0	0	0	0	0	0
F	0	0	0	0	0	0	0	0	0	0	0	0	0	0	0	0
G	0	0	0	0	0	0	0	0	0	0	0	0	0	0	0	0

Appendix B: Plots

Plots of concentration and head distribution are given for each contaminant simulated for the 10-foot landfill liner design of the A1 scenario. Representative plots for other scenarios are also included. A complete set of plots is on open file at the Illinois State Geological Survey.

Many of the contoured plumes appear to have greater extent than those reported in table 6. This discrepancy is a result of extrapolation by the plotting program. The data in table 6 are taken directly from the PLASM/Random Walk output files and reflect the actual estimates of contaminant transport predicted with the PLASM/Random Walk model.

Steady-state head distribution predicted by PLASM, A1 scenario, 10-foot liner design. Contour interval is 2 feet.

Head, Layer 1, A1TENX, Sand 20 feet thick

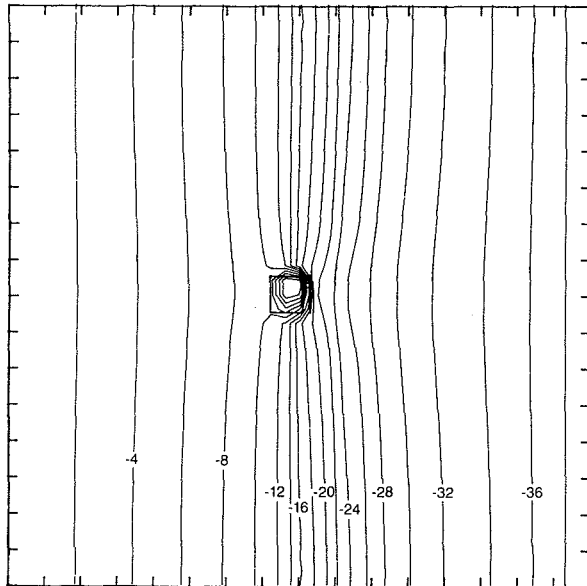

Head, Layer 2, A1TENX, Limestone 15 feet thick

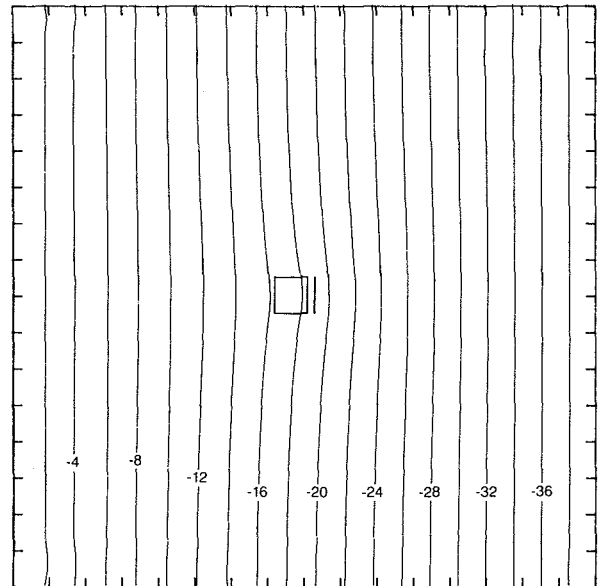

Head, Layer 3, A1TENX, Limestone 15 feet thick

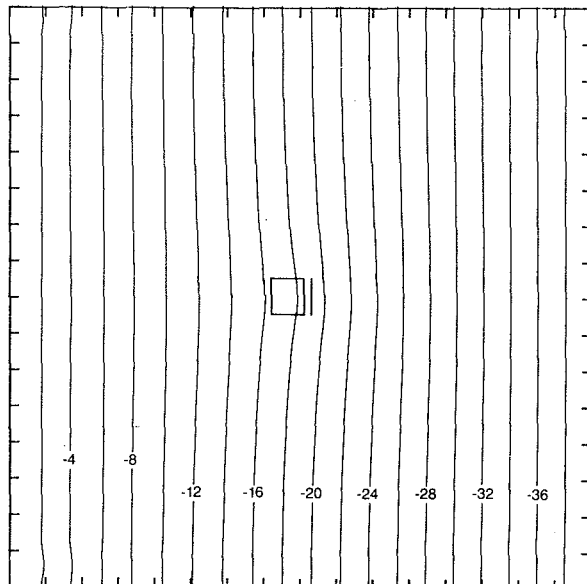

0 2000 4000 ft

Chloride distribution, predicted by PLASM/Random Walk, A1 scenario, 10-foot liner design. Simulated time, 100 years; contour interval varies; concentration in ppm.

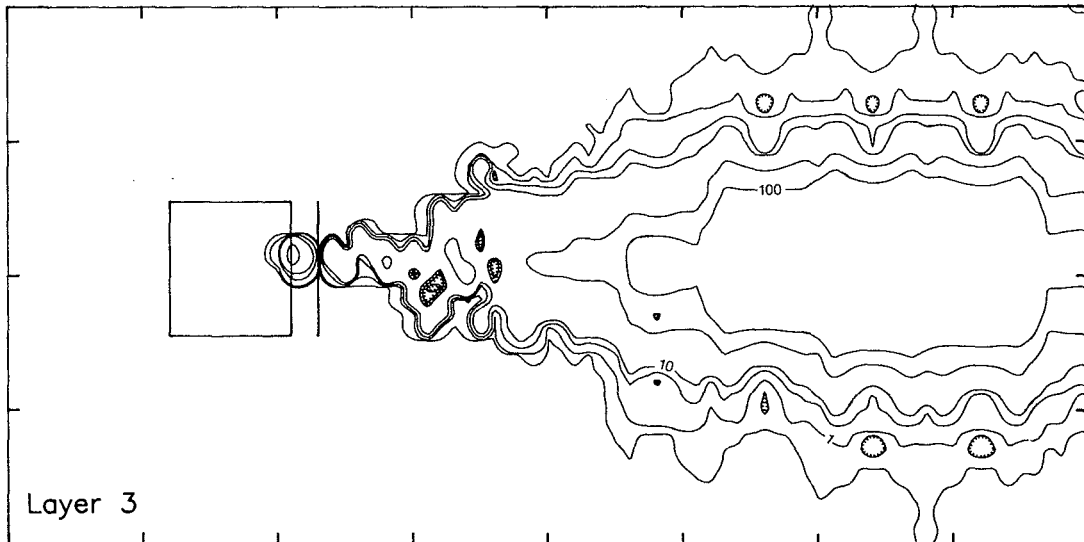
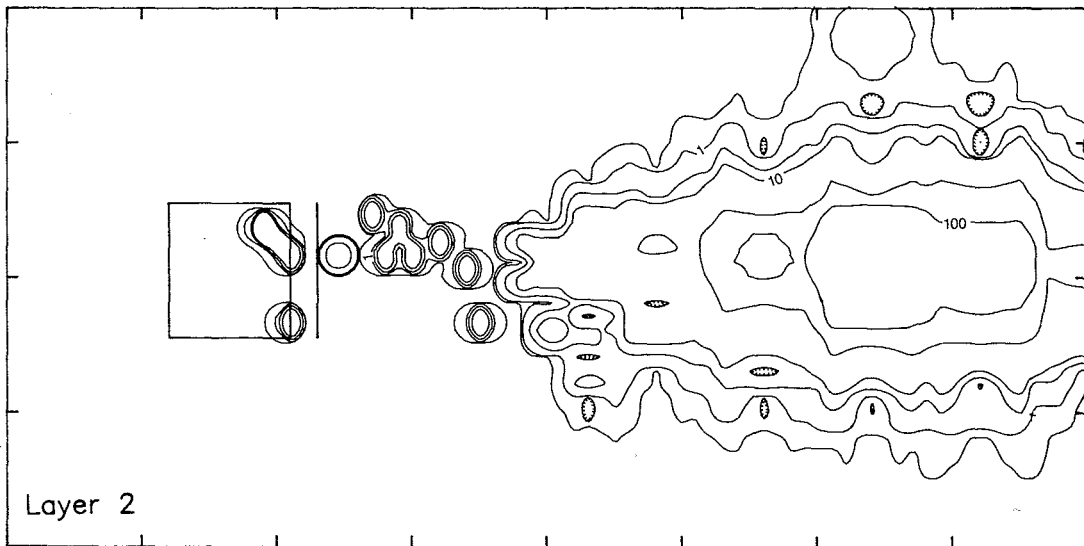
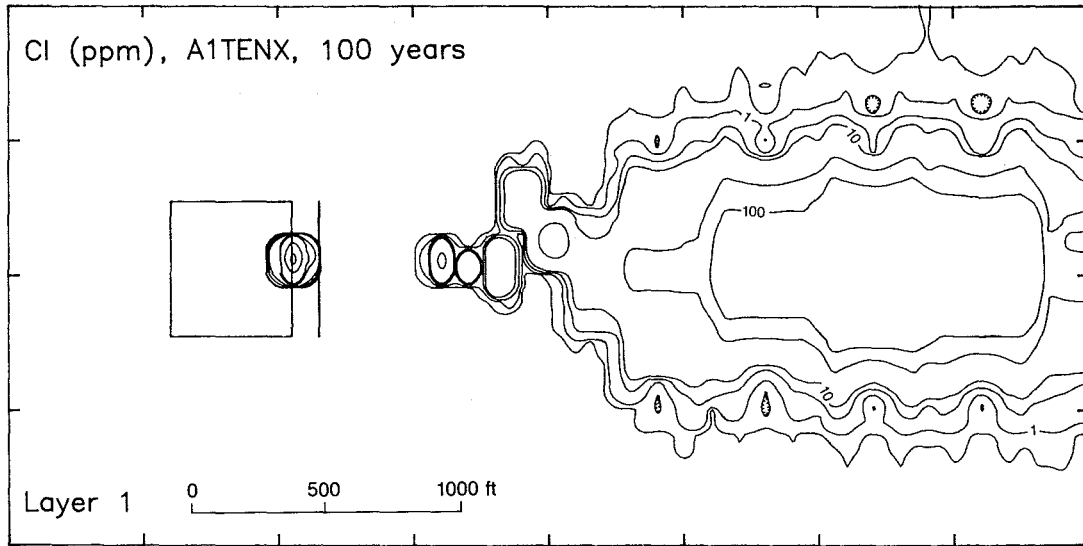

Cadmium distribution, predicted by PLASM/Random Walk, A1 scenario, 10-foot liner design. Simulated time, 100 years; contour interval varies; concentration in ppm. No migration of cadmium predicted for layers 2 and 3.

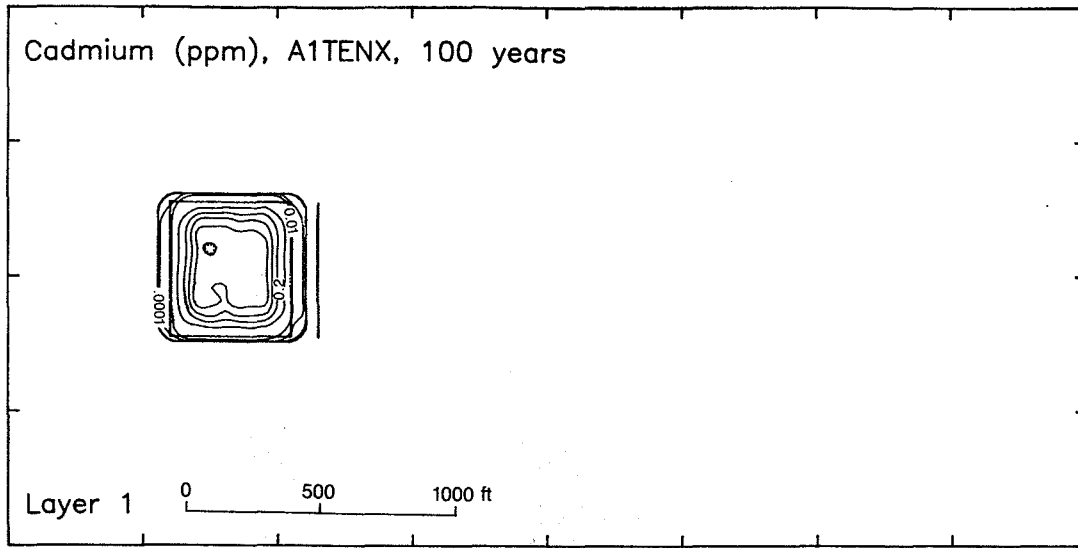

COD distribution, predicted by PLASM/Random Walk, A1 scenario, 10-foot liner design. Simulated time, 100 years; contour interval varies; concentration in ppm.

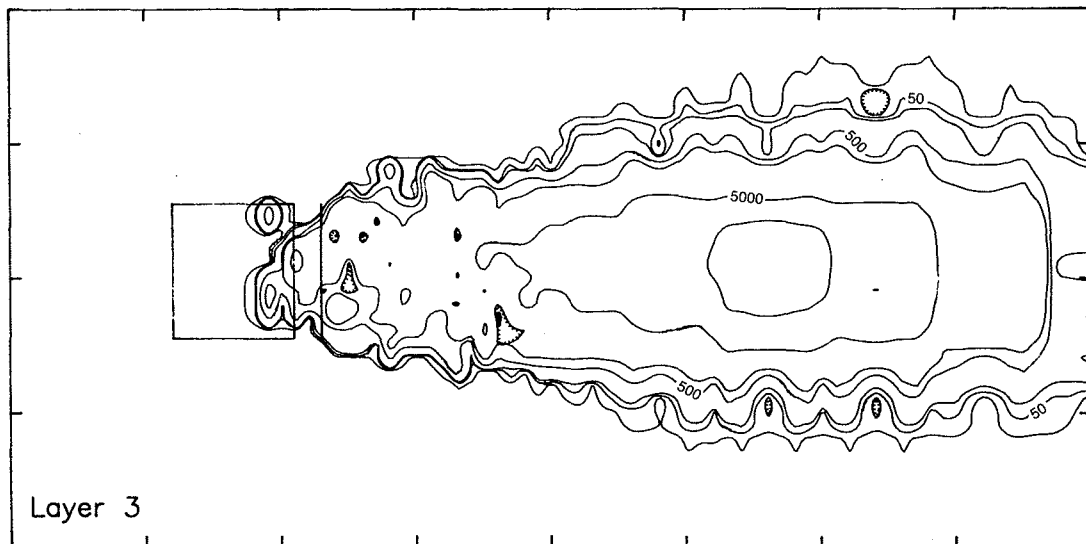
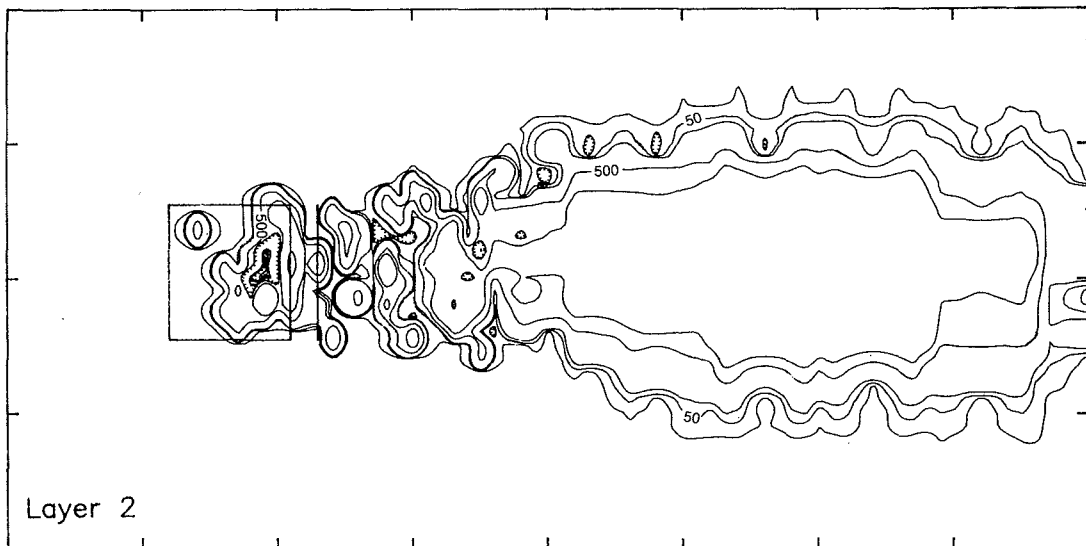
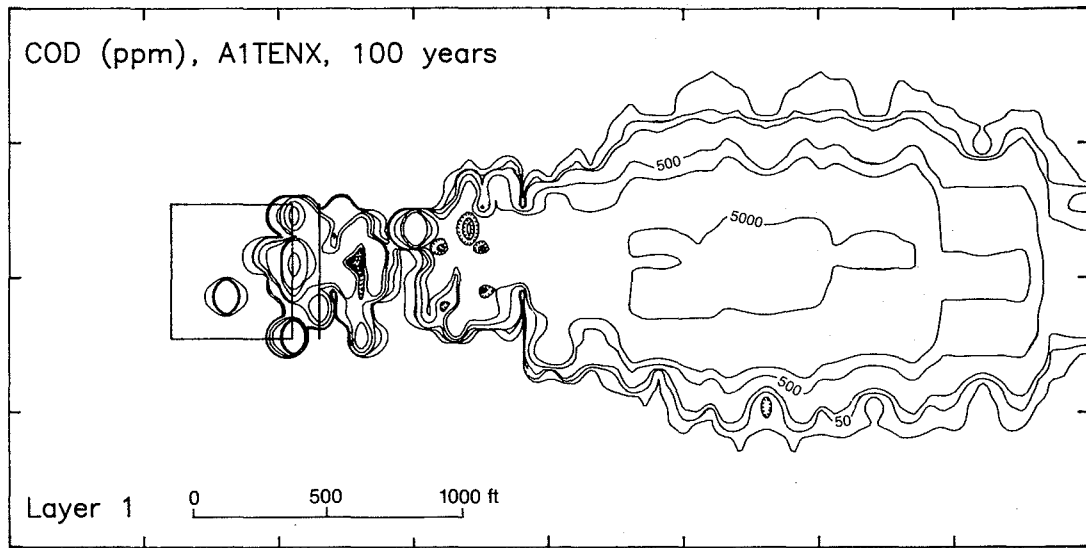

Methylene chloride distribution, predicted by PLASM/Random Walk, A1 scenario, 10-foot liner design. Simulated time, 100 years; contour interval varies; concentration in ppm.

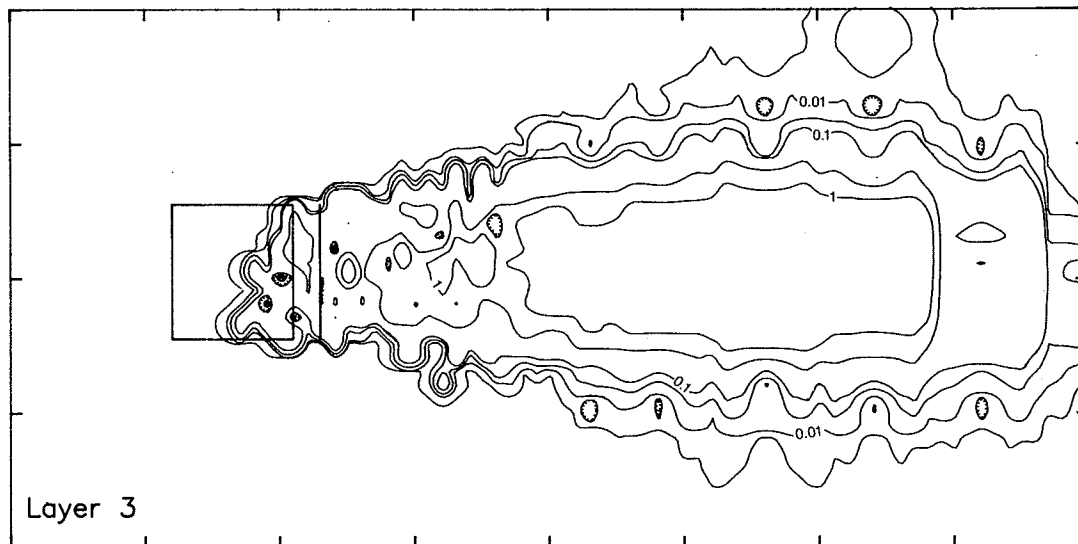
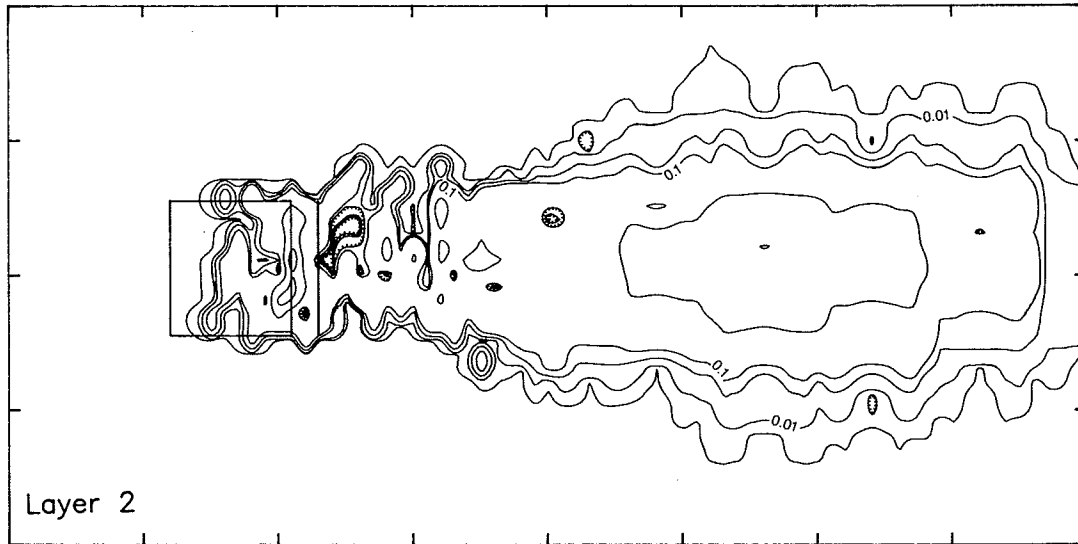
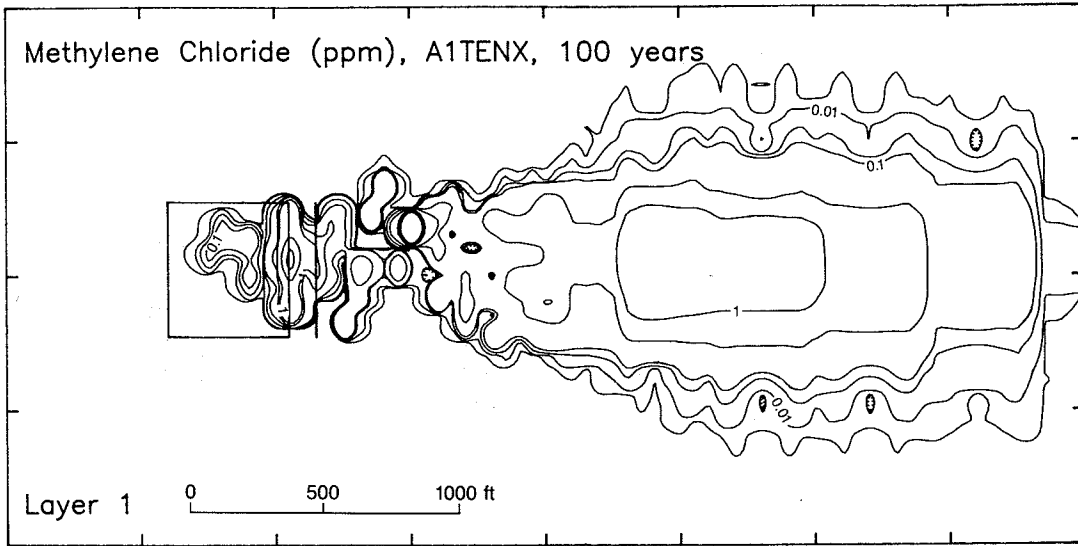

TCE distribution, predicted by PLASM/Random Walk, A1 scenario, 10-foot liner design. Simulated time, 100 years; contour interval varies; concentration in ppm.

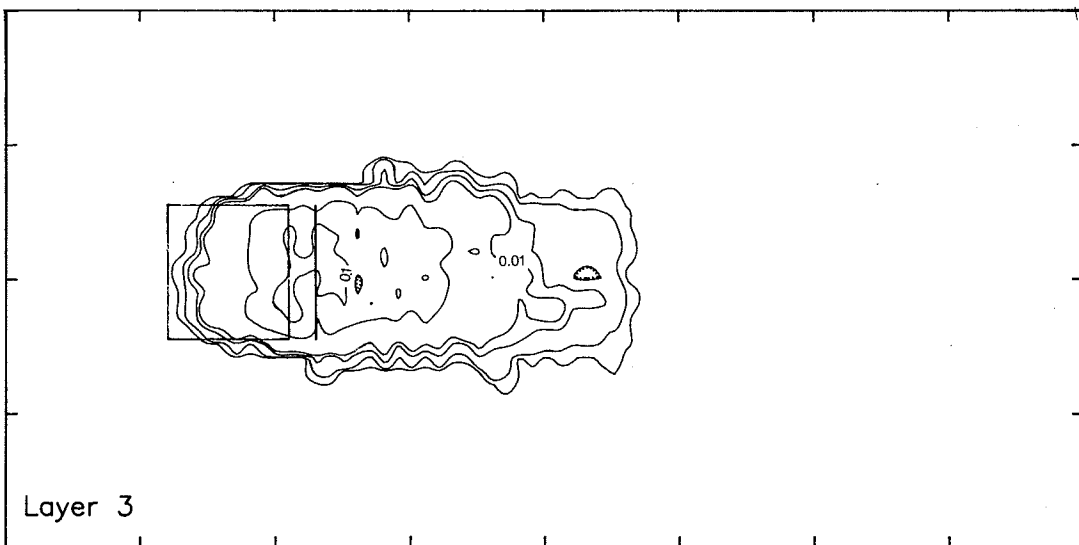
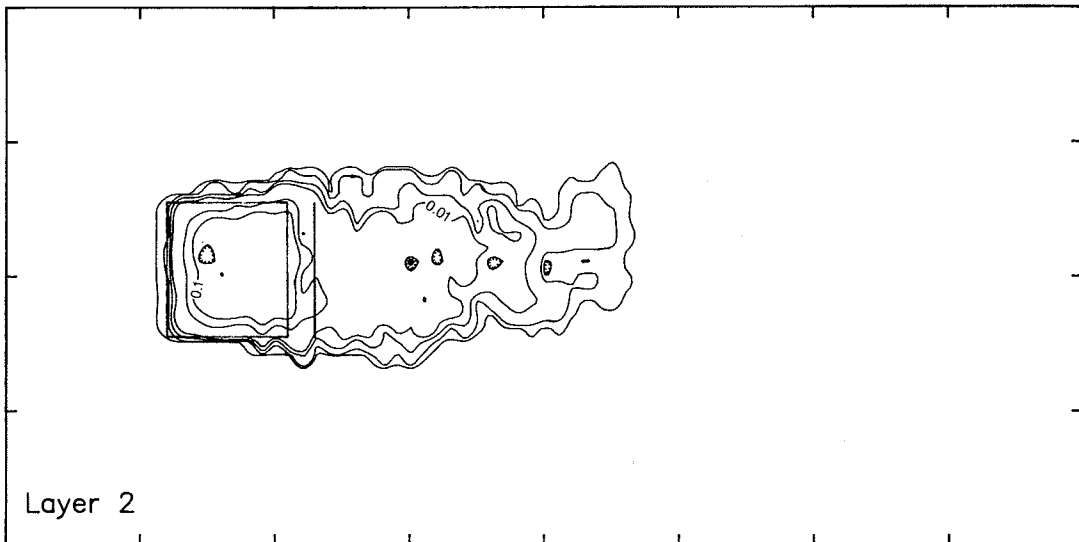
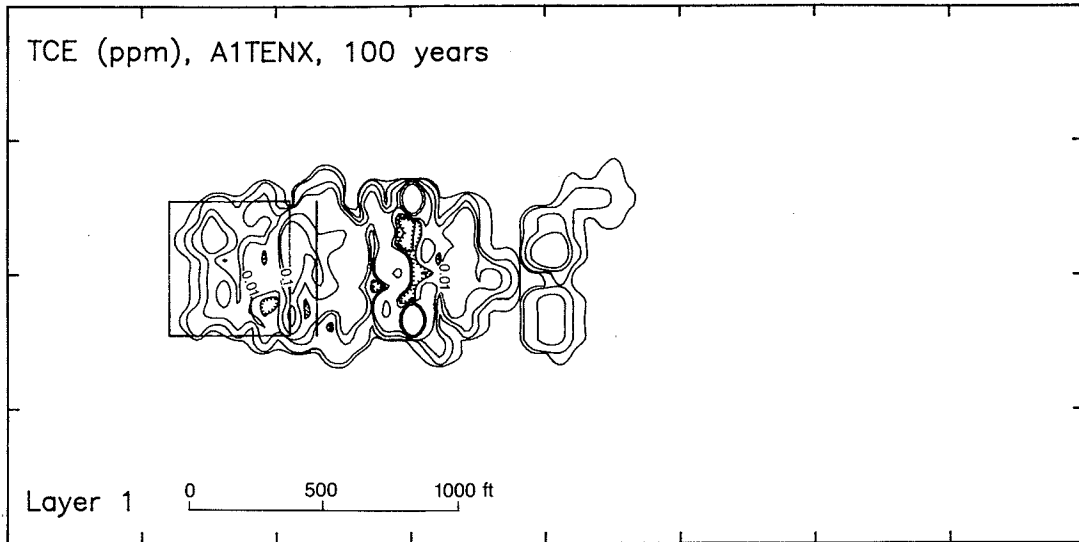

Xylene distribution, predicted by PLASM/Random Walk, A1 scenario, 10-foot liner design. Simulated time, 100 years; contour interval varies; concentration in ppm.

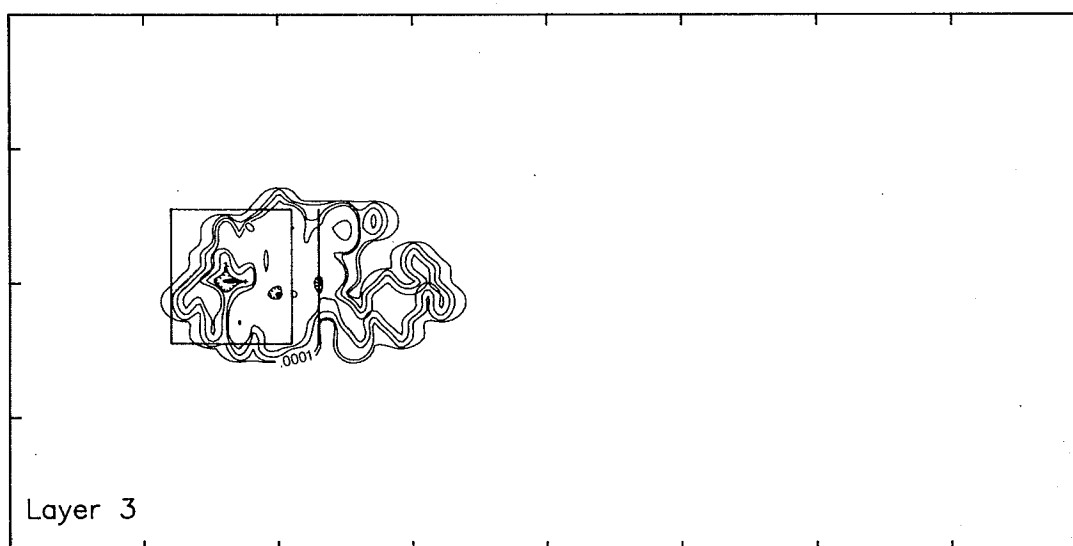
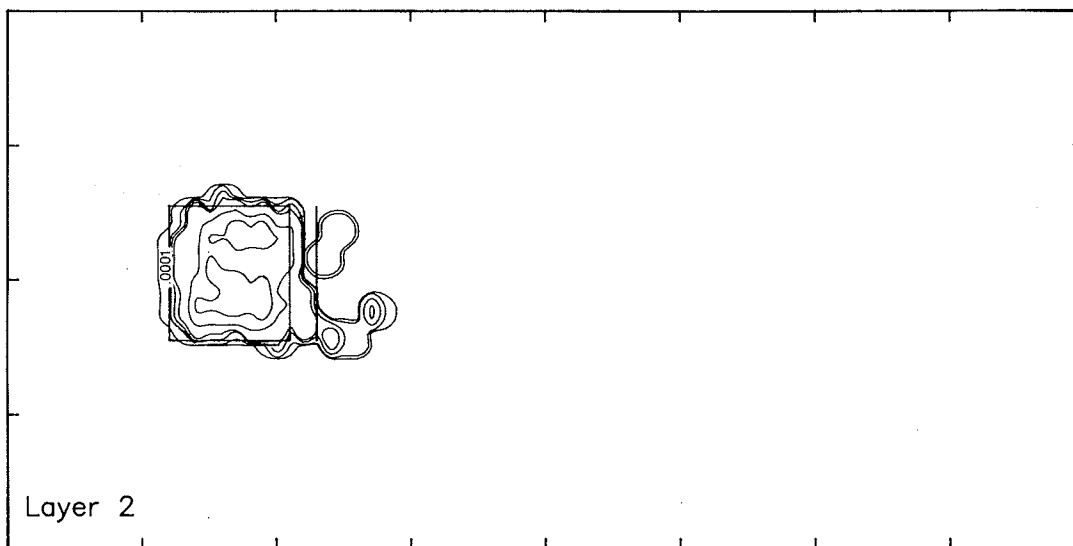
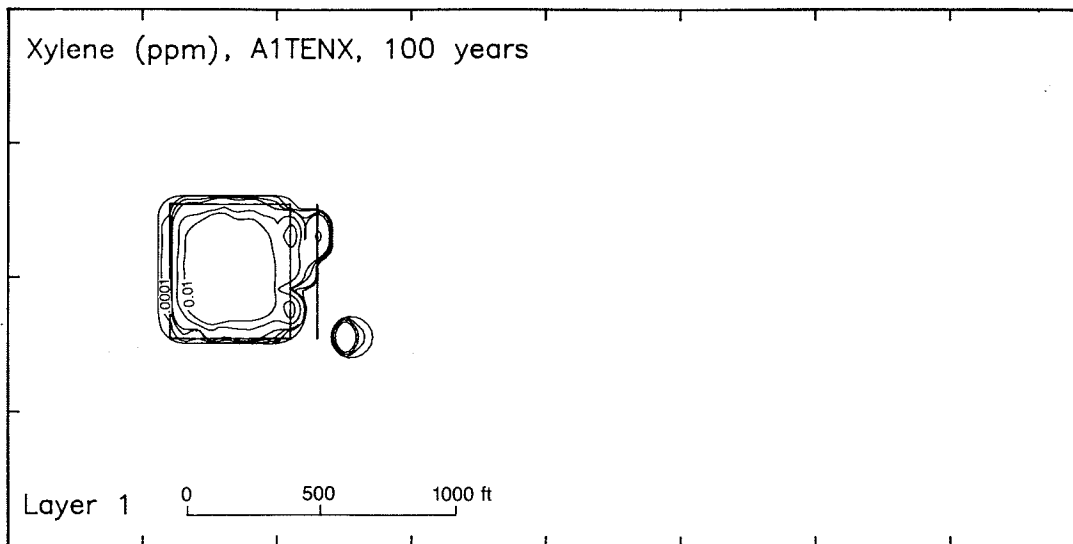

Chloride and Xylene distributions, layer 3, A2 scenario, 3-foot liner design. Simulated time, 100 years; contour interval varies; concentration in ppm. This figure illustrates the effect of the retardation factor for a contaminant of low mobility (xylene retardation factor = 5.47) compared to a contaminant of conservative mobility (chloride retardation factor = 1.00).

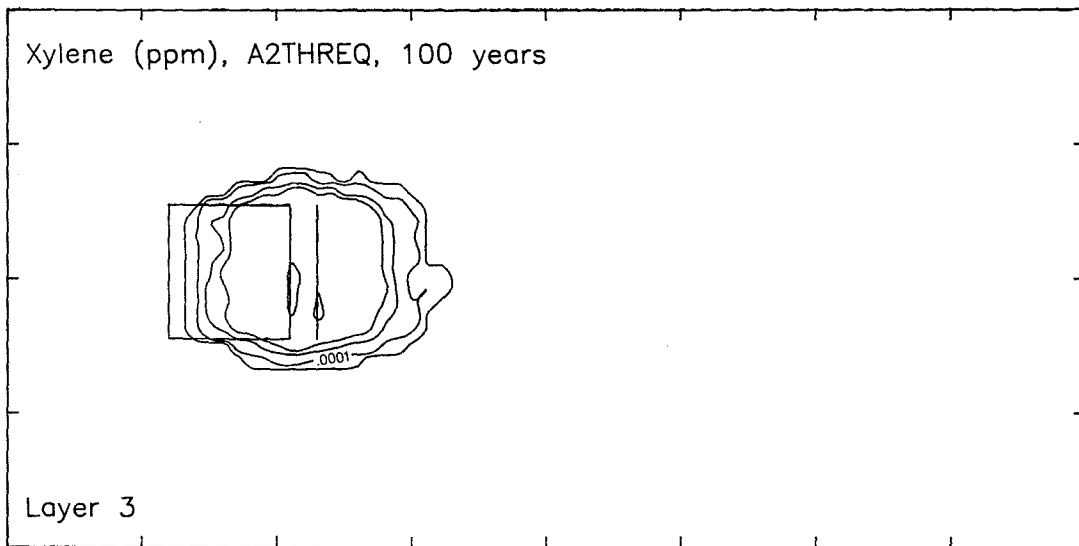
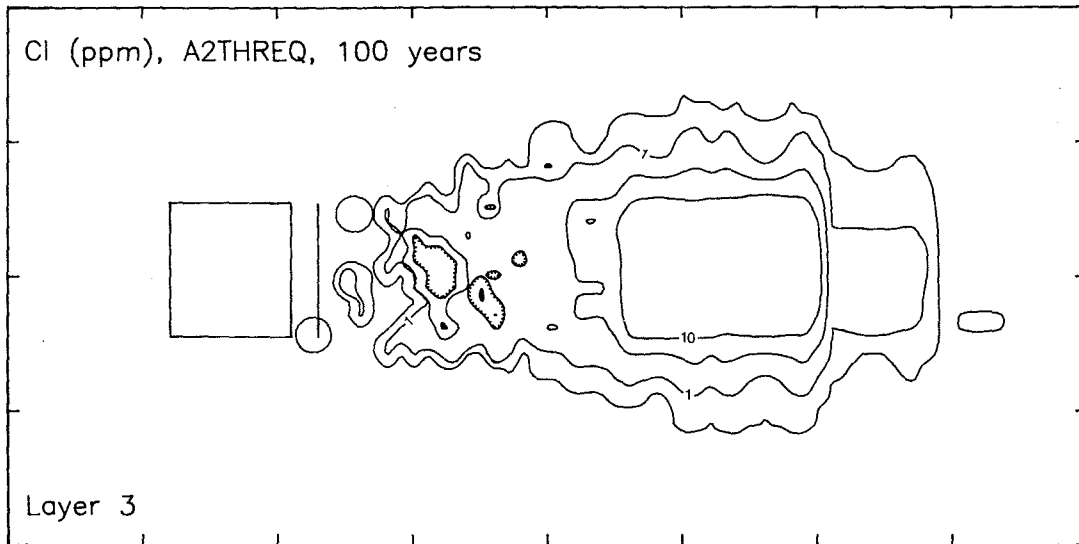

0 500 1000 ft

Chloride and methylene chloride distributions, layer 3, A2b scenario, 10-foot liner design. Simulated time, 100 years; contour interval varies; concentration in ppm. This figure illustrates the effect of retardation factor for a contaminant of high mobility (methylene chloride retardation factor = 1.23) compared to a conservative contaminant (chloride retardation factor = 1.00).

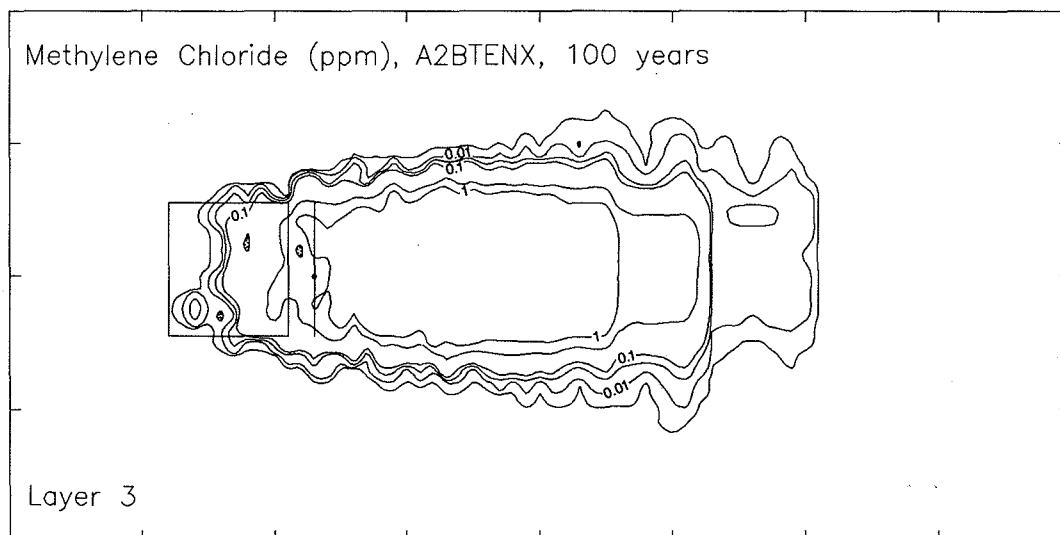
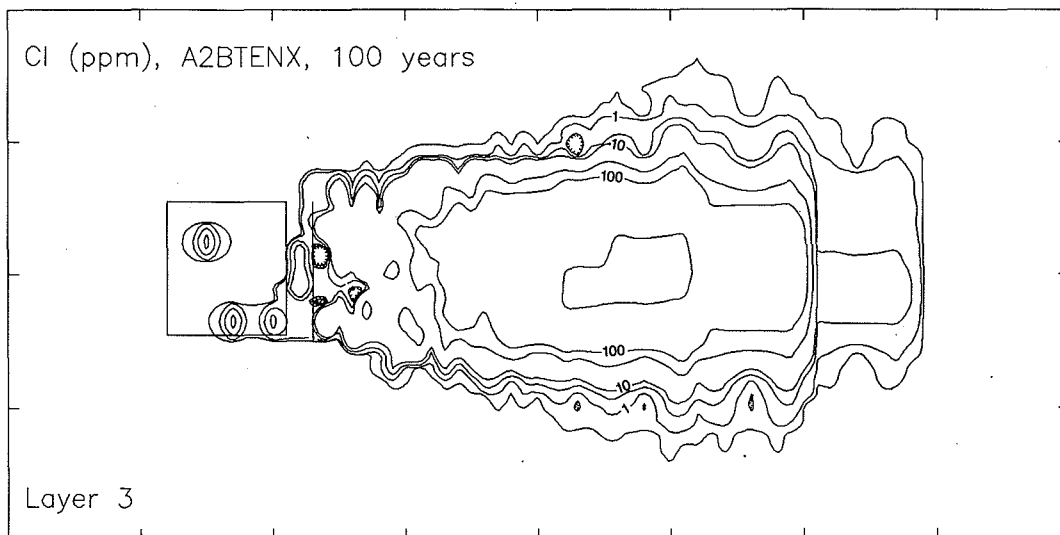

0 500 1000 ft

Chloride and cadmium distributions, layer 2, A4 scenario, 3-foot liner design. Simulated time, 100 years; contour interval varies; concentration in ppm. The hydraulic conductivity of this material is two orders of magnitude lower than for the A1 and A2 scenarios. Chloride still migrates to the proposed 100-foot compliance distance (denoted by line right of landfill box); cadmium migration is insignificant.

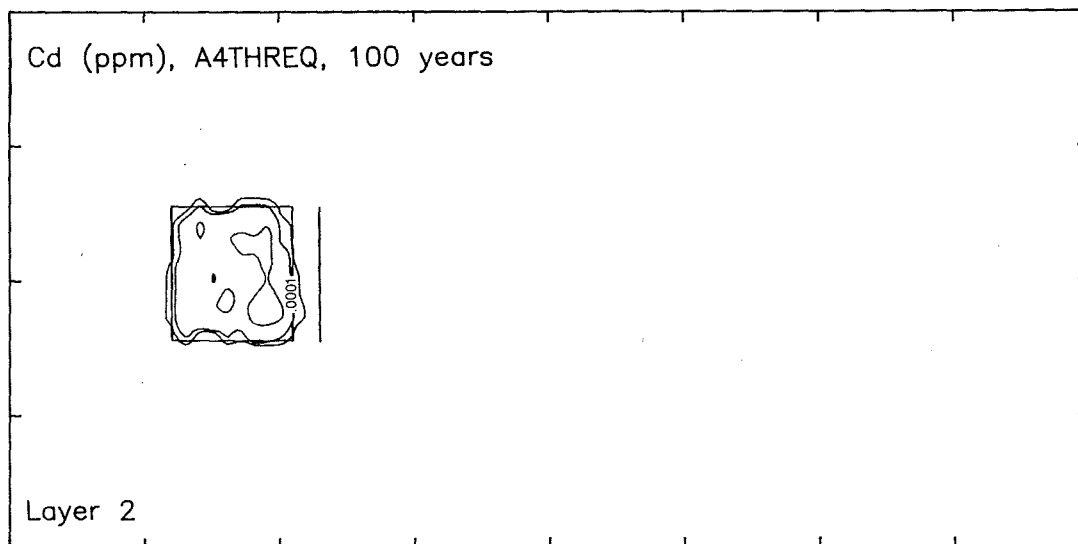
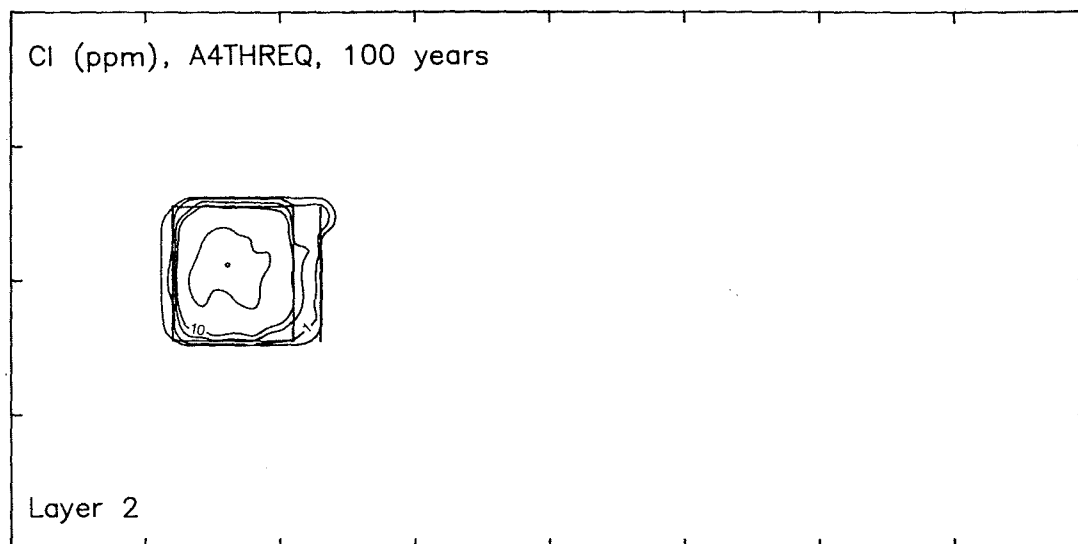

0 500 1000 ft

Chloride and TCE distributions, layer 3, A4b scenario, 3-foot liner design. Simulated time, 100 years; contour interval varies; concentration in ppm. Aquifer has hydraulic conductivity one order of magnitude greater than A4 scenario. Chloride plume is more extensive than in the previous figure. Large lateral extent of plume is a result of groundwater mounding. TCE has lower mobility (retardation factor = 2.81) than chloride.

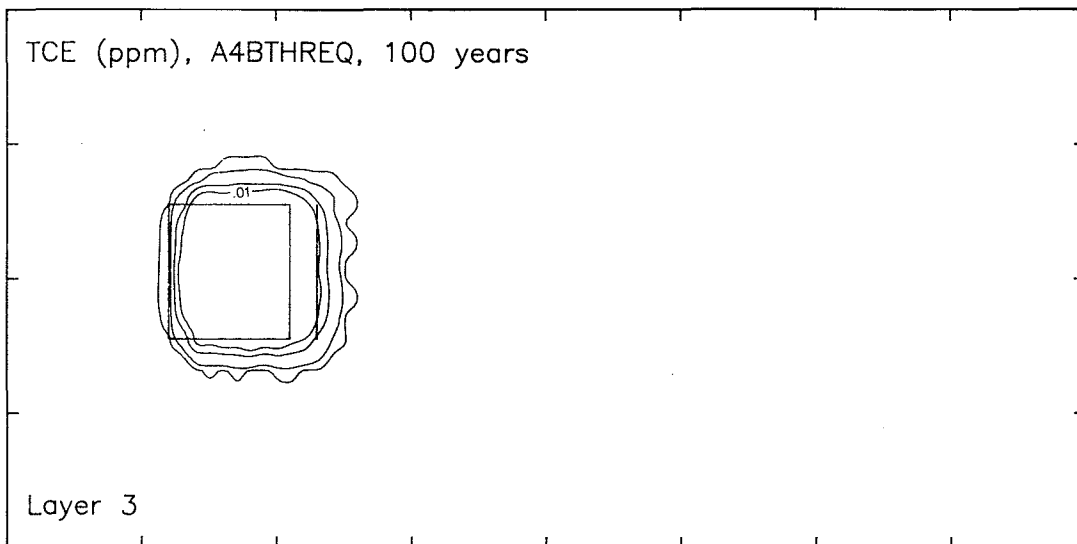
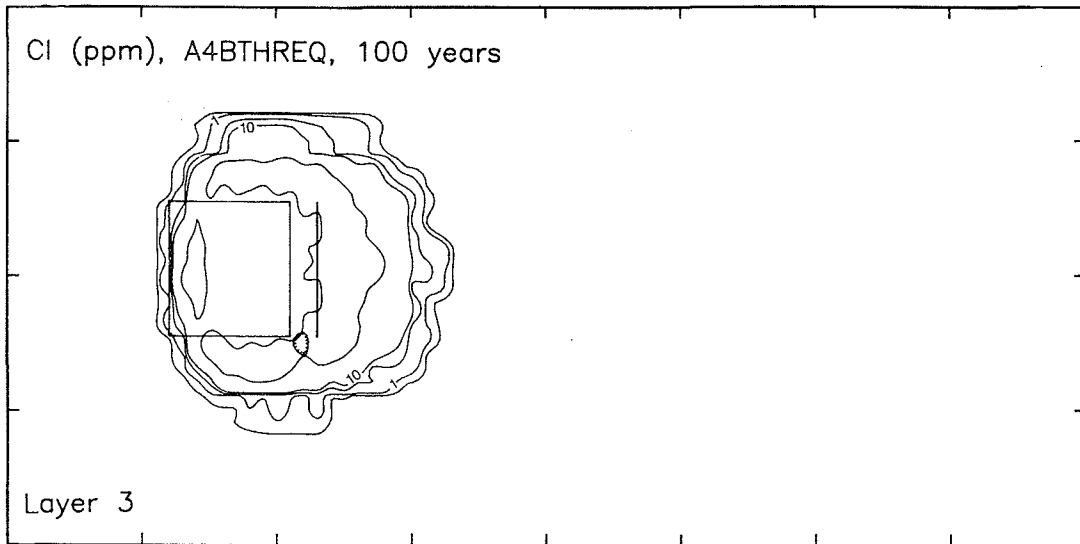

0 500 1000 ft

Chloride and Xylene distributions, layer 1, B scenario, 10-foot liner design. Simulated time, 100 years; contour interval varies; concentration in ppm. Plumes appear to be equally extensive; however, particles representing chloride migrated to the lower confining layers where movement was arrested because of low hydraulic conductivity.

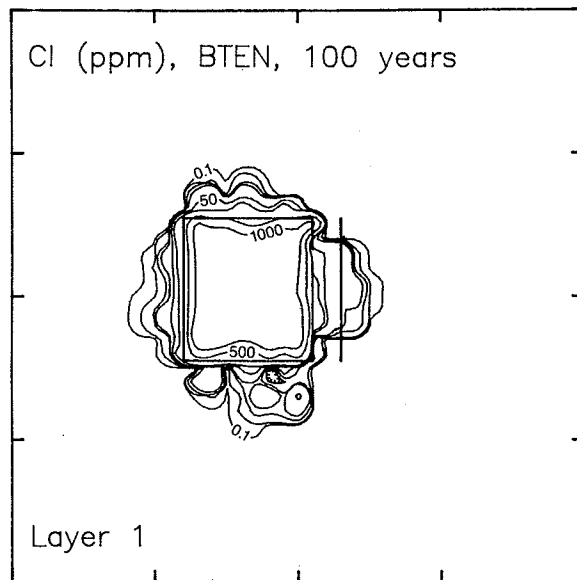
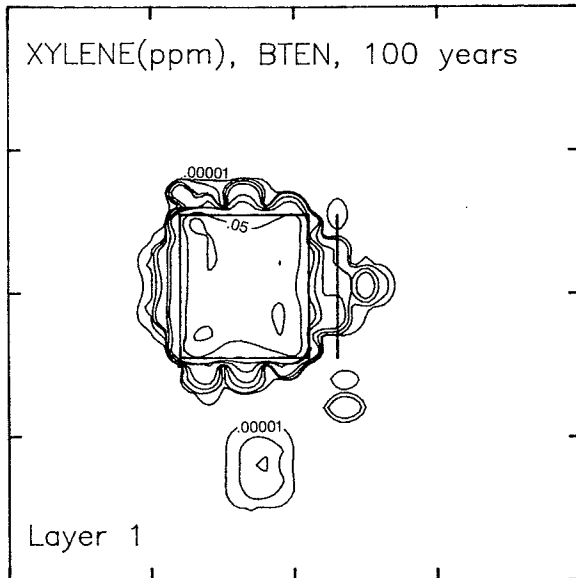

0 500 1000 ft

TCE distributions, layer 3, C1 scenario, 10-foot and 3-foot liner designs. Simulated time, 100 years; contour interval varies; concentration is in ppm. The low mobility TCE particles required a greater amount of time to travel through the 10-foot liner and underlying confining layer of this scenario than through the 3-foot liner and its underlying confining layer. Thus particles for the simulation utilizing the 10-foot liner reached the aquifer at a later time, and overall migration extent was greatly reduced.

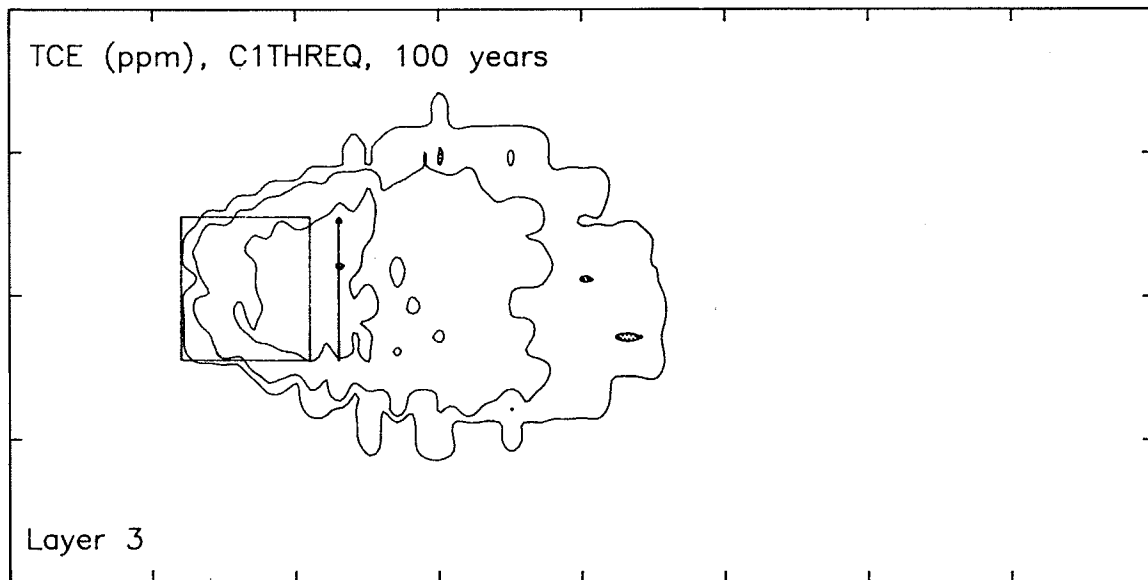
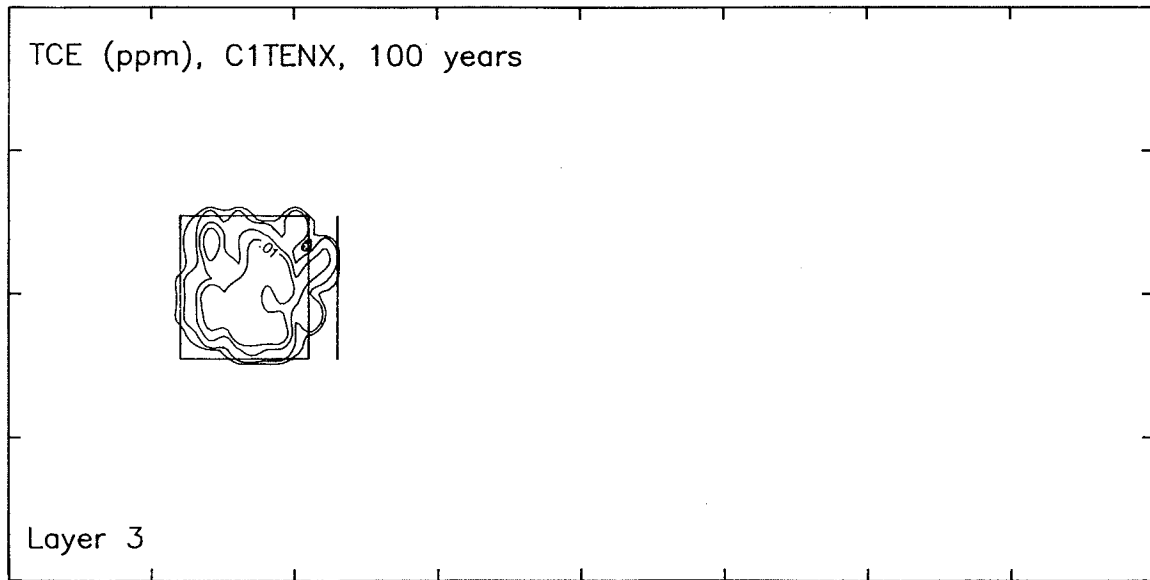

0 500 1000 ft

Chloride and methylene chloride distributions, layer 3, C2 scenario, 10-foot liner design. Simulated time, 100 years; contour interval varies; concentration is in ppm. Finger extension of downgradient plume was extrapolated by contouring package. Maximum extent from raw data file was 1350 feet from landfill.

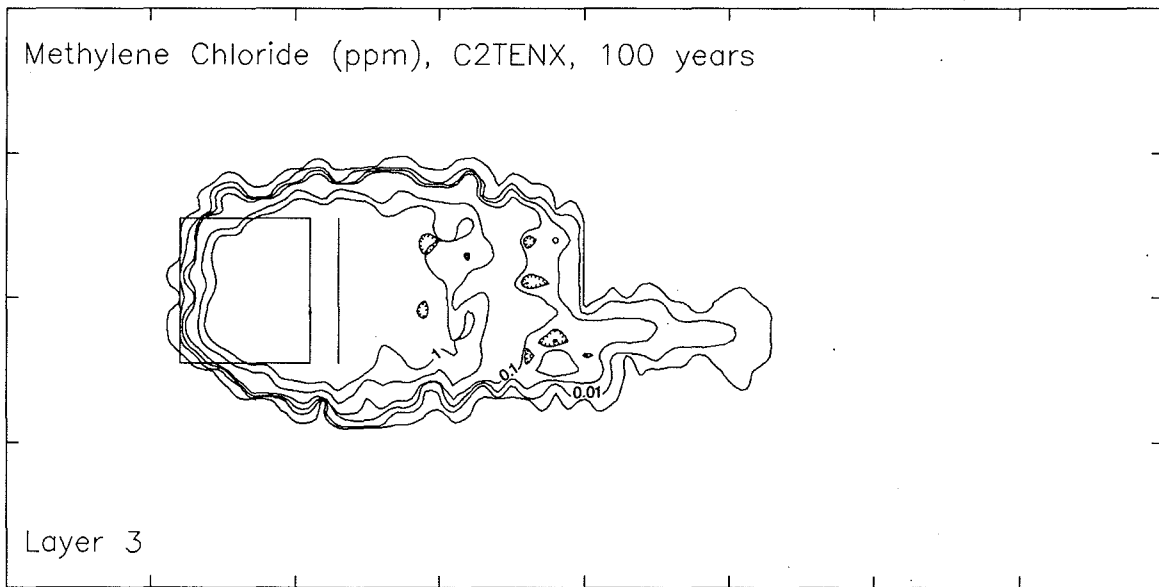
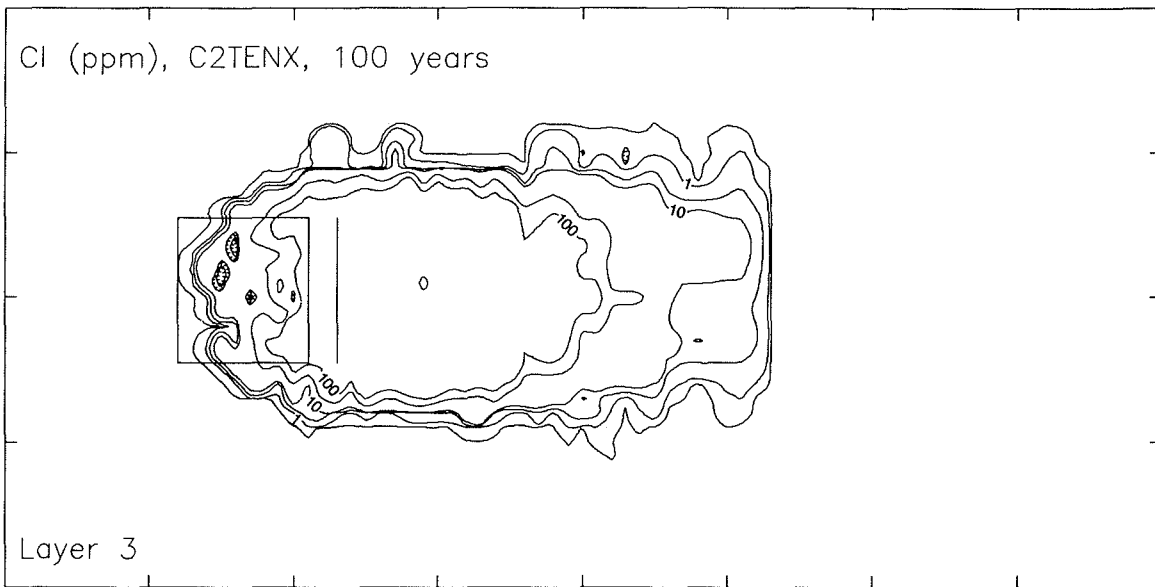

0 500 1000 ft

Chloride and methylene chloride distributions, layer 3, C2b scenario, 10-foot liner design, Simulated time, 100 years; contour interval varies; concentration is in ppm. The confining layer of the C2b scenario is thicker, but has lower hydraulic conductivity than that of the C2 scenario. Note the greater extent of these plumes (compared to chloride and methylene chloride distribution, layer 3, C2 scenario), indicating more rapid migration of particles through the confining layer of the C2b scenario.

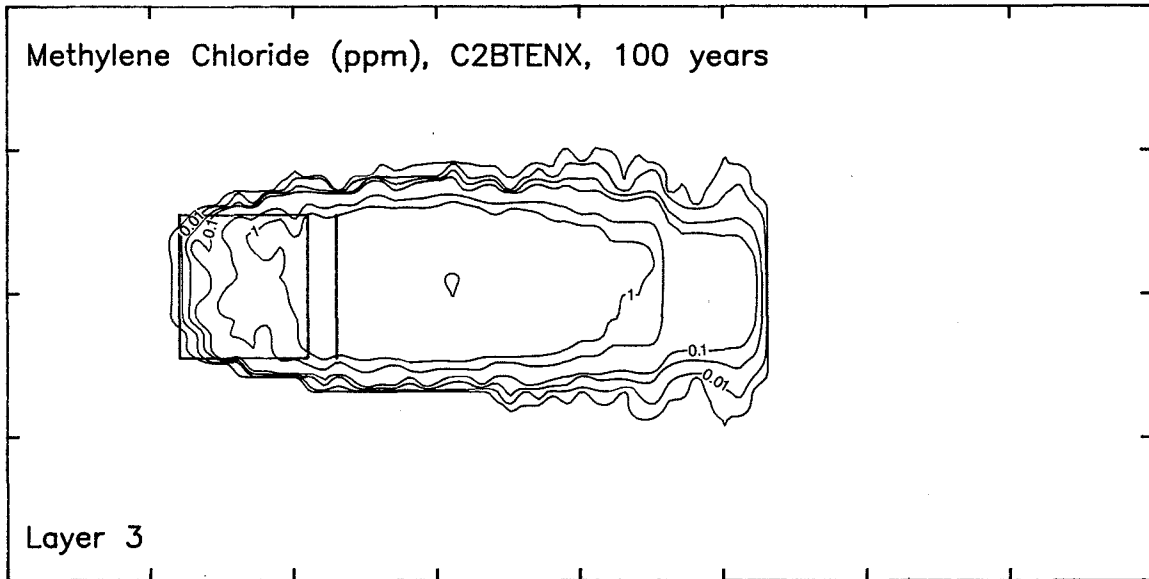
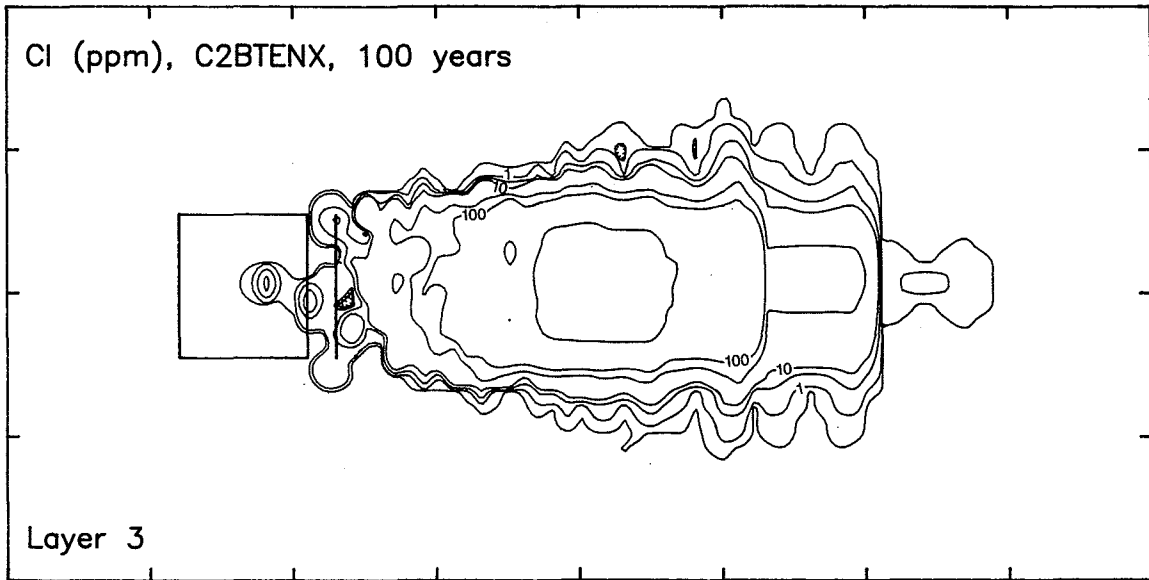

0 500 1000 ft

Chloride and COD distributions, layer 3, C4 scenario, 3-foot liner design. Simulated time, 100 years; contour interval varies; concentration is in ppm. Neither contaminant had extensive migration.

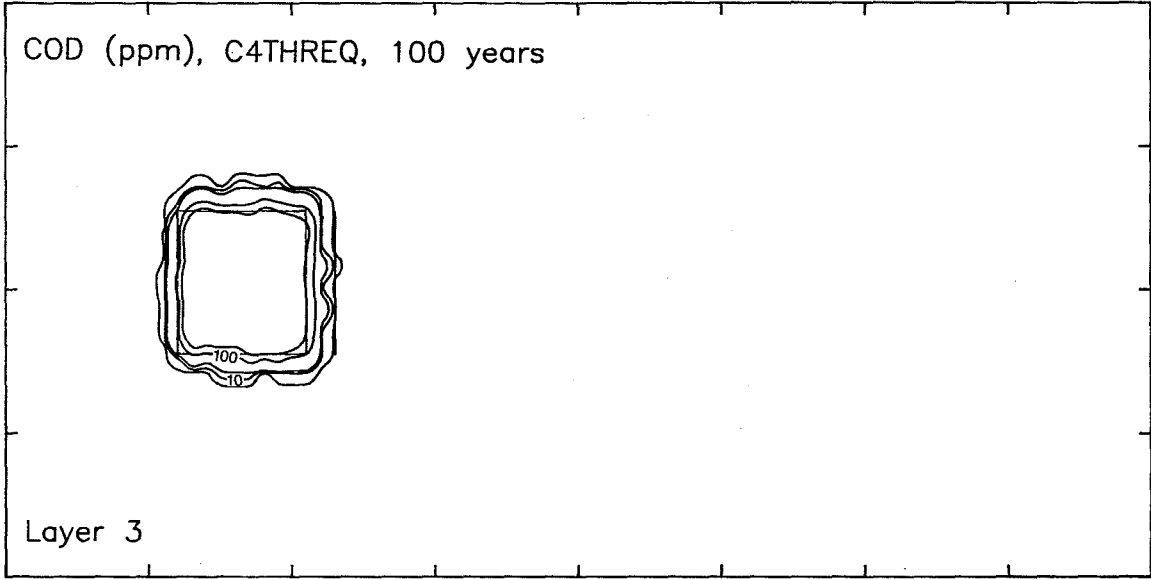
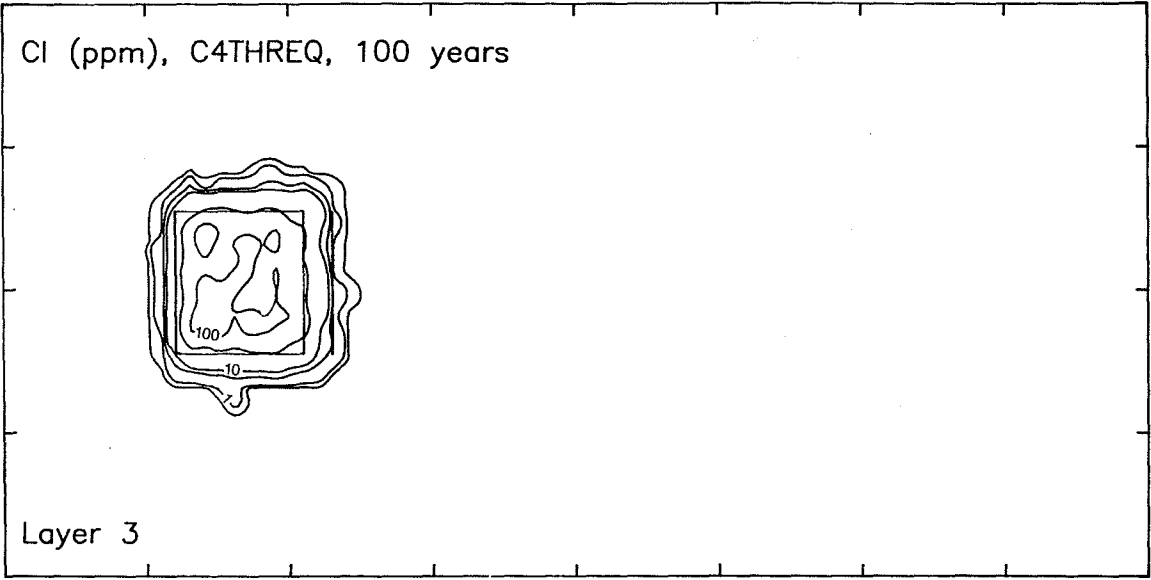

0 500 1000 ft

Chloride distributions, layers 1 and 3, C5 scenario, 10-foot liner design. Simulated time, 100 years; contour interval varies; concentration is in ppm. The sand lens of this scenario underlies the half of the landfill toward the bottom of the page. Layer 1 is the uppermost layer containing the landfill. Note that most of the particles in that portion of the landfill overlying the sand lens have migrated to layer 3 (which contains the sand lens).

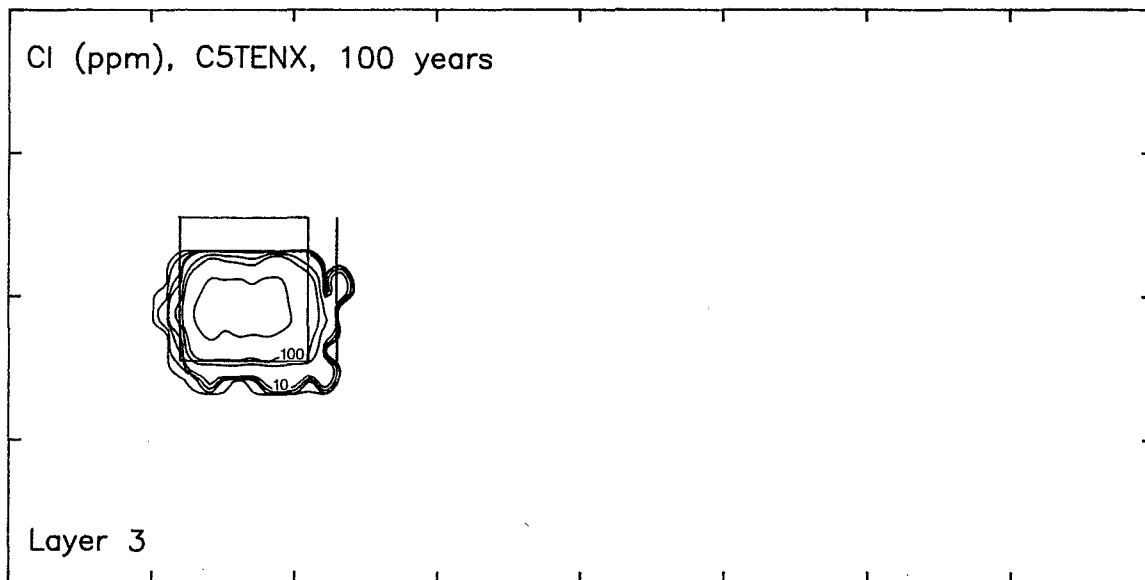
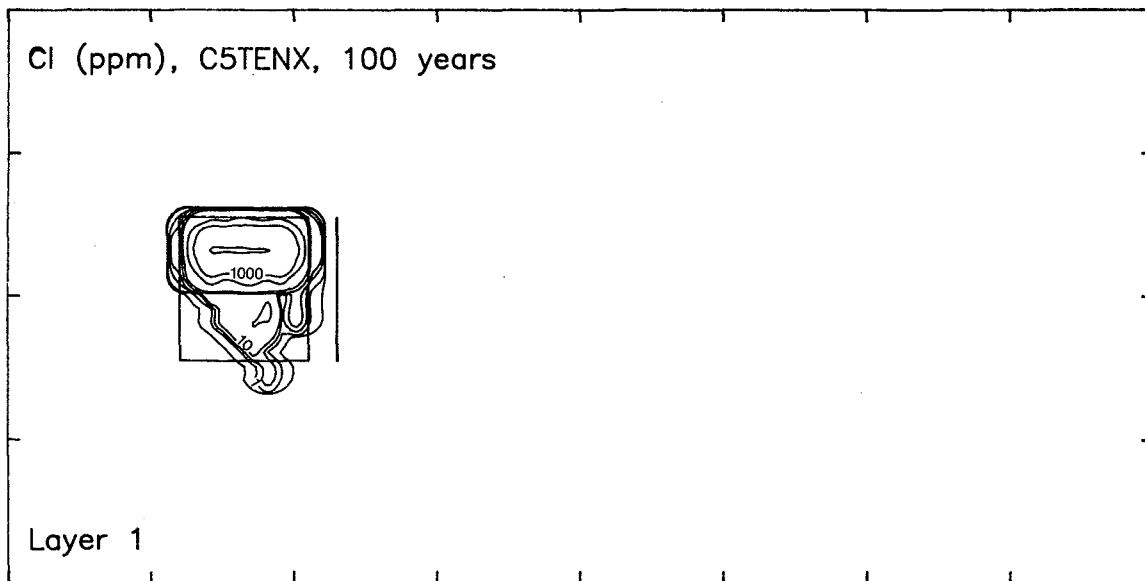

0 500 1000 ft

Chloride and TCE distributions, layer 3, C5b scenario, 3-foot liner design. Simulated time, 100 years; contour interval varies; concentration is in ppm. Little migration occurred for this scenario.

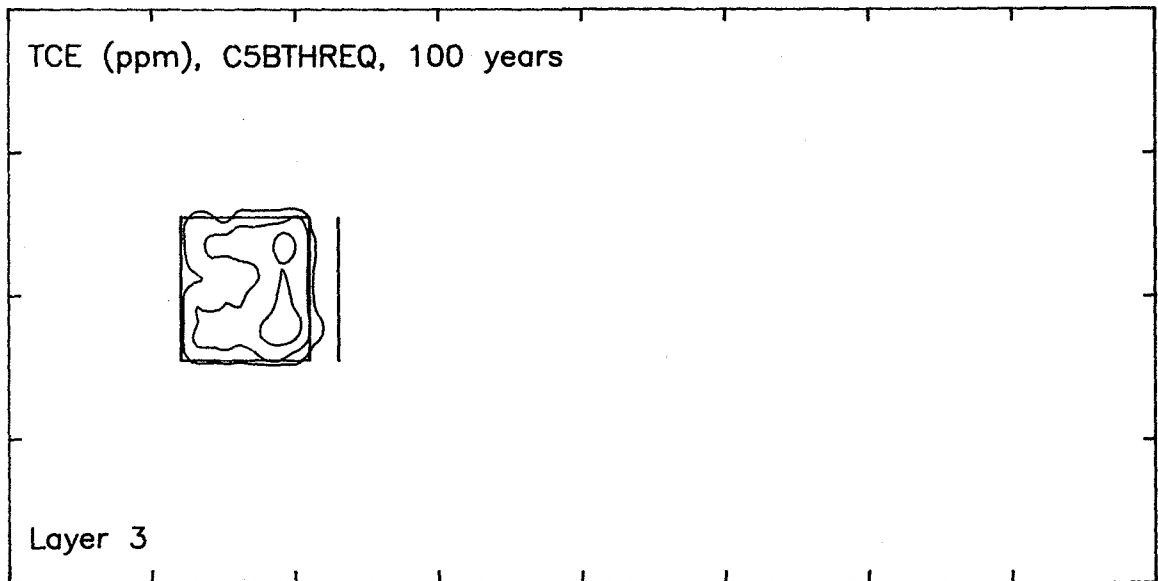
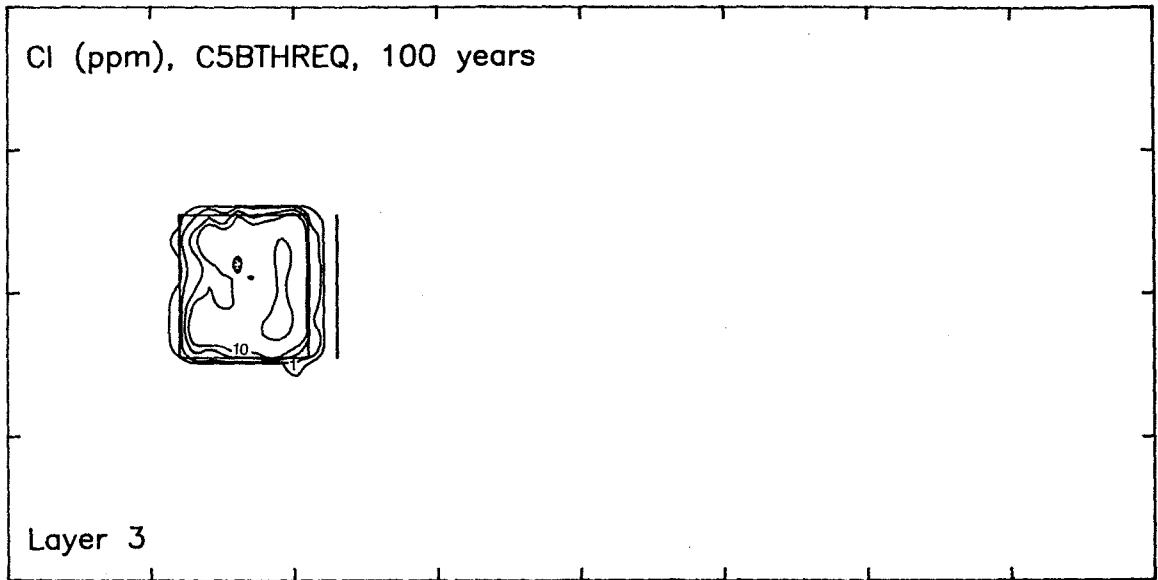

0 500 1000 ft

Chloride and methylene chloride concentrations, D scenario, 10-foot liner design. Simulated time, 100 years; contour interval varies; concentration is in ppm. No aquifer is included in this scenario. Few particles migrated from the landfill nodes to the nodes representing the underlying materials.

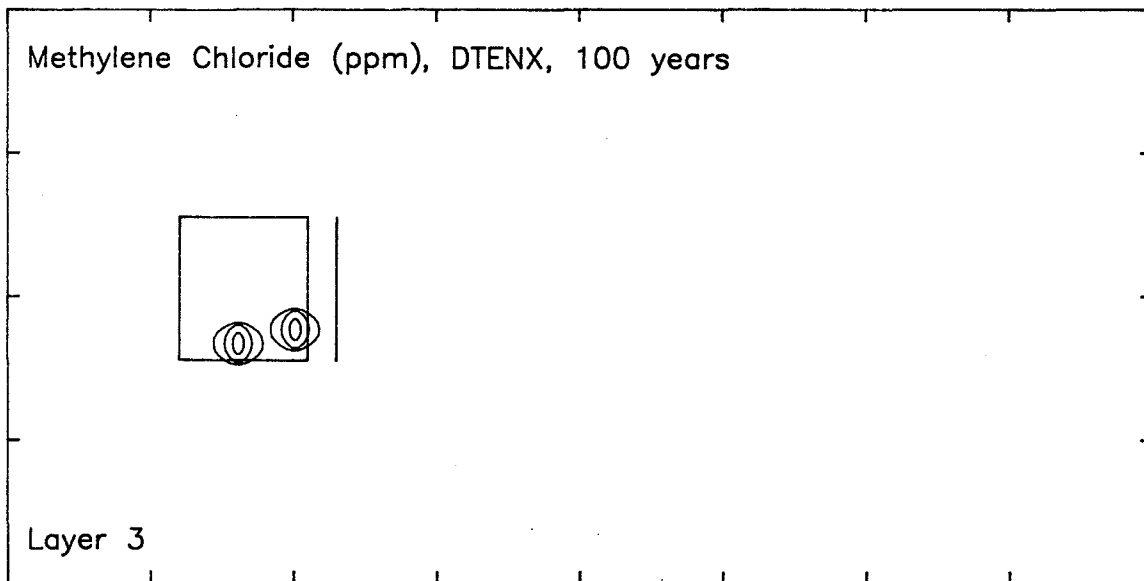
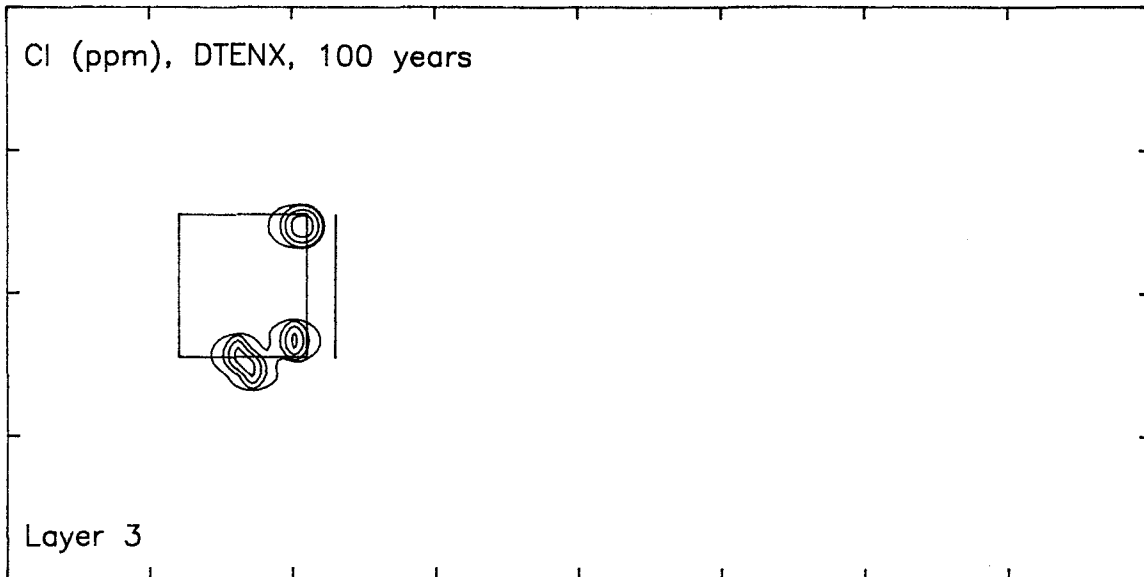

0 500 1000 ft

A horizontal scale bar is located below the two contour plots. It is marked with '0' at the left end, '500' at the midpoint, and '1000 ft' at the right end. The bar is a simple line with vertical tick marks at each of these points.

Steady-state head distribution predicted by PLASM, E scenario, 3-foot liner design. Contour interval, 2 feet.
Almost no particles migrated from the landfill nodes to the underlying layers.

Head, Layer 1, ETHREQ, Clay/till 20 feet thick

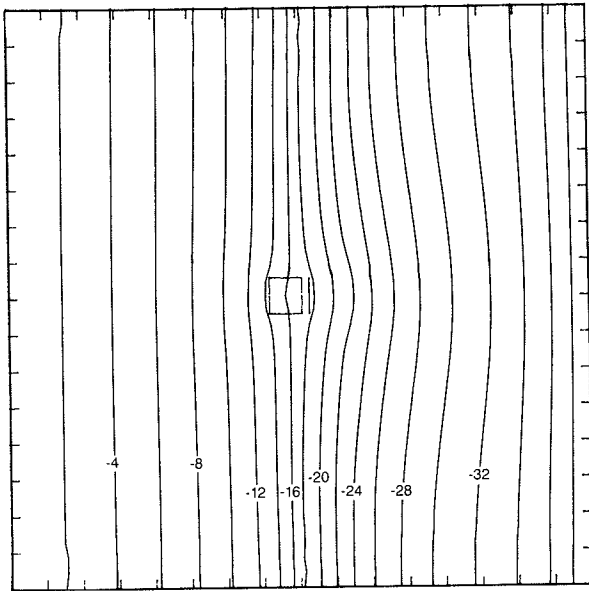

Head, Layer 2, ETHREQ, Clay/till 15 feet thick

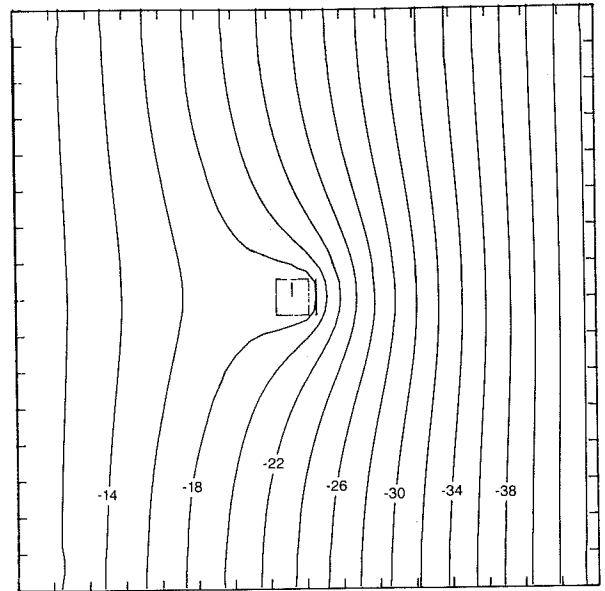

Head, Layer 3, ETHREQ, Clay/till 15 feet thick

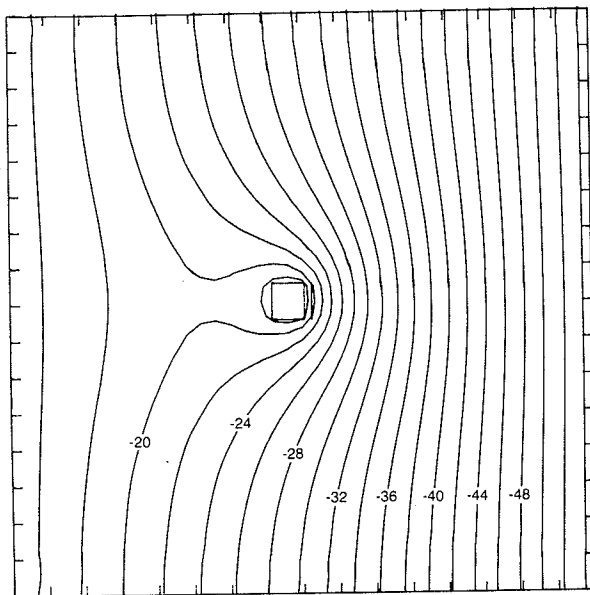

0 2000 4000 ft

Steady-state head distribution predicted by PLASM, F scenario, 10-foot liner design. Contour interval, 2 feet.
Almost no particles migrated from the landfill nodes to the underlying layers.

Head, Layer 1, FTENX, Clay/till 20 feet thick

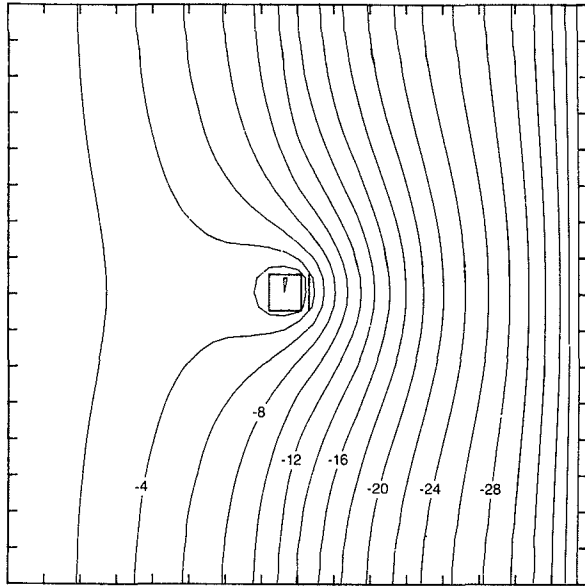

Head, Layer 2, FTENX, Shale 15 feet thick

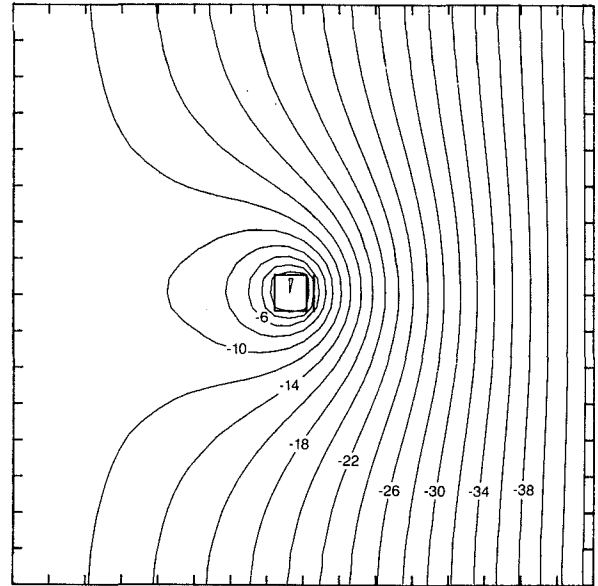

Head, Layer 3, FTENX, Shale 15 feet thick

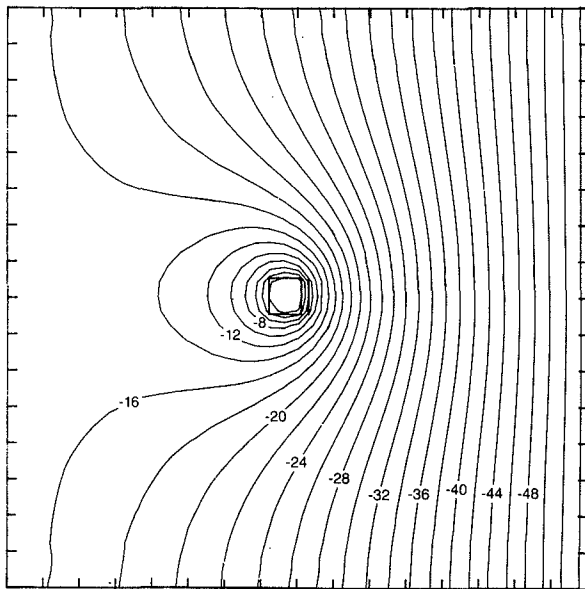

0 2000 4000 ft

Chloride concentrations, layers 2 and 3, G scenario, 3-foot liner design. Simulated time, 100 years; contour interval varies; concentration is in ppm. No aquifer is included in this scenario. Few particles migrated from the landfill nodes to the nodes representing the underlying materials. Chloride distributions for the E and F scenarios are similar.

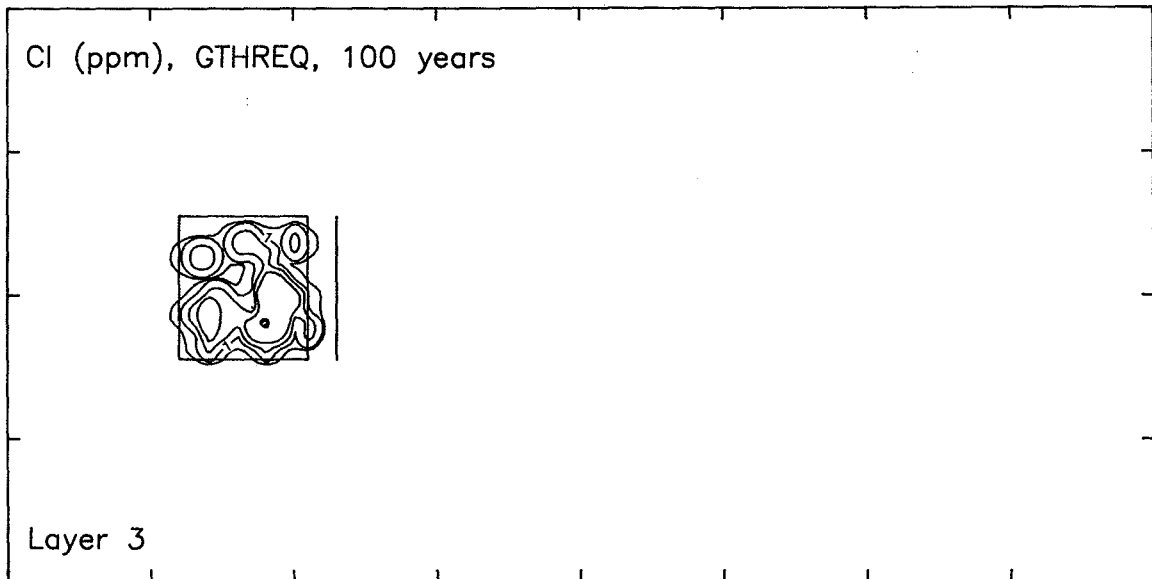
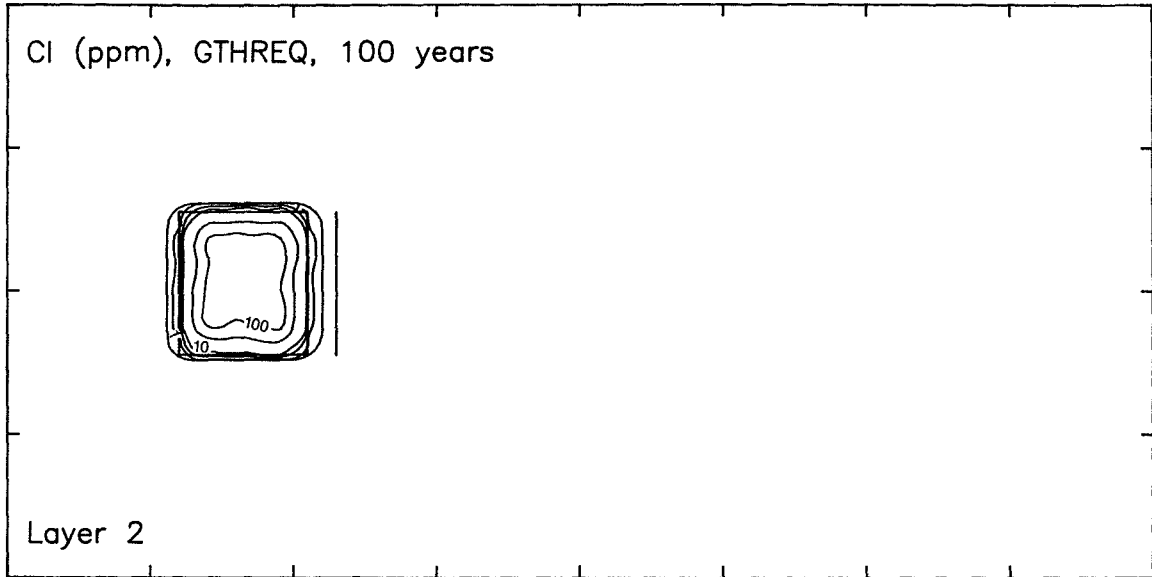

0 500 1000 ft