



The ephemeral cathedral of Créteil : a 350m² lightweight structure made of a GFRP composite gridshell

Lionel Du Peloux, Jean-François Caron, Frédéric Tayeb, Olivier Baverel

► To cite this version:

Lionel Du Peloux, Jean-François Caron, Frédéric Tayeb, Olivier Baverel. The ephemeral cathedral of Créteil : a 350m² lightweight structure made of a GFRP composite gridshell. 19èmes Journées Nationales sur les Composites, Jun 2015, Villeurbanne, France. 2015, Proceedings of the "19èmes Journées Nationales sur les Composites". <<http://jnc2015.sciencesconf.org/>>. <hal-01199039>

HAL Id: hal-01199039

<https://hal.archives-ouvertes.fr/hal-01199039>

Submitted on 18 Sep 2015

HAL is a multi-disciplinary open access archive for the deposit and dissemination of scientific research documents, whether they are published or not. The documents may come from teaching and research institutions in France or abroad, or from public or private research centers.

L'archive ouverte pluridisciplinaire **HAL**, est destinée au dépôt et à la diffusion de documents scientifiques de niveau recherche, publiés ou non, émanant des établissements d'enseignement et de recherche français ou étrangers, des laboratoires publics ou privés.

La cathédrale éphémère de Créteil : une couverture ultra légère de 350m² faite d'une résille de tubes composites en GFRP

The ephemeral cathedral of Créteil : a 350m² lightweight structure made of a GFRP composite gridshell

L. du Peloux^{1,2}, J-F. Caron², F. Tayeb², O. Baverel²

1 : T/E/S/S atelier d'ingénierie
7 cité Paradis, 75010, Paris
e-mail : lionel.dupeloux@gmail.com

2 : MSA, UMR Navier
Ecole des Ponts ParisTech
6/8 avenue Blaise Pascal, 77455, Marne la Vallée
e-mail : caron@enpc.fr

Résumé

Le diocèse du Val de Marne a entrepris la rénovation de la cathédrale Notre Dame de Créteil. Pour la durée des travaux, une structure temporaire de type gridshell en GFRP – Glass Fibre Reinforced Polymer – qui permet d'assurer la continuité des célébrations religieuses, a été réalisée par le bureau d'études T/E/S/S et le laboratoire Navier sur la base d'une expérience antérieure réussie [1]. Cet article présente et détaille la conception et la construction de ce bâtiment (Figure 1) en place depuis 2 ans. Ce prototype de grande ampleur, construit par les paroissiens eux-mêmes [2], constitue une première dans le secteur de la construction qui reste encore très fermé à l'utilisation des matériaux non traditionnels, en particulier lorsqu'il s'agit d'applications structurelles.

Abstract

The Ephemeral Cathedral of Créteil (Paris, France) is a gridshell structure made of composite materials. Built in 2013, this religious edifice of 350m² is a temporary church meant to gather the parishioners during the two-years renovation of their permanent cathedral. This large-scale prototype (Figure 1) represents a first in the building industry, which still shows excessive apprehension for the use of non-traditional materials such as composites, especially when it comes to structural applications. Based on a previous successful experience [1] the gridshell was prefabricated and erected [2] by the parishioners themselves.

Mots Clés: composite GFRP, gridshell élastique, structure légère, mise en forme

Keywords: GFRP composite, elastic gridshell, lightweight structure, active bending



Fig. 1 Interior view of the *Ephemeral Cathedral* in Paris

1 Introduction

The inventiveness of the gridshell concept is commonly attributed to Frei Otto, a German architect who devoted much time to gridshells. In 1975 he achieved the famous *Mannheim Multihalle* [3], a wooden shell of 7500m², in collaboration with the engineer Edmund Happold (Arup).

Literally, the word "*gridshell*" refers to grids behaving like shells: from a mechanical point of view that means stresses acting on the structure are mainly transmitted through compression and traction. These structures can cross large-span with very little material. Here, the whole structures spans 17x29 meters and weights only 5kg/m².

However, according to the historic evolution of the concept, characterizing a gridshell as the combination of a structural concept (a grid behaving like a shell) and a specific construction process (using the bending flexibility of the material) seems to be more accurate. The Mannheim project (in which a wooden regular and planar grid, lacking shear stiffness, is elastically deformed up to a targeted shape with the help of stays, and then braced and covered) is regarded as the starting point of this new concept.

This type of gridshell, known as *elastic gridshell*, offers a very elegant manner to materialize freeform shapes from an initially flat and regular grid, which obviously has many practical benefits: planar geometry, standard connexion nodes, standard profiles, etc.

After a brief description of the structure the paper gives an insight on the field of elastic gridshells and discusses the benefits of composite materials in such structures. The overall design process employed to go from the 3D shape designed by the architect to a fully structural shell is then explained. Finally, complexities brought by connections are highlighted and solutions are presented.

2 Building Overview

2.1 Architectural considerations

The generation of the form was driven by two objectives that of providing a variety of appropriate internal spaces within which the community could assemble, and externally to be a welcoming and visually interesting form. The form gathers under the same roof a religious space with a circular arrangement and an area for more informal gatherings after ceremonies (Figure 3).

The building can accommodate up to 500 people and complies with all the required performances for such a building: structural stiffness, fire safety, waterproofness, lightning, thermal comfort, etc.

2.2 Technical description

This gridshell structure is made of long glass-fiber tubes (Ø42mm, Figure 2a) pinned together with scaffold swivel couplers. The structural members of the grid, all of different length, are built from one, two or three composite tubes connected with steel sleeves. Tubes length is restrained to 12m so standard trucks can deliver them. The tubes are organized in three layers. The first two layers are placed perpendicularly on the ground. They form the "quadrangular primary grid". The distance between the tubes of these two layers is constant so the grid is regular. This primary grid is elastically deformed to obtain the final shape. The third layer of tubes acts as bracing. It gives the structure a shell behavior. Those tubes are fixed to the primary grid once it has been shaped.



Fig. 2 GFRP tubes, steel door, grid, PVC coated fabric

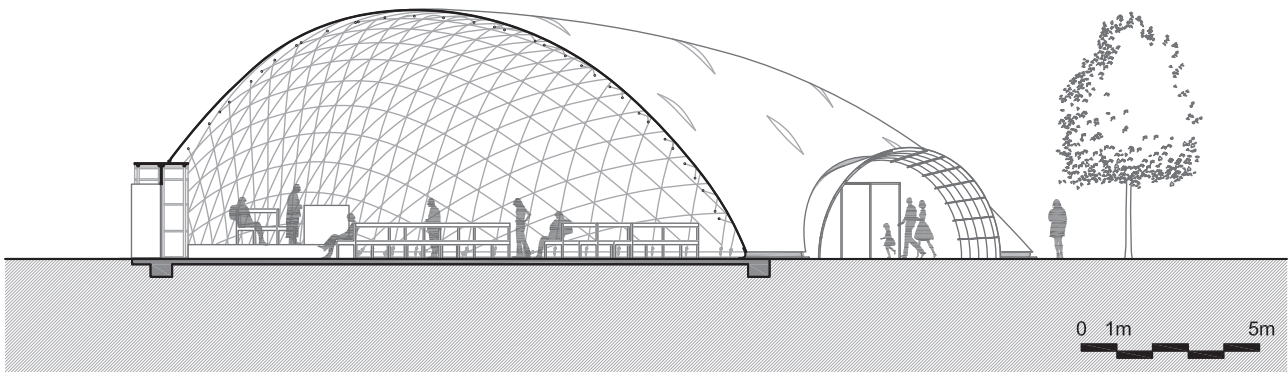

Fig. 3 Interior view of the Ephemeral Cathedral in Paris

The structure is anchored to a concrete strip footing with a special steel system, which ensures the transit of loads from the composite structure to the ground. A similar system enables to fix the structure to the doors.

A PVC coated fabric (Figure 2d), tailor patterned, covers the structure. It includes transparent strips that bring daylight inside. The fabric is stretched on a devoted peripheral edge beam with a double lacing system (halyard and strap, Figure 2b). At the ground, the lacing edge beam is made of a bent composite rod nailed regularly to the concrete slab. At the doors, it is made of a steel arch welded to the doorframes (Figure 2c). The membrane is waterproof and as a continuous membrane has no joints except at the perimeter. At the perimeter a continuous strip of membrane is prefixed to the internal face of the membrane and fixed to the ground slab. At the doors, the flexible strip is riveted to the doorframes.

2.3 Cost

The overall cost of the project is 500k\$, about 30% more than a standard tent of the same size that would have been rented for 2 years.

3 Gridshells

3.1 Recent projects

More recently, with the development of numerical tools, two new projects saw the light : the wooden gridshells of Downland in 2002 [4] and the Savill one in 2006 [5]. The principles of these projects are similar to Mannheim one but new constructive methods are used. In 2000 Shigeru Ban innovates shifting from wood materials to cardboard for the Japan Pavilion, in Hannover [6].

3.2 Recent developments

Based on this groundwork, the Navier laboratory has developed a research program on gridshells for the last decade, focusing on both the use of new materials and the development of more efficient numerical methods [7]. These developments have been validated by the construction of two prototypes



Fig. 4 Prototypes 1 & 2, Solidays 2011



Fig. 5 Erection of the primary grid by two cranes

(Figures 4a and 4b) whose areas were about 150 m².

In 2011, the laboratory used its expert knowledge for a large-scale project [8], the forum of the Solidays festival (Figure 4c). This achievement, built by voluntary workers, has been the first composite material gridshell to house public.

In 2012, the context is favorable for a new achievement named "*Temporary Cathedral of Créteil*". Although this gridshell has an area very similar to the Solidays one, the project raised new challenges, in particular the challenge of reliability. Indeed, its period of use is at least two years. Additionally, the skills coming from T/E/S/S company made possible important developments such as for doors, lacing edge beam, anchorages and sleeves.

Unlike the two first prototypes, the gridshells built for Solidays and at Créteil are based on a new approach regarding shape-structure relationship. Indeed, thanks to a numerical tool performing the compass method, the geometry of the object is no longer defined as the reversal of a hanging net – in this case, only the flat geometry could be mastered [9] – but now the flat geometry is straight deduced from the one proposed by the architect. This new approach opens up new architectural horizons, making possible the exploration of new shapes for gridshells.

3.3 Gridshell in composite material

The gridshells built in composite material, being at the heart of this paper, are consistent with the framework defined previously, that is to say :

3.3.1 Structural Typology

Their mechanical behaviour is very similar to the one of real shells even if the material is discrete and located in a grid more or less open. In spite of that, gridshells benefit from the same advantages as the ones showed by an eggshell : they can cross large span using a low amount of material. Their stiffness is mainly linked to their double-curved shape.

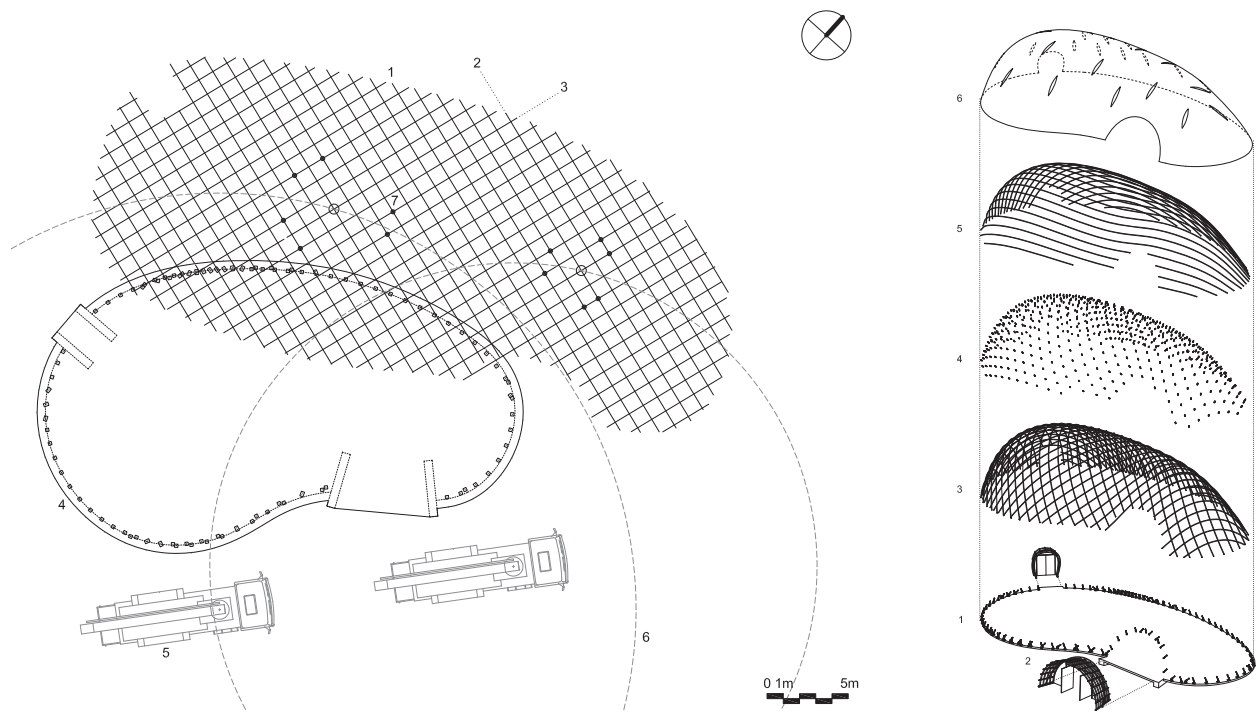

Fig. 6 Erection plan and construction stages

3.3.2 Material Flexibility for Structural Rigidity

In this field of application, composite materials like glass fibre reinforced polymer (GFRP) could favourably replace wood, where both resistance and bending ability of the material is sought [10]. The stiffness of the structure does not derive from the intrinsic material rigidity but principally from its geometric curvature. Ideally, the composite profiles are produced by pultrusion, an economic continuous moulded process. The standardization of the process guaranties very stable material and mechanical properties. It frees designers from the painful problematic of wood joining and wood durability. The characterization of this material is presented further in the paper.

3.3.3 Erection Process

Usually, the grid morphology is not trivial and leads to design numerous costly and complex joints. To overcome this issue, an original and innovative erection process was developed that takes advantage of the flexibility inherent to slender elements. A regular planar grid made of long continuous linear members is built on the ground (Figure 6a). The elements are pinned together so the grid has no in-plane shear stiffness and can accommodate large-scale deformations during erection. Then, the grid is bent elastically to its final shape (Figure 5). Finally, the grid is frozen in the desired shape with a third layer of bracing members (Figure 6b) and the structure becomes a shell.

4 Design Process

4.1 Overall design process

The goal of the design process is to identify a gridshell structure that works and respects as faithfully as possible the architectural project – a shape and a program. It represents “the path from shape to structure”. Its progress, sequential and iterative, revolves around three major stages: shape, mesh and structure. It is not trivial to go through this complex process. Indeed, for each step, the method, the tool, the criteria, that offers both a sufficient explorative richness to find out enough candidate solutions, and the means to evaluate and compare the suitability of those solutions, have to be found.

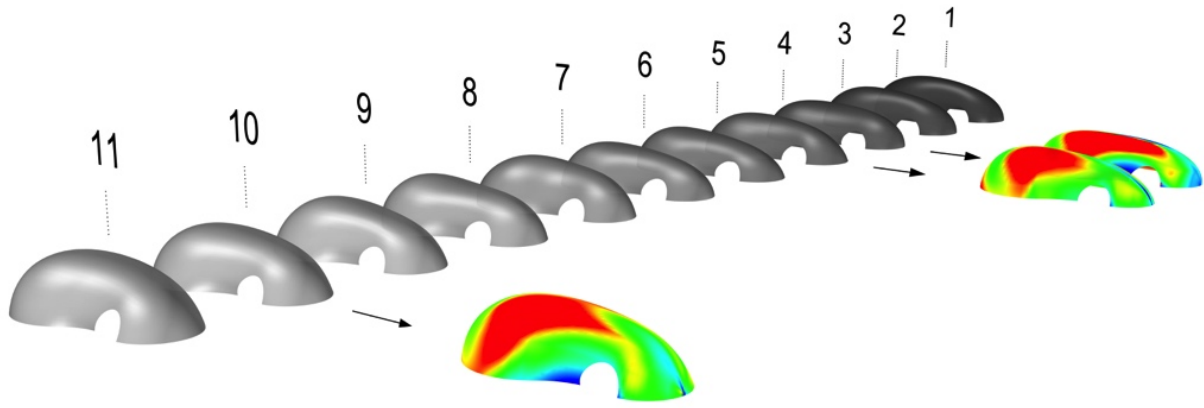

Fig. 7 Evaluating the mechanical potential of shapes regarding principal curvatures

4.2 3D modelling of the intended shape

The first step of the process consists in building a precise geometric model from the sketch of the architect and to evaluate its mechanical potential (Figure 7). At this stage, the goal is to estimate the probability a given shape would lead to the generation of a structurally feasible gridshell.

Stresses in the grid are mainly due to the bending of the profiles. They derive directly from their geometric curvature. Thus, the principal curvatures of the surface – because they give a qualitative measurement of the local curvature of any curve drawn on a surface – are relevant indicators to evaluate the stress rate of a grid laying on it. Particularly, one should ensure the following condition is satisfied everywhere, where r is the pipe's outer radius, R_{min} is the minimum principal radius, E is the flexural modulus, $\sigma_{k,flex}$ the characteristic flexural strength and γ_t the long-term partial coefficient of material resistance :

$$E = \frac{r}{R_{min}} < \frac{\sigma_{k,flex}}{\gamma_t} \quad (1)$$

Ideally, the shape is controlled by few key parameters. Thus, it can be adapted and optimized through an iterative process, towards this criterion.

4.3 Mesh from the compass method

During the second step, the candidate surface is meshed and the mechanical potential of the resulting grid is evaluated. At this stage, we try to estimate the probability a given mesh could lead to the generation of a viable gridshell structure. Simultaneously, meshes are compared according to their architectural relevance.

This time, the geometric curvature of the polylines drawn on the surface is the criterion to characterize the mechanical potential of the grid. In particular, one should ensure the following condition is satisfied everywhere, where R_{spline} is the spline's local curvature radius :

$$E = \frac{r}{R_{spline}} < \frac{\sigma_{k,flex}}{\gamma_t} \quad (2)$$

The mesh is obtained by the compass method, described in [11], which develops a regularly spaced grid on a surface from two secant directrix. For a given shape there are an infinite number of meshes. The aim is to identify at least one grid, suitable towards architectural and structural criteria. The

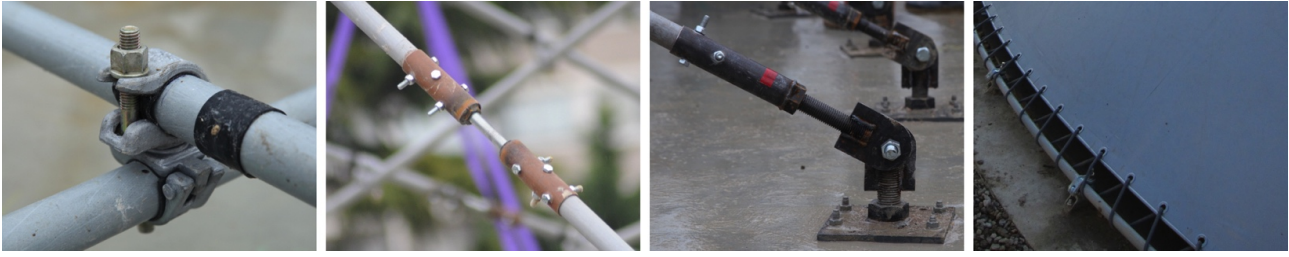

Fig. 8 Swivel coupler, steel sleeve, ground anchorage and lacing edge beam

laboratory tried various numerical methods to generate such grids [12]. Here, a specific software [13], developed for rhino & grasshopper, allows generating this kind of mesh on any NURBS surface.

4.4 Formfinding and bending prestress

From now on, the initial form has been optimized and promising meshes for the materialization of the future gridshell have been identified. However, they do not take account of any true mechanical reality, because only geometric rules have led to their generation. The formfinding step consists precisely in finding the geometry of the grid at mechanical equilibrium, and the corresponding permanent bending stresses. The calculations, performed numerically thanks to a dynamic relaxation algorithm with kinetic damping [14], is composed of the following steps:

1. The grid is bent by a set of applied displacements from rest to compass position
2. The grid is then relaxed through its mechanical equilibrium
3. Bending stresses of the triangulation are calculated relative to the relaxed geometry
4. Geometry and bending stresses of the triangulation are reinjected in the model

Two analysis models are built during this process to study the structure with or without bracing tubes. Note that the algorithm has been improved to take account for the eccentricity due to connections [15].

4.5 Structural analysis

A full structural analysis is performed on the gridshell, using the two mechanical models created previously during the formfinding stage. The non-braced model is used to check the grid's behavior during the construction stages. In particular, it must be verified that the primary grid - the one with no triangulation tubes - has no risk of buckling, both for obvious safety reasons and to ensure the accuracy of the final geometry. Indeed, the more the form is likely to buckle, the more it can be triangulated in a buckled geometry different to the targeted geometry. The model with the triangulated grid is used to confirm the gridshell complies with all the structural requirements during its lifetime. Its behavior under standard loadings is evaluated.

5 Construction details

In this project, one can identify 4 major structural details : the swivel coupler for connecting composite tubes to assemble the grid (Figure 8a); the steel sleeve for connecting several composite tubes to make long members from initially short piece of tubes (Figure 8b); ground anchorages for fixing the structure to the concrete slab (Figure 8c) and the lacing edge beam of the fabric (Figure 8d). Note that the tricky issue of connecting steel and composite parts is solved in a similar way through sleeve and anchorage details.

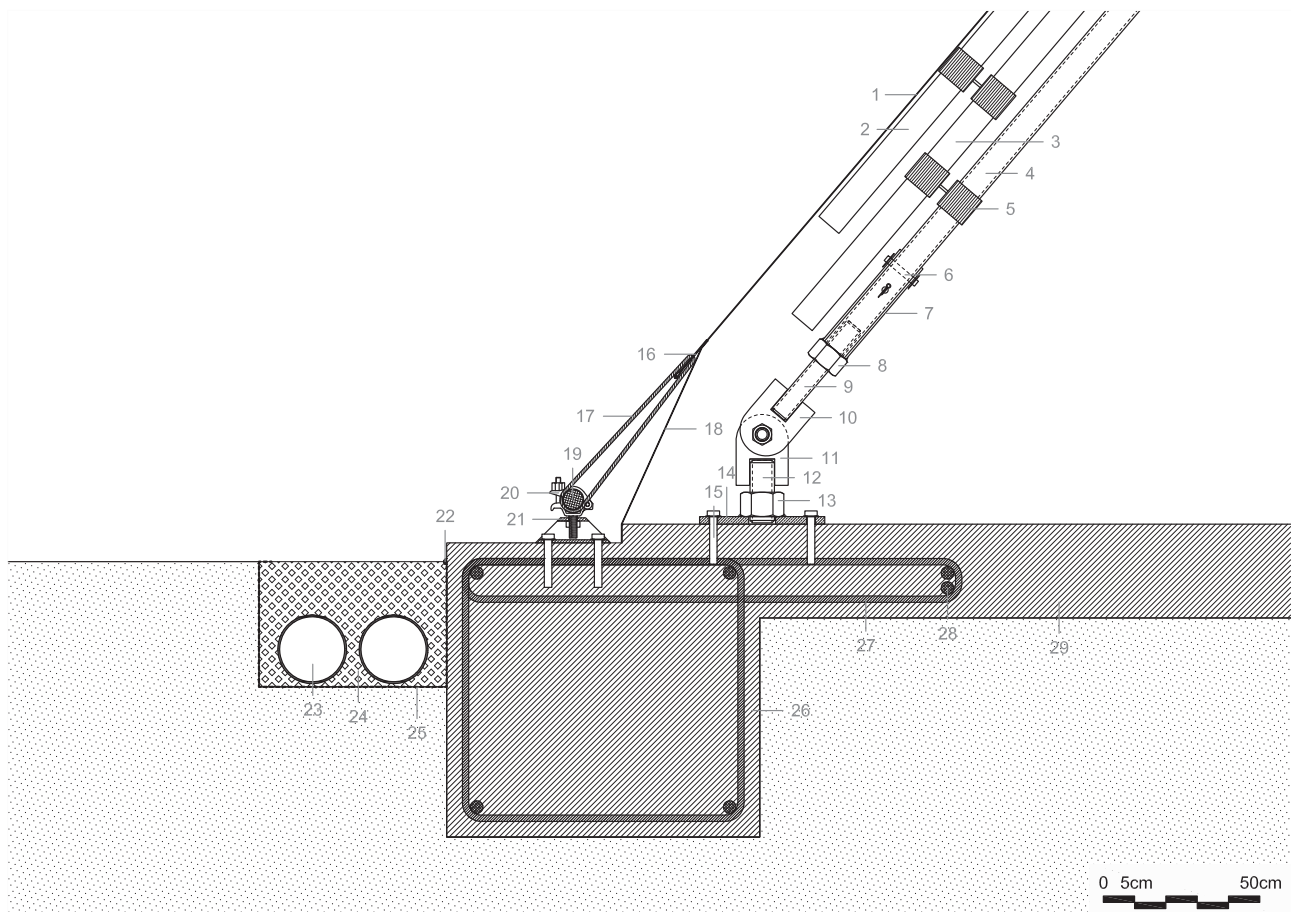

Fig. 9 Section on the footer

6 Codes for composite materials

Beyond the technical difficulties related to both design and structural analysis of the shell, the regulatory framework was a vital issue for the project's success. Because it was the first time a structure of this kind would host regularly a large number of people in a long-term period, the question of its reliability over time was a major issue. To be built the gridshell had to comply with existing standards, which do not take into account such an innovative edifice, all in composite material. The strategy adopted to bypass this obstacle consisted in making the most of the existing regulatory framework to justify the compliance of a structure that would not, at first sight, be taken into account by standards that does not include composite materials. As far as possible, the design was led in compliance with the Eurocodes, where the structural design is made according to limit states under normalized loadings (self-weight, snow, wind, etc.). Despite the Eurocodes do not directly take into account composite materials, they propose some probabilistic methods to introduce new materials (Annexe D). As far as possible, the mechanical properties of the GFRP pipe were determined by tests in conformance with these methods. Otherwise, values were taken according to the Eurocomp [16]. In some cases, as the sleeve, the design of the construction details has also benefited from this approach.

6.1 Flexural strength of the tubes

The characteristic flexural strength ($\sigma_{k,flex}$) of the GFRP tube has a critical impact on the structure's reliability because in this particular application stresses in the tubes are mainly due to bending. Thus, it was important to confirm the manufacturer's value by assays. Three-point flexural tests were led with and without connexions (tightening torque set to 20Nm) to determine the characteristic strength according to the protocol of the Eurocode (Annex D) :

$$\sigma_{k,flex} = \bar{\sigma}(1 - k_n \sigma_x) \quad (3)$$

For five tests, the factor $k_{n,5\%}$ is 1.80, assuming a normal distribution. One can note that the connections scatter the results more (Table 1). Finally, the manufacturer value of 400MPa (ASTM D790) was confirmed and retained for further calculations.

Connections	σ_1	σ_2	σ_3	σ_4	σ_5	$\sigma_{k,flex}$
Without	456	441	445	460	477	430
With	444	478	434	479	427	408

Tab. 1 Three-point flexural tests of the GFRP tubes (results in MPa)

6.2 Partial safety factors

The partial coefficients of material resistance used in the project are calculated according to the Eurocomp (Table 2). The short-term coefficient proposed in the Eurocomp ($\gamma_{st} = 1.3$) was raised to consider the critical stage of erection, where the deformations are not controlled accurately.

Impact	Partial coefficient	Design flexural strength
Short-term	$\gamma_{st} = 2.0$	200 MPa
Long-term	$\gamma_{st} = 3.0$	133 MPa

Tab. 2 Short-term and long-term values for material resistance.

Note that designers should take care about long-term effects in permanently loaded pultruded composite materials subjected to creeping and relaxation [17]. Here, it is reflected in a high partial coefficient for long-term effects.

Conclusions

This paper has presented the different steps for the design of a gridshell in composite material : a Temporary Cathedral at Créteil, in Paris suburb, in 2013. The first step was the optimization of the shape in order to avoid local concentrations of curvature. The second step showed a tool to automatically mesh a surface using the compass method. With this tool, the orientation of the mesh is studied according to structural and architectural criterions. The last steps showed the structural analysis of the gridshell and how to get the as-built geometry from the analysis model. Architecturally, the structure offers a very interesting space where the textual richness of the tubes against the membrane accentuates the reading of the complex curved surfaces.

This project demonstrates that gridshells in composite material are suitable for constructing freeform buildings. However, the long-term behavior of these materials needs to be better characterized to extend their lifespan.

At the moment, further developments are conducted by the laboratory to take account for torsional effects and non axisymmetric sections in such structures, as it is studied in [18].

Acknowledgements

The authors would like to thank the Catholic Church of Créteil for their trust and their courage, which permitted to get into this ambitious and successful project. They also want to greet the engineers from T/E/S/S, which have developed this challenging project during 18th months. They also thank the firm Viry for the supervision of construction works, including the delicate erection stage.

References

- [1] Lionel du Peloux and Frédéric Tayeb. Construction of the Forum Solidays, 2011. URL <https://www.youtube.com/watch?v=24LLfcVIZWw>.
- [2] Lionel du Peloux. Construction of the Ephemeral Cathedral of Créteil, 2013. URL <http://vimeo.com/59726330>.
- [3] Edmund Happold and W I Liddell. Timber lattice roof for the Mannheim Bundesgartenschau. *The structural engineer*, 53(3):99–135, 1975.
- [4] Richard Harris, John Romer, Oliver Kelly, and Stephen Johnson. Design and construction of the Downland Gridshell. *Building research and information*, 31(6):427–454, 2003.
- [5] Richard Harris, Steve Haskins, and Jonathan Roynon. The Savill Garden gridshell : Design and construction. *The Structural Engineer*, 86(17):27–34, 2008.
- [6] Matilda McQuaid and Frei Otto. The Japanese pavilion. In Phaidon, editor, *Shigeru Ban*, pages 8–11. 2006.
- [7] Cyril Douthe. *Etude de structures élancées précontraintes en matériaux composites : application à la conception des gridshells*. PhD thesis, Université Paris Est, 2007.
- [8] Olivier Baverel, Jean François Caron, Frederic Tayeb, and Lionel du Peloux. Gridshells in composite materials : construction of a 300 m2 forum for the solidays’ festival in Paris. *Structural Engineering International*, 22(3):408–414, 2012.
- [9] Bill Addis. ‘Toys that save millions’ - A history of using physical models in structural design. *The Structural Engineer*, 91(4):12–27, 2013.
- [10] Cyril Douthe, Jean-François Caron, and Olivier Baverel. Gridshell structures in glass fibre reinforced polymers. *Construction and Building Materials*, 24(9):1580–1589, 2010.
- [11] Frei Otto, Eda Schauer, Jürgen Hennicke, and Takeshi Hasegawa. *IL10 Grid Shells*. 1974.
- [12] Lina Bouhaya, Olivier Baverel, and Jean-François Caron. Mapping two-way continuous elastic grid on an imposed surface : application to grid shells. In *IASS 2009*, pages 989–998, Valencia, Spain, 2009.
- [13] Lionel du Peloux, Olivier Baverel, Jean-François Caron, and Frédéric Tayeb. From shape to shell : a design tool to materialize freeform shapes using gridshell structures. In *Design Modelling Symposium*, 2011.
- [14] Michael Barnes. Applications of dynamic relaxation to the design and analysis of cable, membrane and pneumatic structures. In *International Conference on Space Structures*, 1975.
- [15] Cyril Douthe, Olivier Baverel, and Jean-François Caron. Formfinding of a grid shell in composite materials. *Journal of the IASS*, 47:53–62, 2006.
- [16] John L. Clarke. *structural design of polymer composites - eurocomp design code and handbook*. 2003.
- [17] Natalia Kotelnikova-Weiler. *Optimisation mécanique et énergétique d’enveloppes en matériaux composites pour les bâtiments*. PhD thesis, Université Paris-Est, 2012.
- [18] Michael Barnes, Sigrid Adriaenssens, and Meghan Krupka. A novel torsion/bending element for dynamic relaxation modeling. *Computers & Structures*, 119:60–67, April 2013.