

Montana Tech Library Digital Commons @ Montana Tech

General Engineering

Faculty Scholarship

12-4-2009

Fabrication methods for creating flexible polymer substrate sensor tags

Jack L. Skinner
Montana Tech

Harvey Ho
Sandia National Labs

Follow this and additional works at: http://digitalcommons.mtech.edu/gen_engr

 Part of the [Nanoscience and Nanotechnology Commons](#)

Recommended Citation

Skinner, Jack L. and Ho, Harvey, "Fabrication methods for creating flexible polymer substrate sensor tags" (2009). *General Engineering*. Paper 6.
http://digitalcommons.mtech.edu/gen_engr/6

This Article is brought to you for free and open access by the Faculty Scholarship at Digital Commons @ Montana Tech. It has been accepted for inclusion in General Engineering by an authorized administrator of Digital Commons @ Montana Tech. For more information, please contact ccote@mtech.edu.

Fabrication methods for creating flexible polymer substrate sensor tags

Abstract

The authors describe the design, fabrication, and testing of a passive wireless sensor platform utilizing low-cost commercial surface acoustic wave filters and sensors. Polyimide and polyethylene terephthalate sheets are used as substrates to create a flexible sensor tag that can be applied to curved surfaces. A microfabricated antenna is integrated on the substrate in order to create a compact form factor. The sensor tags are fabricated using 315 MHz surface acoustic wave filters and photodiodes and tested with the aid of a fiber-coupled tungsten lamp. Microwave energy transmitted from a network analyzer is used to interrogate the sensor tag. Due to an electrical impedance mismatch at the SAW filter and sensor, energy is reflected at the sensor load and reradiated from the integrated antenna. By selecting sensors that change electrical impedance based on environmental conditions, the sensor state can be inferred through measurement of the reflected energy profile. Testing has shown that a calibrated system utilizing this type of sensor tag can detect distinct light levels wireless and passively. The authors also demonstrate simultaneous operation of two tags with different center passbands that detects light. Ranging tests show that the sensor tags can operate at a distance of at least 3.6 m.

Publisher's Statement

Copyright (2009) American Vacuum Society. This article may be downloaded for personal use only. Any other use requires prior permission of the author(s) and the American Vacuum Society. The following article appeared in: Journal of Vacuum Science and Technology B 27(6), Nov/Dec 2009. DOI: 10.1116/1.3258142. This article may also be found [here](#).

Fabrication methods for creating flexible polymer substrate sensor tags

Harvey Ho and Jack L. Skinner^{a)}

Sandia National Laboratories, Livermore, California 94551

(Received 15 July 2009; accepted 8 October 2009; published 4 December 2009)

The authors describe the design, fabrication, and testing of a passive wireless sensor platform utilizing low-cost commercial surface acoustic wave (SAW) filters and sensors. Polyimide and polyethylene terephthalate sheets are used as substrates to create a flexible sensor tag that can be applied to curved surfaces. A microfabricated antenna is integrated on the substrate in order to create a compact form factor. The sensor tags are fabricated using 315 MHz SAW filters and photodiodes and tested with the aid of a fiber-coupled tungsten lamp. Microwave energy transmitted from a network analyzer is used to interrogate the sensor tag. Due to an electrical impedance mismatch at the SAW filter and sensor, energy is reflected at the sensor load and reradiated from the integrated antenna. By selecting sensors that change electrical impedance based on environmental conditions, the sensor state can be inferred through measurement of the reflected energy profile. Testing has shown that a calibrated system utilizing this type of sensor tag can detect distinct light levels wireless and passively. The authors also demonstrate simultaneous operation of two tags with different center passbands that detects light. Ranging tests show that the sensor tags can operate at a distance of at least 3.6 m. © 2009 American Vacuum Society. [DOI: 10.1116/1.3258142]

I. INTRODUCTION

Wireless sensor networks are of great interest due to their potential at providing vast amounts of environmental data in military, industrial, residential, and commercial applications. A significant drawback of modern sensors is the requirement of onboard power sources. Efforts have been made to reduce the power draw of the electronics used on sensor nodes;^{1,2} however, the finite energy supply of batteries requires sensor nodes to be maintained at regular intervals, increasing cost. Work has been done to create sensor nodes, which makes use of power scavenging technologies such as piezoelectric generators or photovoltaics in order to replace or augment battery operation. However, unpredictable and uncontrollable environmental conditions can adversely affect the reliability of a sensor node by limiting the availability of scavenged power.

We present a low-profile wireless sensor node that is capable of operating passively, requiring power only from an incident microwave interrogation pulse. Much like a passive radio frequency identification tag, a surface acoustic wave (SAW) based sensor tag can remain dormant until data are required. When a reading is necessary, an active interrogation unit pings the sensor tag with a pulse of microwave energy and measures the reflected signal. The sensor tag itself is comprised of three main components: a resonant antenna, a SAW filter, and an impedance-changing sensor. The antenna serves to collect and send microwave energy to and from the SAW filter. Energy from the antenna is propagated to the SAW filter, which converts electrical energy to mechanical and vice versa. This transduction mechanism is a method to confine the response of the sensor to a narrow frequency band and allow for more sensors to operate in a given band. The sensor itself monitors the environment and

changes electrical impedance accordingly. According to transmission line theory, a mismatch in impedance between the SAW filter and the sensor will cause a portion of the interrogation signal to reflect back toward the SAW filter. The relatively high efficiency of the SAW filter allows the sensing signal to travel back toward the antenna and reradiate. Sensor state can be determined via the interrogation unit. The sensor tags themselves can stay fielded and functional for long periods of time.

Several groups investigated SAW devices to create passive sensors that can sense a wide variety of environmental conditions.³⁻⁵ Applications for this technology have started to enter the automotive market in the form of wireless tire health monitors.^{6,7} The majority of the sensors developed to date are based on rigid substrates and external antennas. We take a novel approach to SAW sensors by incorporating essential sensor components onto a flexible polymer substrate with a very small footprint (Fig. 1). Specifically, a flexible sensor is developed to sense optical (430–610 nm) light intensities and operates in the 315 MHz regime (Fig. 2). It is possible to further reduce the size of the sensor and associated antenna through the use of higher operating frequencies (Fig. 3).

II. MATERIALS AND METHODS

A. Fabrication

The sensor tag substrate is a plastic sheet made up of either polyethylene terephthalate (PET) or polyimide. The choice of using PET versus polyimide depends on the application. Polyimide offers better temperature stability but is prone to swelling in high humidity environments. The PET substrates have a glass transition temperature near 75 °C, which makes it unsuitable for application in some environments. Additionally, polyimide has a tint, while PET is opti-

^{a)}Electronic mail: jlskinn@sandia.gov

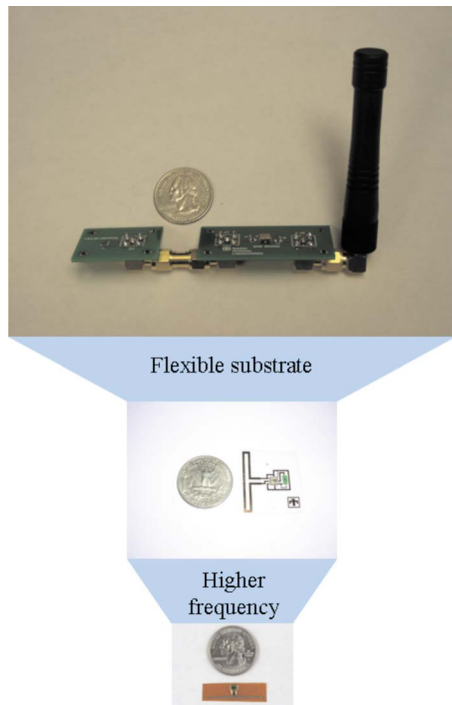

FIG. 1. (Color online) (Top) Sensor node is comprised of a sensor element, a SAW filter, and an antenna. (Middle) The size of the sensor tag is reduced by switching to a flexible substrate with an integrated antenna. (Bottom) Further reduction in size is achieved by using higher frequency components.

cally clear, which is important in certain optical sensing applications where spectral content is important. In our particular case, we use a commercial photodiode (TEMD6010FX01, Vishay) that is surface mounted onto the top of the substrate, removing the need for an optically clear plastic. Low temperature surface micromachining techniques are used to generate surface features, such as chip interconnects and bond pads for each type of plastic.^{8,9}

Figure 4 shows the fabrication steps for a passive sensor tag on a flexible substrate. The plastic is cut into the shape of a 100 mm diameter silicon *p*-type wafer for compatibility with various cleanroom tools. Sheets of 100 μm thick PET or 75 μm thick polyimide are washed with isopropyl alco-

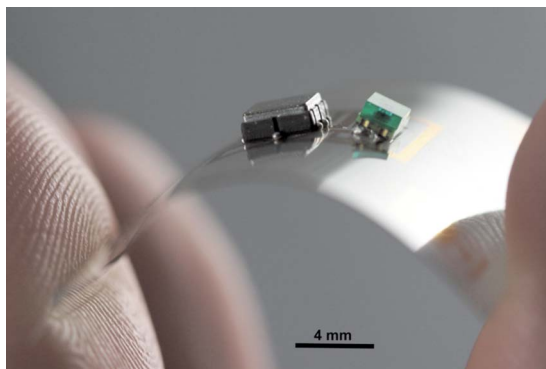

FIG. 2. (Color online) SAW based sensor tag operating at 315 MHz made of a PET substrate allows for greater flexibility and conformity to curved surfaces.

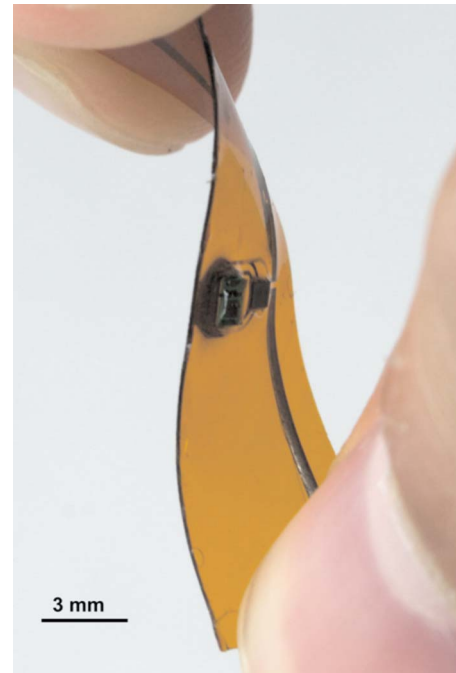

FIG. 3. (Color online) Prototype sensor tag made with 2.4 GHz components. The size of the resonant antenna scales inversely with frequency, allowing for a decrease in the antenna size over the 315 MHz SAW based sensor. Smaller components allow for even greater flexibility of the substrate.

hol, acetone, and plasma etched in 50 W of O_2 plasma for 5 min. After the cleaning process, the wafers are coated with hexamethyldisilazane primer and a 1.3 μm thick layer of Shipley 1813 photoresist using standard spin coating techniques. A low temperature bake at 65 $^\circ\text{C}$ for 5 min is used to prevent the PET from warping. Each wafer is then patterned using a contact aligner and a photomask. The wafers are placed in LDD-26W developer for 1 min to remove photoresist for subsequent metallization. A 5 min 50 W O_2 plasma clean is used to clean the surface and promote adhesion for subsequent metal deposition. Metals consisting of chrome,

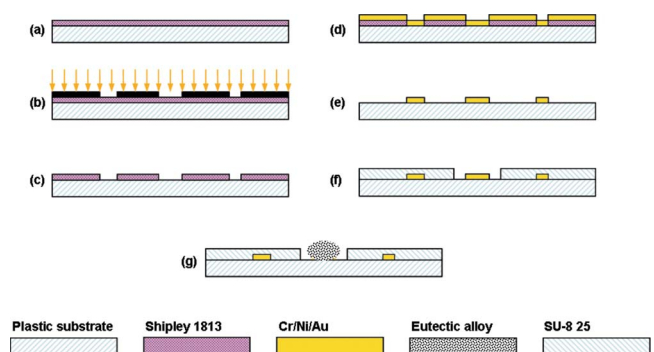

FIG. 4. (Color online) (a) Shipley 1813 (1.3 μm) is deposited using PET-compatible low temperature processing. (b) Karl Suss MA6 contact aligner is used to expose photoresist to ultraviolet light. (c) LDD-26W developer is used to remove photoresist for subsequent metallization. (d) Cr/Ni/Au (5/150/100 nm) is deposited with electron beam evaporator. (e) Lift-off in acetone defines metal traces, pads, and antenna. (f) SU-8 passivation layer is applied and patterned to define solder bump regions. (g) Eutectic alloy is selectively deposited on exposed metal through liquid metal dip.

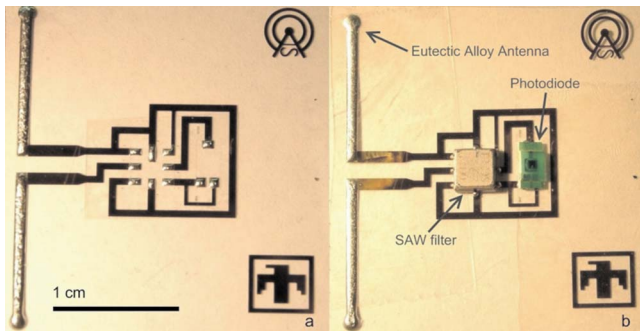

FIG. 5. (Color online) (a) SU-8 passivation layer keeps the eutectic alloy from coating regions other than the bond pads or antenna. (b) A completed tag is shown after component assembly with integrated antenna and commercial parts.

nickel, and gold with thicknesses of 5, 150, and 100 nm, respectively, are deposited using e-beam evaporation. The temperature of the evaporation process does not exceed the glass transition temperature of the PET, thus eliminating substrate warping. A lift-off process in acetone is used to remove leftover photoresist and unwanted metal from the wafer surface. A series of metal lines remains on the surface and constitutes the interconnects for the commercial surface mount chips. Another O_2 plasma treatment is performed prior to spin coating with SU8-25 (Microchem, MA) negative photoresist. In order to accommodate the temperature sensitivity of the PET, the soft baking process for SU-8 is reduced to a 65°C bake for 10 min, while the postbake is done at 65°C for 1 h. This layer of SU-8 serves as a passivation layer for the metal traces and defines the assembly sites for the surface mount chips. Openings in the SU-8 layer also determine where solder will coat the metal lines, creating bond pads and a dipole antenna.

The wafers are dipped into a mixed bath of acidic water and molten eutectic alloy to pattern solder bumps onto the bond pads. A low melting point alloy (Indalloy 117, Indium Corp.) is used for compatibility with the PET. Small amounts of hydrochloric acid are added to the mixture in order to remove oxide buildup. The bath is kept at 60°C as the tags are dipped into the alloy and withdrawn through the alloy-water interface. The water interface acts to remove alloy that is not in contact with the metal pads of the tag. Figure 5(a) shows the results of the bumping process. The integrated antenna thickness is increased from 255 nm to a maximum thickness of $\sim 160\ \mu\text{m}$ (average thickness of $\sim 130\ \mu\text{m}$) during the solder bumping process in order to create additional metal thickness to limit transmission losses. The base metal consisting of Cr/Ni/Au is very thin and inefficient when used as an antenna at 315 MHz. The additional $130\ \mu\text{m}$ of metal afforded by the eutectic alloy increases the efficiency of the system.

The bond pads of the commercial SAW filters (B376x, Epcos) and photodiodes are similarly coated with the eutectic alloy. Heat activated liquid flux is used to remove the oxide buildup on the surfaces of the tag and commercial components. The parts are manually positioned and heat

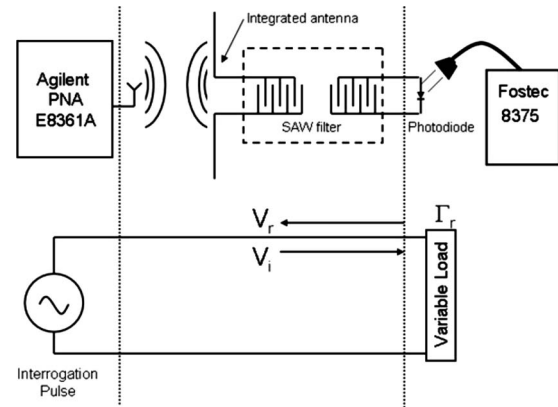

FIG. 6. (a) Network analyzer is used as an interrogation unit to both generate the ping signal and receive the reflected S_{11} signal. The wireless link can be modeled as a transmission line with a variable impedance load, which causes a varying reflection coefficient (Γ_r). (b) Analysis of the reflected signal allows the sensor state to be determined.

from a hot air gun is used to melt the solder as well as activate the flux. Figure 5(b) shows a tag after assembly with an integrated dipole antenna, SAW filter, and photodiode. The tag can be additionally passivated with epoxy to mechanically fix the commercial parts to the surface of the tag.

B. Testing

The interrogation unit used to test sensor tag performance is a network analyzer (PNA-E8361A, Agilent) operating around the 315 MHz band with a resonant dipole antenna attached to port 1. The network analyzer both generates the interrogation pulse and receives the reflected signal (in the form of S_{11}) in order to read out data from the sensor tag. A tungsten lamp (model 8375, Fostec) is used to illuminate the photodiode with various light intensities, inducing changes in impedance. In all test cases, the fiber-coupled lamp is approximately 2 mm from the surface of the diode. Figure 6 shows a model on the theory of operation of the sensor tag.

A resonant dipole antenna at 315 MHz measures 47.6 cm in length and cannot fit within the current form factor of our sensor tag. Our antennas are less efficient due to losses from the short antenna length on the tag and limits operation to short distances. In order to increase efficiency and range, we can add an extra wire length by using the eutectic alloy solder to attach an extra wire to the ends of the integrated dipole. For sensors operating in the gigahertz region or higher, it is possible to fabricate a fully resonant antenna directly on the substrate.

III. RESULTS

A. Single tag with varying light levels

Tests using a single tag include a test to determine the possible communication range of the sensor tag and a test to measure discrete levels of light. A tag augmented with an extra wire to create a resonant antenna at 315 MHz was able to operate with a distance of 3.6 m between the antenna on the network analyzer and the antenna on the sensor tag. The

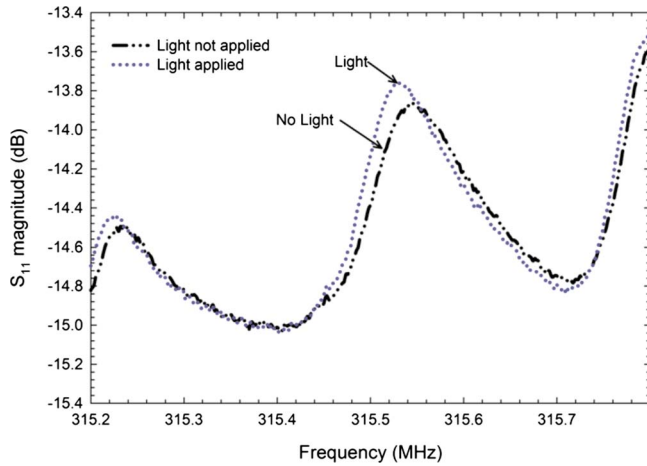

FIG. 7. (Color online) Measured S_{11} signals indicate an increased magnitude at the 315.50 MHz peak, representing illuminated conditions and decreased magnitude corresponding to decreased illumination.

sensor tag was made of PET with a nominal 315.50 MHz SAW filter. Light incident on the sensor tag was toggled between the fully off state (complete darkness) and full output power. The measured signal at the network analyzer is shown in Fig. 7. Observing the peak in the 315.50 MHz region, it is clear that the peak increases under illuminated conditions and decreases under dark conditions.

A different test was conducted using a single tag at 315.50 MHz measuring varying light levels. The test was also conducted to determine if a sensor can be operated while applied to a curved surface. Like the previous test, an extra wire length was added to increase efficiency, and the tag was applied to the surface of a 5 gal water container (Fig. 8). The minimum distance between the network analyzer antenna and the sensor tag was approximately 3 cm. Using photocurrent measurements with the tungsten lamp and the current response listed in the datasheet, we correlated the illuminance with power settings on the lamp source. The sensor tag

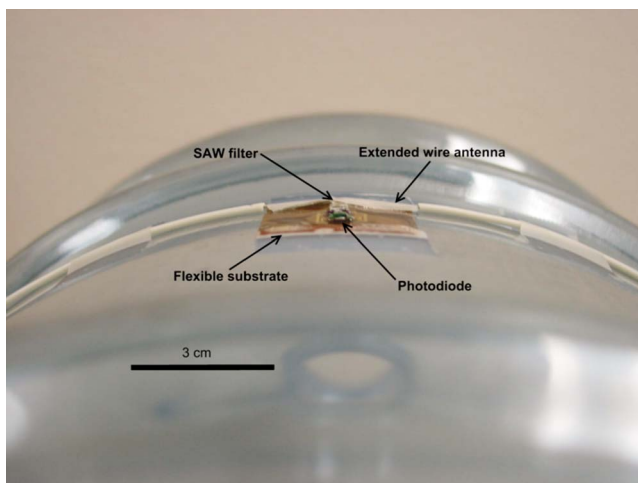

FIG. 8. (Color online) Sensor tag was fixed to the curved surface of a water container to test for functionality. The sensor was able to sense various levels of light while bent.

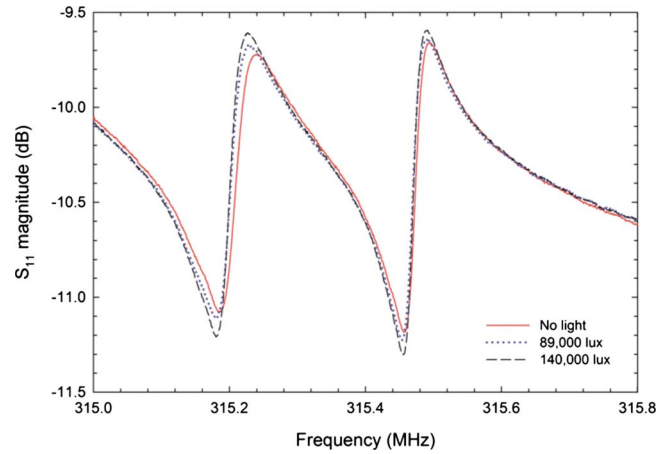

FIG. 9. (Color online) Different values of illuminance are measured using a single sensor tag loaded with a photodiode. Changing light intensity is indicated as a shift in the S_{11} magnitude and demonstrates sensor operation while affixed to the surface of a cylinder.

was subjected to the different levels of illuminance, and the response was measured at the network analyzer. The measured values in Fig. 9 indicate that lower illuminance values correspond to smaller S_{11} magnitudes.

B. Dual tags

In order to address more than one sensor, we chose to vary the center passbands of each SAW device. For larger networks, it is possible to use delay lines to give each tag a unique identifier in the time domain.¹⁰ In our tests, we use two tags with extended antennas and a center passband separation of 350 kHz to differentiate the two sensors with frequency discrimination. The first tag contained a 315.15 MHz SAW filter (B3763, Epcos), while the second tag contained a 315.50 MHz SAW filter (B3765, Epcos). The tags were placed 20 cm from the interrogating antenna and were stacked vertically with respect to each other. The test conditions were made such that light was exclusively applied to tag 1, tag 2, or neither. “ON” conditions represent the light source set to full intensity. The data from Fig. 10 indicate that the S_{11} magnitudes, corresponding to the operating frequencies of each respective tag, shift accordingly when light is exclusively applied to either tag.

IV. CONCLUSION

A passive wireless sensor platform has been fabricated and tested for sensing light conditions. The system is able to make use of inexpensive commercial electronics to create a low-profile sensor capable of conforming to curved surfaces. Sensor tags loaded with photodiodes were able to sense the presence of light in a binary fashion at a communication distance of 3.6 m. At a closer range, the sensor was able to detect discrete levels of illuminance. We also demonstrated that it is possible to operate multiple tags simultaneously through the use of frequency discrimination between individual tags. With impedance variance and S_{11} measurements

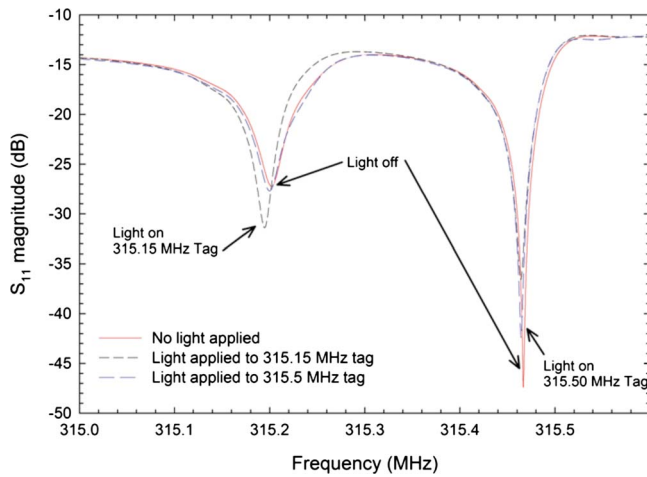

FIG. 10. (Color online) Incident S_{11} measurements at the network analyzer demonstrate that a pair of tags separated in operating frequency by 350 kHz is capable of individually sensing light vs dark conditions.

as the primary mode of data collection, the sensor platform is not limited to using photodiodes and the sensor element. Any sensor element that changes electrical impedance with sensor state is suitable for use on this passive sensor tag platform.

ACKNOWLEDGMENT

The work performed by Sandia National Laboratories is under the auspices of the U.S. Department of Energy, Contract No. DEAC04-94AL85000.

- ¹B. Warneke, B. Atwood, and K. S. J. Pister, Proceedings of the 14th IEEE International Conference on Micro Electro Mechanical Systems (MEMS 2001), 2001 (unpublished), pp. 357–360.
- ²A. Kansal, J. Hsu, S. Zahedi, and M. B. Srivastava, *Trans. Embedded Comput. Sys.* **6**, 32 (2007).
- ³U. Wolff, F. Schmidt, G. Scholl, and V. Magori, *Ultrasonics Symposium*, New York, NY, 1996 (unpublished), pp. 359–362.
- ⁴L. Reindl, G. Scholl, T. Ostertag, H. Scherr, U. Wolff, and F. Schmidt, *IEEE Trans. Ultrason. Ferroelectr. Freq. Control* **45**, 1281 (1998).
- ⁵A. Pohl, *IEEE Trans. Ultrason. Ferroelectr. Freq. Control* **47**, 317 (2000).
- ⁶A. Pohl and F. Seifert, *IEEE Proceedings of the Instrumentation and Measurement Technology Conference*, 1996 (unpublished), Vol. 2, pp. 1465–1468.
- ⁷A. Pohl, G. Ostermayer, L. Reindl, and F. Seifert, *IEEE Proceedings of the Ultrasonics Symposium*, 1997 (unpublished), Vol. 1, pp. 471–474.
- ⁸S. A. Stauth and B. A. Parviz, *Proc. Natl. Acad. Sci. U.S.A.* **103**, 13922 (2006).
- ⁹S. A. Stauth and B. A. Parviz, *Proceedings of the 2005 International Conference on MEMS, NANO and Smart Systems*, 2005 (unpublished), pp. 147–152.
- ¹⁰G. Scholl, C. Korden, E. Riha, C. C. W. Ruppel, U. Wolff, G. Riha, L. Reindl, and R. Weigel, *IEEE Microw. Mag.* **4**, 68 (2003).



Fabrication methods for creating flexible polymer substrate sensor tags

Harvey Ho and Jack L. Skinner

Citation: *J. Vac. Sci. Technol. B* **27**, 3104 (2009); doi: 10.1116/1.3258142

View online: <http://dx.doi.org/10.1116/1.3258142>

View Table of Contents: <http://avspublications.org/resource/1/JVTBD9/v27/i6>

Published by the AVS: Science & Technology of Materials, Interfaces, and Processing

Additional information on J. Vac. Sci. Technol. B

Journal Homepage: <http://avspublications.org/jvstb>

Journal Information: http://avspublications.org/jvstb/about/about_the_journal

Top downloads: http://avspublications.org/jvstb/top_20_most_downloaded

Information for Authors: http://avspublications.org/jvstb/authors/information_for_contributors